

Dec. 21, 1948.

R. L. TREUTHART

2,456,902

CONTACT AND SHORTING MECHANISM

Filed March 17, 1945

2 Sheets-Sheet 1

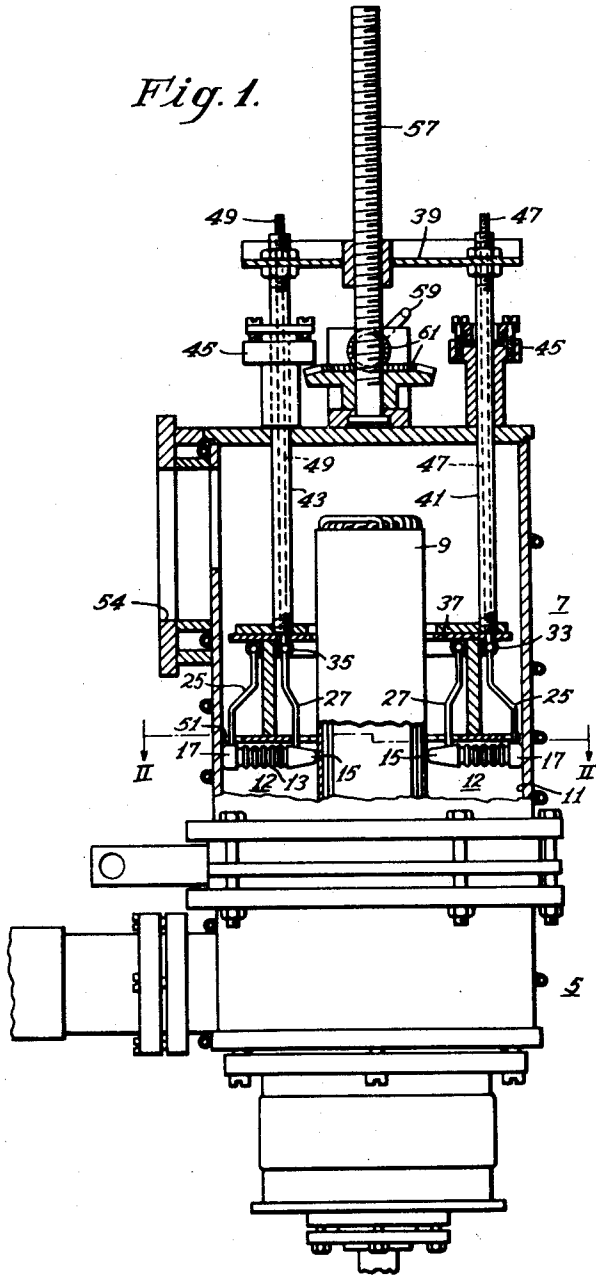

WITNESSES:

Edward Michalek

John A. Shipman

INVENTOR

Robert L. Treuthart.

BY

F. W. Lyle.
ATTORNEY

Dec. 21, 1948.

R. L. TREUTHART

2,456,902

CONTACT AND SHORTING MECHANISM

Filed March 17, 1945

2 Sheets-Sheet 2

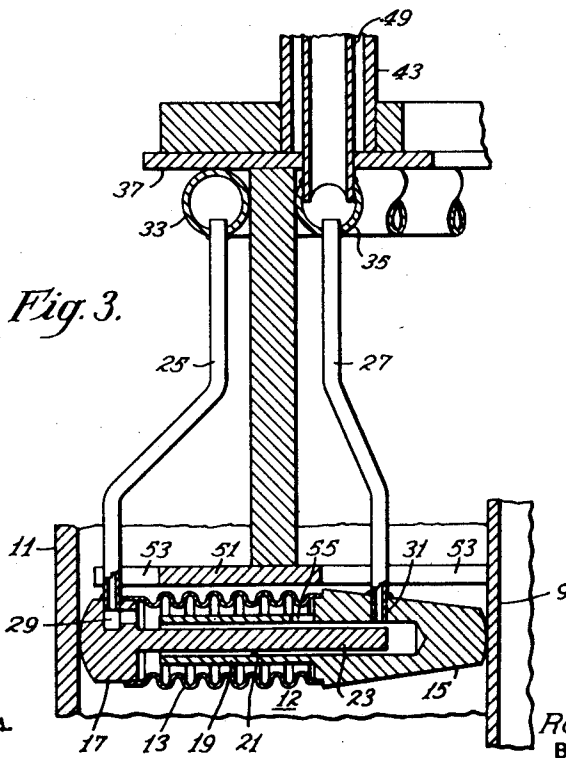
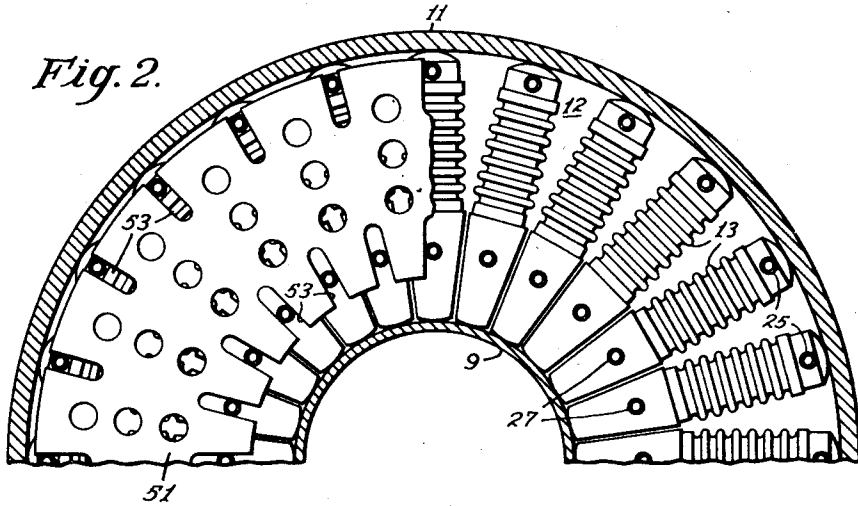

WITNESSES:

Edward Michaels

John P. Shipman

INVENTOR

Robert L. Treuthart.

BY

F. W. Lyle.
ATTORNEY

UNITED STATES PATENT OFFICE

2,456,902

CONTACT AND SHORTING MECHANISM

Robert L. Treuthart, Wilkinsburg, Pa., assignor
to Westinghouse Electric Corporation, East
Pittsburgh, Pa., a corporation of Pennsylvania

Application March 17, 1945, Serial No. 583,295

12 Claims. (Cl. 173—324)

1

This invention relates to contacts, and has particular relation to a sliding contactor for use in interconnecting two spaced surfaces of an electric circuit.

A contactor for use in establishing a short circuit between two points in an electrical circuit has heat developed therein by the flow of current therethrough. This heat is a source of considerable difficulty in many cases and particularly in ultra high-frequency electrical apparatus where the high frequency current often causes the contactor to be heated excessively. Consequently, some provisions must be made for cooling the contactor. This problem is rendered considerably more difficult when the contactor is to be of the sliding type having pressure engagement with the two spaced surfaces. There must then be provided some means to move the contactor. Moreover, as the two spaced surfaces are often irregular and may not be uniformly spaced throughout the active length thereof, the contactor must also be arranged to insure and maintain a pressure engagement with said surfaces forming an efficient electrical connection at all positions of the contactor.

It is an object of my invention to provide a novel pressure connection between two spaced surfaces.

Another object of my invention is to provide a new and improved slidable connection between two spaced surfaces.

A further object of my invention is to provide a new and improved slidable connection between two spaced surfaces which includes means for cooling the connector.

Still another object of my invention is to provide a novel sliding contactor for use in forming a conductive connection between two spaced surfaces of an electrical apparatus.

A still further object of my invention is to provide a new and improved sliding contactor for use in forming a conductive connection between two spaced surfaces of an electric circuit in which the contactor is arranged to conduct current and means are provided for cooling the contactor.

In accordance with my invention, I provide a contactor which comprises a hollow member such as a bellows structure which is expansible under internal pressure. The bellows structure has an inlet and an outlet adapted to be connected to a source of cooling fluid to effect a supply of the cooling fluid through the interior of the bellows structure under pressure to cool and expand it, the bellows structure being positioned

2

to expand toward the surfaces to insure pressure engagement therewith when the fluid is supplied therethrough. Means are provided to move the contactor with the fluid serving not only to insure and maintain engagement between the contactor and the surfaces but also to cool the contactor at the same time. Baffles may also be provided within the bellows structure to direct the cooling fluid adjacent to the portion of the structure which is subject to the greater heat.

The features of my invention which I consider novel are set forth with more particularity in the accompanying claims. The invention itself, however, with respect to details of construction and operation, together with additional advantages and objects thereof, may best be understood from the following description of a specific embodiment when read in connection with the accompanying drawings, in which:

Figure 1 illustrates a specific embodiment of my invention as applied to a cavity resonator which is part of an ultra-high-frequency electronic tube,

Fig. 2 is a partial view in cross section taken along line II—II of Fig. 1, and

Fig. 3 is a detail cross sectional view of the bellows structure and the cooling arrangement thereof.

An ultra-high-frequency electronic tube 5 is illustrated in Fig. 1 and includes a cavity resonator formed of a generally cylindrical metal body 7 having a coaxial, generally cylindrical reentrant protuberance 9. Those details of the tube which are not shown or described herein may be found in the copending application of David H. Sloan, Serial No. 583,257, filed on March 17, 1945.

For reasons set forth in the Sloan application, it is desirable to provide a plurality of sliding contactors forming an electrical connection between the side wall surface of the protuberance 9 and the surface of the outer side wall 11 of the resonator. In accordance with my invention, each of these contactors is formed by a bellows structure 12 as shown in Fig. 3. A flexible corrugated metal, cylindrically-shaped bellows 13 is provided, the ends of which may be moved relative to each other in a direction parallel to the axis of the bellows. A contact button 15 is secured to, within and closing one end of the bellows 13 while a second contact button 17 is secured to, within and closing the other end of the bellows 13. The first button 15 is provided with a projection 19 which extends axially into the interior of the bellows 13 and has an axial

bore 21 therein. The second button 17 is provided with an axial projection 23 which extends into the axial bore 21 in the other button 15. This arrangement provides a guide to prevent distortion of the bellows structure during expansion and contraction.

Each bellows structure 12 is supported by an inlet pipe 25 and an outlet pipe 27 for cooling fluid connected to an inlet passage 29 in button 17 and an outlet passage 31 in button 15, respectively. The inlet and outlet pipes 25 and 27 are, in turn, supported from circular manifolds 33 and 35, respectively, which are mounted on a ring-like plate 37 suspended from an adjustable arm 39 on the top of the tube by pipes 41 and 43 extending through vacuum-tight sliding seals 45 at the top of the body 7. The manifolds 33 and 35 have lead lines 47 and 49 extending upward through the supporting pipes 41 and 43, respectively. The lead-lines 47 and 49 are adapted to be connected to a source (not shown) of cooling fluid under pressure. A second ring-like plate 51 is suspended from and below the first plate 37 and has slots 53 therein through which the inlet and outlet pipes 25 and 27 extend, the slot serving to maintain the bellows structure 12 in its proper position.

A plurality of bellows structures 12 are arranged radially about the protuberance 9 with the contact buttons 15 against the side wall surface of the protuberance 9 and the contact button 17 against the surface of the outer side wall 11 of the resonator as shown in Fig. 3. The contact buttons 15 and 17 preferably have rounded ends to facilitate good contact, and the sides of buttons 15 are preferably tapered to permit a greater number of bellows structures to be positioned about the protuberance. The resonator is also provided with a flanged opening 54 therein to which a vacuum pump may be connected to evacuate the interior of the tube.

The cooling fluid used is preferably a liquid such as water. The path of the cooling fluid may be traced from the lead line 47 to the inlet manifold 33 and thence through the inlet pipe 25 of each of the bellows structures 12 to the inlet passage 29 of the corresponding bellows 13. The fluid then passes through the interior of the bellows structure 12 to the outlet passage 31 and through the outlet pipe 27 to the outlet manifold 35 from which the fluid is returned to the source through the second lead line 49. It is to be noted that the inlet passage 29 opens into the space between the bellows 13 and the axial projection 23 on contact button 17 while the outlet passage leads from the axial bore 21 in button 15. Fluid passing from the inlet passage 29 to the outlet passage may flow either through the space between the axial projection 23 on button 17 and the walls of the axial bore in button 15 and its projection 19 or through the space between the bellows 13 and the projection 19 of button 15 and an opening 55 in the projection to the axial bore 21. The spacings are arranged to cause most of the fluid to pass through the space adjacent the bellows 13 since the bellows 13 being relatively thin tends to be heated excessively by the current conducted therethrough and needs more fluid to carry away the heat. The pressure of the fluid within each of the bellows structures causes the structure to be expanded axially. The inlet and outlet pipes 25 and 27 are sufficiently flexible to permit movement of the contact buttons 15 and 17 to effect a good pressure contact between each button and the adjacent surface of either the pro-

tuberance 9 or the outer side wall 11 of the resonator, as the case may be.

To move the bellows structures up and down and thereby change the position of the connection or short-circuit between the protuberance 9 and the outer side wall 11 of the resonator, the arm 39 from which the supporting pipes 41 and 43 are suspended is threadedly engaged with a center shaft 57 mounted on the top of the tube. This shaft 57 may be rotated manually by means of a crank 59 and gears 61. As the shaft 57 is rotated, the threaded engagement between the shaft 57 and the arm 39 causes the arm 39 to be moved up or down depending upon the direction of rotation of the shaft 57. As a result, the bellows structures 12 are moved bodily up and down within the resonator, the contact buttons 15 and 17 sliding on the surfaces of the wall 11 and protuberance 9 respectively with the fluid pressure maintaining good contact between the buttons and the surfaces. Of course when the cooling fluid does not flow through the bellows structure, the natural resilience of the bellows 13 and the inlet and outlet pipes 25 and 27 causes the bellows structure to contract slightly and may even result in breaking the connection entirely.

While the sliding contactor as described is shown as forming a connection between two coaxial and generally cylindrical surfaces, it is obvious that it may be employed to form a connection between other spaced surfaces. For example, the bellows structure may be mounted inside a single pipe to connect diametrically opposite surfaces thereof, or it may be used as a sliding contactor between any other two spaced, regular or irregular surfaces facing each other and extending in the same general direction. In defining the surfaces as extending in the same general direction, it is not meant that they must be parallel. The surfaces may, of course, be slightly diverging or converging as long as the expansion of the contactor insures a good pressure engagement with the surfaces. Other applications will be obvious to those skilled in the art.

While I have shown and described a specific embodiment of my invention, I am aware that other embodiments may be made without departing from the spirit of the invention. I do not intend, therefore, to limit my invention to the specific embodiment shown and described.

I claim as my invention:

1. In combination with two spaced and facing surfaces of an electric circuit, an elongated hollow member expansible lengthwise and having an inlet and an outlet permitting a continuous supply of cooling fluid through the interior of said member under pressure to cool and expand it, said member being positioned lengthwise between said surfaces and forming when expanded an electrical interconnection therebetween for the conduction of current.

2. In combination with two spaced surfaces of an electrical circuit, a hollow, expansible, conductive member having an inlet and an outlet permitting cooling fluid under pressure to be supplied continuously through the interior of said member to cool and expand it, said member being positioned to expand toward said surfaces for pressure engagement therewith to form an electrical interconnection of said surfaces for the conduction of current therebetween.

3. In combination with two spaced surfaces of an electric circuit, a hollow, conductive, expansible bellows structure for interconnecting said surfaces to conduct current therebetween tending to

5

develop heat in said bellows structure, said bellows structure having an inlet and an outlet permitting cooling fluid under pressure to be supplied continuously through the bellows structure to cool and expand it and being positioned to expand toward said surfaces for pressure engagement therewith to form an efficient electrical inter-connection of said surfaces.

4. In combination with two spaced and facing surfaces of an electrical circuit, an elongated hollow member for interconnecting said two surfaces to conduct current therebetween tending to develop heat in said member, said member being expansible lengthwise and having an inlet and an outlet permitting cooling fluid under pressure to be supplied continuously through the interior of said member to cool and expand it, said member being positioned lengthwise between said surfaces to insure a pressure engagement between each of the ends thereof and the adjacent one of said surfaces forming an efficient electrical connection when the fluid is supplied therethrough.

5. In combination with two spaced surfaces of an electrical circuit, a hollow, expansible, conductive member for interconnecting said two surfaces to conduct current therebetween, the current causing heat to be developed in said member with one portion of said member tending to be heated excessively, said member having an inlet and an outlet to permit a supply of cooling fluid under pressure through the interior of said member to cool and expand it with said member being positioned for pressure engagement with said surfaces upon expansion, said member also having baffle means within it for directing the cooling fluid adjacent to said one portion.

6. In combination with two spaced and facing surfaces of an electric circuit, a bellows structure for interconnecting said surfaces to conduct current therebetween and including a generally cylindrical metallic bellows with a contact button closing each end thereof, the bellows structure being expansible axially and having an inlet near one end and an outlet near the other end to permit a supply of cooling fluid under pressure through the interior of said structure to cool and expand it, said structure being positioned axially between said surfaces to insure pressure engagement between each of the contact buttons and the adjacent one of said surfaces forming an efficient electrical connection when said fluid is supplied through the structure, the current through said structure tending to heat the wall of said bellows excessively, said structure including baffle means within said bellows between said inlet and outlet to direct the cooling fluid adjacent the wall of said bellows.

7. In combination with two spaced and facing surfaces, a bellows structure arranged for axial expansion and having an inlet near one end and an outlet near the other end, an inlet pipe and an outlet pipe connected to said inlet and outlet respectively and adapted to be connected to a source of cooling fluid to effect a supply thereof through the interior of said bellows structure under pressure to cool and expand it, said inlet and outlet pipes being sufficiently flexible to permit expansion of said bellows structure under the pressure of said cooling fluid, said structure being positioned axially between said surfaces to insure a pressure engagement between each end of said structure and the adjacent one of said surfaces when said fluid is supplied therethrough.

8. In combination with two spaced surfaces

6

extending in the same general direction, a hollow member expansible in a direction generally cross-wise of said general direction and having an end portion corresponding to each of said surfaces located for pressure engagement therewith upon expansion of said member, said member having an inlet and an outlet adapted to be connected to a source of fluid to effect a supply thereof under pressure through the interior of said member to expand it, and means connected to said member for moving it in said general direction to change the points of engagement between said end portions and said surfaces, the end portions being slidable on said surfaces while maintaining pressure engagement therewith during movement of said member.

9. In combination with two spaced surfaces of an electric circuit, said surfaces facing each other and extending in the same general direction, an elongated hollow conductive member positioned lengthwise between said surfaces and expansible lengthwise to provide a pressure engagement between the ends of the member and said surfaces, thereby interconnecting a point on one surface with a point on the other surface to conduct current therebetween, the current through said member tending to cause heat to be developed therein, said member having an inlet and an outlet to permit a supply of cooling fluid under pressure through the interior of said member to cool and expand it, and means connected to said member for moving it in said general direction to change the points of interconnection, the ends of said member being slidable on said surfaces while maintaining pressure engagement therewith during movement of said member.

10. In combination with two spaced surfaces of an electric circuit, said surfaces facing each other and extending in the same general direction, a bellows structure for interconnecting a point on one of said surfaces with a point on the other surface to conduct current therebetween, comprising a generally cylindrical, axially expansible bellows with a contact button closing each end thereof positioned axially between said surfaces so that upon expansion each contact button has a pressure engagement with the corresponding surface, said structure having an inlet and an outlet to permit a supply of cooling fluid under pressure through the interior of said structure to cool and expand it, and means connected to said structure for moving it in the same general direction in which said surfaces extend to change the points of interconnection, the contact buttons being slidable on said surfaces while maintaining pressure engagement therewith during movement of said structure.

11. In combination with two spaced and facing surfaces of an electrical circuit, a bellows structure arranged for axial expansion and having an inlet near one end and an outlet near the other end, an inlet pipe and an outlet pipe connected to said inlet and outlet respectively and adapted to be connected to a source of cooling fluid to effect a supply thereof through the interior of said bellows structure under pressure to cool and expand it, said inlet and outlet pipes being sufficiently flexible to permit expansion of said bellows structure under the pressure of said cooling fluid, said structure being positioned axially between said surfaces to insure a pressure engagement between each end of said structure and the adjacent one of said surfaces when said fluid is supplied therethrough.

12. In combination with two spaced surfaces

of an electrical circuit extending in the same general direction, a hollow member expansible in a direction generally crosswise of said general direction and having an end portion corresponding to each of said surfaces located for pressure engagement therewith upon expansion of said member, said member having an inlet and an outlet adapted to be connected to a source of fluid to effect a supply thereof under pressure through the interior of said member to expand it, and means connected to said member for moving it in said general direction to change the points of engagement between said end portions and said surfaces, the end portions being slidable on said surfaces while maintaining pressure engagement therewith during movement of said member.

ROBERT L. TREUTHART.

REFERENCES CITED

The following references are of record in the file of this patent:

UNITED STATES PATENTS

Number	Name	Date
1,137,362	Spalding -----	Apr. 27, 1915
1,543,654	Coolidge -----	June 23, 1925
1,874,478	Fayer -----	Aug. 30, 1932
2,163,959	Nilson -----	June 27, 1939
2,233,763	Ayer -----	Mar. 4, 1941
2,290,344	Martin -----	July 21, 1942