



- (51) International Patent Classification:  
*H04B 7/06* (2006.01)
- (21) International Application Number:  
PCT/EP2016/056634
- (22) International Filing Date:  
24 March 2016 (24.03.2016)
- (25) Filing Language: English
- (26) Publication Language: English
- (71) Applicant: TELEFONAKTIEBOLAGET LM ERICSSON (PUBL) [SE/SE]; SE-164 83 Stockholm (SE).
- (72) Inventors: ATHLEY, Fredrik; Banvallen 65A, SE-429 30 Kullavik (SE). PETERSSON, Sven; Rotevägen 1, SE-433 69 Sävedalen (SE).
- (74) Agent: ERICSSON; Patent Development, Torshamnsgatan 21-23, 164 80 Stockholm (SE).
- (81) Designated States (unless otherwise indicated, for every kind of national protection available): AE, AG, AL, AM, AO, AT, AU, AZ, BA, BB, BG, BH, BN, BR, BW, BY,

BZ, CA, CH, CL, CN, CO, CR, CU, CZ, DE, DK, DM, DO, DZ, EC, EE, EG, ES, FI, GB, GD, GE, GH, GM, GT, HN, HR, HU, ID, IL, IN, IR, IS, JP, KE, KG, KN, KP, KR, KZ, LA, LC, LK, LR, LS, LU, LY, MA, MD, ME, MG, MK, MN, MW, MX, MY, MZ, NA, NG, NI, NO, NZ, OM, PA, PE, PG, PH, PL, PT, QA, RO, RS, RU, RW, SA, SC, SD, SE, SG, SK, SL, SM, ST, SV, SY, TH, TJ, TM, TN, TR, TT, TZ, UA, UG, US, UZ, VC, VN, ZA, ZM, ZW.

- (84) Designated States (unless otherwise indicated, for every kind of regional protection available): ARIPO (BW, GH, GM, KE, LR, LS, MW, MZ, NA, RW, SD, SL, ST, SZ, TZ, UG, ZM, ZW), Eurasian (AM, AZ, BY, KG, KZ, RU, TJ, TM), European (AL, AT, BE, BG, CH, CY, CZ, DE, DK, EE, ES, FI, FR, GB, GR, HR, HU, IE, IS, IT, LT, LU, LV, MC, MK, MT, NL, NO, PL, PT, RO, RS, SE, SI, SK, SM, TR), OAPI (BF, BJ, CF, CG, CI, CM, GA, GN, GQ, GW, KM, ML, MR, NE, SN, TD, TG).

Published:  
— with international search report (Art. 21(3))

(54) Title: A WIRELESS COMMUNICATION NODE ADAPTED TO RADIATE ANTENNA BEAMS OF DIFFERENT TYPES

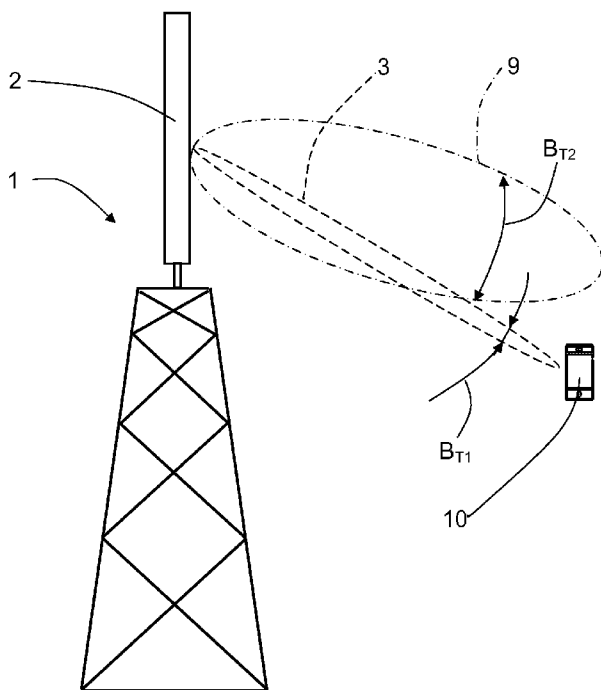

FIG. 1

(57) Abstract: The present disclosure relates to a wireless communication node (1) comprising an antenna arrangement (2) that is adapted to radiate at least one radiation beam (3, 4, 5; 6, 7, 8) of a first type and at least one radiation beam (9) of a second type. Said at least one radiation beam (3, 4, 5; 6, 7, 8) of the first type has a first type beamwidth (BT1) and said at least one radiation beam (9) of the second type has a second type beamwidth (BT2) that exceeds the first type beamwidth (BT1). Said at least one radiation beam (3, 4, 5; 6, 7, 8) of the first type is arranged for communication with at least a first other node (10, 11), and where said at least one radiation beam (9) of the second type is arranged for detection of changes in propagation paths for said other node (10, 11) and/or appearances of further other nodes.

WO 2017/162301 A1

## TITLE

A wireless communication node adapted to radiate antenna beams of different types

## TECHNICAL FIELD

- 5 The present disclosure relates to a wireless communication node comprising an antenna arrangement that is adapted to radiate at least one radiation beam of a first type and at least one radiation beam of a second type.

## BACKGROUND

- 10 Massive beamforming is regarded as an important technical component for 5G wireless communications. With massive beamforming, hundreds of antenna elements are arranged to be used at the base station (BS) as opposed to only a few antennas in previous systems.
- 15 Many beamforming concepts rely on the base station (BS) using a grid-of-beams (GoB) approach. One such approach is that the BS transmits reference signals in a number of beams, herein referred to as beam reference signals (BRS:s), in order to enable a user terminal, user equipment (UE), to measure which beam that is the best/most suitable. Such measurements could be based on, e.g., reference signal  
20 received power (RSRP). The UE then reports an index for the best beam, or indices to a number of the best beams to the BS. The RSRP for the corresponding beams could also be reported to the BS. Based on these reports, the BS can decide which beam or beams to use for the data transmission.
- 25 The GoB typically consists of a number of predetermined fixed beams with beamforming weights obtained from a, possibly oversampled, DFT (Discrete Fourier Transform) matrix. In order not to lose any information in the data collected by the antenna elements, the number of beams in the GoB should be at least as many as the number of antenna elements. This means that the number of beams in the GoB  
30 of a potential massive beamforming system at least could be several hundreds.

With many beams in the GoB, a high number of BRS:s may be required. This could lead to pilot contamination, high consumption of radio resource elements for the pilots, and comprehensive measurement procedures in the UE in order to estimate the best beam or beams to be used for data transmission.

5

One solution to this problem is to transmit BRSs only in a few beams in the GoB. If the directions to all active UE:s are known, the UE:s are not moving, and no new UE:s enter the system, this could be a viable approach. However, problems will occur if new UE:s enter the system and/or established propagation paths suddenly are obstructed due to, e.g., a UE moving behind a building. In such cases, the direction  
10 to the new UE or the new dominating propagation path cannot be estimated by means of BRSs if no BRSs are transmitted in those directions. This may lead to that active transmissions beams are lost and that new active transmission beams cannot be established for new UE:s.

15

There is thus a need for a wireless communication node that is arranged to handle abrupt changes in dominating propagation paths for existing UE:s and the appearance of new UE:s in a more efficient and reliable manner than previously known.

20

## SUMMARY

It is an object of the present disclosure to provide

25

Said object is obtained by means of a wireless communication node comprising an antenna arrangement that is adapted to radiate at least one radiation beam of a first type and at least one radiation beam of a second type. Said at least one radiation beam of the first type has a first type beamwidth and said at least one radiation beam of the second type has a second type beamwidth that exceeds the first type  
30 beamwidth. Said at least one radiation beam of the first type is arranged for communication with at least a first other node, and said at least one radiation beam of the second type is arranged for detection of changes in propagation paths for said other node and/or appearances of further other nodes.

Said object is also obtained by means of a method for antenna radiation beam control, comprising:

- Radiating at least one radiation beam of a first type.
- 5 – Radiating at least one radiation beam of a second type; wherein said at least one radiation beam of the first type has a first type beamwidth and said at least one radiation beam of the second type has a second type beamwidth that exceeds the first type beamwidth.

The method further comprises:

- 10 – Using said at least one radiation beam of the first type for communication with at least a first other node.
- Using said at least one radiation beam of the second type for detection of changes in propagation paths and/or appearances of further nodes.

15 A number of advantages are obtained by means of the present disclosure. Mainly, beam finding and tracking is enabled in a dynamic environment with abrupt changes in dominating propagation paths for existing nodes, such as UE:s, and appearance of new nodes, such as UE:s, using a reduced amount of pilots compared to previously known solutions.

20 According to an example, the antenna arrangement is adapted to change a radiation beam of the second type when an appearance of any other node has been detected by said radiation beam. This change comprises forming at least one radiation beam of the first type that is arranged for communication with said any other node.

25 According to another example, the change also comprises maintaining a radiation beam of the second type.

In this manner, the desired functionality is maintained.

30 According to another example, the change also comprises forming at least two radiation beams of the second type.

According to another example, two or more radiation beams of the first type are arranged for communication with each other node in order to enable beam-switching, and/or multi-layer or diversity transmission/reception.

- 5 According to another example, the node is arranged to activate a radiation beam of the second type for a region that has been deprived of radiation beams of the first type.

In this manner, the desired functionality is provided in an area where it is needed.

10

According to another example, the antenna arrangement comprises at least one antenna array of dual polarized antenna elements that are arranged for dual polarization beam-forming.

- 15 Generation of a GoB with beams having adjustable beamwidths with full PA utilization is enabled in the case of an active antenna array architecture based on dual polarization beam-forming (DPBF).

More examples are disclosed in the dependent claims.

20

#### BRIEF DESCRIPTION OF THE DRAWINGS

The present disclosure will now be described more in detail with reference to the appended drawings, where:

- 25 Figure 1 shows a side view of a wireless communication node;

Figure 2 shows a schematic view of a wireless communication node that communicates with UE:s where a new UE appears;

- 30 Figure 3 shows an alternative step for radiation beam change;

Figure 4 shows a completed radiation beam change;

- Figure 5 shows an alternative for radiation beam generation;
- Figure 6 shows an alternative for radiation beam generation when a UE has left;
- 5 Figure 7 shows another alternative for radiation beam generation;
- Figure 8 shows a schematic view of a wireless communication node that communicates with a UE;
- 10 Figure 9 shows a schematic view of detection of a new propagation path when the UE in Figure 8 is obscured;
- Figure 10 shows a schematic view of a generated new propagation path;
- 15 Figure 10 shows a schematic view of an antenna array of dual polarized antenna elements;
- Figure 12 shows a flowchart for a method according to the present disclosure; and
- 20 Figure 13 illustrates a wireless communication node arrangement according to some aspects of the present disclosure.

#### DETAILED DESCRIPTION

With reference to Figure 1 and Figure 2, there is a wireless communication node 1  
25 comprising an antenna arrangement 2 that is adapted to radiate six radiation beams 3, 4, 5; 6, 7, 8 of a first type and one radiation beam 9 of a second type. A first set of three radiation beams 3, 4, 5 are arranged for communication with a first user terminal, user equipment (UE) 10, and a second set of three radiation beams 6, 7, 8 are arranged for communication with a second UE 11.

30

According to the present disclosure, the radiation beams 3, 4, 5; 6, 7, 8 of the first type has a first type beamwidth  $B_{T1}$  and each one of the radiation beam 9 of the second type has a second type beamwidth  $B_{T2}$  that exceeds the first type beamwidth

5  $B_{T1}$ . The radiation beams 3, 4, 5; 6, 7, 8 of the first type are relatively narrow and arranged for communication with the UE:s 10, 11, constituting active radiation beams. A reason for having more than one active beam per UE is to enable beam switching when the UE moves. They can also be used for multi-layer or diversity transmission/reception if the channel conditions are suitable for that. Note that all active beams need not transmit or receive data. An active UE 10, 11 measures RSRP for these beams 3, 4, 5; 6, 7, 8 in order to enable a beam switch if another beam becomes more favorable.

10 The radiation beam 9 of the second type is constituted by a monitoring beam that has a relatively wide beamwidth and is arranged for detection of changes in propagation paths for the UE:s 10, 11 and/or appearances of further other UE:s, in Figure 2 indicated by the appearance of a third UE 12. As indicated in Figure 2, there are thus three narrow beams 3, 4, 5; 6, 7, 8 per UE 10, 11 that illustrate the active beams  
15 where beam reference signals (BRS:s) are transmitted. These can be used to track small movements of the UE:s 10, 11 which could lead to a change of best serving beam.

When the third UE 12 that requests establishment of data communication it is  
20 detected by the radiation beam 9 of the second type, constituting a monitoring beam, since there are now other beams in this area. The third UE 12 can now detect the BRS in the monitoring beam 9 and report reference signal received power (RSRP) to the communication node 1.

25 According to some aspects, the antenna arrangement 2 is adapted to change the radiation beam 9 of the second type. In this example, as shown in Figure 4, the change comprises forming three radiation beams 16, 17, 18 of the first type that are arranged for communication with the third UE 12. These radiation beams 16, 17, 18 of the first type are used for subsequent data transmission and beam tracking.

30 This change is according to some aspects performed in steps, as shown also with reference to Figure 3. Here, the change first comprises forming a plurality of radiation beams 13, 14, 15 having a first beamwidth  $B_1$  in order to obtain first direction

information for the third UE 12, and then forming the three radiation beams 16, 17, 18 of the first type having a second beamwidth  $B_2$  as shown in Figure 2 in order to obtain second direction information for the third UE 12. The first beamwidth  $B_1$  falls below the beamwidth  $B_{T2}$  of the radiation beam 9 of the second type, and the second beamwidth  $B_2$  falls below the first beamwidth  $B_1$ . The accuracy of the second direction information exceeds the accuracy of the first direction information.

To maintain full coverage of BRS:s, two different examples for having additional wide monitoring beams will be described.

10

As shown in Figure 5 and Figure 6, two radiation beams 20, 21; 22, 23 of the second type, i.e. two monitoring beams that do not overlap with the active beams, are formed. The two monitoring beams that 20, 21 in Figure 5 are not as wide as the two monitoring beams that 22, 23 in Figure 6.

15

As shown in Figure 7, only one wide beam 19 of the second type is used instead.

In the following a further example will be presented with reference to the Figures 8-10.

20

With reference to Figure 8, there is an established data communication between the communication node 1 and a UE 28 using three narrow active beams 24, 25, 26 of the first type, and there is one wide monitoring beam 27 of the second type. Furthermore, there are two buildings, a first building 39 and a second building 40. As shown in Figure 8, the UE 28 is not obstructed by any of the buildings 39, 40, and data transmission can be performed using the three active beams 24, 25, 26.

25

As shown in Figure 9, the UE 28 moves such that the first building 39 obstructs the UE 28 from the active beams 24, 25, 26. It is here apparent that a reflection path 41 via the second building 40 can be utilized for the data transmission. This auxiliary propagation path 41 is detected by the UE 28 thanks to the BRS transmitted in the wide monitoring beam 27.

30

As shown in Figure 10, data transmission is now performed by using three new narrow active beams 29, 30, 31 of the first type utilizing the reflection path 41 in building B has been established while the previous active beams 24, 25, 26 have been released and replaced by a new wide monitoring beam 42 of the second type.

5 Generally, the communication node 1 is thus arranged to activate a radiation beam 42 of the second type for a region that has been deprived of radiation beams of the first type 24, 25, 26.

10 Generating a GoB (Grid of Beams) with beams having adjustable beamwidths is according to an aspect enabled by means of an antenna arrangement 2 of the communication node 1 that is constituted by an active antenna array architecture based on dual polarization beam-forming (DPBF). With reference to Figure 11, the antenna arrangement 2 of the communication node 1 comprises at least one active two-dimensional antenna array 32 of dual polarized antenna elements 33, 34 that are  
15 arranged for dual polarization beam-forming.

According to an aspect, each element and polarization has its own power amplifier (PA); this architecture enables adjustable beamwidths while maintaining full (PA) utilization in the active antenna array 32.

20

A method and active antenna array architecture is therefore according to an aspect based on DPBF for beam finding and tracking in a massive beamforming system using GoB. Narrow active beams track UE:s with established data communication, while simultaneously having wide monitoring beams to detect changes in dominating  
25 propagation paths or the appearance of new UE:s. The mix of narrow and wide beams in the GoB is achieved with full PA utilization when using a DPBF active antenna array architecture.

30 The beam finding and tracking is able to handle abrupt changes in dominating propagation paths for existing UE:s and the appearance of new UE:s, and is according to some aspects based on generating a GoB where the different beams being of different types that have different beamwidths that are adapted to the current situation. The GoB consists of a simultaneous mix of narrow beams of the first type

to cater for data transmission to active UE:s and wide beams of the second type to be able to discover new UE:s, as in the examples described with reference to Figure 2-7, or new propagation paths to already active UE:s, as in the example described with reference to Figure 8-10. According to an aspect, the narrow beams and the  
5 wide beams together give a complete coverage over an entire sector.

The first type beamwidth  $B_{T1}$  is not intended to be regarded as a certain value, but as a beamwidth span since all the radiation beam 3, 4, 5; 6, 7, 8 of the first type do not necessarily have to have identical beamwidths and beam-shapes, but where these  
10 may differ with a certain span, where this span is defined by the first type beamwidth  $B_{T1}$ . The same reasoning is valid for the second type beamwidth  $B_{T2}$ , the first beamwidth  $B_1$  and the second beamwidth  $B_2$ . Most importantly the first type beamwidth  $B_{T1}$  is relatively narrow and the second type beamwidth  $B_{T2}$  is relatively wide such that the disclosed beam finding and tracking is enabled as described  
15 above.

In this context, according to some aspects and only as an example, a relatively wide beamwidth has a half-power beamwidth that at least is twice as wide as the half-power beamwidth of a relatively narrow beamwidth  
20

The present disclosure is not limited to the examples above, but may vary within the scope of the appended claims. For example, it is not necessary that massive beamforming such as GoB is used; any type of beamforming that enables the disclosed beam finding and tracking is conceivable.  
25

The number of radiation beams of the first type and the number of radiation beams of the second type may vary. Generally, there is at least one radiation beam of the first type and at least one radiation beam of the second type.

30 It is not necessary that the antenna arrangement 2 is adapted to radiate more than one active beam per UE, but it is also conceivable that the antenna arrangement 2 is adapted to radiate two active beams per UE or more. As understood from the

examples, the antenna arrangement 2 is furthermore adapted to radiate at least one radiation beam 9 of the second type.

5 It is not necessary that a new radiation beam of the second type is generated after a change where an initial radiation beam of the second type has been changed to one or more radiation beams of the first type, due to for example new UE:s that are discovered, or new propagation paths to already active UE:s. According to some aspects, possible generation of new radiation beam of the second type depends on other already existing radiation beams of the second type, sector layout, antenna  
10 arrangement capacity etc.

The UE:s are generally constituted by any types of suitable nodes such as for example any type of user terminals.

15 The antenna array can be one-dimensional as well as two-dimensional.

Generally, the present disclosure relates to a wireless communication node 1 comprising an antenna arrangement 2 that is adapted to radiate at least one radiation beam 3, 4, 5; 6, 7, 8 of a first type and at least one radiation beam 9 of a second  
20 type. Said at least one radiation beam 3, 4, 5; 6, 7, 8 of the first type has a first type beamwidth  $B_{T1}$  and said at least one radiation beam 9 of the second type has a second type beamwidth  $B_{T2}$  that exceeds the first type beamwidth  $B_{T1}$ , where said at least one radiation beam 3, 4, 5; 6, 7, 8 of the first type is arranged for communication with at least a first other node 10, 11, and where said at least one  
25 radiation beam 9 of the second type is arranged for detection of changes in propagation paths for said other node 10, 11 and/or appearances of further other nodes.

According to an example, the antenna arrangement 2 is adapted to change a  
30 radiation beam 9 of the second type when an appearance of any other node 12 has been detected by said radiation beam 9, where the change comprises forming at least one radiation beam 13, 14, 15 of the first type that is arranged for communication with said any other node 12.

According to an example, the change first comprises forming a plurality of radiation beams 13, 14, 15 having a first beamwidth  $B_1$  in order to obtain first direction information for said any other node, and then forming a plurality of radiation beams 5 16, 17, 18 having a second beamwidth  $B_2$  in order to obtain second direction information for said any other node 12, where the first beamwidth  $B_1$  falls below the second type beamwidth  $B_{T2}$ , where the second beamwidth  $B_2$  falls below the first beamwidth  $B_1$ , and where the accuracy of the second direction information exceeds the accuracy of the first direction information.

10

According to an example, the radiation beams 16, 17, 18 having a second beamwidth  $B_2$  are constituted by radiation beams of the first type.

According to an example, the change also comprises maintaining a radiation beam 15 19 of the second type.

According to an example, the change also comprises forming at least two radiation beams 20, 21; 22, 23 of the second type.

20 According to an example, two or more radiation beams 3, 4, 5; 6, 7, 8; 16, 17, 18; 24, 25, 26; 29, 30, 31 of the first type are arranged for communication with each other node 10, 11, 12; 28 in order to enable beam-switching, and/or multi-layer or diversity transmission/reception.

25 According to an example, wherein the node 1 is arranged to activate and/or deactivate one or more radiation beams 6, 7, 8; 16, 17, 18; 24, 25, 26; 29, 30, 31 of the first type in dependence of measured communication properties.

30 According to an example, the node 1 is arranged to activate a radiation beam 23 of the second type for a region that has been deprived of radiation beams of the first type 6, 7, 8.

According to an example, the antenna arrangement 2 comprises at least one antenna array 32 of dual polarized antenna elements 33, 34 that are arranged for dual polarization beam-forming.

- 5 Generally, the present disclosure also relates to a method for antenna radiation beam control comprising:
- 35: radiating at least one radiation beam 3, 4, 5; 6, 7, 8 of a first type; and
  - 36: radiating at least one radiation beam 9 of a second type; wherein said at least one radiation beam 3, 4, 5; 6, 7, 8 of the first type has a first type beamwidth  $B_{T1}$  and
  - 10 said at least one radiation beam 9 of the second type has a second type beamwidth  $B_{T2}$  that exceeds the first type beamwidth  $B_{T1}$ , where the method further comprises:
    - 37: using said at least one radiation beam 3, 4, 5; 6, 7, 8 of the first type for communication with at least a first other node 10; and
    - 38: using said at least one radiation beam 9 of the second type for detection of
    - 15 changes in propagation paths and/or appearances of further nodes 11, 12.

According to an example, the method further comprises changing a radiation beam 9 of the second type when an appearance of any other node 12 has been detected by said radiation beam 9, where the change comprises forming at least one radiation

20 beam 13, 14, 15 of the first type that is used for communication with said any other node 12.

According to an example, the change first comprises forming a first plurality of radiation beams 13, 14, 15 having a first beamwidth  $B_1$  in order to obtain first

25 direction information for said any other node, and then forming a plurality of radiation beams 16, 17, 18 having a second beamwidth  $B_2$  in order to obtain second direction information for said any other node 12, where the first beamwidth  $B_1$  falls below the beamwidth  $B_{T2}$  of the radiation beam 4 of the second type, where the second beamwidth  $B_2$  falls below the first beamwidth  $B_1$ , and where the accuracy of the

30 second direction information exceeds the accuracy of the first direction information.

According to an example, the radiation beams 16, 17, 18 having a second beamwidth  $B_2$  are constituted by radiation beams of the first type.

According to an example, the change also comprises maintaining a radiation beam 19 of the second type.

- 5 According to an example, the change also comprises forming at least two radiation beams 20, 21; 22, 23 of the second type.

According to an example, the method comprises using two or more radiation beams 3, 4, 5; 6, 7, 8; 16, 17, 18; 24, 25, 26; 29, 30, 31 of the first type for communication  
10 with each other node 10, 11, 12; 28, enabling beam-switching, and/or multi-layer or diversity transmission/reception.

According to an example, the method comprises activating and/or de-activating one or more radiation beams 6, 7, 8; 16, 17, 18; 24, 25, 26; 29, 30, 31 of the first type in  
15 dependence of measured communication properties.

According to an example, the method comprises activating a radiation beam 23 of the second type for a region that has been deprived of radiation beams 6, 7, 8 of the first type.  
20

According to an example, the two types of radiation beams are obtained by using dual polarized beam-forming for at least one antenna array 32 of dual polarized antenna elements 33, 34.

25 Figure 13 shows a wireless communication node arrangement for antenna radiation beam control. The wireless communication node arrangement comprises:

- A first radiating module X35 configured to radiate at least one radiation beam 3, 4, 5; 6, 7, 8 of a first type.
- A second radiating module X36 configured to radiate at least one radiation  
30 beam 9 of a second type, where said at least one radiation beam 3, 4, 5; 6, 7, 8 of the first type has a first type beamwidth  $B_{T1}$  and said at least one radiation beam 9 of the second type has a second type beamwidth  $B_{T2}$  that exceeds the first type beamwidth  $B_{T1}$ .

- A communication module X37 configured to use said at least one radiation beam 3, 4, 5; 6, 7, 8 of the first type for communication with at least a first other node 10.
  - A detecting module X38 configured to use said at least one radiation beam (9) of the second type for detection of changes in propagation paths and/or appearances of further nodes (11, 12).
- 5

## CLAIMS

1. A wireless communication node (1) comprising an antenna arrangement (2) that is adapted to radiate at least one radiation beam (3, 4, 5; 6, 7, 8) of a first type and at least one radiation beam (9) of a second type, wherein said at least one radiation beam (3, 4, 5; 6, 7, 8) of the first type has a first type beamwidth ( $B_{T1}$ ) and said at least one radiation beam (9) of the second type has a second type beamwidth ( $B_{T2}$ ) that exceeds the first type beamwidth ( $B_{T1}$ ), where said at least one radiation beam (3, 4, 5; 6, 7, 8) of the first type is arranged for communication with at least a first other node (10, 11), and where said at least one radiation beam (9) of the second type is arranged for detection of changes in propagation paths for said other node (10, 11) and/or appearances of further other nodes.
2. The wireless communication node (1) according to claim 1, wherein the antenna arrangement (2) is adapted to change a radiation beam (9) of the second type when an appearance of any other node (12) has been detected by said radiation beam (9), where the change comprises forming at least one radiation beam (13, 14, 15) of the first type that is arranged for communication with said any other node (12).
3. The wireless communication node according to claim 2, wherein the change first comprises forming a plurality of radiation beams (13, 14, 15) having a first beamwidth ( $B_1$ ) in order to obtain first direction information for said any other node, and then forming a plurality of radiation beams (16, 17, 18) having a second beamwidth ( $B_2$ ) in order to obtain second direction information for said any other node (12), where the first beamwidth ( $B_1$ ) falls below the second type beamwidth ( $B_{T2}$ ), where the second beamwidth ( $B_2$ ) falls below the first beamwidth ( $B_1$ ), and where the accuracy of the second direction information exceeds the accuracy of the first direction information.
4. The wireless communication node according to claim 3, wherein the radiation beams (16, 17, 18) having a second beamwidth ( $B_2$ ) are constituted by radiation beams of the first type.

5. The wireless communication node (1) according to any one of the claims 2-4, wherein the change also comprises maintaining a radiation beam (19) of the second type.
- 5 6. The wireless communication node according to any one of the claims 2-4, wherein the change also comprises forming at least two radiation beams (20, 21; 22, 23) of the second type.
7. The wireless communication node according to any one of the previous  
10 claims, wherein two or more radiation beams (3, 4, 5; 6, 7, 8; 16, 17, 18; 24, 25, 26; 29, 30, 31) of the first type are arranged for communication with each other node (10, 11, 12; 28) in order to enable beam-switching, and/or multi-layer or diversity transmission/reception.
- 15 8. The wireless communication node according to claim 7, wherein the node (1) is arranged to activate and/or de-activate one or more radiation beams (6, 7, 8; 16, 17, 18; 24, 25, 26; 29, 30, 31) of the first type in dependence of measured communication properties.
- 20 9. The wireless communication node according to claim 8, wherein the node (1) is arranged to activate a radiation beam (23) of the second type for a region that has been deprived of radiation beams of the first type (6, 7, 8).
10. The wireless communication node according to any one of the previous  
25 claims, wherein the antenna arrangement (2) comprises at least one antenna array (32) of dual polarized antenna elements (33, 34) that are arranged for dual polarization beam-forming.
11. Method for antenna radiation beam control comprising:  
30 (35) radiating at least one radiation beam (3, 4, 5; 6, 7, 8) of a first type;  
and  
(36) radiating at least one radiation beam (9) of a second type; wherein said at least one radiation beam (3, 4, 5; 6, 7, 8) of the first type has a first type

beamwidth ( $B_{T1}$ ) and said at least one radiation beam (9) of the second type has a second type beamwidth ( $B_{T2}$ ) that exceeds the first type beamwidth ( $B_{T1}$ ), where the method further comprises:

5 (37) using said at least one radiation beam (3, 4, 5; 6, 7, 8) of the first type for communication with at least a first other node (10); and

(38) using said at least one radiation beam (9) of the second type for detection of changes in propagation paths and/or appearances of further nodes (11, 12).

10 12. The method according to claim 11, wherein the method further comprises changing a radiation beam (9) of the second type when an appearance of any other node (12) has been detected by said radiation beam (9), where the change comprises forming at least one radiation beam (13, 14, 15) of the first type that is used for communication with said any other node (12).

15 13. The method according to claim 12, wherein the change first comprises forming a first plurality of radiation beams (13, 14, 15) having a first beamwidth ( $B_1$ ) in order to obtain first direction information for said any other node, and then forming a plurality of radiation beams (16, 17, 18) having a second beamwidth ( $B_2$ ) in order to  
20 obtain second direction information for said any other node (12), where the first beamwidth ( $B_1$ ) falls below the beamwidth ( $B_{T2}$ ) of the radiation beam (4) of the second type, where the second beamwidth ( $B_2$ ) falls below the first beamwidth ( $B_1$ ), and where the accuracy of the second direction information exceeds the accuracy of the first direction information.

25 14. The method according to claim 13, wherein the radiation beams (16, 17, 18) having a second beamwidth ( $B_2$ ) are constituted by radiation beams of the first type.

30 15. The method according to any one of the claims 12-14, wherein the change also comprises maintaining a radiation beam (19) of the second type.

16. The method according to any one of the claims 12-14, wherein the change also comprises forming at least two radiation beams (20, 21; 22, 23) of the second type.

5 17. The method according to any one of the claims 11-16, wherein the method comprises using two or more radiation beams (3, 4, 5; 6, 7, 8; 16, 17, 18; 24, 25, 26; 29, 30, 31) of the first type for communication with each other node (10, 11, 12; 28), enabling beam-switching, and/or multi-layer or diversity transmission/reception.

10

18. The method according to claim 17, wherein the method comprises activating and/or de-activating one or more radiation beams (6, 7, 8; 16, 17, 18; 24, 25, 26; 29, 30, 31) of the first type in dependence of measured communication properties.

15

19. The method according to claim 18, wherein the method comprises activating a radiation beam (23) of the second type for a region that has been deprived of radiation beams (6, 7, 8) of the first type.

20 20. The method according to any one of the claims 11-19, wherein the two types of radiation beams are obtained by using dual polarized beam-forming for at least one antenna array (32) of dual polarized antenna elements (33, 34).

25

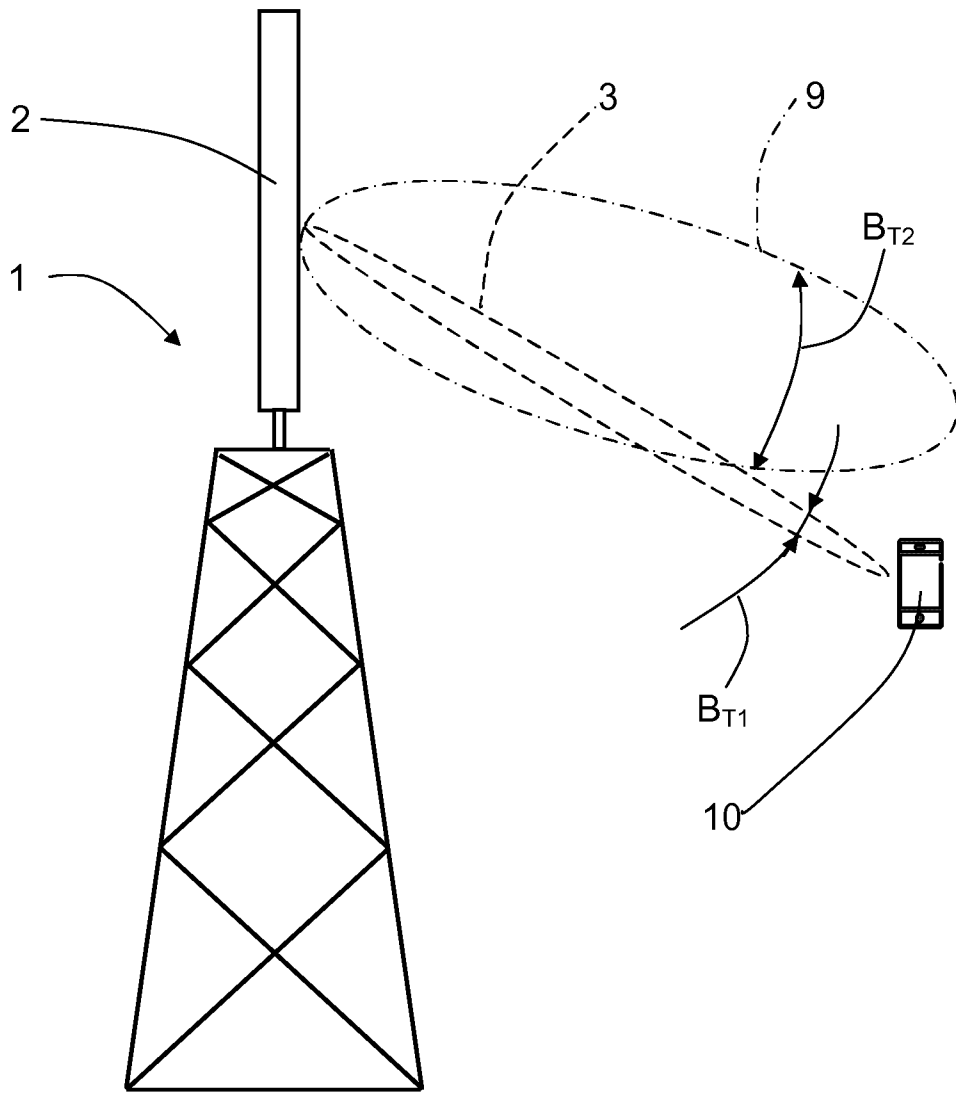

FIG. 1

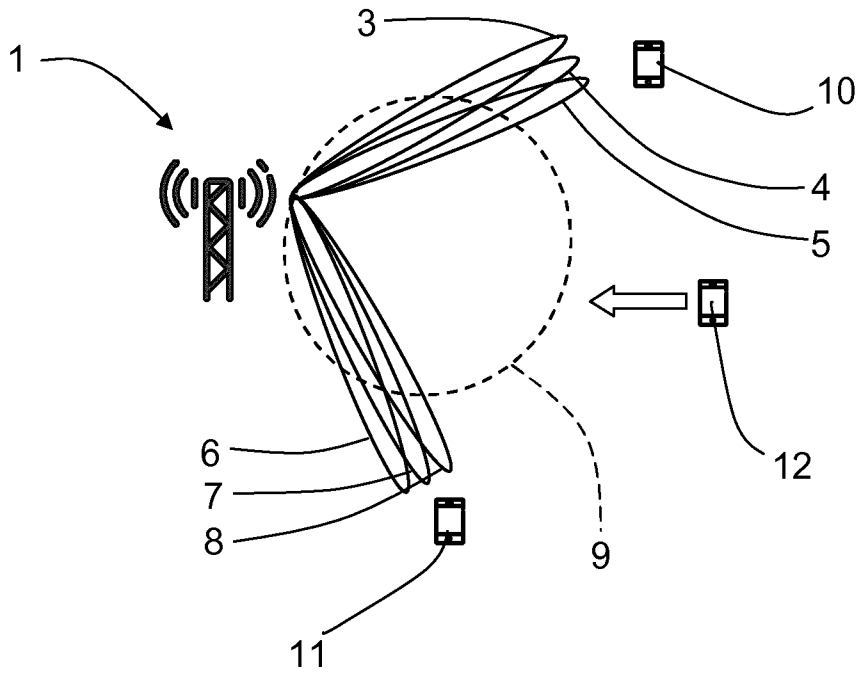

FIG. 2

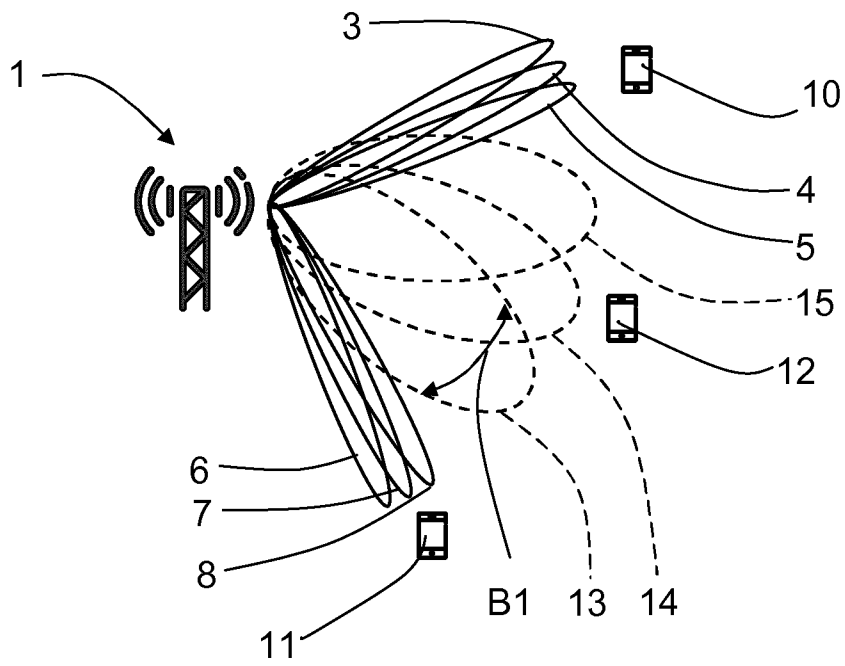

FIG. 3

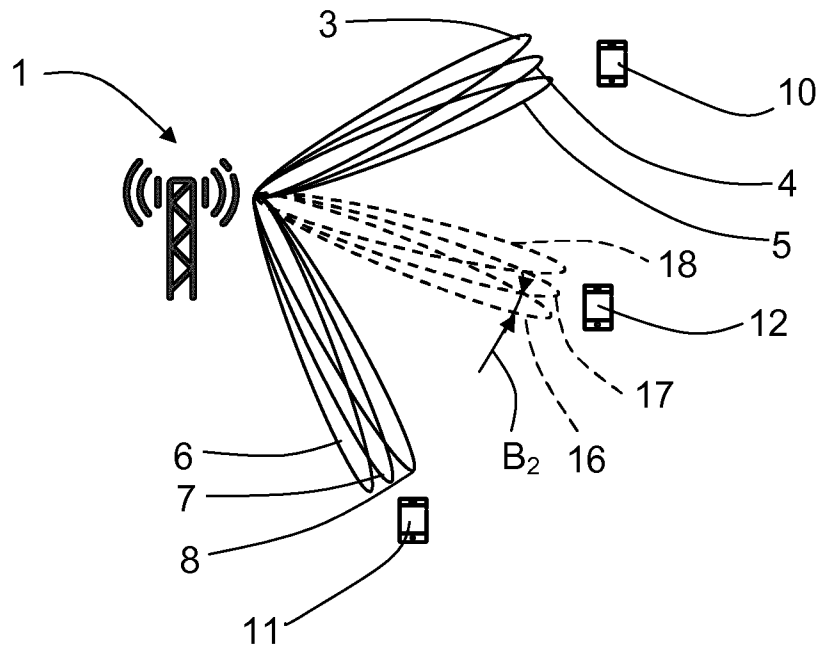

FIG. 4

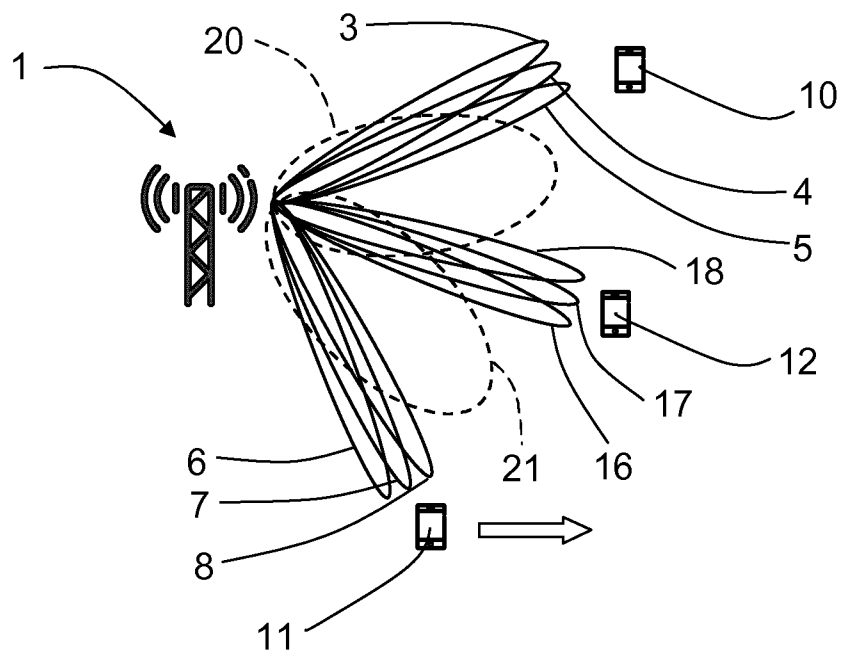

FIG. 5

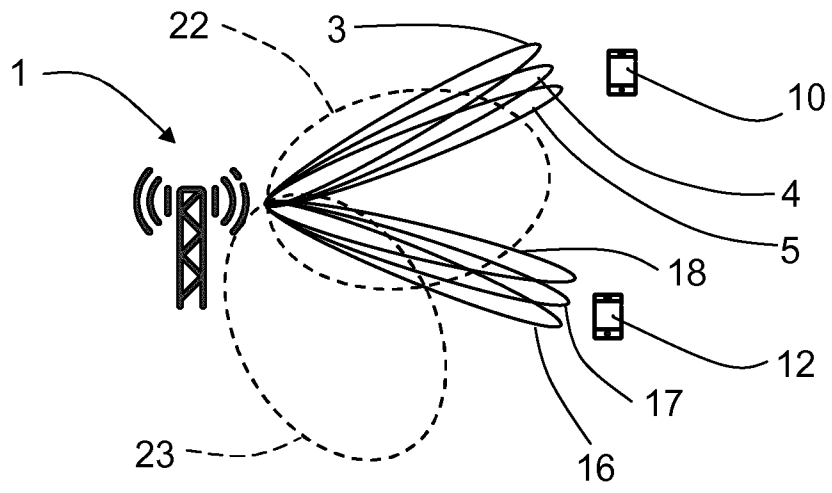

FIG. 6

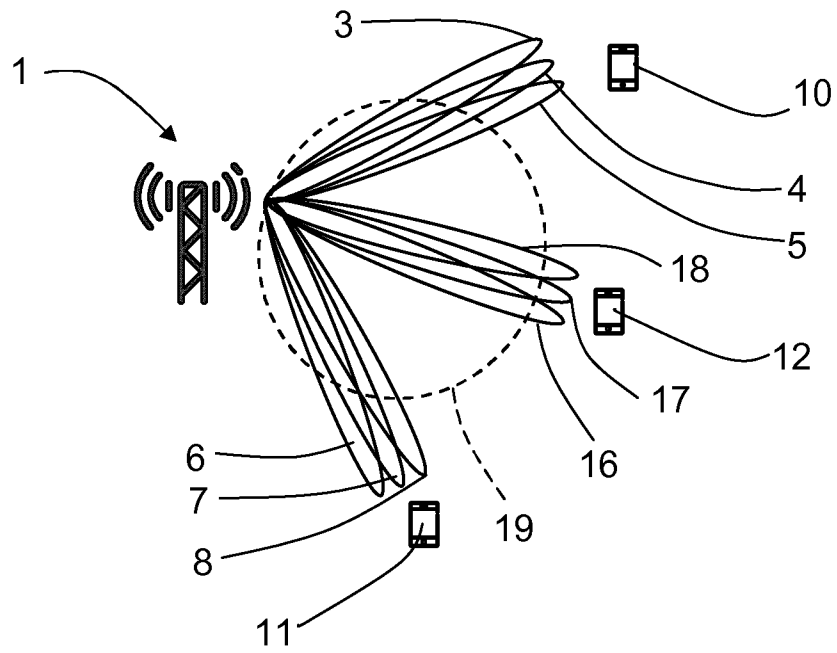

FIG. 7

5/8

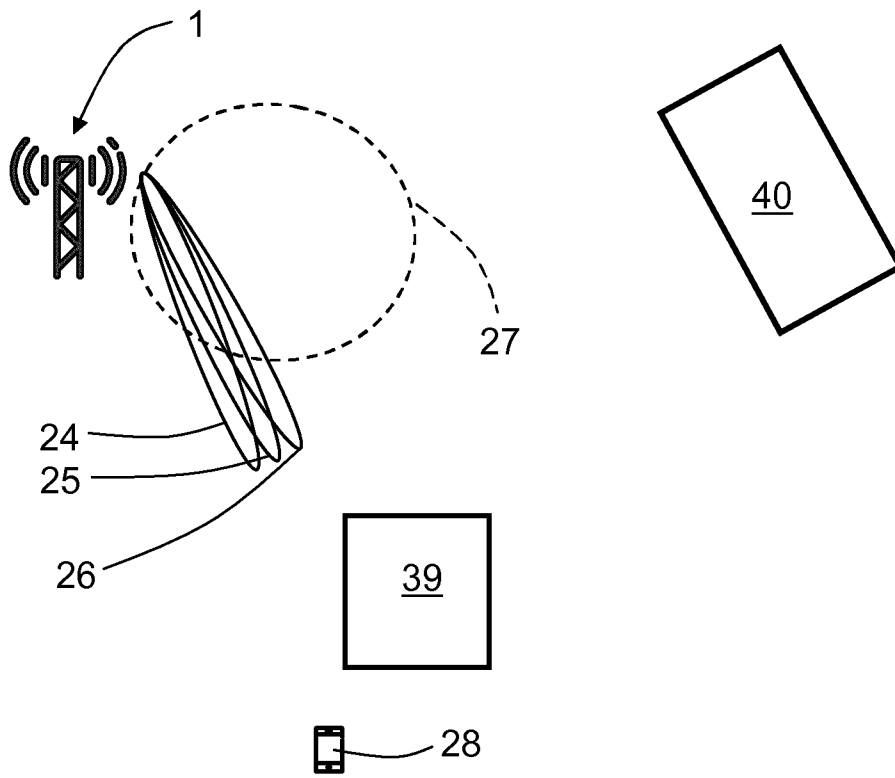

FIG. 8

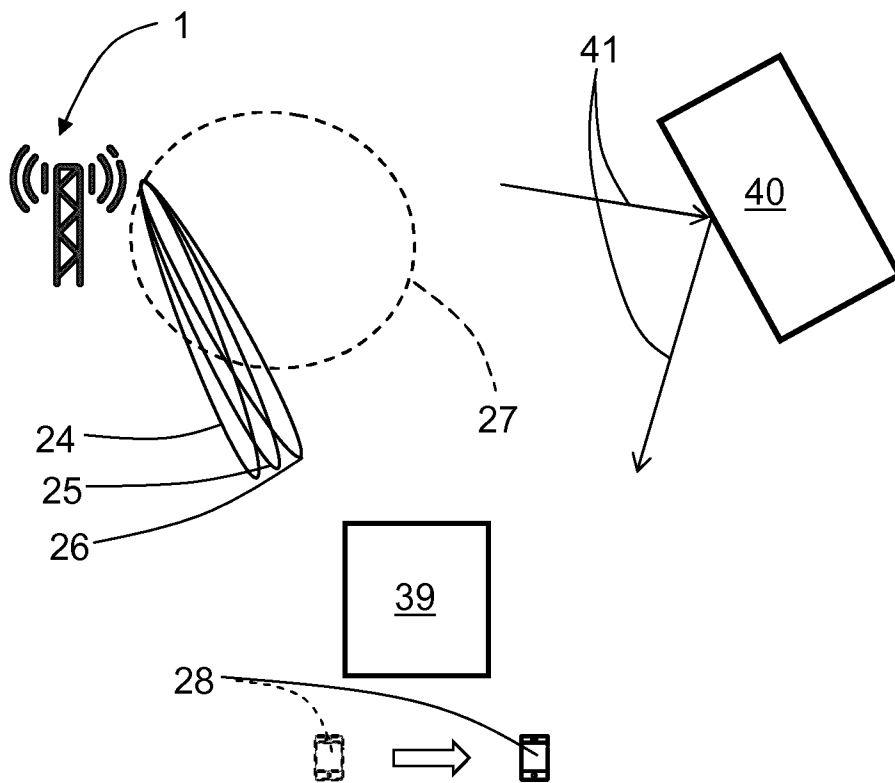

FIG. 9

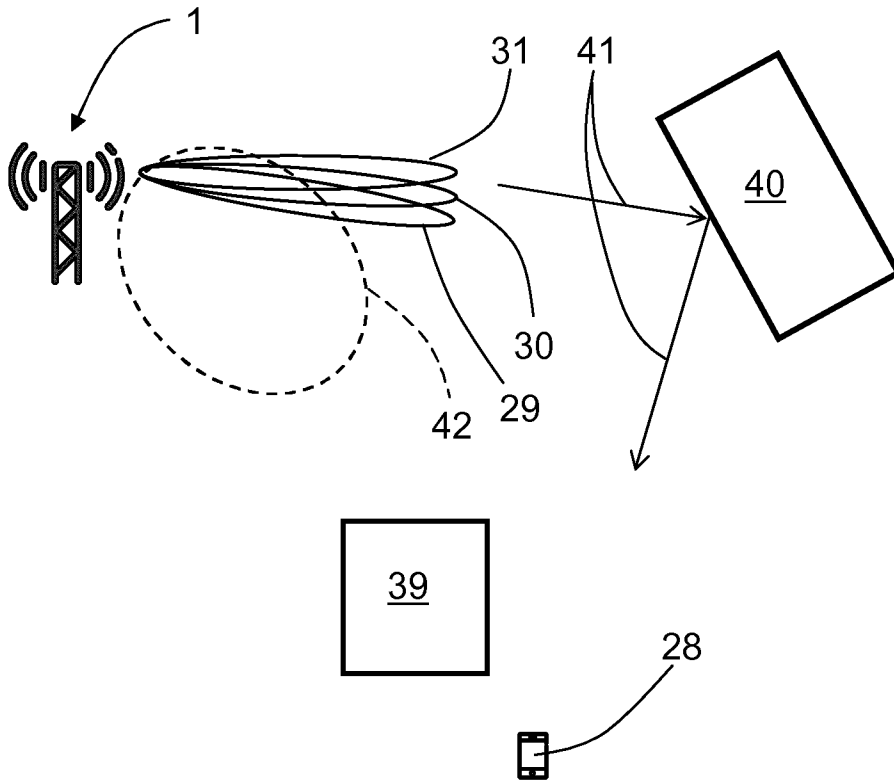

FIG. 10

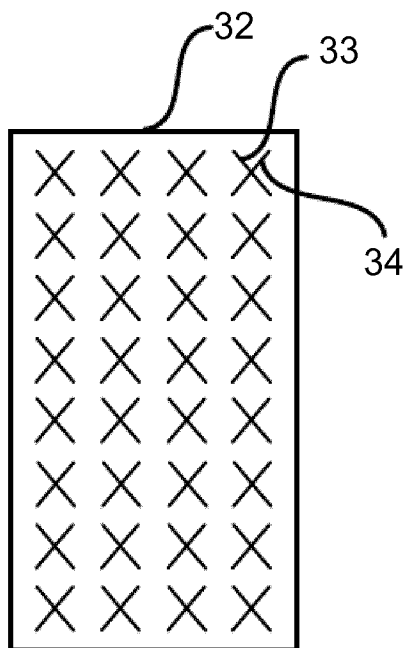

FIG. 11

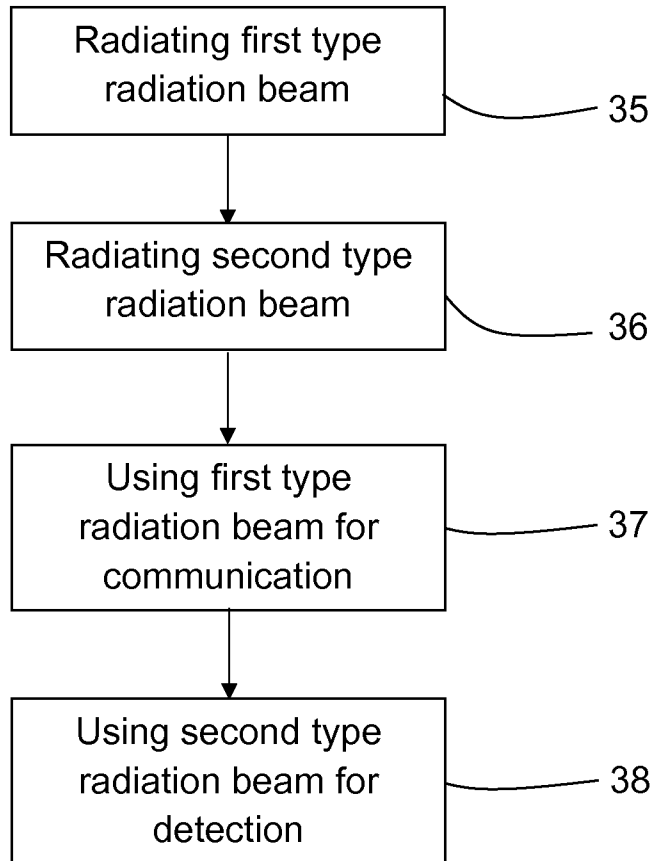

FIG. 12

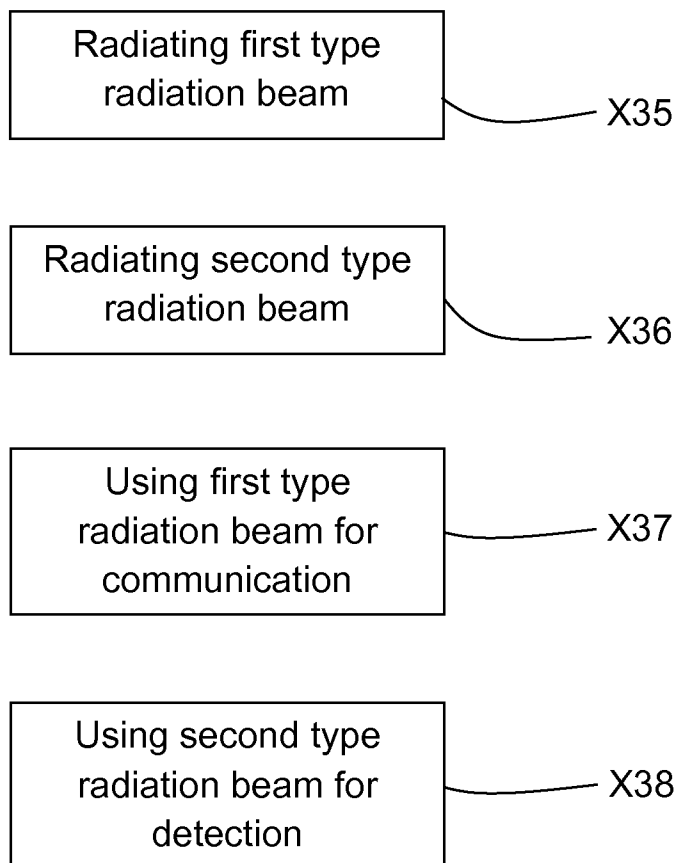

FIG. 13

**INTERNATIONAL SEARCH REPORT**

International application No  
PCT/EP2016/056634

**A. CLASSIFICATION OF SUBJECT MATTER**  
INV. H04B7/06  
ADD.

According to International Patent Classification (IPC) or to both national classification and IPC

**B. FIELDS SEARCHED**

Minimum documentation searched (classification system followed by classification symbols)  
H01Q H04W H04B

Documentation searched other than minimum documentation to the extent that such documents are included in the fields searched

Electronic data base consulted during the international search (name of data base and, where practicable, search terms used)  
EPO-Internal

Category*	Citation of document, with indication, where appropriate, of the relevant passages	Relevant to claim No.
X	US 2015/208443 A1 (JUNG JUNGSOO [KR] ET AL) 23 July 2015 (2015-07-23) paragraphs [0003], [0039], [0040], [0050]	1-20
A	----- US 2014/148107 A1 (MALTSEV ALEXANDER [RU] ET AL) 29 May 2014 (2014-05-29) paragraphs [0046], [0048], [0060], [0200]; figures 2,5,8	1-20
A	----- US 2013/100869 A1 (BOCH ERIK [CA]) 25 April 2013 (2013-04-25) paragraphs [0008], [0042], [0051], [0052], [0087], [0109], [0111] - [0128]; figures 7,8	1-20

Further documents are listed in the continuation of Box C.

See patent family annex.

\* Special categories of cited documents :

- "A" document defining the general state of the art which is not considered to be of particular relevance
- "E" earlier application or patent but published on or after the international filing date
- "L" document which may throw doubts on priority claim(s) or which is cited to establish the publication date of another citation or other special reason (as specified)
- "O" document referring to an oral disclosure, use, exhibition or other means
- "P" document published prior to the international filing date but later than the priority date claimed

- "T" later document published after the international filing date or priority date and not in conflict with the application but cited to understand the principle or theory underlying the invention
- "X" document of particular relevance; the claimed invention cannot be considered novel or cannot be considered to involve an inventive step when the document is taken alone
- "Y" document of particular relevance; the claimed invention cannot be considered to involve an inventive step when the document is combined with one or more other such documents, such combination being obvious to a person skilled in the art
- "&" document member of the same patent family

Date of the actual completion of the international search  28 October 2016	Date of mailing of the international search report  08/11/2016
--	--

Name and mailing address of the ISA/ European Patent Office, P.B. 5818 Patentlaan 2 NL - 2280 HV Rijswijk Tel. (+31-70) 340-2040, Fax: (+31-70) 340-3016	Authorized officer  Muntean, T
--	--------------------------------------

# INTERNATIONAL SEARCH REPORT

Information on patent family members

International application No PCT/EP2016/056634
---

Patent document cited in search report	Publication date	Patent family member(s)	Publication date	
US 2015208443	A1	23-07-2015	CN 104718712 A	17-06-2015
			EP 2887558 A1	24-06-2015
			JP 2015532805 A	12-11-2015
			KR 20140023690 A	27-02-2014
			US 2015208443 A1	23-07-2015
			WO 2014027868 A1	20-02-2014
-----				
US 2014148107	A1	29-05-2014	CN 105122664 A	02-12-2015
			EP 2926471 A1	07-10-2015
			US 2014148107 A1	29-05-2014
			WO 2014084912 A1	05-06-2014
-----				
US 2013100869	A1	25-04-2013	US 2009274130 A1	05-11-2009
			US 2013100869 A1	25-04-2013
			WO 2008037051 A1	03-04-2008
-----				