

May 17, 1960

T. T. SANO

2,936,936

SHEET MATERIAL DISPENSER

Filed May 29, 1959

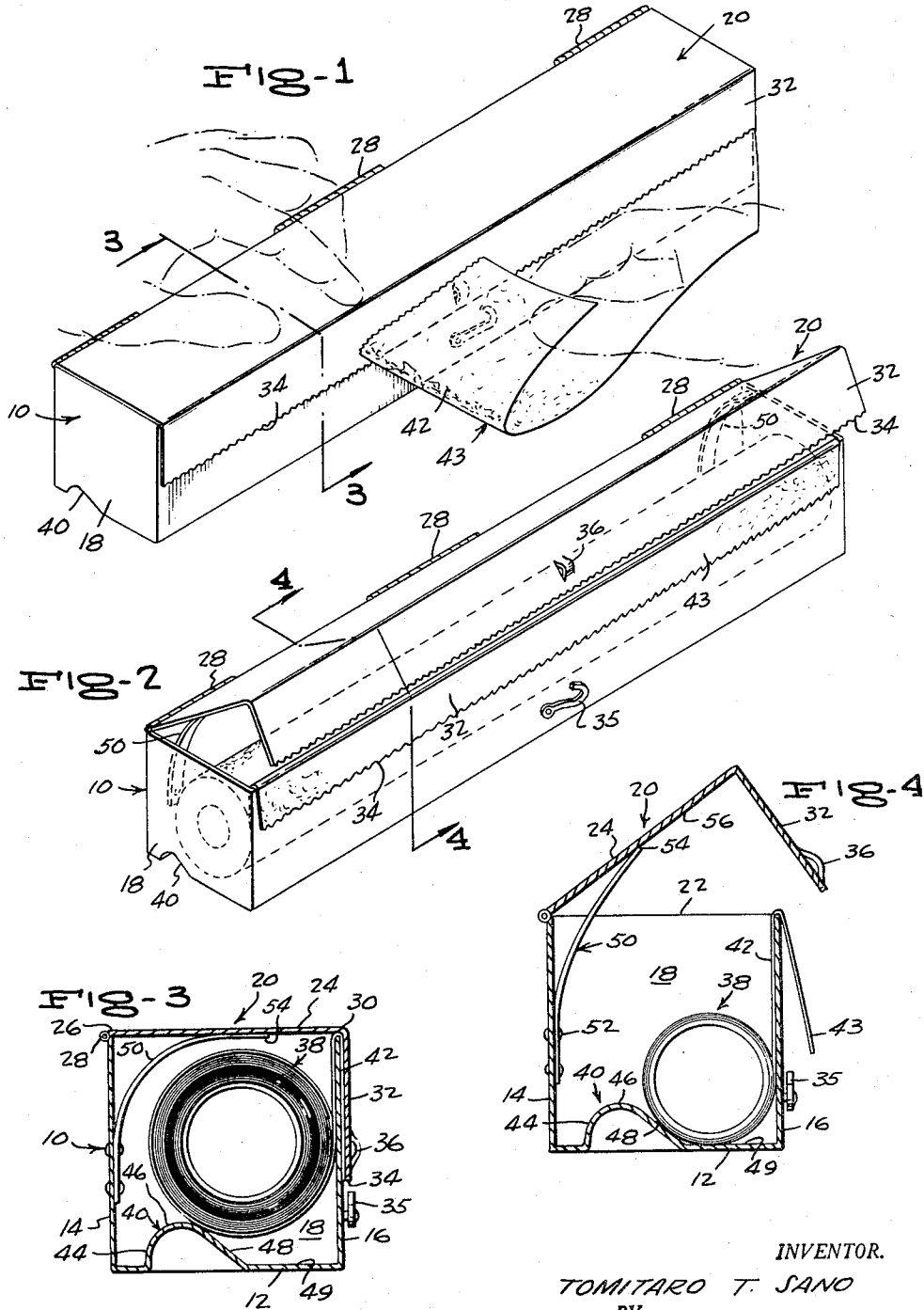

INVENTOR.

TOMITARO T. SANO
BY

McCormack, Porman + Davidson
ATTORNEYS

1

2,936,936

SHEET MATERIAL DISPENSER

Tomitaro T. Sano, Reedley, Calif.

Application May 29, 1959, Serial No. 816,833

3 Claims. (Cl. 225-43)

This invention relates to an improved dispenser for sheet material, such as roll paper.

The primary object of the invention is to provide a more practical and efficient device of the kind indicated, which has superior and more easily used sheet material cutting means, which serves also as means for positioning material for a subsequent cut, and which has means for preventing sidewise rolling of a sheet material roll therein, even after the roll has been consumed to a fraction of its starting diameter.

Another object of the invention is to provide a device of the character indicated above which has a hinged cover having a depending flange on its free edge, provided with a cutting edge, the flange serving in the closed position of the cover, to hold a length of sheet material between itself and the front of the container of the device, long enough to provide an adequate hand-hold for a dispensing and cutting operation, following a cutting operation done along the cutting edge of the flange with the cover in closed position.

A further object of the invention is to provide, in a device of the character indicated above, an arrangement wherein, in the closed position of the cover, the cover flange makes frictional engagement with a length of sheet material located between itself and the front of the container, so that the cover is maintained in closed position, and wherein spring means is provided for swinging the cover to open position when the cover is normally started toward open position.

Other important objects and advantageous features of the invention will be apparent from the following description and the accompanying drawings, wherein, for purposes of illustration only, a specific form of the invention is set forth in detail.

In the drawings:

Figure 1 is a schematic front perspective view of a device of the invention, showing an operator's left and right hands severally applied to depress the cover from open position and tear sheet material along the cutting edge;

Figure 2 is a front perspective view of said device showing the cover in open position;

Figure 3 is a transverse vertical section taken on the line 3-3 of Figure 1; and,

Figure 4 is a transverse vertical section taken on the line 4-4 of Figure 2.

Referring in detail to the drawings, wherein like numerals designate like parts throughout the several views, the illustrated dispenser comprises a horizontally elongated, rectangular open-top container 10, having a bottom wall 12, a back wall 14, and a front wall 16, extending between full height end walls 18, and a cover 20 for its open top.

The walls of the container 10 are all of the same height and have a common upper edge 22. The cover 20 comprises a top wall 24 of the full length of the container, and of a width slightly greater than the spacing of the back and front walls from each other. The cover wall

2

24 has a rear longitudinal edge 26 which is connected by hinge means, preferably in the form of longitudinally spaced hinges 28, to the upper edge of the back wall 14. The cover wall 24 has a front longitudinal edge 30 which reaches slightly forwardly beyond the front wall 16, when the cover is in closed position, as seen in Figure 3, and has on and along the front edge 30 a relatively deep depending flange 32, which has a serrated lower free cutting edge 34. As seen in Figure 3, the flange 32 is of a depth at least half the height of the front wall 16, and preferably somewhat deeper.

The container 10 and the cover 20 are made of relatively stiff sheet material having some resiliency and having sufficient rigidity and resistance to distortion in service, that the container will not be substantially collapsed by operation of the cover 20, and that the right-angular relationship between the cover wall 24 and the flange 32 will not be substantially altered in service. A centered pivoted latch hook 35 can be provided on the container front wall 16, below the flange 32, for engagement with a keeper eye 36 provided on the flange 32, for securing the cover 20 in closed position on the container 10.

The container bottom wall 12 has means thereon, within the container 10, for resisting crosswise or side to side rolling, in the container of a roll 38, of such as paper toweling and the like, even after the diameter of the roll has become a fraction of the starting diameter, as a result of dispensing of material from the roll. The roll means can take the form of an upstanding or longitudinal rounded ridge 40, spaced from the back wall 14 and the front wall 16, and preferably in the form of an upward indentation of the bottom wall. The indentation 40 is spaced closer to the back wall 14 than to the front wall 16, as seen in Figure 3, so that the roll 38 will always be larger in diameter than the distance between the indentation and the back wall, and be thereby prevented from ever lodging between the indentation and the back wall 14, and so as to be thereby forced to occupy a forward position in a roll seat 49 formed between the indentation and the front wall 16. In such forward position, the roll 38, and the strip 42 coming off the bottom of the roll, are held against the front wall, instead of merely reaching at an angle from the roll to the upper edge of the front wall 16.

The indentation 40 is preferably formed to have arcuate rear and top portions 44, 46 and a forwardly declining, substantially flat forward ramp portion 48, so that, as seen in Figure 3, a full roll 38 rests upon the top portion 46, and a depleted roll rests upon the ramp portion 48, as shown in Figure 4. As also shown in Figure 4, a dispensing operation is prepared for and initiated by pulling the strip 42 off the underside of the roll 38, over the upper edge of the front wall 16 and down along the front side of the front wall 16, with the cover 20 in open position.

For holding the cover 20 up in open position, spring means is provided, which preferably comprises a vertically elongated, upwardly and forwardly bowed spring leaf 50 which is fixed at its lower end, as indicated at 52, to an intermediate height part of the front of the back wall 14. The spring leaf has a free upper end 54 reaching above the upper edge 22 of the container 10, and bearing slidably against an intermediate part of the undersurface 56 of the cover wall 24. More than one spring 50, such as one at each of the containers 10 can be provided, if desired.

A dispensing operation having been prepared, as described above, and shown in Figure 4, the operator pulls down on the terminal edge portion 43 of the strip 42, until the desired length of strip 42 has been pulled out, whereupon the cover 20 is depressed with one hand

against the resistance of the spring leaf 50, as shown in Figures 1 and 3, until the cover flange 32 comes down and frictionally clamps the strip 42 between itself and the front side of the container front wall 16, as shown in Figures 1 and 3, whereat the dispensed length of strip 42 is torn off along the cutting edge 34 with the other hand.

Because of the designedly deep flange 32 and the frictional retention of a corresponding long length of strip 42 therebeneath along the container front wall 16, opening of the cover 20, preparatory to a following dispensing operation, leaves said long length of strip as an adequate handhold for pulling out more strip. Opening of the cover 20 is done manually, as by pushing up on the keeper eye 36, until the frictional grip of the flange 32 on the strip 42 on the front of the container 10 is sufficiently reduced to enable the spring leaf 50 to complete the opening of the cover 20 and hold it open for a following closing of the cover.

While there has been shown and described herein a preferred form of the invention, it is to be understood that the invention is not necessarily confined thereto, and that any change or changes in the structure of and in the relative arrangements of components thereof are contemplated as being within the scope of the invention as defined by the claims appended hereto.

What is claimed is:

1. A sheet material dispenser comprising an elongated open-top container having a bottom wall, a back wall, a front wall, and end walls, a cover comprising a top wall of the length of the container and of a width slightly greater than that of the container, said cover top wall having a rear longitudinal edge hinged on the upper edge of the back wall and a forward longitudinal edge reaching slightly forwardly beyond the front wall, a depending flange on and extending along said forward edge, said flange being of a depth to reach relatively far downwardly below the upper edge of the front wall when the cover is in closed position and having a free lower cutting edge, said flange being of limited resilience and being resistant to distortion out of a right-angular relation to the cover top wall, a sheet material roll within the container having a strip of material pulled over the upper edge of the container front wall and down along the front side of the front wall, said cover flap being rearwardly tensioned toward the front wall so as to frictionally hold the strip between itself and the front wall, and an upstanding longitudinal non-roll ridge on the container bottom wall, said ridge being spaced from the back wall at a distance less than the roll and spaced from the front wall at a distance to provide a seat for the roll between the ridge and the front wall.

2. A sheet material dispenser comprising an elongated open-top container having a bottom wall, a back wall, a front wall, and end walls, a cover comprising a top wall of the length of the container and of a width slightly greater than that of the container, said cover top wall having a rear longitudinal edge hinged on the upper edge of the back wall and a forward longitudinal edge reaching slightly forwardly beyond the front wall, a depending flange on and extending along said forward edge,

said flange being of a depth to reach relatively far downwardly below the upper edge of the front wall when the cover is in closed position and having a free lower cutting edge, said flange being of limited resilience and being resistant to distortion out of a right angular relation to the cover top wall, a sheet material roll within the container having a strip of material pulled over the upper edge of the container front wall and down along the front side of the front wall, said cover flap being rearwardly tensioned toward the front wall so as to frictionally hold the strip between itself and the front wall, and upstanding longitudinal non-roll ridge on the container bottom wall, said ridge being spaced from the back wall at a distance less than the roll and spaced from the front wall at a distance to provide a seat for the roll between the ridge and the front wall, said ridge comprising an upward indentation of the bottom wall, said indentation having convex arcuate rear and top portions and a flat forwardly declining forward ramp portion.

3. A sheet material dispenser comprising an elongated open-top container having a bottom wall, a back wall, a front wall, and end walls, a cover comprising a top wall of the length of the container and of a width slightly greater than that of the container, said cover top wall having a rear longitudinal edge hinged on the upper edge of the back wall and a forward longitudinal edge reaching slightly forwardly beyond the front wall, a depending flange on and extending along said forward edge, said flange being of a depth to reach relatively far downwardly below the upper edge of the front wall when the cover is in closed position and having a free lower cutting edge, said flange being of limited resilience and being resistant to distortion out of a right-angular relation to the cover top wall, and a sheet material roll within the container having a strip of material pulled over the upper edge of the container front wall and down along the front side of the front wall, said cover flap being rearwardly tensioned toward the front wall so as to frictionally hold the strip between itself and the front wall, an upstanding longitudinal non-roll ridge on the container bottom wall, said ridge being spaced from the back wall at a distance less than the roll and spaced from the front wall at a distance to provide a seat for the roll between the ridge and the front wall, cover opening spring means mounted within the container and operatively engaging the cover top wall, said spring means serving to move the cover to and hold the cover in upwardly hinged position, upon manual release of the frictional engagement of the cover flange from the roll strip on the front wall.

References Cited in the file of this patent

UNITED STATES PATENTS

1,593,529	Gibson et al. -----	July 20, 1926
1,659,985	Stroesser -----	Feb. 21, 1928
1,961,511	Sinclair -----	June 5, 1934
2,271,135	Crebbs -----	Jan. 27, 1942
2,776,052	Stevens -----	Jan. 1, 1957