

**(12) STANDARD PATENT**  
**(19) AUSTRALIAN PATENT OFFICE**

(11) Application No. **AU 2009221970 B2**

(54) Title  
**Installation-ready pipe coupling method of manufacture**

(51) International Patent Classification(s)  
**B21D 39/04** (2006.01)

(21) Application No: **2009221970**

(22) Date of Filing: **2009.03.03**

(87) WIPO No: **WO09/111464**

(30) Priority Data

(31) Number  
**12/042,769**

(32) Date  
**2008.03.05**

(33) Country  
**US**

(43) Publication Date: **2009.09.11**

(44) Accepted Journal Date: **2014.03.13**

(71) Applicant(s)  
**Victaulic Company**

(72) Inventor(s)  
**Gibb, John;Dole, Douglas R.**

(74) Agent / Attorney  
**Spruson & Ferguson, L 35 St Martins Tower 31 Market St, Sydney, NSW, 2000**

(56) Related Art  
**US 7086131**

(12) INTERNATIONAL APPLICATION PUBLISHED UNDER THE PATENT COOPERATION TREATY (PCT)

(19) World Intellectual Property Organization  
International Bureau



(43) International Publication Date  
11 September 2009 (11.09.2009)

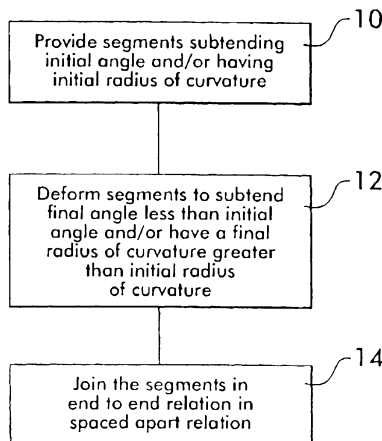
(10) International Publication Number  
**WO 2009/111464 A1**

- (51) International Patent Classification:  
*B21D 39/04* (2006.01)
- (21) International Application Number:  
PCT/US2009/035865
- (22) International Filing Date:  
3 March 2009 (03.03.2009)
- (25) Filing Language: English
- (26) Publication Language: English
- (30) Priority Data:  
12/042,769 5 March 2008 (05.03.2008) US
- (71) Applicant (for all designated States except US): **VIC-TAULIC COMPANY** [US/US]; 4901 Kesslersville Road, Easton, PA 18040 (US).
- (72) Inventors; and
- (75) Inventors/Applicants (for US only): **GIBB, John** [CA/CA]; 24 Coburn Crescent, Beeton, Ontario, LOG 1A0 (CA). **DOLE, Douglas, R.** [US/US]; 9 Minsi Road, Whitehouse Station, NJ 08889 (US).
- (74) Agents: **CHIONCHIO, John, A.** et al.; Ballard Spahr Andrews & Ingersoll, LLP, Suite 1000, 999 Peachtree Street, Atlanta, GA 30309-3915 (US).

- (81) Designated States (unless otherwise indicated, for every kind of national protection available): AE, AG, AL, AM, AO, AT, AU, AZ, BA, BB, BG, BH, BR, BW, BY, BZ, CA, CH, CN, CO, CR, CU, CZ, DE, DK, DM, DO, DZ, EC, EE, EG, ES, FI, GB, GD, GE, GH, GM, GT, HN, HR, HU, ID, IL, IN, IS, JP, KE, KG, KM, KN, KP, KR, KZ, LA, LC, LK, LR, LS, LT, LU, LY, MA, MD, ME, MG, MK, MN, MW, MX, MY, MZ, NA, NG, NI, NO, NZ, OM, PG, PH, PL, PT, RO, RS, RU, SC, SD, SE, SG, SK, SL, SM, ST, SV, SY, TJ, TM, TN, TR, TT, TZ, UA, UG, US, UZ, VC, VN, ZA, ZM, ZW.
- (84) Designated States (unless otherwise indicated, for every kind of regional protection available): ARIPO (BW, GH, GM, KE, LS, MW, MZ, NA, SD, SL, SZ, TZ, UG, ZM, ZW), Eurasian (AM, AZ, BY, KG, KZ, MD, RU, TJ, TM), European (AT, BE, BG, CH, CY, CZ, DE, DK, EE, ES, FI, FR, GB, GR, HR, HU, IE, IS, IT, LT, LU, LV, MC, MK, MT, NL, NO, PL, PT, RO, SE, SI, SK, TR), OAPI (BF, BJ, CF, CG, CI, CM, GA, GN, GQ, GW, ML, MR, NE, SN, TD, TG).

Published: — with international search report (Art. 21(3))

(54) Title: INSTALLATION-READY PIPE COUPLING METHOD OF MANUFACTURE



**F I G I**

(57) Abstract: A method of manufacturing an installation-ready pipe coupling is disclosed. The method includes providing pipe coupling segments each having an initial radius of curvature and an initial subtended angle. The segments are each deformed so as to take a permanent set and have a final radius of curvature greater than the initial radius of curvature and a final subtended angle smaller than the initial subtended angle. The deformed segments are assembled in end-to-end relation using adjustably tightenable fasteners to form a coupling. The deformed segments are maintained in spaced relation so that pipe elements can be inserted between them without disassembly of the coupling.

WO 2009/111464 A1

## INSTALLATION-READY PIPE COUPLING METHOD OF MANUFACTURE

### Field of the Invention

This invention concerns a method of manufacturing mechanical pipe couplings that are  
5 ready to be installed without the need for disassembly and reassembly.

### Background of the Invention

Mechanical couplings for joining pipe elements together end-to-end comprise  
interconnectable segments that are positionable circumferentially surrounding the end portions of  
10 co-axially aligned pipe elements. The term "pipe element" is used herein to describe any pipe-  
like item or component having a pipe like form. Pipe elements include pipe stock, pipe fittings  
such as elbows, caps and tees, as well as fluid control components such as valves, reducers,  
strainers, restrictors, pressure regulators and the like.

Each mechanical coupling segment comprises a housing having arcuate surfaces which  
15 project radially inwardly from the housing and engage the outer surfaces of the pipe elements to  
be joined. Such pipe elements include plain end, grooved, beaded as well as shouldered  
configurations. Engagement between the arcuate surfaces and the pipe elements provides  
mechanical restraint to the joint and ensures that the pipe elements remain coupled even under  
20 high internal pressure and external forces. The housings define an annular channel between the  
arcuate surfaces that receives a gasket or seal, typically an elastomeric ring, which engages the  
ends of each pipe element and cooperates with the segments to provide a fluid-tight seal. The  
segments have connection members, typically in the form of lugs which project outwardly from  
the housings. The lugs are adapted to receive fasteners, such as nuts and bolts, which are  
25 adjustably tightenable to draw the segments toward one another.

To ensure a good fit between the couplings and the pipe elements, the arcuate surfaces on  
prior art couplings have a radius of curvature that is substantially matched to the radius of  
curvature of the outer surface of the pipe element that it is intended to engage. For couplings  
30 used with grooved pipe elements, the radii of curvature of the arcuate surfaces are smaller than  
the radii of curvature of the outer surfaces of the pipe elements outside of the grooves so that the  
arcuate surfaces fit within and engage the grooves properly. For couplings used with shouldered  
or beaded pipe elements, the radii of curvature are sized to engage the outer diameter of the pipe  
adjacent to the bead or shoulder.

This geometrical relation between the arcuate surfaces of the couplings and the outer surfaces of the pipe elements in prior art couplings results in a time consuming installation process when mechanical couplings are used. Typically, the coupling is received by the technician with the segments bolted together and the ring seal captured within the segments' channels. The technician first disassembles the coupling by unbolting it, removes the ring seal, lubricates it (if not pre-lubricated) and places it around the ends of the pipe elements to be joined. Installation of the ring seal requires that it be lubricated and frequently stretched to accommodate the pipe elements, an often messy task, as the lubrication makes manual manipulation of the seal difficult. With the ring seal in place on both pipe elements, the segments are then placed one at a time straddling the ends of the pipe elements and capturing the ring seal against them. During placement, the segments engage the seal, the arcuate surfaces are aligned with the grooves, beads or shoulders (when present), the bolts are inserted through the lugs, the nuts are threaded onto the bolts and tightened, drawing the coupling segments toward one another, compressing the seal and engaging the arcuate surface within the grooves.

As evident from the previous description, installation of mechanical pipe couplings according to the prior art requires that the technician typically handle at least seven individual piece parts (and more when the coupling has more than two segments) and must totally disassemble and reassemble the coupling. Significant time, effort and expense would be saved if the technician could install a mechanical pipe coupling without first totally disassembling it and then reassembling it, piece-by-piece.

### **Object of the Invention**

It is an object of the present invention to substantially overcome or at least ameliorate one or more of the disadvantages of the prior art, or to at least provide a useful alternative.

### **Summary of the Invention**

In a first aspect of the present disclosure, there is provided a method of manufacturing an installation ready pipe coupling for joining pipe elements in end-to-end relation, said method comprising:

providing a plurality of segments, each of said segments having a pair of contact surfaces adapted to interface with the outer surfaces of said pipe elements, said contact surfaces being in spaced apart side by side relation, said segments subtending an initial angle; and

deforming each of said segments into a deformed shape subtending a final angle, wherein said final angle is less than said initial angle, said segments maintaining said deformed shape.

In a second aspect of the present disclosure, there is provided a method of manufacturing an installation ready pipe coupling for joining pipe elements in end-to-end relation, said method comprising:

providing a plurality of segments, each of said segments having a pair of arcuate contact surfaces adapted to interface with the outer surfaces of said pipe elements, said arcuate contact surfaces being in spaced apart side by side relation, said arcuate contact surfaces having an initial radius of curvature; and

deforming each of said segments into a deformed shape wherein said arcuate contact surfaces have a final radius of curvature, said final radius of curvature being greater than said initial radius of curvature, said segments maintaining said deformed shape.

In a third aspect of the present disclosure, there is provided a method of manufacturing an installation ready pipe coupling for joining pipe elements in end-to-end relation, said method comprising:

providing a plurality of segments, each of said segments having a pair of contact surfaces adapted to interface with the outer surfaces of said pipe elements, said contact surfaces being in spaced apart side by side relation, said contact surfaces having first and second ends oppositely disposed and positioned at an initial distance apart from one another; and

deforming each of said segments into a deformed shape wherein said first and second ends of said contact surfaces are positioned at a final distance apart from one another, said final distance being greater than said initial distance, said segments maintaining said deformed shape.

In a particular embodiment, deforming of the segments may comprise:

- (a) providing a tool having at least one surface engageable with each of the segments;
- (b) engaging each of the segments with the tool; and
- (c) forcing each of the segments and the tool against one another such that each of the segments deforms to subtend the final angle and/or have the final radius of curvature when the segments are removed from the tool.

In another embodiment of the method, deforming of the segments comprises bending effected by:

- (a) supporting each of the segments at two support points in spaced relation lengthwise along each of the segments; and
- (b) applying a force transversely to each of the segments at a point located between the two support points.

The method further comprises assembling the installation-ready coupling by joining at least two of the segments in end-to-end relation such that the contact surfaces are in facing relation surrounding a center space. The segments may be joined using adjustably tightenable fasteners. Preferably, the segments are maintained in spaced apart relation after joining. A ring shaped seal may be positioned between the segments. The seal has an outer surface which supports the segments and maintains them in the desired spaced apart relation.

Preferably, the initial and final angles and the radius of curvature are measured at the contact surfaces, which are preferably arcuate in shape.

### **Brief Description of the Drawings**

Preferred embodiments of the invention will be described hereinafter, by way of examples only, with reference to the accompanying drawings.

Figure 1 is a flow chart illustrating a method of manufacturing an installation-ready coupling;

Figures 2-4 and 2A-4A are schematic illustrations depicting an embodiment of a method of manufacturing an installation-ready coupling;

Figures 5-9 are schematic illustrations depicting another embodiment of a method of manufacturing an installation-ready coupling;

Figure 10 is a flow chart illustrating another method of manufacturing an installation-ready coupling;

2009221970 17 Feb 2014

4a

Figures 11 and 12 show a pipe coupling segment deformed according to the method described in Figure 10;

Figure 13 is a partial sectional end view of an installation-ready coupling; and

Figures 14-17 show assembly of a joint using an installation-ready coupling.

### Detailed Description of the Embodiments

Figure 1 is a flow chart which illustrates a method of manufacturing an installation-ready pipe coupling according to the invention. As seen in box 10, a plurality of segments are provided. The segments are typically cast from ductile iron but could also be formed of other metals such as copper, steel, aluminum malleable iron, stainless steel, copper-nickel alloy as well as plastics such as PVC and CPVC. For the process to be effective, the material from which the segments are formed must be capable of plastically deforming and taking a permanent set into a first deformed shape without cracking or manifesting other modes of failure. The material must also be capable of deforming again without failing, although not necessarily plastically, when in use.

The segments have portions which subtend an initial angle and/or have an initial radius of curvature. As noted in box 12, the segments are deformed so that the subtended angle decreases and/or the radius of curvature increases. The segments are permanently deformed in this manner, meaning that they are stressed beyond their elastic limit so that they take a permanent set and assume the smaller subtended angle and/or the larger radius of curvature.

In box 14, the segments are assembled into couplings by attaching the segments in end-to-end relation using tightenable fasteners. The segments are assembled and maintained in spaced apart relation, for example, by using a seal to support the segments. The spacing between the segments is chosen to allow pipe elements to be inserted between the segments without having to disassemble the coupling. Once the pipe elements are positioned properly within the coupling, the fasteners are tightened. The segments are drawn toward the pipe elements and are engaged with them. The segments deform as a result of the tightening of the fasteners and engagement with the pipe elements, the deformation now increasing the subtended angle and/or decreasing the radius of curvature.

Figures 2-4 show one method of deforming a representative segment 16. A tool 18 is provided, the tool having a radius of curvature 20 which is larger than the final radius of curvature desired for the segment 16. The tool radius of curvature 20 may be somewhat larger to compensate for spring-back from the deformed shape, which often occurs when an elastic material is deformed plastically. There is almost always a portion of the material for which the stress induced by the deforming forces does not exceed the elastic limit. This portion of the



material does not deform plastically and its elastic properties act to return the segment partially to its original undeformed shape.

In Figure 2, the segment 16 is shown engaged with the tool 18. In this example the  
5 segment subtends an initial angle 22 of about  $180^\circ$ , and it rides high on the tool because its initial  
radius of curvature 24 is less than the radius of curvature 20 of the tool 18. As shown in Figure  
3, a ram 26 engages the segment 16 and forces it against the tool 18. The ram is preferably  
actuated hydraulically, although mechanical rams are also feasible. The segment deforms both  
10 elastically and plastically as a result and conforms to the shape of the tool. While engaged under  
force, the segment 16 has the same radius of curvature as the tool. Because it is forced to assume  
a larger radius of curvature, the subtended angle becomes smaller.

As shown in Figure 4, the ram 26 is disengaged and the segment 16 is released from the  
tool 18. The segment has been deformed plastically and takes a permanent set, with a final  
15 radius of curvature 28 larger than the initial radius of curvature 24, and a final subtended angle  
30 smaller than the initial angle 22. For an initial subtended angle 22 of  $180^\circ$  final subtended  
angles 30 between about  $170^\circ$  and about  $178^\circ$  are feasible. For practical segments the final  
radius of curvature may be between about 5% and about 10% greater than the initial radius of  
curvature.

20

Figures 2A, 3A and 4A illustrate the steps as described above for Figures 2-4, but for a  
segment 16 which subtends an initial angle 22 of  $120^\circ$ . A coupling would have three such  
segments joined end-to-end. The process is essentially the same as for the  $180^\circ$  segment shown  
in Figures 2-4, however, with an initial subtended angle 22 of about  $120^\circ$  the final subtended  
25 angle 30 will preferably be between about  $112^\circ$  and about  $119^\circ$ .

Figures 5-7 show another method of deforming the segments 16 in the method of making  
an installation-ready coupling. These figures illustrate a three point bending method. As shown  
in Figure 5, the segment 16, having its initial radius of curvature 24 and subtended angle 22, is  
30 supported at each end by supports 32 and 34. As shown in Figure 6, the ram 26 engages the  
segment somewhere between the supports, preferably midway between them. The ram applies a  
force transverse to the segment, bending the segment plastically and forcing it to assume a  
deformed shape having a greater radius of curvature 36 (the "intermediate radius of curvature")  
and a smaller subtended angle 38 (the "intermediate subtended angle"). Once the proper angular

deflection has been achieved, the ram 26 is removed (see Figure 7) and the segment is removed from supports 32 and 34. The force applied by the ram has resulted in the segment taking a permanent set with a final radius of curvature 28 greater than the initial radius of curvature 24 and a final subtended angle 30 less than the initial subtended angle 22. The final radius of curvature 28 may be less than or equal to the intermediate radius of curvature 36 depending on the amount of spring back in the segment 16. Similarly, the final subtended angle 30 may also be greater than or equal to the intermediate subtended angle 38, again depending on the degree of spring back in the segment.

Figure 8 schematically illustrates another method of deforming a segment 16. In this example, tension forces 17 are applied at opposite ends in opposite directions. Application of such forces may be effected hydraulically using fixtures to engage the lugs 42 which provide convenient attachment points. Figure 9 illustrates yet another deforming method, whereby an outwardly expanding force 19 is applied between the ends of each segment 16. Again, appropriate fixturing is necessary to effectively apply the deforming force 19.

It is understood that the radii of curvature 24, 28 and 36 may be measured with respect to any convenient point on the segment 16. It is advantageous to measure these radii with respect to concave arcuate surfaces such as 40, which project inwardly and are adapted to contact the outer surfaces of the pipe elements being joined by the coupling as discussed below. Similarly, it is advantageous to measure the subtended angles 22, 30 and 38 with respect to the contact surfaces 40. Alternately, there are lugs 42 at each end of the segments which can be used as the reference datum for the determination of the subtended angles.

Figure 10 presents another flow chart which describes an alternate method of manufacturing an installation ready pipe coupling. As described in box 11, segments having contact surfaces with ends positioned at an initial distance apart from one another are provided. An example of such a segment 16 is shown in Figure 11, wherein contact surfaces 40 have oppositely disposed ends 41 and 43 separated by an initial distance 45. With reference again to Figure 10, as explained in box 13, the segments are deformed, for example by any of the aforementioned techniques (forced engagement with a tool or three point bending method), so that the ends of the contact surfaces are at a final distance apart from one another, the final distance being greater than the initial distance. This is further illustrated in Figure 12 wherein segment 16 is shown in a deformed shape with ends 41 and 43 positioned at a final distance 47

which is greater than the initial distance 45 shown in Figure 11. In a practical embodiment, the final distance 47 is between about 5% to about 10% greater than the initial distance 45. Box 15 in Figure 10 describes that the segments are joined in end-to-end relation to construct a coupling as explained in detail below.

5

As shown in Figure 13, the segments 16, in their deformed shape, are assembled to form a coupling 42. The assembly process comprises joining at least two segments 16 in end-to-end relation and securing them to one another using adjustably tightenable fasteners, such as bolts 44 and nuts 46. The installation-ready aspect of the coupling is afforded by the deformed shape and the fact that the segments are maintained in spaced apart relation to allow pipe elements (for which the coupling is sized) to be inserted between the segments as described below. The segments are preferably maintained in spaced relation by a seal 48 positioned between them. Seal 48 has an outer surface 50 which supports the segments and maintains them in spaced apart relation. Other forms of spacers are also feasible. Notches 52, shown in phantom line, may also be positioned at opposite ends of the segments to provide additional clearance for pipe element insertion. The presence of notches reduces the degree of separation required between the segments and allows for fasteners of reasonable length. U.S. Patent No. 7,086,131 to Gibb et al describes these various aspects of the coupling and is hereby incorporated by reference herein.

The preassembled, installation-ready coupling is supplied as shown in Figure 13. In use, as shown in Figures 14 and 15, pipe elements 54 and 56 are inserted between the segments 16 without the need for any disassembly thanks to their deformed shape, separation and notches 52 (if present). For the joining of grooved pipe as shown, the contact surfaces 40 of the segments are aligned with grooves 58. As shown in Figures 16 and 17, the fasteners (bolts 44 and nuts 46) are tightened, drawing the segments toward one another and into engagement with the pipe elements. Tightening of the fasteners deforms the segments 16 so that the contact surfaces 40 thereon engage the outer surface of the pipe within the grooves 58 substantially over their entire arc length. The force applied by the fasteners is reacted by the pipe elements and the segments are deformed to a smaller radius of curvature and a larger subtended angle as determined by their engagement with the groove surfaces.

In a practical example of an installation ready pipe coupling for use with a pipe having a 2 inch nominal outer diameter (2.375 inch actual outer diameter), the contact surface's final radius of curvature for the deformed shape (before tightening of the fasteners) is about 1.22

inches and the radius when tightened in pad to pad engagement is about 1.12 inches.

Alternately, this may be expressed as a function of the distance between the ends of the contact surfaces. For use with the 2 inch nominal outer diameter pipe, in the deformed shape (before tightening), the final distance between the contact surface ends is 2.44 inches. The distance when  
5 the fasteners are tightened to bring the segments into pad to pad relation is 2.26 inches.

In another example of an installation ready pipe coupling, for a pipe having a 4 inch nominal outer diameter (4.5 inch actual outer diameter), the contact surface's final radius of curvature for the deformed shape (before tightening of the fasteners) is about 2.36 inches, and  
10 the radius when tightened in pad to pad engagement is about 2.16 inches. Alternately, this may be expressed as a function of the distance between the ends of the contact surfaces. For use with the 4 inch nominal outer diameter pipe, in the deformed shape (before tightening), the final distance between the contact surface ends is 4.71 inches. The distance when the fasteners are tightened to bring the segments into pad to pad relation is 4.35 inches.

15 Installation-ready pipe couplings manufactured according to the methods described herein provide a robust, rigid, fluid-tight joint while reducing the time and effort required for installation.

## CLAIMS

1. A method of manufacturing an installation ready pipe coupling for joining pipe elements in end-to-end relation, said method comprising:
  - providing a plurality of segments, each of said segments having a pair of contact surfaces adapted to interface with the outer surfaces of said pipe elements, said contact surfaces being in spaced apart side by side relation, said segments subtending an initial angle; and
  - deforming each of said segments into a deformed shape subtending a final angle, wherein said final angle is less than said initial angle, said segments maintaining said deformed shape.
2. A method according to Claim 1, wherein said initial angle is about  $180^\circ$ .
3. A method according to Claim 2, wherein said final angle is between  $170^\circ$  and  $178^\circ$ .
4. A method according to Claim 1, wherein said initial angle is about  $120^\circ$ .
5. A method according to Claim 4, wherein said final angle is between  $112^\circ$  and  $119^\circ$ .
6. A method according to Claim 1, wherein said deforming comprises:
  - providing a tool having at least one surface engageable with each of said segments;
  - engaging each of said segments with said tool; and
  - forcing each of said segments and said tool against one another such that each of said segments deforms to subtend said final angle when said segments are removed from said tool.
7. A method according to Claim 1, wherein said deforming comprises:

supporting each of said segments at two support points in spaced relation lengthwise along each of said segments; and

applying a force transversely to each of said segments at a point located between said two support points.

8. A method according to Claim 1, wherein said deforming comprises applying tension forces to opposite ends of said segments.

9. A method according to Claim 1, wherein said deforming comprises applying an outwardly expanding force between ends of each of said segments.

10. A method according to Claim 1, further comprising joining at least two of said segments in end-to-end relation such that said contact surfaces are in facing relation and surround a central space.

11. A method according to Claim 10, further comprising joining said segments using adjustably tightenable fasteners.

12. A method according to Claim 10, further comprising maintaining said segments in spaced apart relation after joining said segments.

13. A method according to Claim 12, further comprising positioning a ring shaped seal between said segments, said seal having an outer surface supporting said segments and maintaining them in said spaced apart relation.

14. A method according to Claim 1, wherein said contact surfaces comprise arcuate surfaces, said method further comprising measuring said initial and final angles at said arcuate surfaces.

15. A method of manufacturing an installation ready pipe coupling for joining pipe elements in end-to-end relation, said method comprising:

providing a plurality of segments, each of said segments having a pair of arcuate contact surfaces adapted to interface with the outer surfaces of said pipe elements, said arcuate contact surfaces being in spaced apart side by side relation, said arcuate contact surfaces having an initial radius of curvature; and

deforming each of said segments into a deformed shape wherein said arcuate contact surfaces have a final radius of curvature, said final radius of curvature being greater than said initial radius of curvature, said segments maintaining said deformed shape.

16. A method according to Claim 1, wherein said final radius of curvature is between 5% and 10% greater than said initial radius of curvature.

17. A method of manufacturing an installation ready pipe coupling for joining pipe elements in end-to-end relation, said method comprising:

providing a plurality of segments, each of said segments having a pair of contact surfaces adapted to interface with the outer surfaces of said pipe elements, said contact surfaces being in spaced apart side by side relation, said contact surfaces having first and second ends oppositely disposed and positioned at an initial distance apart from one another; and

deforming each of said segments into a deformed shape wherein said first and second ends of said contact surfaces are positioned at a final distance apart from one another, said final distance being greater than said initial distance, said segments maintaining said deformed shape.

18. A method according to Claim 17, wherein said final distance is between 5% and 10% greater than said initial distance.

19. A method according to Claim 17, wherein said deforming comprises:

providing a tool having at least one surface engageable with each of said segments;  
engaging each of said segments with said tool; and

forcing each of said segments and said tool against one another such that each of said segments deforms to position said first and second ends of said contact surfaces at said final distance apart.

20. A method according to Claim 17, wherein said deforming comprises:

supporting each of said segments at two support points in spaced relation lengthwise along each of said segments; and

applying a force transversely to each of said segments at a point located between said two support points.

21. A method according to Claim 17, wherein said deforming comprises applying tension forces to opposite ends of said segments.

22. A method according to Claim 17, wherein said deforming comprises applying an outwardly expanding force between ends of each of said segments.

23. A method according to Claim 17, further comprising joining said segments in end-to-end relation such that said contact surfaces are in facing relation surrounding a central space.

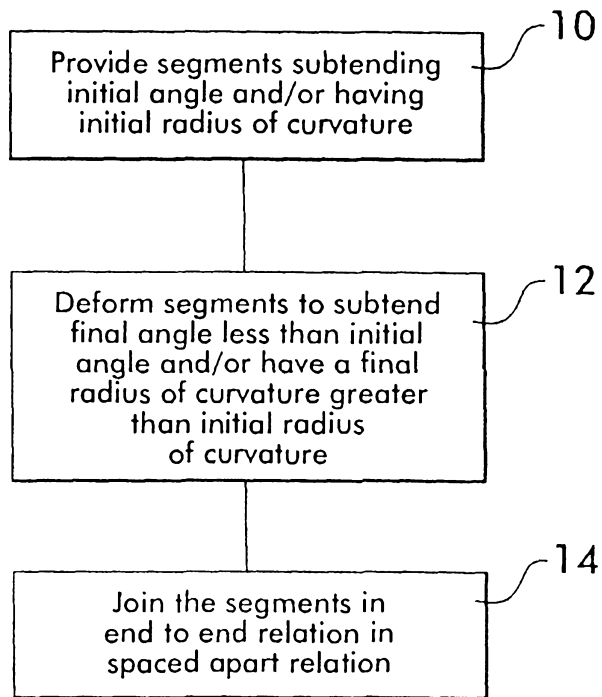
24. A method according to Claim 23, further comprising joining said segments using adjustably tightenable fasteners.

25. A method according to Claim 23, further comprising maintaining said segments in spaced apart relation after joining said segments.

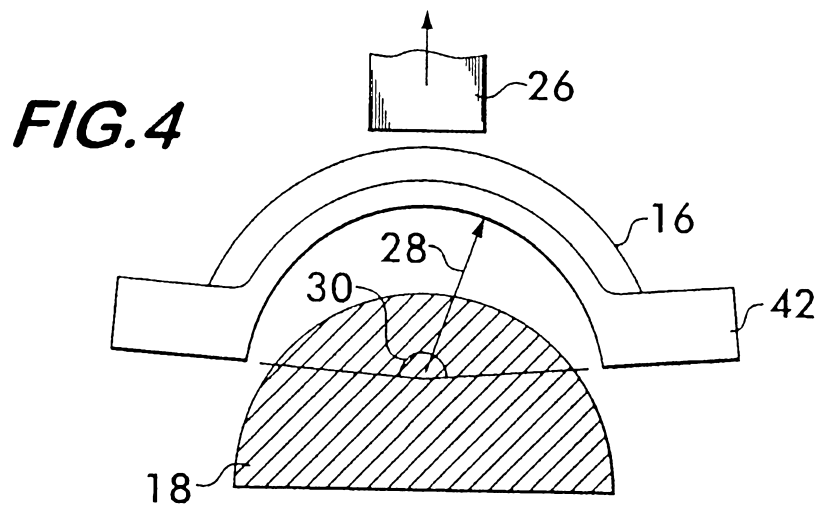
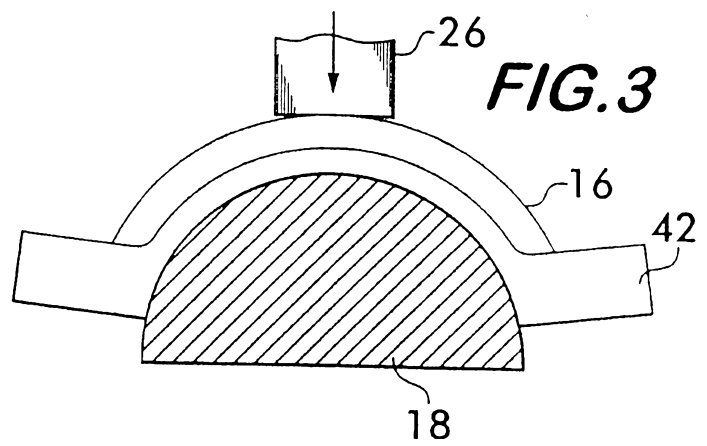
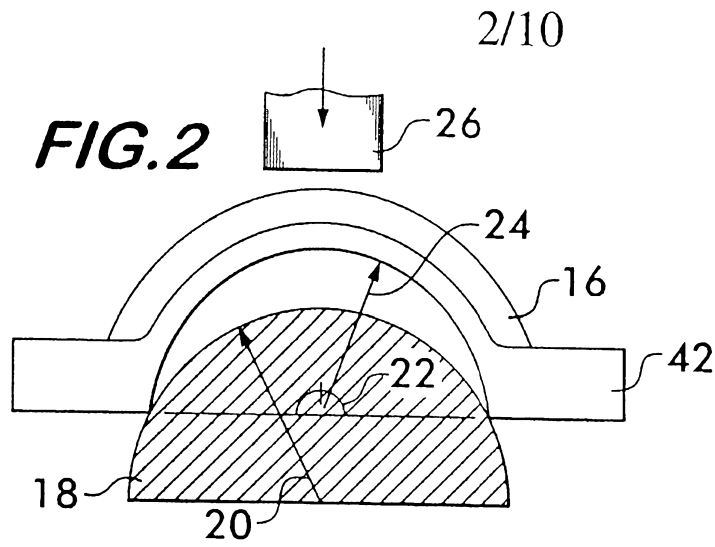
26. A method according to Claim 25, further comprising positioning a ring shaped seal between said segments, said seal having an outer surface supporting said segments and maintaining them in said spaced apart relation.



1/10

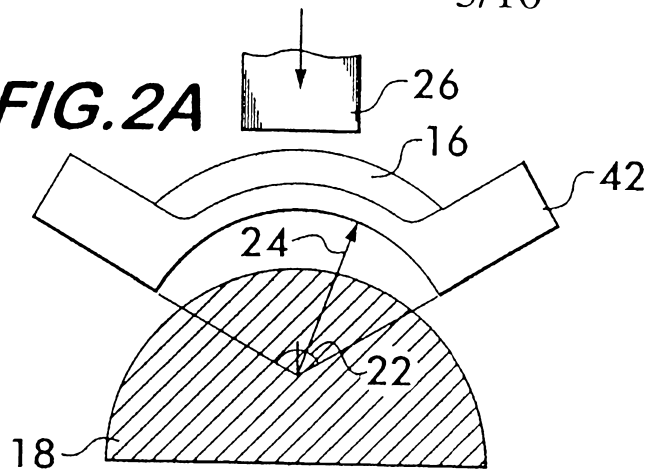


***FIG 1***

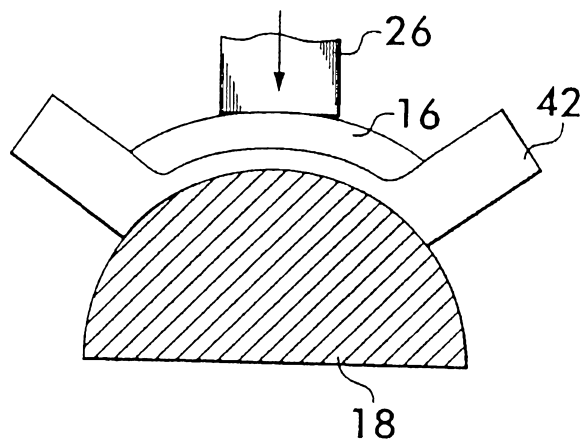


3/10

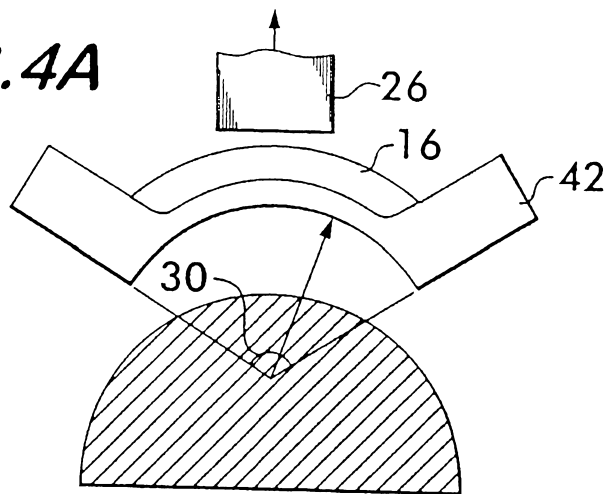
**FIG. 2A**

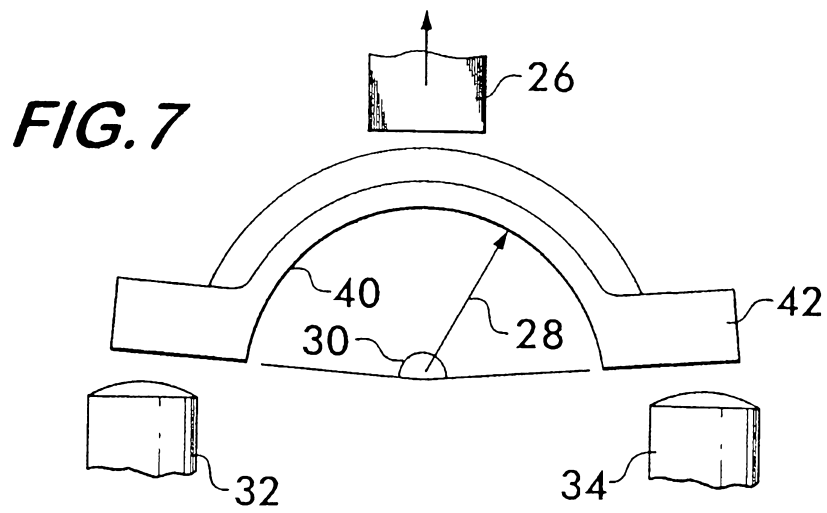
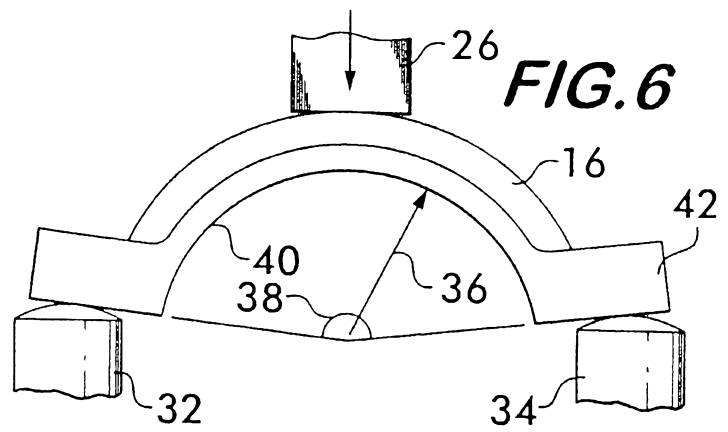
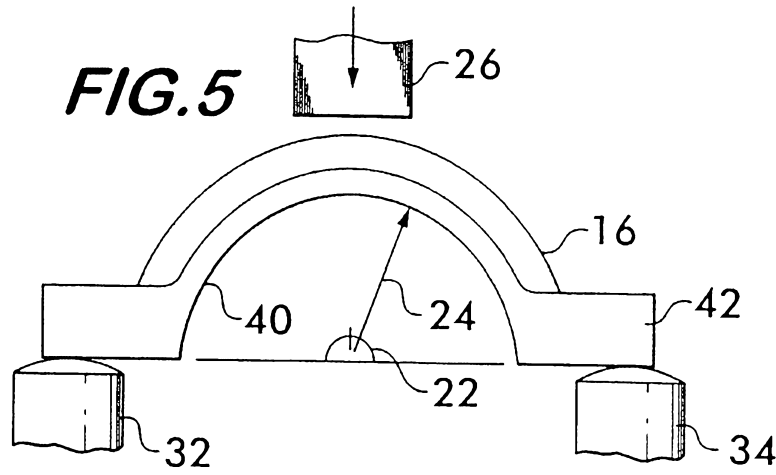


**FIG. 3A**

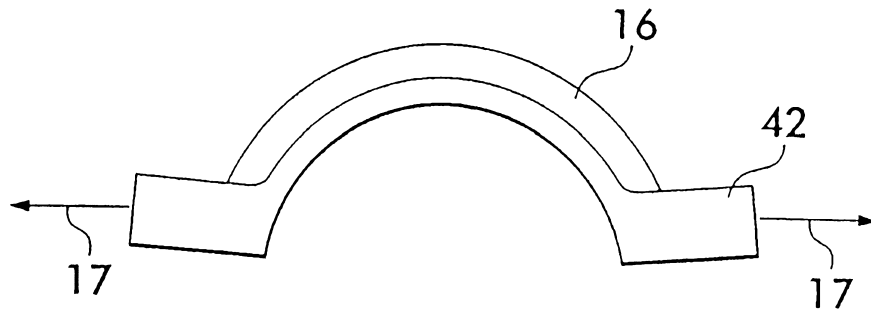


**FIG. 4A**

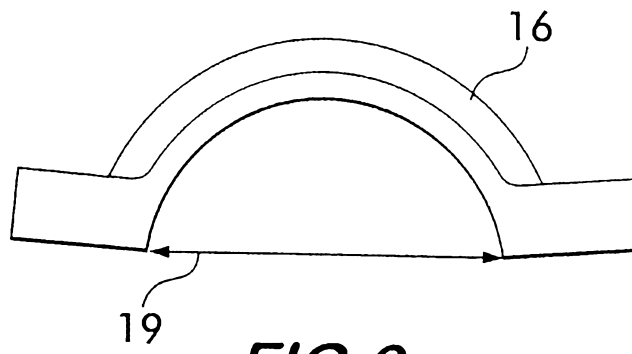




5/10

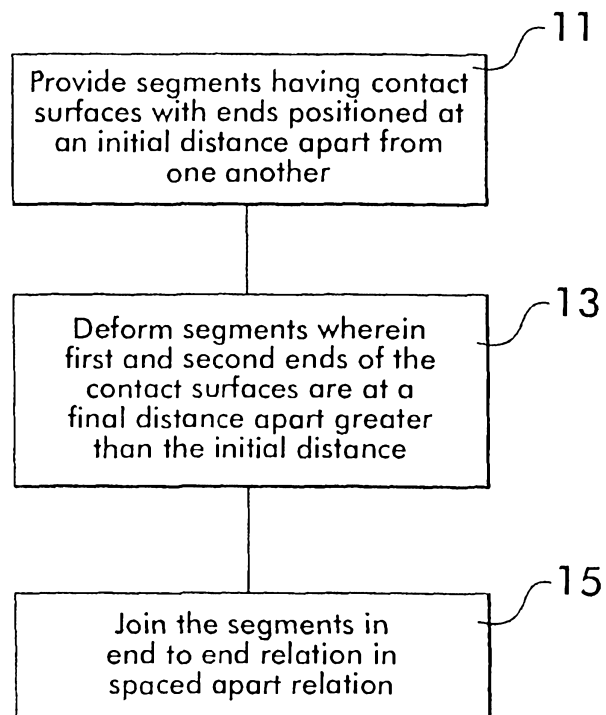


**FIG. 8**

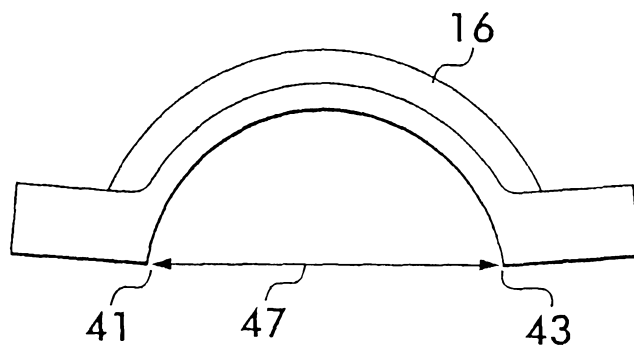
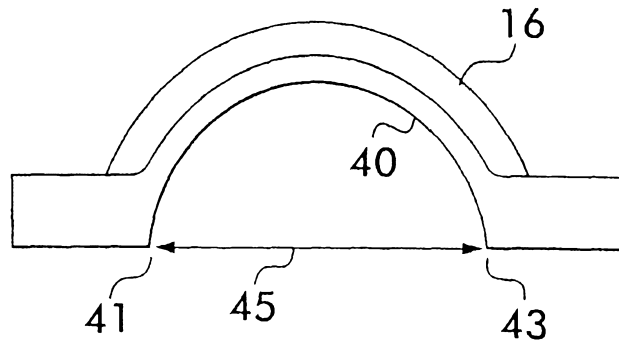


**FIG. 9**

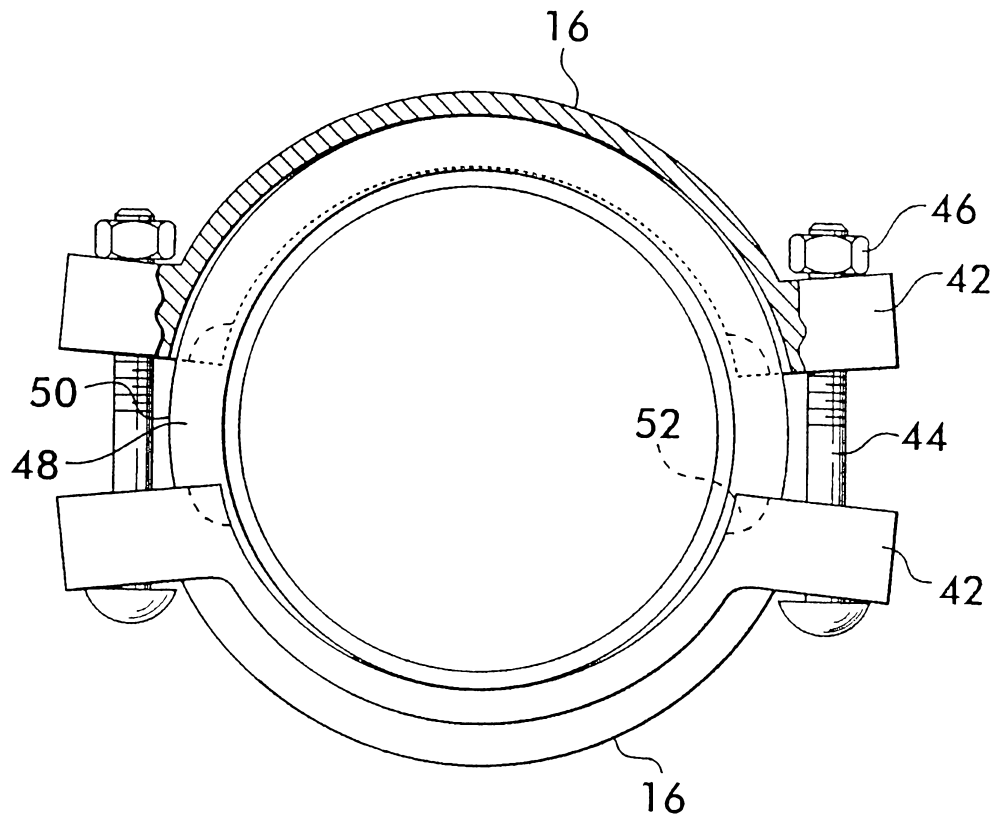
6/10

**FIG.10**

**FIG. II**



**FIG. I2**



**FIG. 13**



