

W. S DEEDS AND J P BRADWAY
 COMBINED ELLIPTICAL & CIRCULAR CUTTER

117611

PATENTED AUG 1 1871

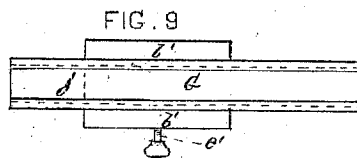
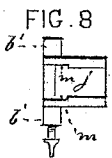
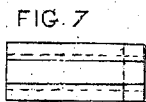
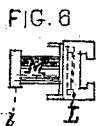
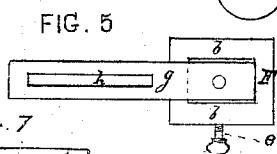
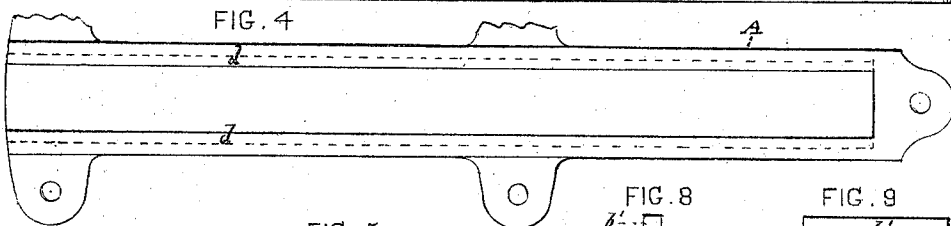
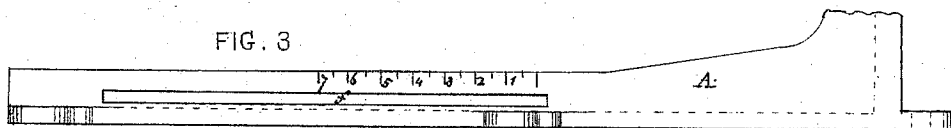
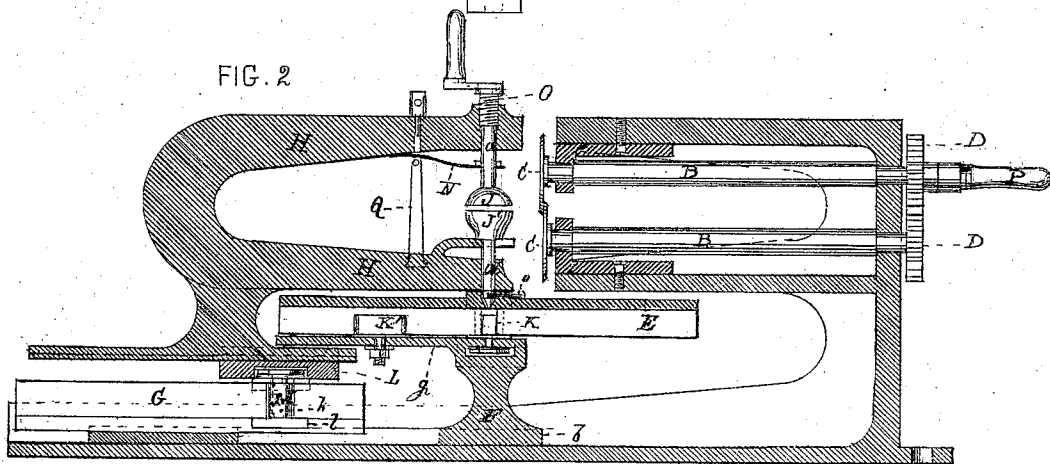
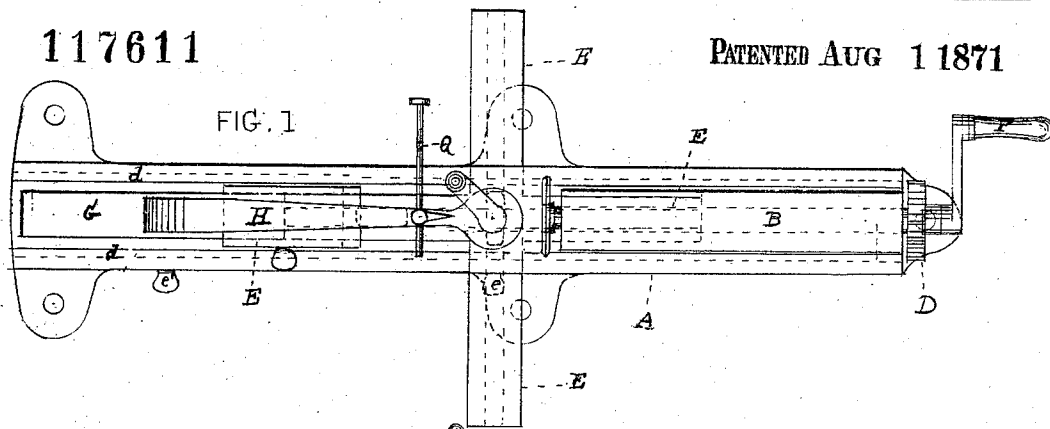

WITNESSES.

Thomas J. Dewey
 George F. Ward

INVENTORS.

William S. Deeds
 John P. Bradway
 By their Atty. Stephen West

UNITED STATES PATENT OFFICE.

WILLIAM S. DEEDS, OF BALTIMORE, MARYLAND, AND JOHN P. BRADWAY, OF PHILADELPHIA, PENNSYLVANIA.

IMPROVEMENT IN COMBINED CIRCULAR AND ELLIPTICAL CUTTERS.

Specification forming part of Letters Patent No. 117,611, dated August 1, 1871.

To all whom it may concern:

Be it known that we, WILLIAM S. DEEDS, of the city of Baltimore and State of Maryland, and JOHN P. BRADWAY, of the city of Philadelphia and State of Pennsylvania, have invented a Combined Elliptical and Circular Cutter, of which the following is a specification:

The primary object of our machine is the cutting of tin plates in elliptical and circular forms. It will answer, however, to cut photograph-cards, or other articles. The nature of the invention consists of a machine provided with a trammel-cross and clamp-holder, in combination with ordinary circular cutters, the said clamp-holder having an oscillatory and reciprocal movement in the operation of cutting ellipses, and the said cross and clamp-holder being stationary during the cutting of circles, as hereinafter described.

To enable others skilled in the art to which our improvement appertains to make and use our improved machine, we will now give a full description thereof.

In the accompanying drawing which makes a part of this specification, Figure 1 is a plan of the improved machine. Fig. 2 is a side elevation, partly in section, at the line *xx* of Fig. 1. Fig. 3 is a side elevation of the lower portion of the frame A. Fig. 4 is a top view of the same. Fig. 5 is a top view of the adjustable standard F. Figs. 6 and 7 are end and top views of the swivel-slide. Figs. 8 and 9 are top and edge views of the adjustable guide G.

Like letters in all the figures indicate the same parts.

A is the frame, to which the several parts of the machine are connected. B B are revolving cutter-shafts. C C are circular cutters on one end of the same. D D are gear-wheels on the other ends of the shafts, which connect them together. E is a trammel-cross. F is an adjustable standard on which it revolves. G is an adjustable guide connected with the bed-plate of the frame A. H is the clamp-holder. J J' are revolving clamps with disks, whose stems *a a'* turn freely in their bearings in the holder H, the lower stem *a'* having connection with the trammel E. The stand F, with which the trammel-cross E is connected by means of the revolving guides K K', has flanges *b b* that fit the grooves *d d* of the frame A to admit of the longitudinal adjustment of the stand, the latter being provided with a

set-screw, *e*, that has play in the longitudinal slot *f* in one side of the frame A. The arm *g* of the standard F has a vertical slot, *h*, seen in Fig. 5, which admits of the adjustment of the trammel-guide. The guide G, shown in detail in Figs. 8 and 9, has flanges *b' b'*, that fit in the grooves *d d*, above described, of the bed-plate A, to admit of the longitudinal adjustment of the guide, the same being provided with a set-screw, *e'*, which has play in the longitudinal slot *f*. We do not confine ourselves to fastening the standard E and guide G by means of the set-screws *e e'* and slot *f*, as they may be fastened in any convenient manner. The clamp-holder H is provided with an adjustable slide, L, which moves freely on the guide G in the reciprocating movement of the holder, the said slide being provided with a friction-roller, M, that rolls in the longitudinal vertical slot *j* of the guide, seen in Figs. 8 and 9, in the oscillatory movement of the holder H. The stud-pin *k*, which carries said roller, has a head, *l*, that slides in the longitudinal grooves *m m* at the bottom of the slot, whereby the slide is held in connection with the guide. The clamping-disk J is elevated a short distance above the clamping-disk J' by means of the spring N, connected with the clamp-holder H and the stem of the disk, as seen in Fig. 2, to admit of the placing of the sheet of tin to be cut between the clamps. The sheet is fastened by means of the screw O, which bears upon the end of the stems *a* of the disk J.

The operation of the machine is as follows: The standard F is so adjusted as to have its center in a vertical line equal in distance from the revolving cutters C C to one-half of the conjugate diameter of the ellipses to be cut. The center of the guide K' is set as far from the center of the guide K as the difference between one-half of the transverse and conjugate diameters of the ellipsis to be cut. The stem *a'* of the clamp J' is confined in the boss *n* of the trammel-cross E by means of the pin *o*; so as to cause the trammel to be carried around with the clamps to give the reciprocating movements of the tin to and from the cutters C C. The tin or other article to be cut is then placed in position between the clamping-disks J J' and the cutters C C revolved by means of the crank P on one of the gear-wheels D, and the action of the cutters upon the tin revolves the same and the trammel-cross E and gives the proper reciprocating movement to the

clamp-holder H for the cutting of the ellipsis. Q is a gauge connected with the clamp-holder H for the transverse diameter of the ellipsis. There is a scale on the frame A to guide in the adjustment of the standard F. A similar scale is on the edge of the arm *g* of the standard, which is used for the adjustment of the guide K'. By detaching the pin *o* from its connection with the trammel-cross E and the stem *a'* of the clamping-disk J', so as to prevent the turning of the cross, the machine may be used for cutting circles of various sizes by the proper adjustment of the standard E.

Heretofore, it has not been found practical to cut circles with elliptical cutters in consequence of the clamp-holder having to revolve; but, as in our arrangement the clamp-holder does not revolve, but merely gives way to the motion of the trammel-cross, the prevention of the motion of the latter, as above described, admits of the holder remaining stationary when circles are to be cut.

What we claim as our invention, and desire to secure by Letters Patent, is—

1. The combination of the adjustable standard F, tranway E, pivots K K', with clamps J J', oscillatory clamp-holder H, and guide G, substantially as described.

2. In combination with the subject-matter of the above, the shears C C, substantially as described.

3. The combined elliptical and circular cutting-machine, constructed substantially as described.

In testimony that the above is our invention, we have hereunto set our hands and affixed our seals, this 28th day of January, 1871.

WILLIAM S. DEEDS. [L. S.]
JOHN P. BRADWAY. [L. S.]

Witnesses:

STEPHEN USTICK,
THOMAS J. BEWLEY.