

June 19, 1923.

1,459,140

L. P. CHICOINE

TRACK STRUCTURE

Filed Jan. 9, 1922

Fig-1.

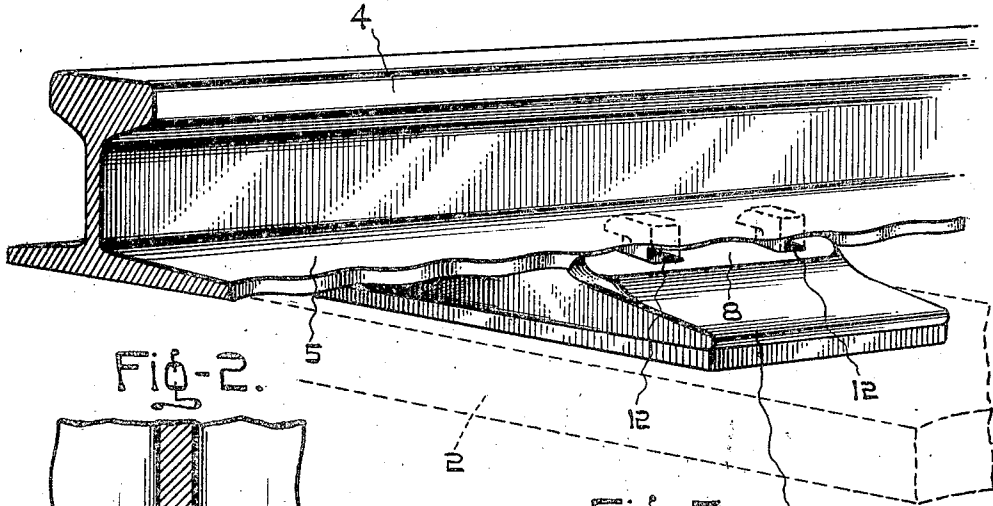

Fig-2.

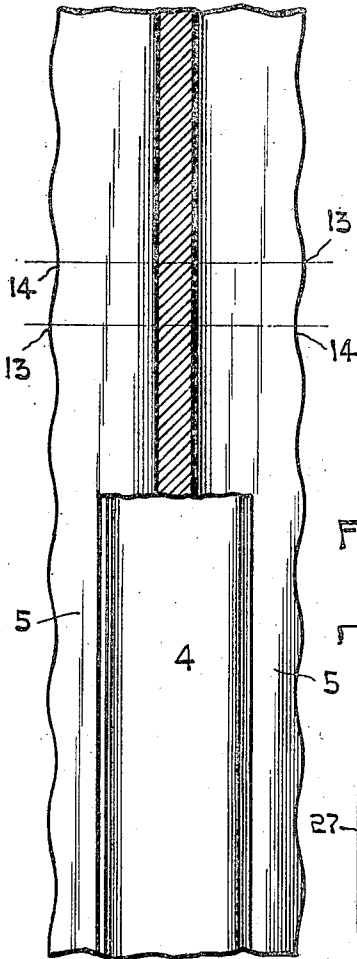
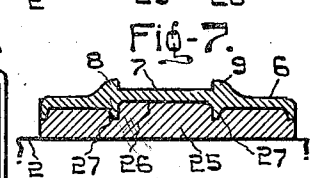
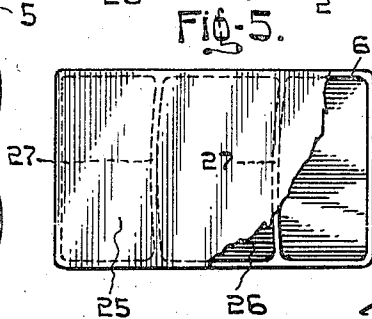
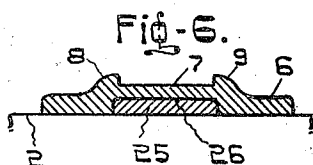
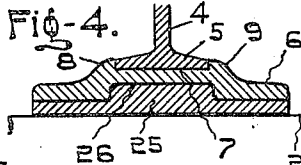
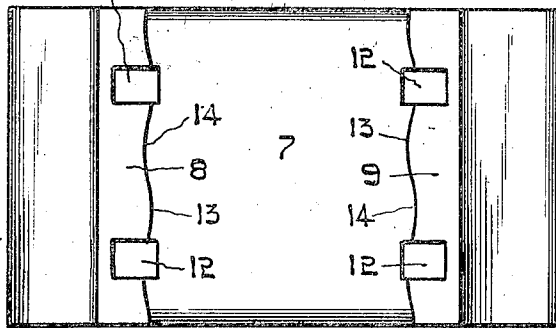

Fig-3.



Louis P. Chicoine,
Inventor.

William M. East
Attorney

Patented June 19, 1923.

1,459,140

UNITED STATES PATENT OFFICE.

LOUIS P. CHICOINE, OF VAUDREUIL, QUEBEC, CANADA.

TRACK STRUCTURE.

Application filed January 9, 1922. Serial No. 528,112.

To all whom it may concern:

Be it known that I, LOUIS P. CHICOINE, a resident of the town of Vaudreuil, Province of Quebec, Dominion of Canada, a subject of the King of Great Britain, have invented certain new and useful Improvements in Track Structures; and I do hereby declare that the following is a full, clear, and exact description thereof.

My invention relates to track structure for railroads and the like and has for its object to provide a structure of this type which will prevent longitudinal creeping of the rail; which will provide a cushion seat for the rail upon each of its supporting cross ties and thereby prolong the life of the rail particularly when subjected to heavy traffic; which will entirely eliminate or at least muffle the ring or rattle of the tie-plate usually produced by traffic; and which will elevate the rail above the ballast of the road-bed and thereby facilitate drainage and track work generally.

Briefly summarized the invention comprises a rail and tie-plate having interlocking surfaces and cushioning means interposed between the tie-plate and cross-tie, the underside of the tie-plate being constructed to accommodate the cushioning means and prevent displacement relatively to the tie-plate.

For full comprehension, however, of my invention reference must be had to the accompanying drawings in which similar reference characters indicate the same parts and wherein:

Figure 1 is a fragmentary perspective view of a track structure containing my invention

Figure 2 is a plan view partly in section of a rail constructed according to my invention;

Figure 3 is a plan view of a tie-plate constructed according to my invention;

Figure 4 is a transverse sectional view of the rail, tie plate, cushioning means and cross-tie;

Figure 5 is a plan view of the underside of the tie-plate with the cushioning means applied thereto; and

Figures 6 and 7 are detail sectional views illustrating modifications of the tie-plate and cushioning means.

Referring to the accompanying drawings which illustrate the preferred embodiment the supporting cross-tie is indicated at 2, the tie-plate at 6, the rail at 4 with base

flanges at 5 and the cushioning means which is interposed between the tie and tie plate at 25.

The top of the tie-plate presents a flat rail seat 7 which is flanked by shoulders 8 and 9. These shoulders extend the full width of the plate and are spaced apart a distance slightly greater than the width of the rail base to receive the same between them with their vertical faces bearing against the side edges of the base flanges, the rail and tie-plate being secured in such relative positions upon the tie by the usual spikes (indicated in dotted lines) which are driven through the holes 12 into the tie.

Heretofore the longitudinal creeping of the rails in service has caused the railroads considerable trouble and expense and although many rail-anchoring or anti-creeping devices have been put into service few have proved successful. It is, therefore, one object of the present invention to provide simple and efficient means embodied in the rail and tie plate which will prevent this creeping without adding materially to the cost of the same and without necessitating the use of extraneous rail-anchoring or anti-creeping devices.

To this end the side edges of the base flanges and the portions of the shoulders 8 and 9 contacting therewith are curved inwardly and outwardly relatively to the length of the rail to present sinuous or undulating surfaces having rises 13 and depressions or concavities 14, the rises on the flanges snugly fitting the concavities on the shoulders and vice versa so that the rail is locked against longitudinal movement in either direction.

The length of the undulations, that is to say, the distance from the crest of one rise to the crest of the adjoining rise should be such that each tie-plate may be placed in interlocking position with the rail without requiring an adjusting movement of the tie-plate of more than one and one-half inches.

In view of the many devices in use for various purposes which are designed to fit a rail base of standard width it is important in the present invention that a constant width be maintained throughout the length of the rail in order that those devices which it is desired to use in conjunction with the present invention may be used with the same facility as if applied to the standard rail with straight base flanges.

To this end the undulations on one side of the rail are in staggered relation with those on the other side, that is to say the concavities on one side are in transverse alignment with the rises on the other side (see Figures 2) so that a uniform measurement is secured throughout the rail length.

Another feature of the invention is the seat provided for the rail which not only acts as a cushion in dissipating the weight of the traffic thereon but also eliminates the rattle of the tie-plate which has proved one of the besetting difficulties in a great many tie-plates heretofore in use.

This improved rail seat is obtained by increasing the thickness of the tie-plate and inserting a creosoted wooden block therebetween and the tie. In order to prevent relative displacement between the tie plate and block the underside of the former is recessed as at 26 and the block shaped to snugly fit the same. The depth, shape and arrangement of the recesses may be varied to meet requirements. For instance for light traffic the tie-plate need only be provided with a middle recess and a comparatively light block positioned within the same, as indicated in Figure 6, while for heavier traffic the block may be made the full size of the plate and the latter recessed as indicated in Figure 7.

In order to cause the tie-plate to grip the block the sides of the recesses are curved or otherwise made irregular as at 27.

The increase in elevation of the rail above the ballast produced by such a seat facilitates both drainage and track work generally. For instance in the removal of a tie from beneath the rail, digging is eliminated by first removing the tie-plate, the space thereby provided enabling the tie to be pried up and pulled out.

What I claim is as follows:

1. In a railway road bed the combination with a tie, a tie plate mounted in fixed position upon the tie and a rail supported upon the tie plate, the side edges of the base flanges of the rail presenting undulating surfaces and the tie plate having corresponding undulating portions adapted to interlock with the undulating surfaces of the base flanges for the purpose of preventing longitudinal creeping of the rail, the underside of said tie plate having a recess therein and cushioning means located between the tie plate and tie and consisting of a fibre block adapted to extend into the recess.

2. In a railway road bed the combination with a tie, a tie plate mounted in fixed position upon the tie and a rail supported upon the tie plate the side edges of the base flanges of the rail presenting undulating surfaces and the tie plate having corresponding undulating portions adapted to interlock with the undulating surfaces of the base flanges for the purpose of preventing longitudinal creeping of the rail, the underside of said tie plate having a recess therein; and cushioning means between the tie plate and the tie said means consisting of a creosoted fibre block having a portion adapted to extend into and snugly fit said recess, the tie plate and block elevating the rail to a considerable degree above the ballast of the road bed.

In testimony whereof I have signed my name to this specification in the presence of two witnesses.

LOUIS P. CHICOINE.

Witnesses:

E. W. SAUVE,
G. FAVREAU.