

(12) **UK Patent Application** (19) **GB** (11) **2591380** (13) **A**

(43) Date of Reproduction by UK Office **28.07.2021**

(21) Application No: **2103305.5**

(22) Date of Filing: **20.09.2019**

Date Lodged: **10.03.2021**

(30) Priority Data:
(31) **2018703398** (32) **20.09.2018** (33) **MY**

(86) International Application Data:
PCT/MY2019/050060 En 20.09.2019

(87) International Publication Data:
WO2020/060388 En 26.03.2020

(51) INT CL:
F24H 1/20 (2006.01) **F24D 17/00** (2006.01)
F24H 9/00 (2006.01)

(56) Documents Cited:
WO 2016/011969 A1 **CN 201028754 Y**
CN 105180444 A **US 6943325 B2**

(58) Field of Search:
INT CL **F24D, F24H**
Other: **EPOQUE PATENW, Google Patents, Espacenet, AUSPAT**

(71) Applicant(s):
Thermo Integra SDN BHD
2A-B, Jalan Teknologi 3/5, Sunsuria Industrial Park,
Kota, Damansara, Petaling Jaya, Selangor 47810,
United Kingdom

(72) Inventor(s):
Tone Vei Tee
Chet Shen Vincent Ng
Weng Hong Lau

(74) Agent and/or Address for Service:
Handsome I.P. Ltd
27-28 Monmouth Street, BATH, BA1 2AP,
United Kingdom

(54) Title of the Invention: **Heating system for heating potable water**
Abstract Title: **Heating system for heating potable water**

(57) The present invention provides a heating system for heating potable water. Accordingly, the heating system (100) includes: (i) a boiler or storage tank (120a) with at least one liquid diffuser (130); and (ii) at least one heating element (140) for hot water production; characterised in that the liquid diffuser (130) comprises: a dome-shaped body (132); a plate (150) covering a base of the body (132) to enclose a hollow space between the body (132) and the plate (150), wherein the plate (150) has a central hole (152) and a plurality of arcuate cut-offs (154) along a circumference of the plate (150), forming a plurality of arcuate openings along intersection between the base of the body (132) and the plate (150). It should be noted that the liquid diffuser (130) of the present invention enables ambient or cold water from the inlet (200) to be uniformly introduced into the tank (120a) in a consistent downstream flow (220) of reduced velocity, such that formation of turbulence or forced convection flow within the tank (120a) can be minimised, and hence preserving smooth, divided layers (240) between the hot and cold water to form a stratified tank (120b).

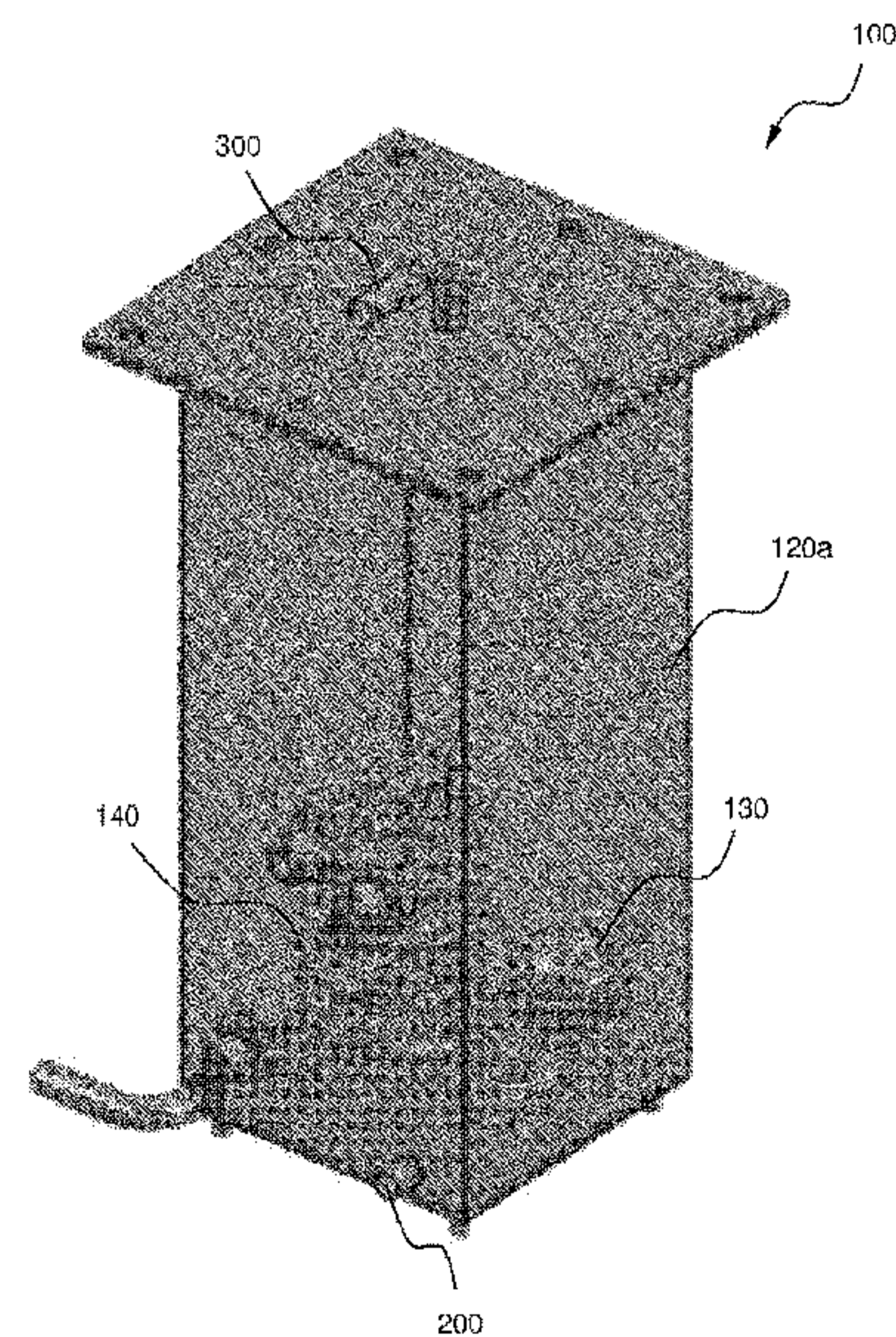

FIG. 1

GB 2591380 A