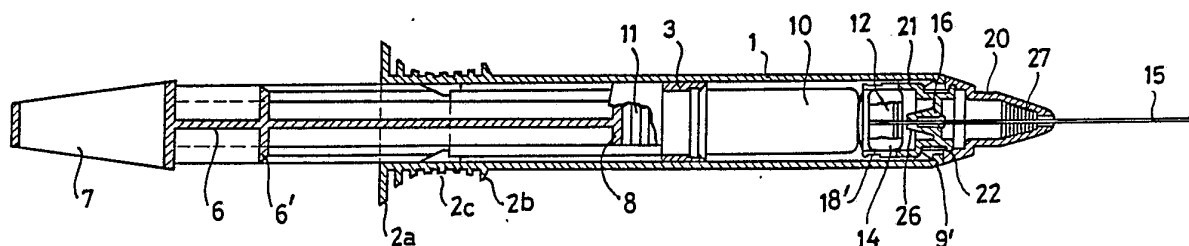




## INTERNATIONAL APPLICATION PUBLISHED UNDER THE PATENT COOPERATION TREATY (PCT)

<p>(51) International Patent Classification <sup>5</sup> : <b>A61M 5/32, 5/50</b></p>	<p><b>A1</b></p>	<p>(11) International Publication Number: <b>WO 90/01962</b> (43) International Publication Date: <b>8 March 1990 (08.03.90)</b></p>
<p>(21) International Application Number: PCT/NL89/00064 (22) International Filing Date: 23 August 1989 (23.08.89) (30) Priority data: 8802106 26 August 1988 (26.08.88) NL (71)(72) Applicant and Inventor: VAN DER HAAK, Abraham [NL/NL]; Dorpsstraat 14 00, NL-9537 TC Eesergroen (NL). (74) Agent: MOMMAERTS, J., H.; Exterpatent B.V., P.O. Box 90649, NL-2509 LP The Hague (NL). (81) Designated States: AU, DK, FI, JP, NO, US.</p>		<p><b>Published</b> <i>With international search report. Before the expiration of the time limit for amending the claims and to be republished in the event of the receipt of amendments.</i></p>

## (54) Title: SAFETY DEVICE FOR AN INJECTION SYRINGE NEEDLE



## (57) Abstract

A safety device for an injection syringe comprising an outer casing (1) defining an injection fluid space with a plunger (11) movable therein, said plunger being adapted to be coupled with a plunger rod (6) provided with an actuating knob or ring, while at the opposite end of said casing a needle foot (16) equipped with a hollow needle (15) may be fixed thereto in such a manner that the needle bore communicates with the interior of the fluid space, the needle foot (16) being movable inwards relative to the outer casing and adapted to be coupled to the piston in order that the needle may be retracted into said outer casing; the needle foot (16) and the casing (1) are provided with mutually engageable locking means for locking the needle foot (16) in its non-retracted position, and the plunger (11) or the plunger rod (6) and the needle (15) or the needle foot (16) are provided with means for coupling the plunger (11) or plunger rod (6) with the needle (15) or needle foot (16) and releasing the needle or needle foot lock after the plunger (11) has been completely pushed all the way into the injection fluid space (1, 10).

***FOR THE PURPOSES OF INFORMATION ONLY***

Codes used to identify States party to the PCT on the front pages of pamphlets publishing international applications under the PCT.

AT	Austria	ES	Spain	MG	Madagascar
AU	Australia	FI	Finland	ML	Mali
BB	Barbados	FR	France	MR	Mauritania
BE	Belgium	GA	Gabon	MW	Malawi
BF	Burkina Fasso	GB	United Kingdom	NL	Netherlands
BG	Bulgaria	HU	Hungary	NO	Norway
BJ	Benin	IT	Italy	RO	Romania
BR	Brazil	JP	Japan	SD	Sudan
CA	Canada	KP	Democratic People's Republic of Korea	SE	Sweden
CF	Central African Republic	KR	Republic of Korea	SN	Senegal
CG	Congo	LI	Liechtenstein	SU	Soviet Union
CH	Switzerland	LK	Sri Lanka	TD	Chad
CM	Cameroon	LU	Luxembourg	TG	Togo
DE	Germany, Federal Republic of	MC	Monaco	US	United States of America
DK	Denmark				

safety device for an injection syringe needle.

There is an increasing demand for injection syringes the needle of which can be covered after use in order to prevent injury by a used needle. On or in a needle which has been used for an injection there may be blood residues which, if another person pricks himself with the needle, may lead to infection with serious diseases, more particularly as yet incurable and even deadly diseases.

Replacing on a used needle for instance the sleeve used for packaging a needle is not a satisfactory solution, since injury may occur particularly in the course of fitting such a narrow sleeve, if the needle is stuck outside the opening. Since, moreover, the used needles, and often also the syringes, or at any rate the injection fluid containers therein and connected with the needle, are generally thrown away, care needs to be taken that the needles stay protected at all times, and thus also during processing of domestic waste. Apart from that, it is often required to prevent re-use of used disposable syringes by professional users as well as drug addicts.

Various solutions to this problem have already been proposed, such as sheaths which are slidable along the syringe, but these do not provide absolute security, because of, i.a., an insufficiently secure locking or fragility of the sheaths. In other solutions, the inside end of the needle, which connects the needle to the cylinder of the syringe, is connected to the plunger syringe after use so as to be retracted into the cylinder of the syringe after use. To this end, the inside end of the needle is first connected internally to the cylinder, for instance by means of a snap lock. However, connecting the plunger to the inside end of the needle, and sometimes also disengaging the inside end of the needle from the bottom of the cylinder, requires rotating and sliding movements in a certain order, which complicates the operation of the device although it is desirable to provide the possibility of rendering the needle harmless by a

-2-

manual movement which is as simple as possible. According to yet another published proposal, the inside end of the needle is connected to the cylinder by a line of weakness, which, subsequent to the coupling of the inside end to the plunger by means of a snap lock, must be broken in order to retract the needle into the cylinder, but it is difficult to produce such a line of weakness in a properly reproducible and reliable way, and besides, it is possible to move the needle outwards again.

10           The invention provides a syringe which does not have the said disadvantages. The syringe according to the invention comprises an outer casing defining an injection fluid space with a plunger movable therein, said plunger being adapted to be coupled with a plunger rod provided with an actuating knob or ring, while at the opposite end of said casing a needle foot equipped with a hollow needle may be fixed thereto in such a manner that the needle bore communicates with the interior of the fluid space, the needle foot being movable inwards relative to the outer casing and adapted to be coupled to the piston in order that the needle may be retracted into said outer casing, and is characterized in that the needle foot (16) and the casing (1) are provided with mutually engageable locking means for locking the needle foot (16) in its non-retracted position, and in that the plunger (11) or the plunger rod (6) and the needle (15) or the needle foot (16) are provided with means for coupling the plunger (11) or plunger rod (6) with the needle (15) or needle foot (16) and releasing the needle or needle foot lock after the plunger (11) has been completely pushed all the way into the injection fluid space (1,10).

The locking means used are external, while the syringe is also simple to produce and to operate.

Other advantageous embodiments are defined in the sub-claims.

35           The invention will now be elucidated in greater detail

with reference to the accompanying drawing, showing:

Fig. 1 a first embodiment of a safety syringe according to the invention in longitudinal section;

Fig. 2 a modification of the syringe of Fig. 1;

5 Figs. 3A and 3B a section corresponding to Fig. 1 and an end view, respectively, of a modified embodiment;

Figs. 4A and 4B a modification of the embodiment of Fig. 3 in two different conditions;

10 Figs. 5A and 5B sections through another embodiment of the safety syringe;

Fig. 6 a modification of the syringe of Fig. 5;

Figs. 7A and 7B sections through yet another embodiment of the safety syringe, and a view of a part thereof, respectively;

15 Fig. 8 another modification of the syringe of the invention combining features of the syringes of Figs. 4 and 7;

Figs. 8A..8D a modification of the syringe of Fig. 7 in different stages of the operation thereof; and

20 Fig. 9 another modification of the syringe of the invention combining features of the syringes of Figs. 4 and 7.

Fig. 1 shows a first embodiment of a syringe with a needle safety cover according to the invention, which is intended to contain closed glass containers filled with injection fluid, and which is particularly intended to be used only one. The syringe shown is more especially embodied as a syringe having a plunger which may be retracted after piercing the skin with the point of the needle, in order to establish whether a blood vessel has been hit, which will appear if blood is drawn in.

25

30

The syringe comprises an outer casing 1 having at least one window (not shown), and with two finger abutment edges 2a and 2b, between which the index and middle fingers are to be placed. Inside this casing, a sleeve 3 is fitted, which is

35

-4-

provided with longitudinal grooves 4, in each of which there is a projection 5 of the casing 1, which prevents the sleeve 3 from being removed from the casing. A plunger rod 6 is connected to this sleeve 3, which has, at its outer end, an actuation ring 7. The inner end of the plunger rod 6 has a coupling hook 8.

The other end of the casing 1 is provided with, for instance, three inwardly bent gripping springs 9. These fit grippingly around an injection fluid container 10 of the type which is usual in dental syringes. This container is closed at one end by a rubber stopper 11 which serves as a plunger, into which the hook 8 may be pushed, which then forms a push-pull connection with the stopper 11 in a known fashion. The other end is closed by a stopper 12 which may be pierced by the needle, which stopper is held by a metal cap 14 fixed in a waisted portion 13 of the container 10. A further part of the syringe is a needle 15, needles of various lengths and/or thicknesses being usable. Each needle is fixed in a needle foot 16, its inner end 17 projecting out of the foot 16, so that it can be pressed through the stopper 12 into the container 10. The foot 16 is provided with resilient claw members 18, which, when the needle foot is applied, engage around the cap 14 and in the waisted portion 13. The edge 19 of the foot 16 then abuts the end faces of the gripping springs 9, which prevent the needle foot from moving inwards.

To use the syringe, the sleeve 3 is retracted as far as possible, after which the container 10 is moved inwards in between the springs 9 until its end enters into the sleeve 3. By keeping the stopper 12 stationary, the hook 8 can be driven into the plunger 11 by pushing the ring 7 inwards. The plunger cannot move inwards, since the stopper 12 will not allow any fluid through. The needle foot is then fixed to the other end of the container 10, the needle end 17 penetrating the stopper 12. The syringe is then ready for use.

When the plunger is completely pressed in, and the

container 10 is empty, the sleeve 3 reaches the springs 9, which are pressed outwards by the sleeve 3, so that the inward lock of the needle foot 16 is terminated, while the needle end 17 may penetrate into the plunger 11. If the ring 7 is then pulled, the container 10 with the needle foot 16 connected thereto by the gripping members 18 is retracted. The needle 15 and its foot 16 then disappear entirely into the casing 1.

The container with the needle might be moved outwards again in order to be disposed of in, say, a secure collecting container or to be destroyed in a destruction apparatus. It would also be possible to place the casing 1 with its opening on a hard surface and then to bend the needle 15 onto itself and to throw away the container only then. It is then no longer possible to push the needle out of the container.

Preferably, however, the needle foot 16 is provided, as shown, with an additional cap 20 which fits around the container, and which is provided with gripping claws 21 which are fixed around the end portion of the casing 1 between the springs 9 behind lugs 22 provided thereon.

The front surface of this cap 20 has a passage 23 for the needle 15. Within this cap 20, there is a ring 24 which, in a manner known per se, is slidable transversely to the needle, so that, after retracting the needle from the ring, this ring can move downwards under its own weight, so that, when the needle is again pushed outwards, its point hits the ring, and if pressed further the needle is bent onto itself. Thus, the needle can be made harmless without any additional operation.

In the case of needles which are placed outside the centre line, such as are used for instance for extracting blood, it is also possible to use a cap which is provided with a corresponding hole for the passage of the needle, and which is rotated after retraction to provide an abutment surface for the needle point, while the cap may be provided

-6-

with a suitable locking device and may particularly be formed as a shiftable needle safety cover.

In their unused state, the cap 20 with the needle foot 16 are inside a protector sheath 25, which is closed in a sterile manner by a cover (not shown). After removal of this cover (in particular, after the pulling away of a sealing strip) the cap 20 can be fitted to the end of the casing, after which the sheath 25 is withdrawn from the cap 20.

Fig. 2 shows a preferred embodiment of the syringe of Fig. 1, and corresponding parts are indicated by the same reference numerals, as the case may be provided with primes to indicate a difference in shape. This syringe is shown with the plunger 11 already partially pushed inwards into the container 10, and the inner needle end 17 has already pierced the stopper 12.

Between the edges 2a and 2b ridges 2c are provided for improving the grip. The cross-shaped plunger rod 6 terminates in a flat disc 8' which is intended to contact the plunger 11 of the fluid container 10.

The container 10 is maintained at its outer end by resilient claws 5, which, after the plunger rod 6 has been completely pressed inwards, will be flexed outwards by a ring-shaped portion 6' of the rod 6 so as to allow the container 10 to be retracted afterwards, as will be explained below.

The end of the casing 1 at the needle side is substantially rigid, and is, at the inside provided with a shoulder 9' behind which resilient retaining the needle foot in a cover (not shown) for providing a sterile package of the needle. The edge 19 of the needle foot fits in a corresponding groove of the cap 20, and the resilient claws 18' of the needle foot 16 lie flatly against the container cap 14, so that a relative sliding movement is possible.

The needle foot 16 is provided with an inwardly directed projection 26 which, as shown, will contact the outer



-7-

surface of the stopper 12 which is, in fact, a rather elastic membrane. When pressing the plunger 11 inwards for the first time, this stopper 12 will be deformed inwardly by the projection 26, since the flow resistance in the hollow needle 15 is rather high. When the pressure on the plunger rod is relieved, the stopper 12 will return again towards its original position, so that the liquid in the hollow needle will be sucked back, and then it will appear whether blood is sucked in too, indicating that a blood vessel had been hit by the needle. In the case of the syringe of Fig. 1, this aspiration is obtained in the usual manner by retracting the eye 7.

After emptying the container 10, the extremity of the sleeve 3 will slide over the claws 18' of the needle foot, and a groove 18a will engage the claw ends so that the needle foot 16 is coupled with the sleeve 3, and will be retracted together with the sleeve for retracting the needle 15 inside the casing 1. The cap 20 is provided, on its inclined inner surface, with ripples 27. If, then, the plunger rod 6 is pressed inwards again, the tip of the needle will hit these ripples 17 when the needle is not completely straight, so that the needle will be wrinkled and, thus, destroyed. The needle can be fixed in the needle foot 16 in a slightly inclined manner so as to ensure that the needle will obtain the required inclination.

It will be clear that the same cap can be used in the case of Fig. 1, and also there the projection 26 may be provided.

Fig. 3 shows an alternative embodiment of the syringe according to the invention, intended especially for re-using the syringe casing. The outer casing 1 is, as is the case with syringes in common use, provided with a window 28 which allows the injection fluid container to be loaded sideways. On the opposite side, there is a smaller window 28', which allows the loaded container to be seen through the casing and which also facilitates the ejection of the used container.

The end face 29 at the needle end of the casing 1 is, in the embodiment shown, provided with a fitting groove 30 (see Fig. 2B) open towards the window 28 and which serves for fitting the needle foot 16 to the container 10. These  
5 containers 10 have a special shape, and form a coherent unit with the needle foot 16 and the needle 15. The needle is surrounded by a protecting sheath 27 attached to the needle foot 16, and the groove 30 has sharp edges 31 which, during  
10 fitting of the needle foot 16 in the groove 30, form an incision in the wall of the sheath 27, whereby the sheath 27 can be removed by, for instance, a rotational movement.

To facilitate the fitting of a container 10, the abutment edge 2b is slidable relative to the edge 2a, and is pressed outwards by a spring 32. Retraction of the edge 2b  
15 frees space for the insertion of the container 10 up to a shoulder 33. At the other end, a shoulder 33 prevents the container 10 from dropping out of the casing 1.

At the needle end, a stopper 12 is provided, which lies sealingly against the inside wall of the container 10, but is  
20 slidable therein with a certain friction. In the unused state, the stopper 12 is free from the inner end 17 of the needle. As, after the fitting of the container 10, the plunger rod 6 is pressed in, which is then connected by a hook 8 to the plunger 11 of the container 10, the pressure of  
25 the fluid will move the stopper 12, so that the inner end 17 of the needle will penetrate the thinner centre portion 12' of the stopper. The fluid can then be ejected through the needle 15.

A metal sleeve 34 with inwardly bent tabs or teeth 35  
30 is embedded in the plunger 11. The needle is guided through an opening 36 in the needle foot and is resiliently gripped. A collar 37 formed on the needle inner end 17 prevents the needle 15 from being pressed outwards during the pressing of the stopper 12.

35 After the plunger 11 is driven all the way in, the needle inner end 17 penetrates into the plunger and enters between the teeth 35 which engage grippingly around the said

needle end. If the plunger rod 6 is retracted, these teeth 35 grip the needle end 17 even more strongly, so that the needle 15 is drawn along and can slide in, with a certain friction, through the opening 36.

5           As soon as the needle 15 is drawn all the way into the container 10, the opening 36 closes at least partially due to the relaxation of the tensions caused by the resilient compression of the foot. If the plunger rod is then pushed inwards, the point of the needle abuts the inner wall of the  
10 foot 16, so that the needle 15 can be bent and made unusable.

          Instead of a hook 8 at the end of the plunger rod 6, a sleeve 38 can be formed on the end of the rod 6, as indicated in dashed lines, which can engage with the teeth 39  
15 projecting outwards from the sleeve 34 to form the required pulling connection. These teeth may also project inwards in order to engage the outside of the end of the rod 6.

          In this embodiment, it is also possible to use separate needles, the foot 16 of which is fitted to the end of the container 10, and in which case, instead of a shiftable  
20 stopper 12, a penetrable stopper 12 as shown in Fig. 1 may be used, other connections being possible as well.

          Fig. 4A and B show a modification of the syringe of Fig. 3, in which, again, corresponding elements have been indicated with the same reference numerals (as the use may be  
25 provided with primes to indicate a difference in shape). A casing 1 (not shown here) can be present as in the case of Fig. 3, but it is also possible to provide the outer wall of the container 10 with a transparent coating for protecting the glass wall thereof against breaking.

30           The plunger rod 6 shown in Fig. 4B (which may have again a cross-shaped section) is, instead of the hook 8, provided with a stud 8" which co-operates with inwardly directed hooks 39' of a sleeve 34' embedded in the plunger 11, and the rod 6 can be provided as a separate element to be  
35 coupled before use with the plunger 11.

          The end rim of the container 10 is normally bulged, as shown at 10a, and use is made thereof for strongly fitting on

-10-

this container 10 a cap 20 with a needle foot 16 of the same type as shown in Fig. 2. After placing said cap 20 on the container end (either just before use or in the factory), a groove in the cap 20 (also present in Fig. 2) snaps on said bulge 12a, and then the cap 20 is strongly fixed.

The stopper 12 has an elastic end rim 12a which, as soon as this stopper has been pressed towards the needle end 17 as shown in Fig. 4B, snaps behind the bulge 10a so as to keep the stopper 12 fixed in this position, but the rim 12a is so elastic that the connection can be broken again when the stopper 12 is to be retracted.

The needle end 17, after piercing the stopper 12, extends in the hollow part 12' thereof. The plunger 11 is provided, at its inner side, with a stud 35', e.g. a glass bead embedded in the plunger, which, as soon as it reaches the needle end 17, will bend aside the latter as shown in phantom lines in Fig. 4B. The needle bore will then be closed, so that, when retracting the plunger, the stopper will be pushed inwards by the atmospheric pressure as soon as a (relative) vacuum is created between the plunger 11 and the stopper 12, and also the needle foot 16 will be taken along since the needle end 17 has been bent.

As shown, the in phantom lines in Fig. 4B retracted needle 15 will have a slight inclination. This is caused by bending the needle end 17, since this needle is only supported by the relatively thin central portion 12' of the stopper 12. Moreover the contacting surfaces between the stopper 12 and the needle foot 16 can be given a slight inclination so as to support the inclination of the needle. The operation is, for the rest, the same as in the case of Fig. 2.

Fig. 5A and 5B show a different embodiment of the syringe according to the invention. The casing 1 is now also the injection fluid cylinder, which is provide with a plunger 11 and plunger rod 6; the other end of this casing including the atuating member of the plunger rod 6 is not shown for the

-11-

sake of clarity.

The needle end of the casing 1 is provided with an internal groove 40 with a circular outline adjoining on its outward side an edge 41 with a bevelled inner surface 42.

5 The syringe further comprises an injection needle 15 which is fixed in a needle foot 16. The needle foot consists of a pliable plastic material and has an outer edge 43 which fits in the groove 40 of the casing 1, but which, as appears from Fig. 3B, is formed slightly oval, so that its greatest  
10 diameter is approximately equal to the internal diameter of the groove 40. The foot 16 further comprises a sealing lip 44 which lies sealingly against the inner wall of the cylinder formed by the casing 1. The needle foot 16 is thus retained in the groove 40, while the sealing edge 44 provides a liquid  
15 tight fit against the cylinder wall.

At the inside of the needle foot 16, there is an inwardly projecting edge 45, which delimits a groove 46, the edge and groove, like the outer edge 43, having an oval  
20 shape. The plunger 11 has a slightly widened head portion 47 with a groove 48 behind it, both of which have a circular outline, it being possible to press the head portion 47 into the groove 46. Due to the elasticity of the material of which the foot 16 is made, the groove 46 is then made circular, so that locking of the foot to the head portion 47 takes place.  
25 The outer edge 43 of the needle foot is then also made circular, now in such a way, that it is now freed from the groove 40 at its rear end.

The operation of this syringe is as follows. After the plunger 11 is pressed all the way inwards during the  
30 injection of the injection fluid, its head 47 engages the groove 41 of the needle foot, which is then coupled to the plunger and freed from the groove 40. If the plunger 11 is then retracted, the needle foot will move inwards with the needle 15, so that the needle 15 is then effectively covered.

35 In this case also, an additional cap 20 as shown in

-12-

Fig. 1 and 2 may be applied, so that after retraction of the needle the latter can be bent onto itself by pushing the plunger outwards and thus making it unusable.

5 Instead of having the needle foot 16 deformable by the round plunger head portion 47, the wall of the outer casing 1 can be made resiliently deformable, at its needle foot and at least, so that it may be compressed between thumb and index finger in such a way that the edge 43 of the needle foot 16 is freed from the groove 40 which is thereby made oval. In 10 this case, it is also possible to use the sleeve 34 provided with gripping members 35 instead of the widened head portion 47, the needle 15 then having to project inwardly from the needle foot 16 so as to be gripped by the gripping member 35.

15 It is also possible to use, for filling the syringe, a special needle with a wider bore which, since it will never contact human body fluids, needs not to be destroyed. This filling needle can be provided with a simple foot which does not co-operate with the plunger head 47. After filling the syringe, this needle is replaced by an injection needle as 20 shown, which, after use, is retracted and destroyed in the manner described.

Fig. 6 shows a modification of the syringe of Fig. 5, in which parts corresponding with previously mentioned parts have been indicated by the same reference numerals (as the 25 case may be provided with primes to indicate a modified shape).

The casing 1 is provided with a narrower end portion 1b having elastic claws 41' with a bevelled end rim 42, allowing a needle foot 16 to be inserted therein and to be gripped by the claws 41', a rim 43' on the foot 16 then snapping in a 30 corresponding groove 40' in the inner wall of the casing end 1b. The needle foot 16 is, furthermore, provided with inwardly extending claws 18'.

The plunger head 47 is, now, also provided with claws 48' which, as shown in the upper half of Fig. 6, will grip 35 the claws 18' of the foot 16, the latter claws then being

-13-

bent inwardly so that the rim 43' is freed from the groove 40', and the foot can be retracted then together with the plunger 11.

Also in this case a filling needle with a modified foot  
5 can be used for filling the syringe, but it is also possible to use a needle foot of the kind as shown with a fitting adapted for mounting therein or thereon needles of different dimensions.

A cap 20 of the type shown in Figs. 1 and 2 can be used  
10 again for destroying the needle after retraction thereof into the casing 1, as described above.

Fig. 7 shows yet another embodiment of the syringe according to the present invention. This once again comprises an outer casing 1, which serves also as an injection fluid  
15 cylinder. Its bottom 49 is provided with a closure 50 which may be perforated. The needle 15 is normally inside the casing 1. Its needle foot 16 is now formed as an internal rod projecting through a cavity 51 of the plunger rod 6, the plunger rod further being provided with one or more grooves  
20 52 in order to connect an exterior actuator 53 with said needle foot 16. A passage 54 in the needle foot provides a connection between the inside of the casing 1 and the bore of the needle 15. The casing 1 may be pre-filled with injection fluid, but may also be sucked full after extension of the  
25 needle 15.

Prior to use, the actuator 53 is pushed downwards to press the needle 15 out through the closure 50. A lug 55 may then snap into an opening 56 in the actuator 53 so that the actuator is then locked to the casing to prevent retraction  
30 of the needle.

After the plunger 11 is pressed downwards, the needle can be retracted together with the plunger 11 by retracting the actuator 53 to make the needle harmless. Again, a cap 20 as shown in Fig. 1 and 2 may be used to enable the bending  
35 onto itself of the needle, while in addition a self-sealing

-14-

stopper as shown in Fig. 3 may be used.

It is also possible to provide the actuator knob 7 of the plunger rod 6 with a lug 57, which is bigger than the lug 55, and which widens a groove 58 located to one side of the snapping opening 56 (see Fig. 4B), so that the lug 55 is then freed from the snapping opening 56. In this way, an unequivocal locking between the actuator 53 and the knob 7 is achieved.

Also in the embodiment described with reference to Fig. 5, and in particular the one with a deformable outer wall, the possibility exists of initially providing the needle foot inside the casing and pushing it out prior to use to subsequently lock it, breaking the link with the plunger.

In Fig. 8 a modification of the syringe of Fig. 7 is shown, in which, again, corresponding parts have been indicated by the same reference numerals, as the case may be with primes to indicate a modification thereof.

In this case the rod-shaped needle foot 16 is provided, at its outer end, with a knob 53' lying inside the cavity 51 of the hollow plunger rod 6. Inside this cavity 51 a sleeve 59 with a shoulder 60 can slide on the foot 16. The shoulder 60 co-operates with an elastic latch 61 formed in the wall of the plunger rod 6. The outer diameter of the sleeve 59 is substantially the same as that of the knob 53'.

In the normal position shown in Fig. 8A with retracted needle 15, the latch 61 contacts the sleeve 59.

When pressing the plunger rod 6 downwards, the sleeve 59 will be taken along by the latch 61, and, as soon as the knob 53' engages the bottom of the hollow rod 6, also the needle foot 16 will be taken along so that the needle 15 is pushed outwards, as shown in Fig. 8B. It is also possible to construct the syringe so that already in the initial position shown in Fig. 8A the knob 53' contacts said bottom.

The forward end 47' of the needle foot 16 has a constriction 48' which is gripped then by resilient claws 45',



-15-

so that, then, the needle foot 16 and, thus, the needle 15, is maintained in its extended position.

The needle 15 is, then, inserted through the stopper 62 of an injection liquid container 63, as shown in Fig. 8C, whereafter the plunger rod 6 is retracted again for filling  
5 the syringe.

When pushing downwards the plunger rod 6, the plunger 11 presses the liquid outwards through the needle. Near the end of the downward stroke, see Fig. 8D, the sleeve 59 is  
10 taken along by the latch 61 as the shoulder 60 engages an edge 62 of this latch 61, and then the knob 53' slides along the latch to be gripped by an upper edge 63 of the latter. If, then, the plunger rod 6 is retracted again, the needle is completely retracted into the container 1, and can be des-  
15 troyed in the manner described before, e.g. by providing a sliding ring 24 in the bottom part 49, or by using a cap 20 as shown in Fig. 2.

The advantage of the construction shown in Fig. 8 is, that only one actuator, viz. the grip 7 of the plunger rod 6,  
20 is to be actuated and that it is not possible to actuate the latch 61 from the outside, so that, if the needle would not be destroyed, the syringe cannot be re-used.

Fig. 9 shows still another embodiment of the syringe of the invention, which can be considered as a combination of  
25 the syringes of Figs. 4 and 7. Corresponding parts thereof will, again, be indicated by corresponding reference numerals (with primes as the case may be). The description thereof will be restricted to the essential parts.

This syringe is intended for being filled with injection liquid in the factory, and the needle 15 extending from  
30 the container 1 is covered by a needle cap 25, the container 1 being closed by an end cap 20.

The needle foot 16 is, as in Fig. 7, a solid rod, e.g. made of glass, and the needle bore communicated with a hole  
35 54 in the lateral wall of said rod. The outer end of this rod

-16-

terminates in a knob 34"; claws 8" of the plunger rod 6 grip behind this knob 34". The inner end of the rod 16' is, as in the case of Fig. 8, provided with a knob 47' cooperating with a resilient seat 45' retaining said rod, and, moreover, providing a sealing so that the passage for the needle 15 in the cap 20 can be made larger.

As in the case of Fig. 4, a stopper 12 is provided, which is held by friction on the rod 16', as is also the plunger 11. When the plunger 11 is pushed inwards and slides, then, along the rod 16', the incompressible injection liquid will push also the stopper 54 along the rod 16' until it contacts the seat 45' of the cap 20, and the opening 54 is freed, so that the liquid will be pressed through the hollow needle. If the plunger rod 6 is retracted, the plunger 11 will be retracted too because of the vacuum created between the plunger and the plunger rod end, the latter closely fitting within the container 1, so that, again, blood will be sucked inwards if a blood vessel had been hit by the needle tip.

The hollow plunger rod 6 comprises, near its outer end, claws which will grip behind the knob 34" as soon as the plunger 11 has been completely shifted inwards. When retracting the plunger rod 6, the rod 16' will be retracted too, and the needle 15 is completely retracted within the container 1. It can be destroyed thereafter as in the case of the other embodiments.

It will be clear that the elements of the embodiments described above and shown in the drawings can be modified in many ways, and can be used, if necessary in adapted form, also in other embodiments.

CLAIMS

1. A safety device for an injection syringe comprising an outer casing defining an injection fluid space with a plunger movable therein, said plunger being adapted to be coupled with a plunger movable therein, said plunger being adapted to be coupled with a plunger rod provided with an actuating knob or ring, while at the opposite end of said casing a needle foot equipped with a hollow needle may be fixed thereto in such a manner that the needle bore communicates with the interior of the fluid space, the needle foot being movable inwards relative to the outer casing and adapted to be coupled to the piston in order that the needle may be retracted into said outer casing, **characterized** in that the needle foot (16) and the casing (1) are provided with mutually engageable locking means for locking the needle foot (16) in its non-retracted position, and in that the plunger (11) or the plunger rod (6) and the needle (15) or the needle foot (16) are provided with means for coupling the plunger (11) or plunger rod (6) with the needle (15) or needle foot (16) and releasing the needle or needle foot lock after the plunger (11) has been completely pushed all the way into the injection fluid space (1,10).

2. The safety device according to claim 1, **characterized** by said cap being provided with internal ripples (27) on an inclined inner surface adapted to retain the needle tip when the latter is being pushed outwards again after having been retracted within said cap (2).

3. The safety device according to claim 1 or 2, **characterized** in that the locking means consist of resilient gripping members (9,11',41) into which the needle foot (16) is placeable and lockable from the outside, the needle (15) then being made to sealingly communicate with the fluid space (1,10).

4. The safety device according to claim 3, adapted to receive in the outer casing an injection fluid container

-18-

which is closed at one end by a plunger which is adapted to be coupled to a plunger rod which is movable within the outer casing, the other end being closed by a stopper which can be pierced by the inner end of the needle after a needle foot is fitted, characterized in that the hook portions are formed by resilient tabs (9) bent inwards from the outer casing which engage around a fluid container (10) placed therein, in that the plunger rod (6) is connected to a sleeve (3) which is shiftable inside the outer casing (1) and along the fluid container (1) placed inside, the length of which is such that when the plunger (6) is pushed all the way in, it pushes said tabs (9) outwards to release the needle foot (16) from its lock, and in that the needle foot (16) is provided with locking claws (18) adapted to engage an appropriate recess (13) of the container (10).

5. The safety device according to claim 3, adapted to receive in the outer casing an injection fluid container which is closed at one end by a plunger which is adapted to be coupled to a plunger rod which is movable within the outer casing, the other end being closed by a stopper which can be pierced by the inner end of the needle after a needle foot is fitted, characterized in that the gripping members are resilient claws (18') on the needle foot (16) engaging a constricted portion of the container (10), and in that the plunger rod (6) is connected to a sleeve (3) which is shiftable inside the outer casing (1) and along the fluid container (1) placed inside, the length of which is such that when the plunger (6) is pushed all the way in, it pushes said claws (18') outwards to release the needle foot (16) from its lock.

6. The safety device of claim 5, characterized in that the plunger rod (6) comprises a flat end surface (8') sealingly fitting in said container (10) and is adapted to contact said plunger (11).

7. The safety device according to claim 3, intended to

-19-

receive in the outer casing an injection fluid container which is closed at one end by a plunger which is adapted to be coupled to a plunger rod which is movable within the outer casing, the other end being closed by a stopper which can be pierced by the inner end of a needle after a needle foot is fitted, **characterized** in that the pierceable stopper (12) is sealingly movable inside the container (10), in that the needle foot (16) is adapted to be sealingly placed in the end of the container (10) which projects beyond the stopper (12), the inner end (17) of the needle remaining free of the stopper (12) and being driven through said stopper (12) by the pressure of the fluid as the plunger (11) is pressed inwards for the first time.

8. The safety device according to claim 7, **characterized** in that a needle protection sheath (27) is fixed to the needle foot (16), and in that the plunger (11) is provided with inwardly projecting locking hooks (35) which, when the plunger is pressed all the way in, engage the inner end (17) of the needle so as to enable the needle (15), which is sealingly shiftable in the needle foot, to be retracted.

9. The safety device according to claim 8, **characterized** in that the locking means at the needle end of the outer casing (1) comprise an end wall (29) with a fitting groove (30) formed therein, the groove (30) being provided with sharp edges (31) for cutting through the wall of the sheath (27).

10. The safety device according to claim 7, **characterized** in that the plunger (11) is provided, at its inner side, with a stud (35') which is adapted to bend aside the inner end (17) of the needle (15) so as to close the latter's inner bore.

11. The safety device according to any one of claims 5..10, **characterized** in that the needle holder is provided with a projection (26) which is adapted to elastically deform the stopper (12) inwards so as to create a suction in said needle

-20-

(15) when the plunger (11) is slightly retracted and the stopper is allowed to regain its original shape.

12. The safety device according to claim 4, **characterized** in that the needle foot (16) is resiliently deformable and is provided with a sealing lip (44) which engages the inner wall of the fluid space (1) and is provided with a somewhat oval outer edge (43), in that the hook members are formed by a gripping edge (41) with an almost or wholly circular inner wall (40) engageable around the edge portions (43) of the needle foot (16) with the greatest diameter, in that there are means to free the needle foot (16) from the gripping edge (41) by resilient deformation, and in that the plunger (11) is provided with means for coupling it with the needle foot (16) (Fig. 3).

13. The safety device according to claim 11, **characterized** in that the surface of the plunger (11) which faces the needle foot (16) is provided with a coupling head portion (47) with a circular snapping edge (48), and in that the needle foot (16) is provided on its side facing the plunger (11) with a coupling cavity (46) corresponding therewith with a snapping groove corresponding with the snapping edge (48) of the head portion, which are oval, so that when the head portion (47) is placed in this cavity (46), the cavity (46) and thus also the needle foot (16) is made circular, so that the outer edge (43) is freed from the gripping edge.

14. The safety device according to claim 11, **characterized** in that the outer wall of the outer casing (1) is resiliently deformable, at its needle end at least, so that it may be pressed into an oval shape sufficient to free the needle foot (16) from the gripping edge (41).

15. The safety device according to claim 4, **characterized** in that the needle foot (16) is insertable from the outside into the sheath (1) or container (10) and is retained therein by means of a snap lock (40', 43'), and in that said foot (16) is provided at its inner end with resilient claws (18'),

the plunger being provided with claws (48') adapted to grip the former claws (18') and to bend these claws (18') so that the snap lock (40', 43') is released.

16. The safety device according to one of claims 6..14, **characterized** in that the plunger 11 is provided with locking hooks (35) which, when the plunger is pushed all the way in, can engage the needle inner end (17).

17. The safety device according to one of claims 1..3, with a needle foot which is shiftable inside the outer casing and a needle which is shiftable by a pierceable stopper in the bottom of the casing, **characterized** in that the needle foot is a rod (16) shiftable within a bore inside the plunger rod, which is provided with an actuator (53, 53') by which the needle (15) can be moved outwards through a pierceable stopper (50) present in the opening and can be retracted again, and in that the casing (1) and needle foot (16) are provided with locking means (55, 56; 45', 47) to lock the needle foot (16) relative to the outer casing (1).

18. The safety device according to claim 17, **characterized** in that the actuator (53) extends through a longitudinal groove (52) in the plunger rod (6) for being actuatable from the outside.

19. The safety device according to claim 18, **characterized** in that the plunger rod (6) or its actuation knob (7) is provided with release means (55, 56) for releasing the lock of the actuator (53) of the needle foot rod (6).

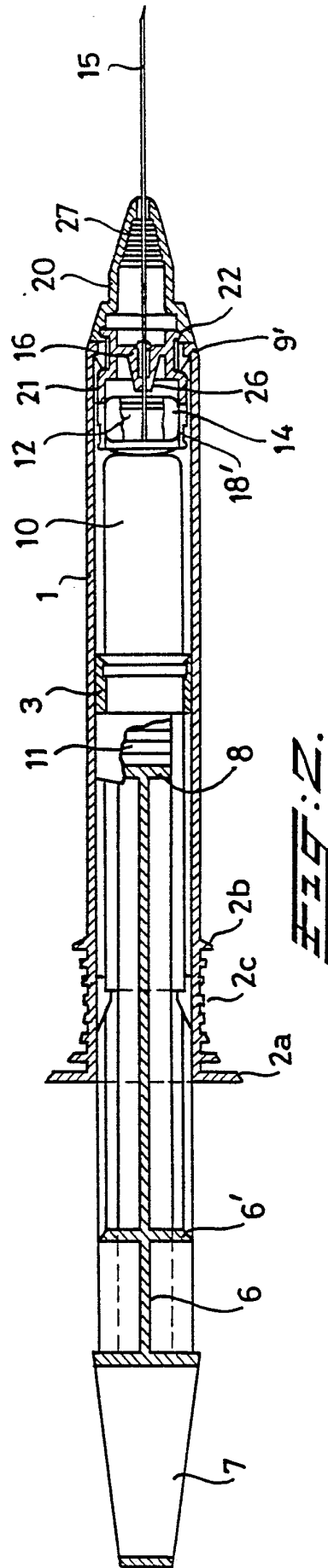
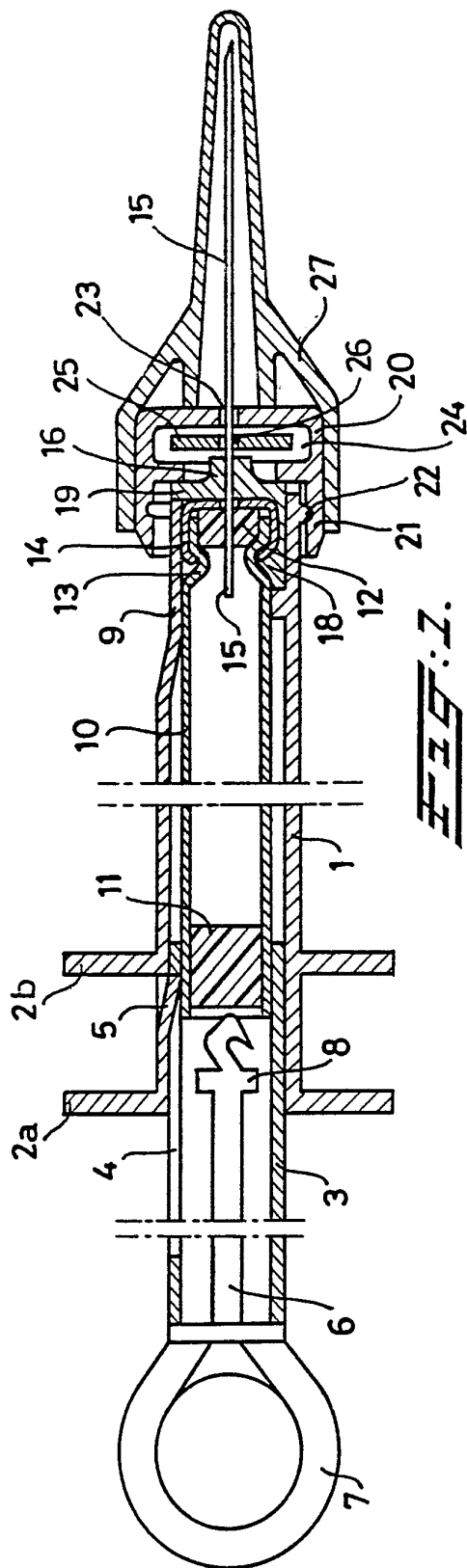
20. The safety device according to claim 17, **characterized** in that the needle foot (16) is provided with a knob (53') abutting an internal stop (7) of the plunger rod (6), and in that a sleeve (59) is slidable around the needle foot (16) and within the plunger rod (6), said sleeve having an external shoulder (60) co-operating with an elastic latch (61) in the plunger rod (6) so as to press the latter outwards and allowing said knob (53') to pass said latch (61) when pulling back said plunger rod (6) for aspirating injection liquid, said

-22-

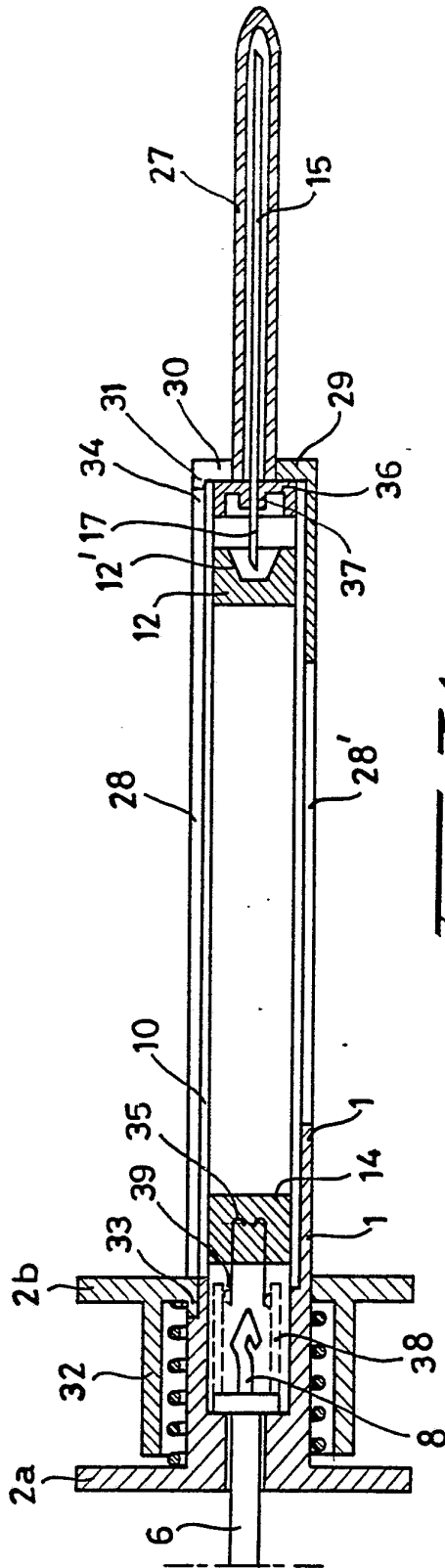
latch (6) gripping said shoulder (60) when pressing said plunger rod (6) inwards for expulsing said liquid, thus taking along said sleeve (59) so as to prevent it from blocking said latch (61), the latter then being adapted to  
5 take along said knob (53') at the nexte inward movement of said plunger rod (6).

21. The safety device according to claim 17, **characterized** in that a stopper (12) is slidable on said rod-shaped needle foot (16') and initially covers an aperture (54) in the wall  
10 of said needle (15) communicating with the bore thereof, the bottom part (20) of said container or casing (10, 1) being provided with an abutment (45') restricting the inward movement of said stopper (12), said abutment being also adapted to releasably grip the inner end (47') of said needle foot  
15 (16').

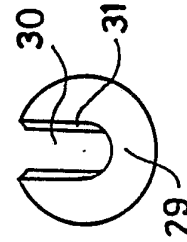




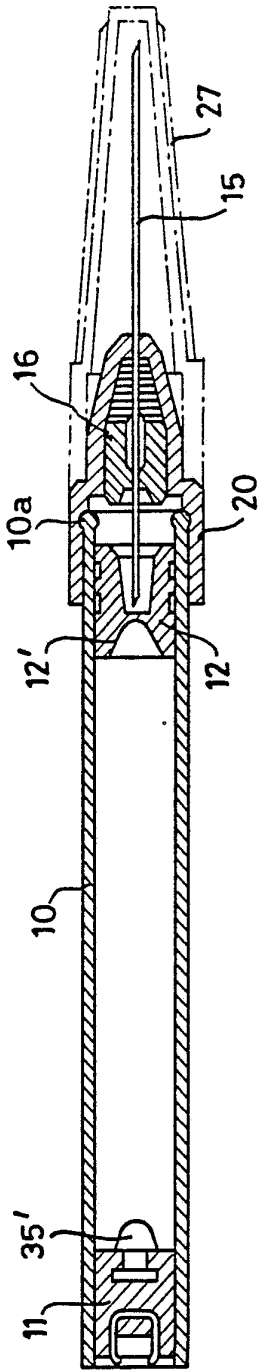
SUBSTITUTE SHEET



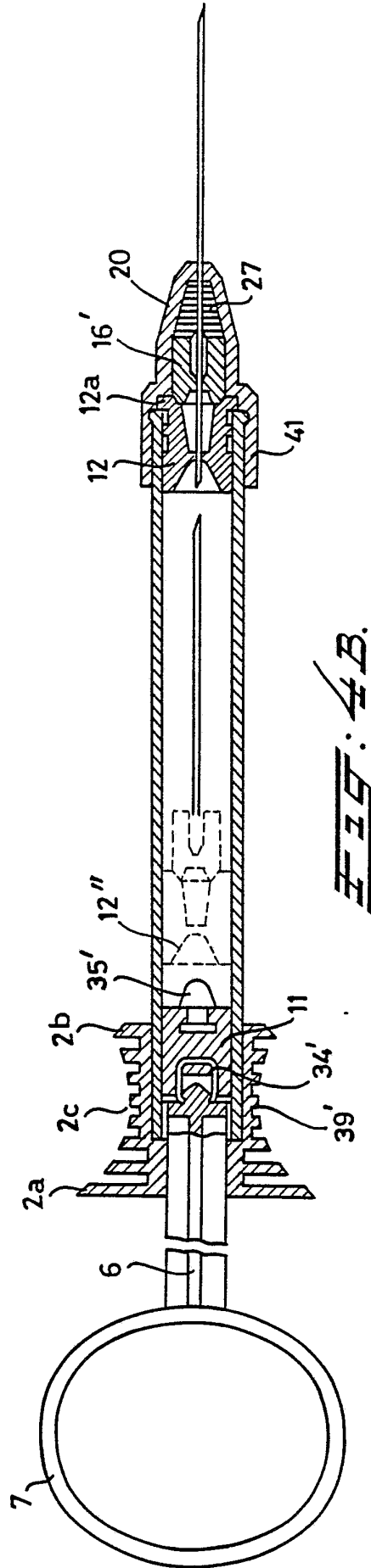
**FIG. 3A.**



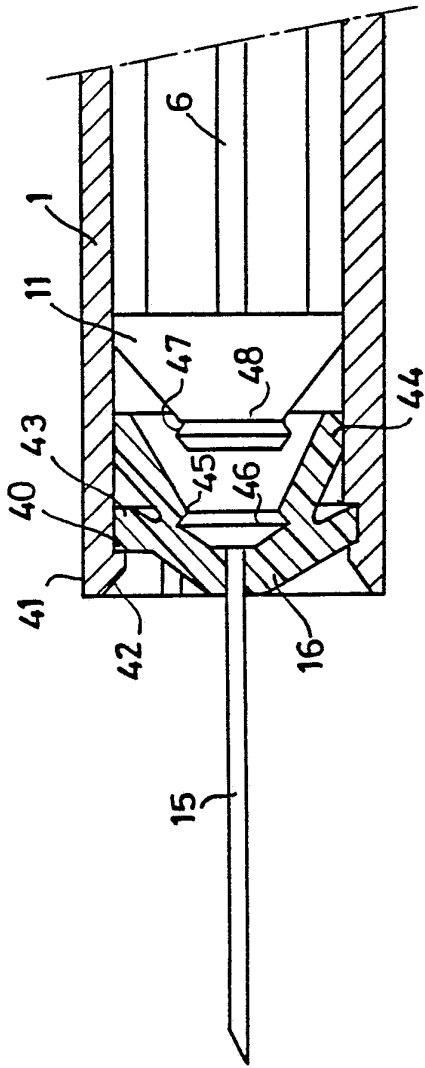
**FIG. 3B.**



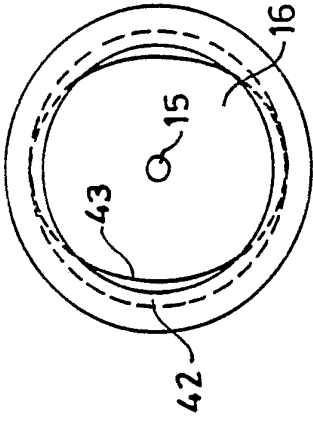
**FIG. 4A.**



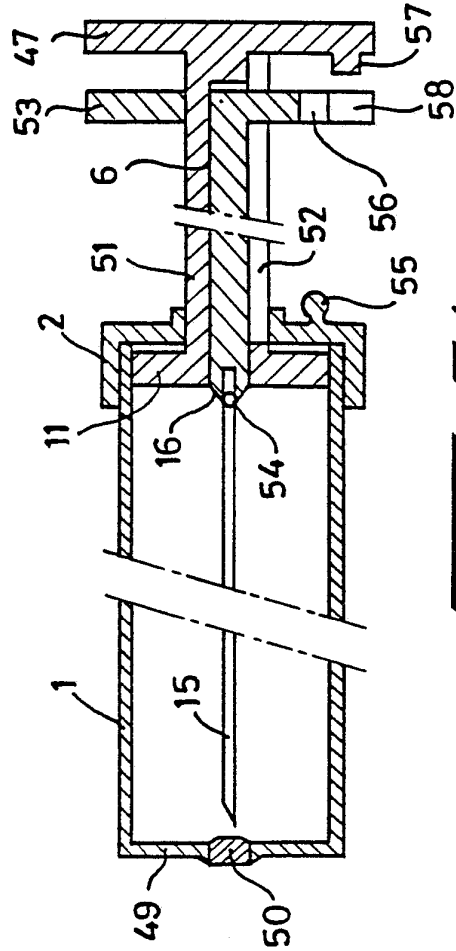
**FIG. 4B.**



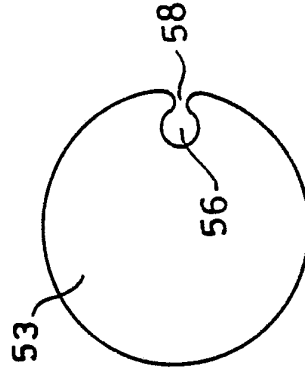
**FIG. 5A.**



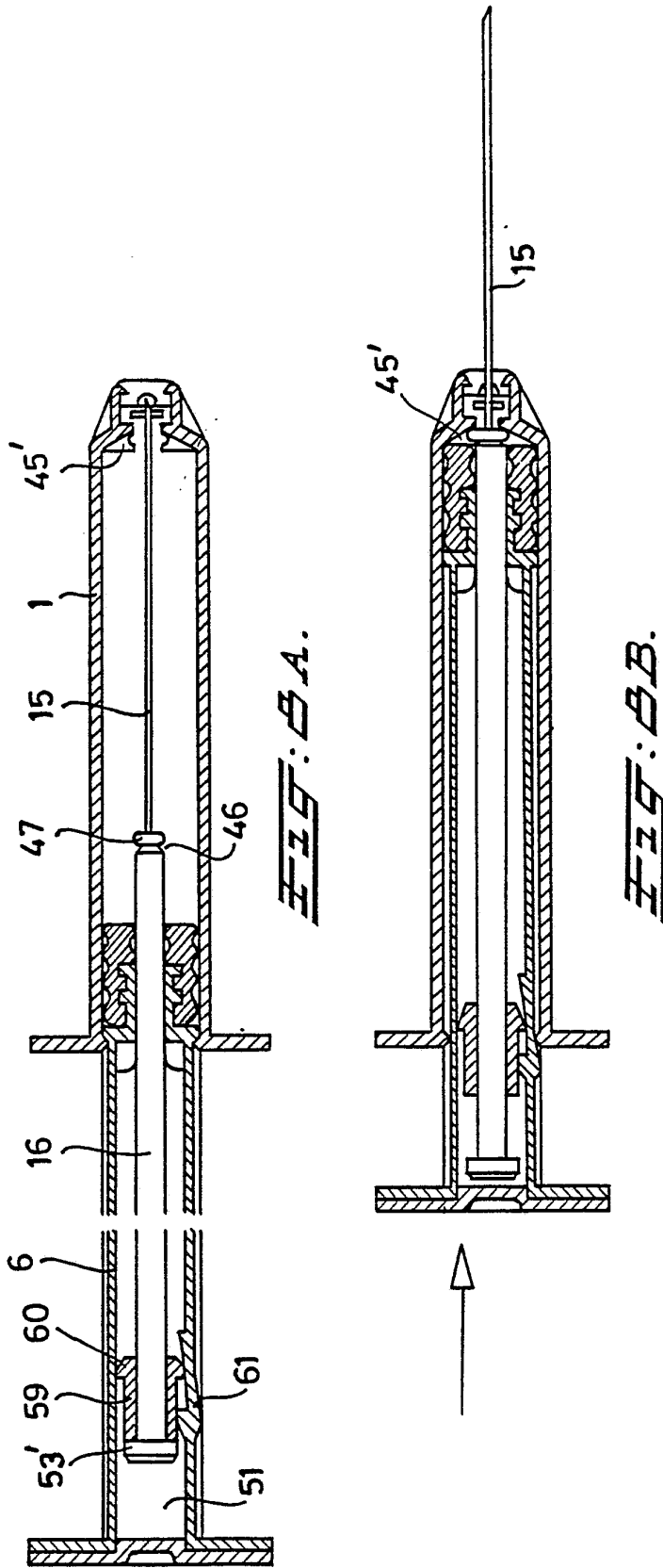
**FIG. 5B.**

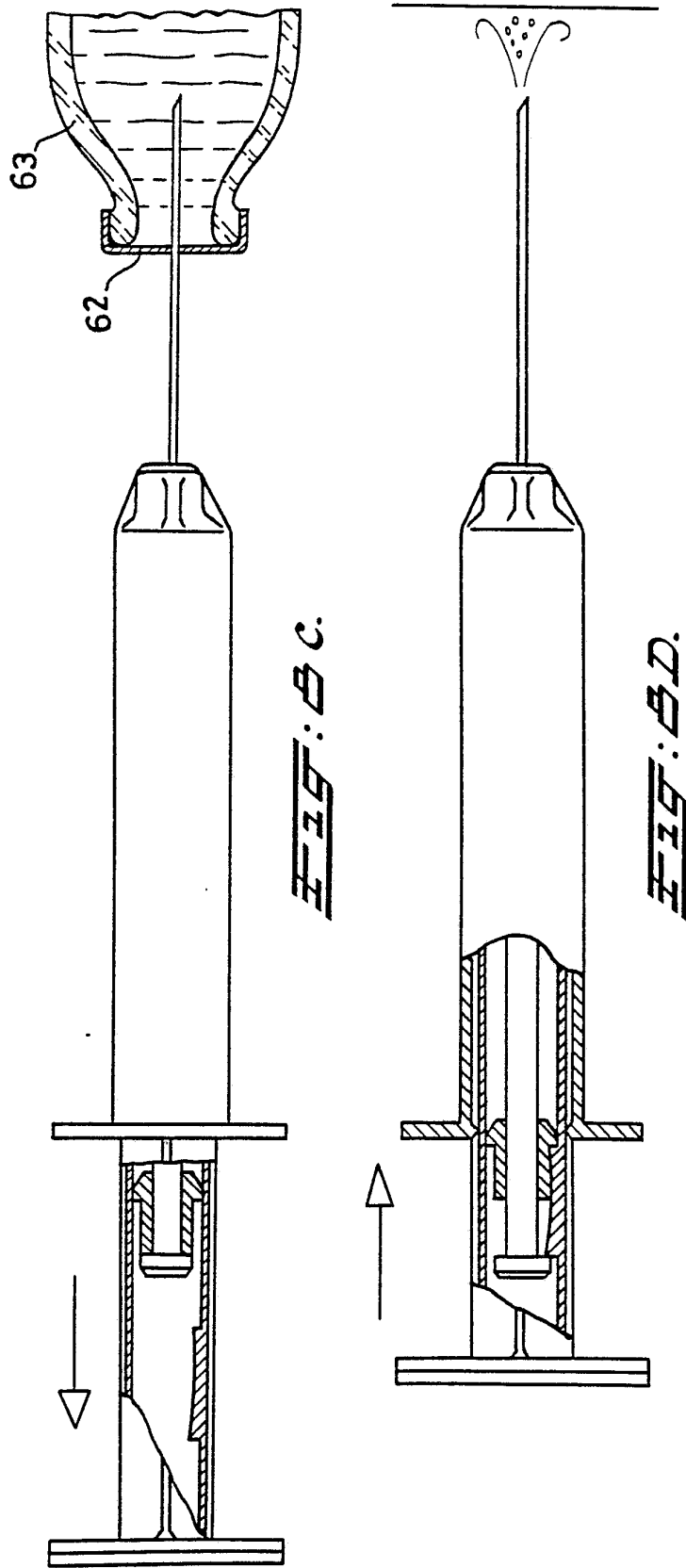


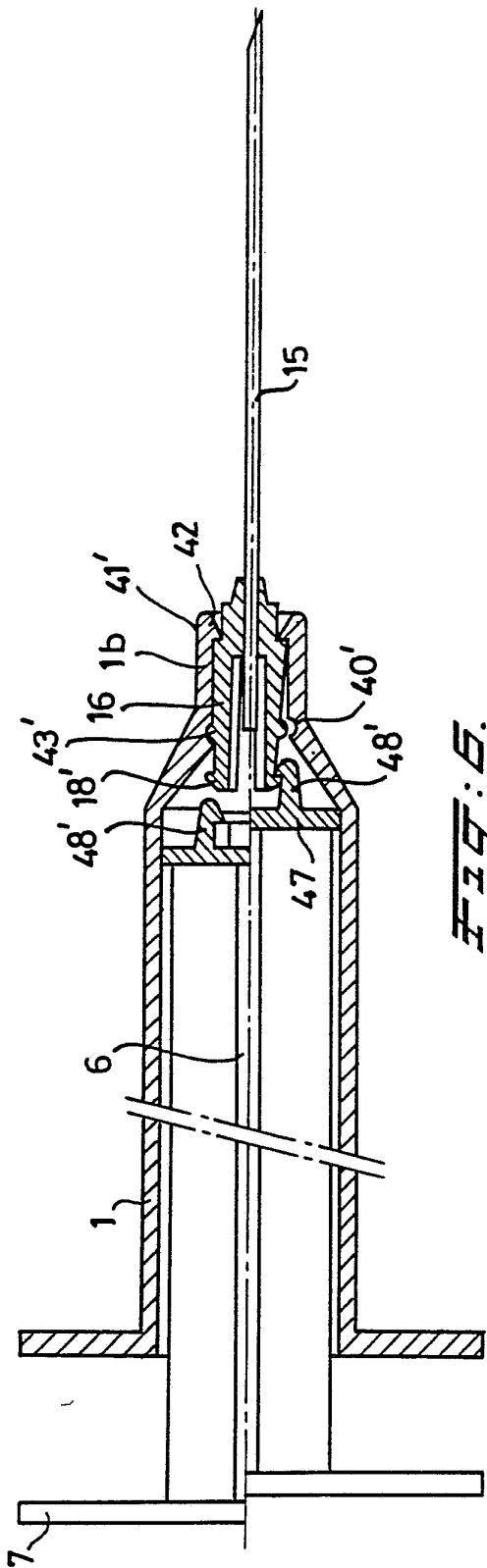
**FIG. 7A.**



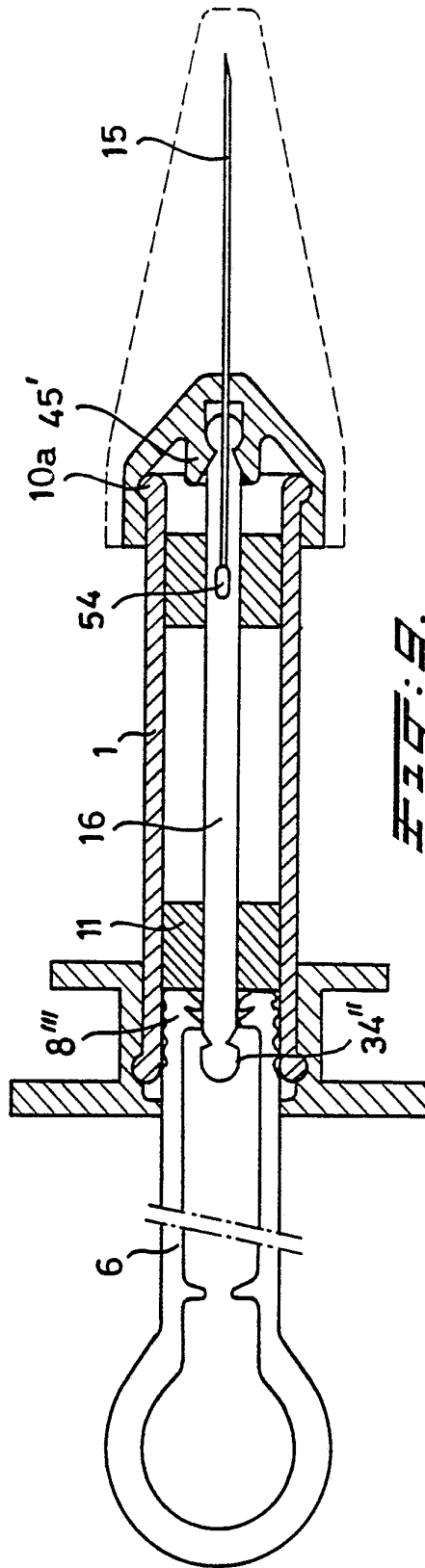
**FIG. 7B.**







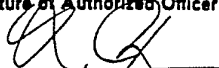
**FIG. 6.**



**FIG. 7.**

# INTERNATIONAL SEARCH REPORT

International Application No PCT/NL 89/00064

<b>I. CLASSIFICATION OF SUBJECT MATTER</b> (if several classification symbols apply, indicate all) <sup>6</sup>		
According to international Patent Classification (IPC) or to both National Classification and IPC		
IPC <sup>5</sup> : A 61 M 5/32, A 61 M 5/50		
<b>II. FIELDS SEARCHED</b>		
Minimum Documentation Searched <sup>7</sup>		
Classification System	Classification Symbols	
IPC <sup>5</sup>	A 61 M	
Documentation Searched other than Minimum Documentation to the Extent that such Documents are Included in the Fields Searched <sup>8</sup>		
<b>III. DOCUMENTS CONSIDERED TO BE RELEVANT</b> <sup>9</sup>		
Category <sup>9</sup>	Citation of Document, <sup>11</sup> with indication, where appropriate, of the relevant passages <sup>12</sup>	Relevant to Claim No. <sup>13</sup>
X	EP, A, 0276160 (E.R. SQUIBB & SONS INC.) 27 July 1988, see figures 1-14 --	1
X,L, P	EP, A, 0282097 (HABLEY MEDICAL TECHNOLOGY CORP.) 14 September 1988, see figure 4; claim 10 --	1,2
X	EP, A, 0278493 (HABLEY MEDICAL TECHNOLOGY CORP.) 17 August 1988, see figure 8; column 4, line 48 - column 5, line 16 --	1,3
A	EP, A, 0272035 (NATIONAL RESEARCH DEVELOP- MENT CORP.) 22 June 1988, see figures 1-9 ----	4-6
<p><sup>9</sup> Special categories of cited documents: <sup>10</sup></p> <p>"A" document defining the general state of the art which is not considered to be of particular relevance</p> <p>"E" earlier document but published on or after the international filing date</p> <p>"L" document which may throw doubts on priority claim(s) or which is cited to establish the publication date of another citation or other special reason (as specified)</p> <p>"O" document referring to an oral disclosure, use, exhibition or other means</p> <p>"P" document published prior to the international filing date but later than the priority date claimed</p> <p>"T" later document published after the international filing date or priority date and not in conflict with the application but cited to understand the principle or theory underlying the invention</p> <p>"X" document of particular relevance; the claimed invention cannot be considered novel or cannot be considered to involve an inventive step</p> <p>"Y" document of particular relevance; the claimed invention cannot be considered to involve an inventive step when the document is combined with one or more other such documents, such combination being obvious to a person skilled in the art.</p> <p>"&amp;" document member of the same patent family</p>		
<b>IV. CERTIFICATION</b>		
Date of the Actual Completion of the International Search	Date of Mailing of this International Search Report	
4th December 1989	10. 01. 90	
International Searching Authority	Signature of Authorized Officer	
EUROPEAN PATENT OFFICE	 L. ROSSI	



**ANNEX TO THE INTERNATIONAL SEARCH REPORT  
ON INTERNATIONAL PATENT APPLICATION NO.**

NL 8900064

SA 30544

This annex lists the patent family members relating to the patent documents cited in the above-mentioned international search report. The members are as contained in the European Patent Office EDP file on 22/12/89. The European Patent Office is in no way liable for these particulars which are merely given for the purpose of information.

Patent document cited in search report	Publication date	Patent family member(s)	Publication date
EP-A- 0276160	27-07-88	US-A- 4747829	31-05-88
		AU-A- 1025788	28-07-88
		JP-A- 63183072	28-07-88
EP-A- 0282097	14-09-88	US-A- 4826484	02-05-89
		US-A- 4770655	13-09-88
		AU-A- 1308888	22-09-88
		US-A- 4804370	14-02-89
EP-A- 0278493	17-08-88	US-A- 4710170	01-12-87
		AU-A- 1143688	18-08-88
EP-A- 0272035	22-06-88	AU-A- 8253887	16-06-88
		GB-A- 2200283	03-08-88
		JP-A- 63192453	09-08-88