



INTERNATIONAL APPLICATION PUBLISHED UNDER THE PATENT COOPERATION TREATY (PCT)

<p>(51) International Patent Classification <sup>6</sup> : H04L 25/06, 25/10, H03K 3/013, 5/22</p>	<p>A1</p>	<p>(11) International Publication Number: <b>WO 96/20552</b> (43) International Publication Date: 4 July 1996 (04.07.96)</p>
<p>(21) International Application Number: PCT/US95/16879 (22) International Filing Date: 28 December 1995 (28.12.95) (30) Priority Data: 08/365,222 28 December 1994 (28.12.94) US (71) Applicant: MAXIM INTEGRATED PRODUCTS, INC. [US/US]; 120 San Gabriel Drive, Sunnyvale, CA 94086 (US). (72) Inventor: ALLEN, Charles, M.; 869 Helena Drive, Sunnyvale, CA 94087 (US). (74) Agents: BLAKELY, Roger, W. et al.; Blakely, Sokoloff, Taylor &amp; Zafman, 7th floor, 12400 Wilshire Boulevard, Los Angeles, CA 90025-1026 (US).</p>	<p>(81) Designated States: JP, European patent (AT, BE, CH, DE, DK, ES, FR, GB, GR, IE, IT, LU, MC, NL, PT, SE).  <b>Published</b> <i>With international search report. Before the expiration of the time limit for amending the claims and to be republished in the event of the receipt of amendments.</i></p>	

(54) Title: METHOD AND APPARATUS FOR TRANSMITTING SIGNALS OVER A WIRE PAIR HAVING ACTIVITY DETECTION CAPABILITY

(57) Abstract

A method and apparatus for transmitting and receiving information over a network (20) that allows the detection of data transmission activity over a wire pair (50, 52, 100, 102) on the network. Within a computer system or other network device (10, 12, 14, 60, 90) a driver-receiver circuit (62, 66, 104, 105) along with an activity detector circuit (72-82, 115-120) are coupled to the wire pair such that when the wire pair is inactive, an Inactive signal (82, 112) is asserted, and the activity detector circuit will notify the network device that the network is not currently transmitting data. The activity detector includes a first voltage comparator (72, 114) coupled to a first differential threshold voltage generator (76, 118) and a second voltage comparator (74, 116) coupled to a second differential threshold voltage generator (78, 120). The absolute value of voltages generated by both differential threshold voltage generators is less than the minimum voltage levels required for a valid signal to be placed on the wire pair. The outputs of the first and second voltage comparators are coupled to an AND gate (80, 119) such that when the voltage differential across the wire pair is not sufficiently high to be a valid logic 1 or a valid logic 0, an Inactive signal (82, 112) is asserted. The Inactive signal, which indicates that the network is not currently transmitting data, is detected by the network device in which the driver-receiver circuit is incorporated.

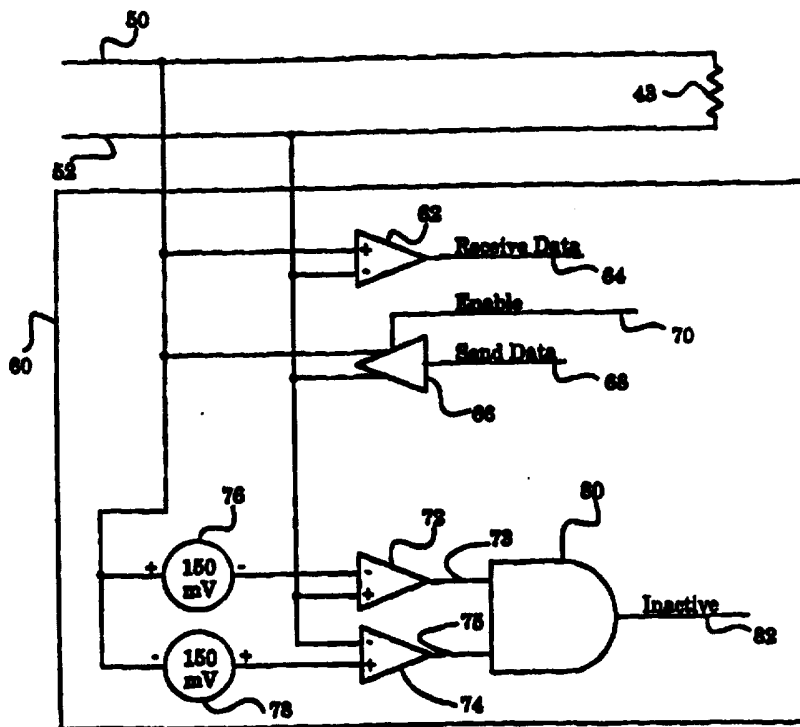

The Inactive signal, which indicates that the network is not currently transmitting data, is detected by the network device in which the driver-receiver circuit is incorporated.

**FOR THE PURPOSES OF INFORMATION ONLY**

Codes used to identify States party to the PCT on the front pages of pamphlets publishing international applications under the PCT.

AM	Armenia	GB	United Kingdom	MW	Malawi
AT	Austria	GE	Georgia	MX	Mexico
AU	Australia	GN	Guinea	NE	Niger
BB	Barbados	GR	Greece	NL	Netherlands
BE	Belgium	HU	Hungary	NO	Norway
BF	Burkina Faso	IE	Ireland	NZ	New Zealand
BG	Bulgaria	IT	Italy	PL	Poland
BJ	Benin	JP	Japan	PT	Portugal
BR	Brazil	KE	Kenya	RO	Romania
BY	Belarus	KG	Kyrgystan	RU	Russian Federation
CA	Canada	KP	Democratic People's Republic of Korea	SD	Sudan
CF	Central African Republic	KR	Republic of Korea	SE	Sweden
CG	Congo	KZ	Kazakhstan	SG	Singapore
CH	Switzerland	LI	Liechtenstein	SI	Slovenia
CI	Côte d'Ivoire	LK	Sri Lanka	SK	Slovakia
CM	Cameroon	LR	Liberia	SN	Senegal
CN	China	LT	Lithuania	SZ	Swaziland
CS	Czechoslovakia	LU	Luxembourg	TD	Chad
CZ	Czech Republic	LV	Latvia	TG	Togo
DE	Germany	MC	Monaco	TJ	Tajikistan
DK	Denmark	MD	Republic of Moldova	TT	Trinidad and Tobago
EE	Estonia	MG	Madagascar	UA	Ukraine
ES	Spain	ML	Mali	UG	Uganda
FI	Finland	MN	Mongolia	US	United States of America
FR	France	MR	Mauritania	UZ	Uzbekistan
GA	Gabon			VN	Viet Nam

METHOD AND APPARATUS FOR  
TRANSMITTING SIGNALS OVER A WIRE  
PAIR HAVING ACTIVITY DETECTION  
CAPABILITY

BACKGROUND OF THE INVENTION

1. Field of the Invention

The present invention relates generally to the field of computers and computer networks. More specifically, the present invention relates to a method and apparatus for transmitting and receiving data over a network having a circuit that detects whether data transmission activity is occurring over the network.

2. Related Art

Various standards for networking computer systems and other network devices through a wire pair are well known. One example of such a standard is the RS-485 interface standard. The RS-485 interface standard allows multiple network devices each having a driver-receiver circuit to be networked via a communication cable having at least one wire pair. In accordance with the RS-485 interface standard, the driver-receiver circuits are coupled in parallel to the wire pair such that a voltage differential placed on the wire pair can be detected simultaneously by each network device. Additionally, each network device can create a voltage differential across the wire pair at any time to transmit information to the other network devices.

Because the RS-485 interface standard allows each network device to transmit information over the wire pair at any time, some form of arbitration, scheduling or collision detection is needed to ensure that two network devices do not simultaneously attempt to drive the network. Otherwise, the conflict between the various drivers placing signals on the wire pair would result in unpredictable results. Conventional methods for preventing simultaneous attempts to transmit data over a network, which are often called "transmission collisions", include elaborate "token-passing" protocols. In these networks, each network device must wait until it is granted control of the wire pair before it may transmit data. An alternative method for preventing transmission collisions allows two or more network devices to simultaneously transmit information, but requires the receiving network devices to detect corrupt and faulty transmissions through the use of check sums, CRCs and other error detection schemes. Once a corrupt transmission is detected, an error signal is provided and the transmitting devices are required to retransmit the information.

These conventional transmission collision prevention methods have, however, several shortcomings. The use of a token passing protocol as described above requires each network device to track ownership of the network, and thus requires each network device to have extensive circuitry which adds to the overall complication and cost of the network. Additional circuitry is also required for the error detection scheme, and therefore this method also adds to the overall complication and cost of the network. In addition, the error detection scheme is inefficient because retransmits cause all transactions to be completed more slowly. This inefficiency is especially

noticeable when the wire pair is in use a substantial percentage of the time.

Accordingly, it is desirable to provide a method and apparatus for transmitting and receiving data over a network having a circuit that detects data communications activity over a wire pair on the network, whereby the circuit can be implemented easily and reliably.

#### BRIEF SUMMARY OF THE INVENTION

Based on the foregoing, a method and apparatus for transmitting and receiving information over a network that allows the detection of data transmission activity over a wire pair on the network is described. Within a computer system or other network device, a driver-receiver circuit along with an activity detector circuit are coupled to the wire pair such that when the wire pair is inactive, an inactive signal is asserted and the activity detector circuit will notify the network device that the network is not currently transmitting data. The activity detector includes a first voltage comparator coupled to a first differential threshold voltage generator and a second voltage comparator coupled to a second differential threshold voltage generator. The absolute value of voltages generated by both differential threshold voltage generators is less than the minimum voltage level required for a valid signal to be placed on the wire pair. The outputs of the first and second voltage comparators are coupled to an AND gate such that when the voltage differential across the wire pair is not sufficiently high to be a valid logic 1, or valid logic 0, an Inactive signal is asserted. The inactive signal which indicates that the

network is not currently transmitting data is detected by the network device in which the driver-receiver circuit is incorporated.

### BRIEF DESCRIPTION OF THE DRAWINGS

The objects, features and advantages of the present invention will become apparent from the following detailed description of the present invention in which:

**Figure 1** is an illustration of two computer systems and a printer networked over a network line in accordance with one embodiment of the invention.

**Figure 2** is a circuit diagram of the circuit used to interface a network device with a wire pair inside the network line configured in accordance with one embodiment of the invention.

**Figure 3** is a circuit diagram of the circuit used to interface a network device with a wire pair inside the network line configured in accordance with an alternate embodiment of the invention.

### DETAILED DESCRIPTION OF THE INVENTION

The present invention relates to a method and apparatus for communicating over a wire pair on a network that can detect whether the wire pair is available for transmitting data. In the following description, various circuits, voltage levels and signals, including those associated with the RS-485 interface standard, are set forth in detail. It will be obvious, however, to one skilled in the art that these details are not required to practice the present

invention. In other instances, various well known systems and circuits are shown in block form. This is done in order to avoid unnecessarily obscuring the disclosure of the present invention.

**Figure 1** is an illustration of two computer systems and a printer networked in accordance with one embodiment of the invention. Each of computer systems 10 and 12 and printer 14 are network devices that utilize an interface circuit (not shown in **Figure 1**) that allows them to transmit and receive data across network line 20. This transmission and reception of data allows files, information, and control signals to be exchanged between the various network devices.

The transmission of data across the network occurs over at least one wire pair located within network line 20. For the network to function properly, only one network device may transmit data at any one time over the wire pair contained in network line 20. When data is being transmitted it can be received and examined by the other network devices coupled to network line 20. The data is transmitted in serial manner which involves sending individual bits represented by voltage across the wire pair within network line 20 one at a time and one after the other.

**Figure 2** is a circuit diagram of an interface circuit 60 coupled to the wire pair in network line 20 (**Figure 1**), configured in accordance with a first embodiment of the invention. Interface circuit 60 is used by computer systems 10, 12 and printer 14 of **Figure 1** to receive and transmit data over the wire pair in network line 20. The wire pair comprised of signal lines 50 and 52 is terminated at either end by a resistor 43 (only one end shown). A typical value of the resistor 43 is 100  $\Omega$ . In accordance with the RS-485

interface standard, information on the network is represented by voltage differentials between lines 50 and 52 with a positive differential of greater than 1.0 volt representing a logic 0, and a negative differential of less than negative 1.0 volt representing a logic 1. The operation of the interface circuit 60 will be described in terms of its incorporation into computer system 10.

To allow computer system 10 to receive data, differential comparator 62 of interface circuit 60 detects the voltage differentials across lines 50 and 52 and asserts the appropriate logic level on data line 64 in response. The logic level on data line 64 is then received by computer system 10 which proceeds to process the information this logic level represents. For computer system 10 to transmit data using interface circuit 60, the desired logic level is placed on send data line 68 and enable line 70 is asserted. In response, driver circuit 66 generates a voltage differential across lines 50 and 52 corresponding to the logic level placed on send data line 68: greater than 1.0 volt for a logic 0, and less than negative 1.0 volt for a logic 1. When enable line 70 is not asserted, driver circuit 66 places a high impedance load across lines 50 and 52.

Simultaneous with this reading and writing activity, voltage comparators 72 and 74 of interface circuit 60 sense the voltage levels on signal lines 50 and 52. Voltage comparator 72 directly senses the voltage level signal line 52 via its noninverting input, and senses the voltage level on line 50 through voltage source 76 via its inverting input. Voltage source 76 is configured to cause voltage comparator 72 to assert logic high on line 73 when the voltage level on signal



line 50 is less than 150 mV above the voltage level on signal line 52. Voltage comparator 74 directly senses the voltage level on signal line 52 via its inverting input, and senses the voltage level on line 50 through voltage source 78 via its noninverting input. Voltage source 78 is configured to cause voltage comparator 74 to assert a logic high on line 75 when the voltage level signal line 52 is less than 150 mV above the voltage level on signal line 50. The result is that when the absolute value of the voltage differential between lines 50 and 52 is 150 mV or less, voltage comparators 72 and 74 both assert logic highs, causing AND gate 80 to assert an Inactive signal on Inactive line 82. Voltage comparator 72 and 74 each has a voltage gain suitable for creating a voltage level recognized by the logic level 1 voltage as specified for the selected AND gate 80.

By asserting the Inactive signal on line 82 when the absolute value of the voltage differential across signal lines 50 and 52 is less than 150 mV, interface circuit 60 indicates that data is presently being transmitted over the wire pair 50, 52. The RS-485 protocol, as well as many other communication protocols, require a voltage differential with an absolute value greater than 1.0 volt to be generated on a wire pair in order to indicate a valid logic level. Therefore, when the absolute value of the voltage differential across these signal lines is less than 150 mV, it can be inferred that no signal is being asserted. Thus, by providing a signal that indicates when such a condition occurs, interface circuit 60 indicates when the network is available for transmitting data.

The use of 150 mV offset voltage sources 76 and 78 ensures that false Inactive signals are not generated as

a result of improperly calibrated network devices coupled to the wire pair 50, 52. During operation of the network, such improperly calibrated interface circuit signals will assert a voltage level with an absolute value slightly less than the required 1.0 volt when actually attempting to assert a valid signal. The use of the 150 mV offsets creates a 850 mV differential between the point when a signal technically becomes invalid and the point where an Invalid signal is generated. This differential prevents a false Invalid from being asserted in response to these slightly miscalculated signals. Therefore, the use of the 150 mV voltage offsets reduces the likelihood of a false Inactive signal being asserted in response to improperly calibrated interface circuits being coupled to the network.

The use of the 150 mV voltage offsets also reduces the likelihood of false Invalid signals being asserted in response to slow logic transitions occurring across signal lines 50 and 52. During logic transitions the voltage levels asserted are invalid for a brief period of time. These invalid voltage levels may cause a false Inactive signals to be asserted if this period of time is sufficiently long to allow detection of the invalid voltage level by voltage comparators 72 and 74 to propagate through interface circuit 60 to Inactive line 82. By using the 150 mV offsets, the range at which a signal is detected as invalid is reduced 85 percent, from 2 volts to 0.3 volts, and therefore the period of time a false invalid reading can propagate through interface circuit 60 is also reduced. Thus, the use of 150 mV voltage offsets also reduces the likelihood of false Inactive signals being asserting in response to slow logic transitions.

Computer system 10 and other network devices incorporating the use of interface circuit 60 can utilize the Inactive signal provided on Inactive line 82 to minimize the number of transmission collisions that occur over the network, and thereby increase the network's overall efficiency. A network device such as computer system 10 incorporating the use of interface circuit 60 need only monitor the state of the Inactive line 82, and refrain from transmitting data until the Inactive signal is asserted. This will reduce or eliminate any collisions that occur over the network thus increasing the efficiency of data transmission. Additionally, interface circuit 60 is relatively simple and easy to implement and therefore provides this improved network efficiency at a low cost.

**Figure 3** is a circuit diagram illustrating an alternate embodiment of the interface circuit 90 of the present embodiment coupled to a wire pair 100, 102. The wire pair is composed of a wire 100 coupled through a resistor 101 to ground, and a wire 102 coupled directly to ground. A typical value of the resistor 101 is 12 kohms. During operation, information is received by input buffer circuit 104 which detects the voltage level on line 100 and asserts a corresponding logic signal on receive Data 106 in response. Data is driven out by driver 105 which receives data to be transmitted on send line 110, and generates a voltage differential with respect to ground on line 100 when enable line 111 is asserted by computer system 10. Line 102 is also coupled to ground inside transmitter receiver circuit 90.

During operation, voltage comparator 114 and offset voltage source 118 detect when the voltage level on line 100 is greater than positive 300 mV, and asserts a logic

low on line 115 in response. Voltage comparator 116 and offset voltage source 120 detect when the voltage level on line 100 is greater than negative 300 mV, and asserts a logic low on line 117 in response. Thus, when the absolute value of the voltage level on line 100 is greater than 300 mV, either voltage comparator 114 or voltage comparator 116 will assert a logic low causing AND gate 119 to assert a logic low on Inactive line 112. This logic low indicates that data is currently being transmitted on lines 100 and 102. If, however, the absolute value of the voltage level on line 100 is less than 300 mV, voltage comparators 114 and 116 both assert logic highs on lines 115 and 117 respectively, causing AND gate 119 to assert a logic high Inactive signal on Inactive line 112, indicating the network is available for transmitting data.

The essential difference between interface circuit 90 of **Figure 3** and interface circuit 60 of **Figure 2** is that the voltage differentials used to indicate logic levels in interface circuit 90 are generated with respect to ground, as opposed to the "floating" differential used in interface circuit 60. In both embodiments, computer system 10 can use the Invalid signal generated on Inactive line 82 or 112 to refrain from transmitting data until network is available and thereby increase the overall efficiency of the network. Also, like interface circuit 60, interface circuit 90 is relatively inexpensive to implement. By configuring interface circuit 90 to measure the voltage level generated with respect to ground, however, this second embodiment is compatible with single-ended communication standards such as the well known EIA/TIA-232E and EIA/TIA-562 communication standards which generate voltage levels with respect to ground rather than with respect to another signal line.

Thus, a method and apparatus for transmitting and receiving data over a network line having a single wire pair that prevents transmission collisions, and that can be implemented reliably and at a low cost is described. To those skilled in the art, alternative embodiments of the invention will be readily apparent. The example provided is merely for illustrative purposes and should not be taken as limiting the scope of the invention.

**CLAIMS:**

What is claimed is:

1. A circuit for detecting data communications activity over a wire pair on a network to which said circuit is coupled, said circuit comprising:

a detection circuit for detecting a voltage differential across said wire pair representative of an Invalid logic level; and

an output circuit for providing a network Inactive signal responsive to the output of the detection circuit.

2. The circuit as set forth in Claim 1, wherein said signal detection circuit comprises:

first voltage comparator circuit for detecting said voltage differential that is greater than a first threshold value; and

second voltage comparator circuit for detecting said voltage differential that is less than a second threshold value.

3. The circuit set forth in Claim 1, wherein said signal detection circuit comprises:

a first voltage comparator, coupled to said wire pair, for providing a first Invalid signal; and

a second voltage comparator, coupled to said wire pair, for providing a second Invalid signal.

4. The circuit set forth in Claim 3, further comprising:

driver circuit for generating said voltage differential across said wire pair; and

receiver circuit for generating an internal logic signal in response to said voltage differential across said wire pair.

5. The circuit set forth in Claim 3, further comprising:

first offset voltage source for generating a first voltage offset coupled between said first voltage comparator means and said wire pair; and

second offset voltage source for generating a second voltage offset coupled between said second voltage comparator means and said wire pair.

6. The circuit as set forth in Claim 5, wherein said output circuit comprises:

AND gate for generating said network inactive signal in response to said first Invalid signal and said second Invalid signal.

7. The circuit as set forth in Claim 5, wherein said first threshold value is less than said second threshold value.

8. The circuit as set forth in Claim 5, wherein said first threshold value is -150 mV; and said second threshold value is 150 mV.

9. A circuit for detecting data communications activity over a wire pair on a network to which said circuit is coupled, said circuit comprising:

means for detecting a voltage differential across said wire pair representative of an Invalid logic level; and

means for providing a network inactive signal responsive to the output of said means for detecting.

10. The circuit as set forth in Claim 9, wherein said means for detecting comprises:

first means for detecting said voltage differential that is greater than a first threshold value; and

second means for detecting said voltage differential that is less than a second threshold value.

11. The circuit set forth in Claim 9, wherein said means for detecting comprises:

first voltage comparator means, coupled to said wire pair, for providing a first Invalid signal; and

second voltage comparator means, coupled to said wire pair, for providing a second Invalid signal.

12. The circuit set forth in Claim 11, further comprising:

means for generating said voltage differential across said wire pair in response to a first internal logic signal; and



means for generating a second internal logic signal in response to said voltage differential across said wire pair.

13. The circuit set forth in Claim 11, further comprising:

means for generating a first voltage offset coupled between said first voltage comparator means and said wire pair; and

means for generating a second voltage offset coupled between said second voltage comparator means and said wire pair.

14. The circuit as set forth in Claim 13, wherein said means for asserting comprises:

AND gate means for generating said output inactive signal in response to said first Invalid signal and said second Invalid signal.

15. The circuit as set forth in Claim 13, wherein said first threshold value is less than said second threshold value.

16. The circuit as set forth in Claim 13, wherein said first threshold value is -150 mV; and said second threshold value is 150 mV.

17. A method for detecting data communications activity over a wire pair on a network to which said circuit is coupled, said method comprising the steps of:

a) detecting a voltage differential across said wire pair representative of an Invalid logic level; and

b) providing a network Inactive signal responsive to the result of said detection step.

18. The method as set forth in Claim 17, wherein step a) comprises the steps of:

detecting said voltage differential that is greater than a first threshold value; and

detecting said voltage differential that is less than a second threshold value.

19. The circuit set forth in Claim 17, wherein step a) comprises the steps of:

providing a first Invalid signal in response to said voltage differential that is less than a first value; and

providing a second Invalid signal in response to said voltage that is greater than a second value.

20. The circuit set forth in Claim 19, further comprising the steps of:

generating said voltage differential across said wire pair; and

generating an internal logic signal in response to said voltage differential across said wire pair.

21. The circuit set forth in Claim 19, further comprising the steps of:

generating a first voltage offset between said wire pair and a first voltage comparator; and

generating a second voltage offset between a second voltage comparator means and said wire pair.

22. The circuit as set forth in Claim 21, wherein step b) comprises the steps of:

generating said network inactive signal in response to said first Invalid signal and said second Invalid signal.

23. The circuit as set forth in Claim 21, wherein said first threshold value is less than said second threshold value.

24. The circuit as set forth in Claim 21, wherein said first threshold value is -150 mV; and said second threshold value is 150 mV.

25. A device coupled to a network, said device having a circuit for detecting data communications activity on said network, said circuit comprising:

a) detection circuit for detecting if said network is currently transmitting data; and

b) an output circuit for providing a network signal responsive to the output of the detection circuit.

26. The device as set forth in Claim 25, wherein said signal detection circuit comprises:

first voltage comparator circuit for detecting said voltage differential that is greater than a first threshold value; and

second voltage comparator circuit for detecting said voltage differential that is less than a second threshold value.

27. The circuit set forth in Claim 25, wherein said signal detection circuit comprises:

a first voltage comparator, coupled to said wire pair, for providing a first Invalid signal; and

a second voltage comparator, coupled to said wire pair, for providing a second Invalid signal.

28. The circuit set forth in Claim 27, further comprising:

driver circuit for generating said voltage differential across said wire pair; and

receiver circuit for generating an internal logic signal in response to said voltage differential across said wire pair.

29. The circuit set forth in Claim 27, further comprising:

first offset voltage source for generating a first voltage offset coupled between said first voltage comparator means and said wire pair; and

second offset voltage source for generating a second voltage offset coupled between said second voltage comparator means and said wire pair.

30. The circuit as set forth in Claim 29, wherein said output circuit comprises:

AND gate for generating said network inactive signal in response to said first Invalid signal and said second Invalid signal.

31. The circuit as set forth in Claim 29, wherein said first threshold value is less than said second threshold value.

32. The circuit as set forth in Claim 29, wherein said first threshold value is -150 mV; and said second threshold value is 150 mV.

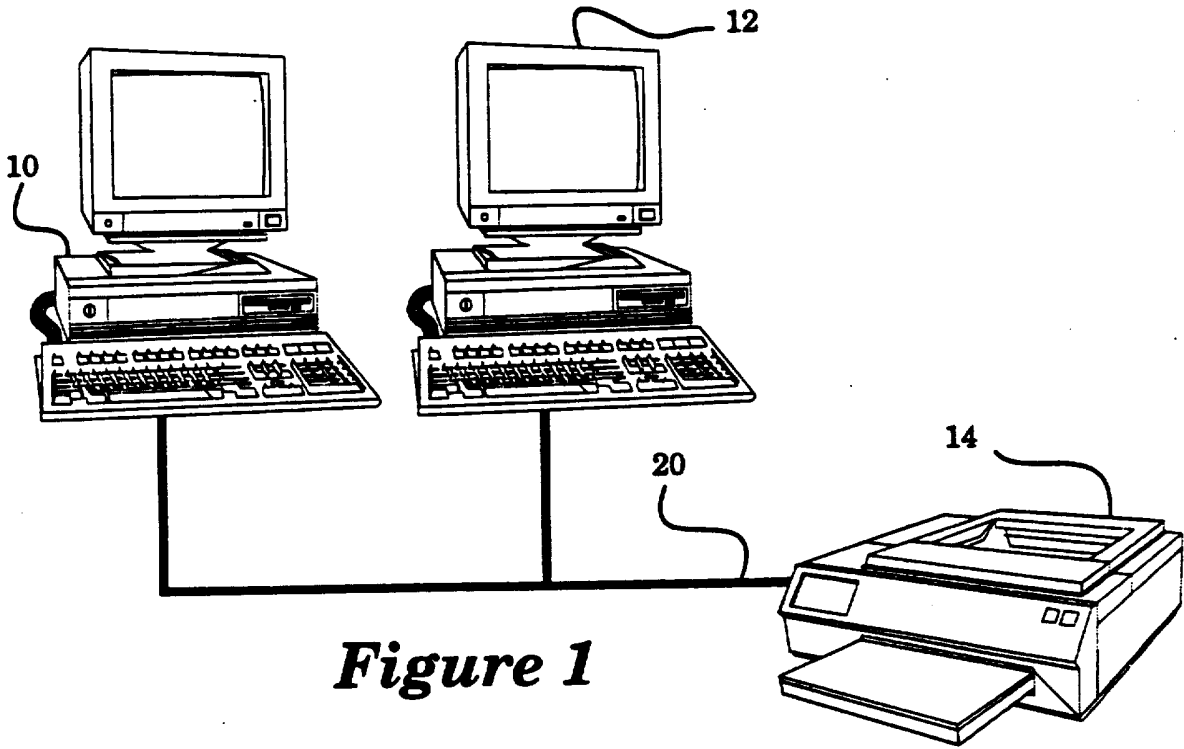

**Figure 1**

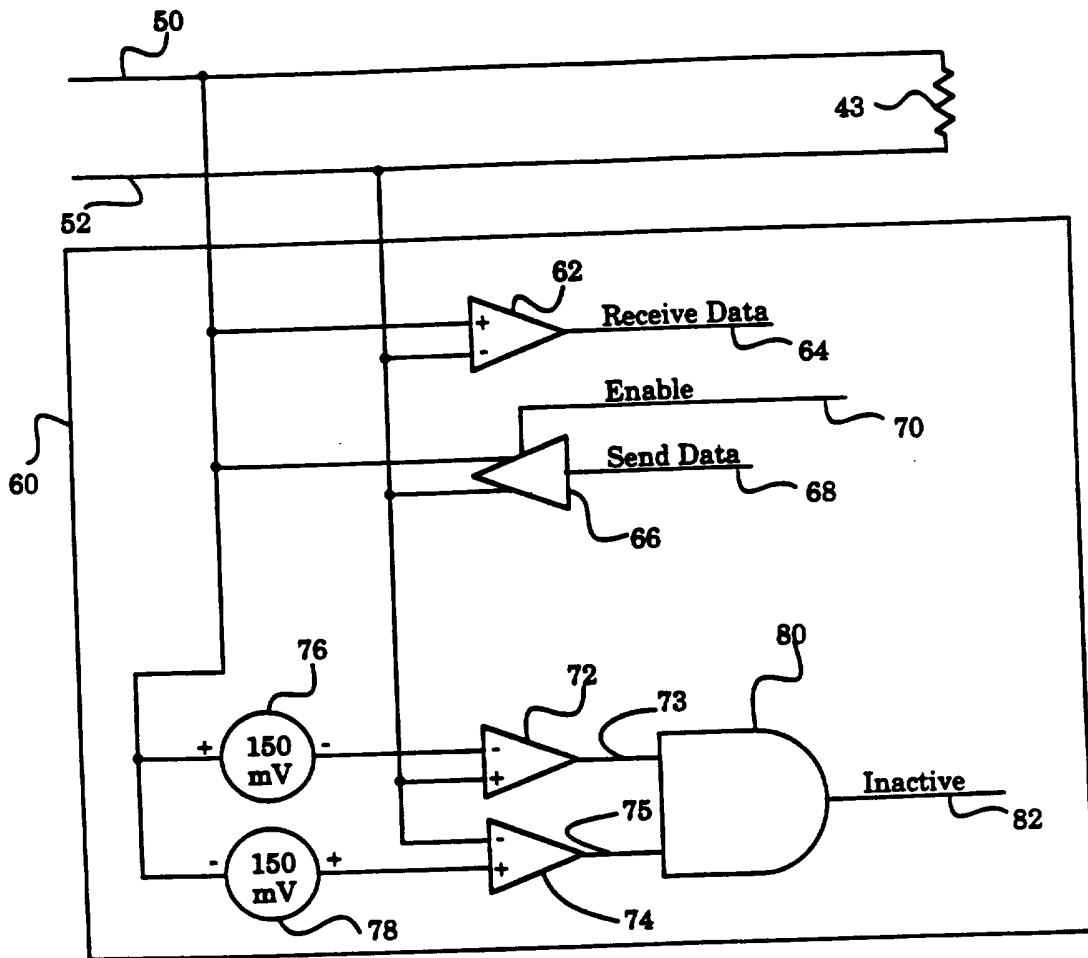

**Figure 2**

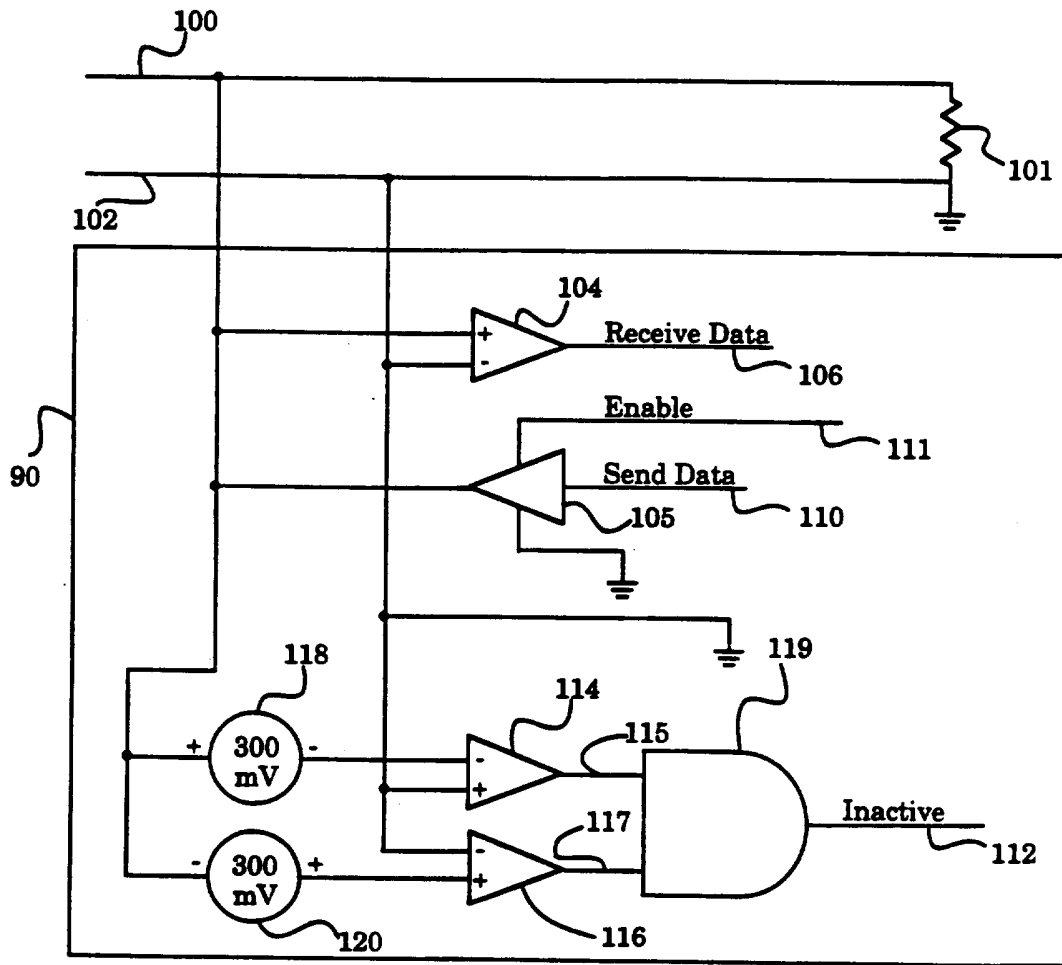

**Figure 3**



# INTERNATIONAL SEARCH REPORT

International application No.  
PCT/US95/16879

## A. CLASSIFICATION OF SUBJECT MATTER

IPC(6) : H04L 25/06, 25/10; H03K 3/013, 5/22  
US CL : 395/200.11; 371/63; 327/65, 72

According to International Patent Classification (IPC) or to both national classification and IPC

## B. FIELDS SEARCHED

Minimum documentation searched (classification system followed by classification symbols)

U.S. : 395/200.11; 371/63; 327/65, 72

Documentation searched other than minimum documentation to the extent that such documents are included in the fields searched  
395/200.13, 200.14, 200.20, 185.02; 364/266, 266.6

Electronic data base consulted during the international search (name of data base and, where practicable, search terms used)

USPTO APS

search terms: detect, sense, threshold, voltage level, comparator, valis signal, lan, network, two wire, wire pair

## C. DOCUMENTS CONSIDERED TO BE RELEVANT

Category*	Citation of document, with indication, where appropriate, of the relevant passages	Relevant to claim No.
A, P	US, A, 5,440,253 (ARAYA) 08 August 1995, see Abstract; Fig. 3; Col. 3, lines 35-47; Col. 15, lines 29-60.	1-32
A	US, A, 5,179,577 (ILYADIS) 12 January 1993, see Abstract; Fig. 4; Col. 3, lines 13-35; Col. 7, line 51 - Col. 8, line 62.	1-32
A	US, A, 4,933,869 (GAREIS et al.) 12 June 1990, see Abstract; Fig. 3-5; Col. 1, lines 31-63; Col. 4, line 34 - Col. 5, line 32.	1-32
A	US, A, 4,924,117 (TAMARU) 08 May 1990, see Abstract; Col. 2, lines 22-37.	1-32

Further documents are listed in the continuation of Box C.  See patent family annex.

Special categories of cited documents:		later document published after the international filing date or priority date and not in conflict with the application but cited to understand the principle or theory underlying the invention
*A* document defining the general state of the art which is not considered to be part of particular relevance	*T*	
*E* earlier document published on or after the international filing date	*X*	document of particular relevance; the claimed invention cannot be considered novel or cannot be considered to involve an inventive step when the document is taken alone
*L* document which may throw doubts on priority claim(s) or which is cited to establish the publication date of another citation or other special reason (as specified)	*Y*	document of particular relevance; the claimed invention cannot be considered to involve an inventive step when the document is combined with one or more other such documents, such combination being obvious to a person skilled in the art
*O* document referring to an oral disclosure, use, exhibition or other means		
*P* document published prior to the international filing date but later than the priority date claimed	*Z*	document member of the same patent family

Date of the actual completion of the international search  
15 APRIL 1996

Date of mailing of the international search report  
**26 APR 1996**

Name and mailing address of the ISA/US  
Commissioner of Patents and Trademarks  
Box PCT  
Washington, D.C. 20231

Authorized officer: *B. Nardhi*  
MARK H. RINEHART  
Telephone No. (703) 305-9600

Facsimile No. (703) 305-3230