



(12) APPLICATION

(11) 20241168

(13) A1

NORWAY

(19) NO

(51) Int Cl.

F03D 3/02 (2006.01)

F03D 3/04 (2006.01)

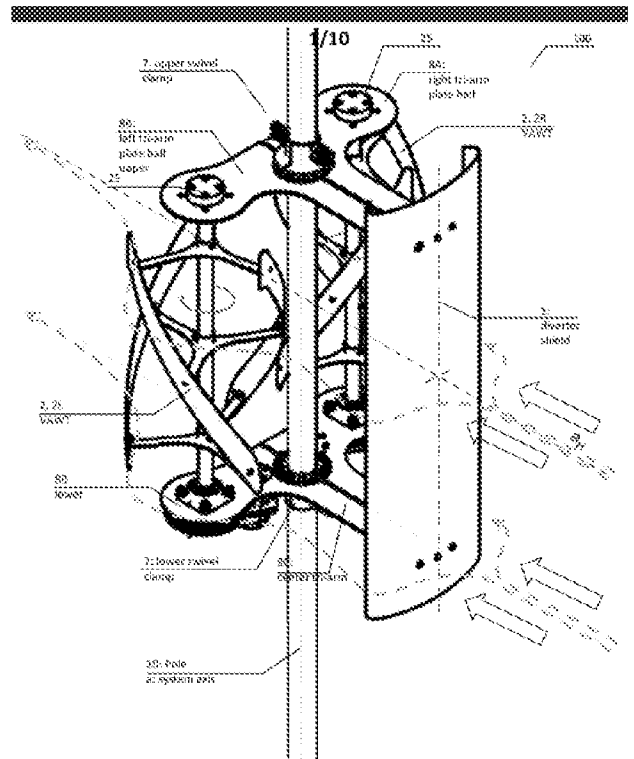
F03D 3/06 (2006.01)

Norwegian Industrial Property Office

(21)	Application No	20241168	(86)	Int. application date and application No
(22)	Application date	2024.11.26	(85)	Entry into national phase
(24)	Date from which the industrial right has effect	2024.11.26	(30)	Priority
(41)	Available to the public	2025.05.19		
(71)	Applicant	InAfrica Integrated Holdings Ltd, Kanika Alexander Center, Suite 113B, Georgiou Karaiskaki 38, 3032 LIMASSOL, Kypros		
(72)	Inventor	Louis Van Pletzen, High Leigh, Traps Lane, KT34RY NEW MALDEN, Storbritannia Emily Roos, 15 Pellatt Grove, N225NP LONDON, Storbritannia		
(74)	Agent or Attorney	ACAPO AS, Edvard Griegs vei 1, 5059 BERGEN, Norge		

(54) Title **Dual Axis Urban Wind Turbine**  
 (57) Abstract

A compact wind turbine system arranged for retrofitting to existing poles is provided. The invention achieves its objectives using a twin vertical axis wind turbine downwind from a diverter shield.



**TITLE: Dual Axis Wind Turbine System****Field of the Invention**

The invention relates to wind turbines in general and more specifically a compact  
5 wind turbine suited for retrofitting to existing poles such as light poles.

**Background Art**

State of the art is reflected in traditional vertical axis wind turbines (VAWTs).

10 From prior art one should refer to US D675,983 S. This US design patent shows a twin vertical Savonius wind turbine with twin S-shaped turbine blades, located downwind from a vertical plate, the two vertical wind turbine axles held on bearings on a lower plate-shaped arm structure on a support cylinder with a bottom attachment flange. The bottom attachment flange constitutes a single bearing for  
15 being arranged on top of a mast.

The applicant has tested an example of US D675,983 "BeWind". It showed out that its stiffness due to its a single bearing on the mast the bottom could only handle a down force or just one wind direction; it quickly collapsed after the whole device  
20 wobbled in the wind which cracked the frame. Before breaking down, the wobble caused the turbines to lose rotational momentum.

"Development of the Dual-Vertical-Axis Wind Turbine with Active Blade Pitch Control", Daniel McLean, M. Appl. Sci. thesis, Mechanical, Industrial and Aerospace  
25 Engineering, Concordia University Montreal, Quebec, Canada, December 2017, discusses single Vertical Axis Wind Turbines with axis parallel blades, and parallel double vertical axis wind turbines with vertical wings arranged between pairs of horizontally arranged conveyor belts. The long sides of the oval path run across the incoming wind and the downstream wind. McLean concludes that active-pitch control  
30 is able to equilibrate load but not able to increase power extraction. The downstream wind field on the downstream running wing is reduced in the wake of the upstream running wing. Due to a flow field interaction, active-pitch is unable to improve the cycle-averaged power coefficient for that turbine design.

35 In rural areas and also in more densely populated parts of South Africa and throughout most of Africa, the electrical energy infrastructure is not always available

or has an insufficient power capacity. However, there may be arranged lamp posts along roads wherein one may mount wind turbines onto, often in windy conditions along coastal roads and promenades. Wind turbines arranged on such lamp posts could provide much energy locally, but are vulnerable to fatigue. The relative low  
5 height of many lamp posts dictates a relative short VAWT, which is solved by twin VAWTs mounted high up on the pole. However, changing wind directions make the use of twin VAWTs in a fixed position inefficient for most wind directions outside the dominating wind direction. Swivel mounted twin VAWTs may be orient themselves toward the wind but the swivel mount is vulnerable to wear and fatigue and the  
10 swivel mount may break off the top of the pole. Also, the heading of swivel mounted twin VAWTs may be unstable and may overshoot the wind direction changes.

Horizontal axis wind turbines (HAWTs) generate much noise as their wing tips may have very high velocities, and are highly unpopular in urban environments due to  
15 their noise. Due to the large vertical wingspan required for a horizontal axis wind turbine to work efficiently it must be arranged in a tower mounted nacelle with an elevation more than its turbine radius above ground. Everywhere they are met with a "not in my backyard" attitude. They take a lot of space and kill birds indiscriminately. Maintenance and repair are expensive due to the extreme elevation of the nacelle.

20

Urban environment experiences more turbulence and variations in wind directions than in typical wind farm fields. This makes static direction double axis VAWT less useful.

25 There is therefore a need for a method and a system to overcome the above mentioned problems.

### **Brief summary of the Invention**

The invention provides a wind turbine system, comprising a diverter shield (1) positioned leading of and facing a wind direction, a pair of counter rotating vertical  
30 axis wind turbines (VAWTs) (2) symmetrically positioned downwind of said diverter shield, wherein said diverter shield (1) is located so that parts of said counter rotating VAWTs that rotate up against the wind direction are shielded by said diverter shield.

### **Problems to be Solved by the Invention**

35 A main objective of the present invention is to provide a double axis vertical axis wind turbine (VAWT) system capable of utilizing existing mechanical infrastructure. It

is an objective that the device of the system shall be easily assembled and mounted in situ at the existing infrastructure. Another object is for the wind turbine system is to enable utilizing wind of varying directions. Another object is to reduce the negative effect of the actively working wings on the passively returning wings of the VAWTs.

5 Another object of the invention is to easily utilizing existing electrical infrastructure of existing solar panel plants or local or regional grids.

### **Means for Solving the Problems**

10 The objective is achieved according to the invention by a wind turbine system as defined in the independent claims.

A number of non-exhaustive embodiments, variants or alternatives of the invention are defined by the dependent claims.

### **Effects of the Invention**

15 The invention has advantages over the above background art in that it is mechanically far less vulnerable than the above mentioned background art. The invention has advantages when subject to wind of varying directions. The invention has advantages with regard to the problem of wobbling. The invention has  
20 advantages with regard to ease of manufacture, most of the major components such as the diverter shield, the tri-armed brackets for holding the turbine wings and the turbine wings themselves, the right and left combined tri-lobe pole mounting plates, may all be formed from metal plates, and do all enable flat packing which is an enormous advantage for easy manufacture and easy transport to the assembly and  
25 mounting site. Another advantage of the invention is the ease of integration in a solar plant.

### **Brief Description of the Drawings**

The above and further features of the invention are set forth with particularity in the appended claims and together with advantages thereof will become clearer from  
30 consideration of the following detailed description of an exemplary embodiment of the invention given with reference to the accompanying drawings.

The invention will be further described below in connection with exemplary embodiments which are schematically shown in the drawings, wherein:

35

**Fig. 1** is an isometric view an embodiment of the invention showing an assembled wind turbine system with contra rotating Darrieus helical wind turbines arranged on a pole structure, and indication of an incoming wind direction. The pole structure may be an existing light pole of steel, aluminium, wood, or the like.

5

**Fig. 2a, b, and c** comprise a top view and lateral and rear elevation views of an assembled wind turbine system corresponding to the one of **Fig. 1**, also arranged on a pole structure. In **Fig. 2a** is illustrated incoming wind along the horizontal axis (aH) of the wind turbine system, onto the diverter shield. A wind flow is illustrated about the right side of the diverter shield and onto the right vertical axis wind turbine VAWT (2, 2R).

**Fig. 3a, b, and c** are a top view and lateral elevation views of an embodiment of the diverter shield (1). The upper view Fig. 3c further shows the angle larger than 90 degrees of which the lateral vertical edges of the diverter shield is bent inwardly relatively to the flatter front portion plane. Fig. 3d illustrates an upper or lower shield bracket (83) for fixing the diverter shield (1) to the center tri-arm (8C) of the wind turbine system of the invention.

**Fig. 4** is an isometric "perspective" view of a wind turbine (2) of an embodiment of the invention, a Darrieus turbine with helical blades (23a, b, c) mounted on three three-armed brackets (26) on the rotation axis. In the illustrated embodiment of the invention the helical blades are plate shaped and may be bent into their helical shape during in situ assembly. They may be transported in their plate shape for flat packaging advantage, or transported in bent shape for even easier assembly.

**Fig. 5** is an isometric "perspective" view of a pulley (4) and belt (5) transmission to a generator (3, 32) according to an embodiment of the invention. The wind turbine axle mounted pulley (4) may also act as a flywheel.

**Fig. 6** is a bottom view and elevation views of the pulley and belt transmission to the dynamo according to an embodiment of the invention. The pulley (4) is arranged for being connected to the axle (22) of a VAWT (2), please see **Fig. 4**. The generator (3) is arranged for being fixed to a horizontally arranged tri-lobed swivelling pole mounting plate (8A or 8B) holding the VAWT (2), please see **Fig. 2a** and **Fig. 2b**.

35

**Fig. 7A** is a bottom view of an assembled split swivel clamp (7A or 7B) with a split bearing bolt flange ring (72A), and elevation views of the split swivel clamp (7, 7A, 72B) according to an embodiment of the invention. To the upper right is an isometric view of the split swivel clamp (7A, 7B).

5

**Fig. 7B** illustrates an upper and lower assembled split swivel clamp (7, 7A, 7B) on a pole, according to an embodiment of the invention. The swiveled assembly of upper and lower tri-arm plates with right and left VAWTs (2) is illustrated arranged resting on the lower bearing ring (76) of the lower swivel clamp (7) and held in place by the upper bearing ring (76) held in place by the upper, fixed, swivel clamp (7). In an embodiment the lower swiveling tri-arm plate (8) assembly shares an electrical slip ring (72) with the lower swivel clamp (7).

**Fig. 7C** shows assembled upper and lower split swivel clamps with part indicated joined tri-arm plates (8, 8A, 8B) assembled 90 degrees off, isometric view and with section plane for **Fig. 7B**.

**Fig. 7D** shows upper and lower half tri-arm plates (8A, 8B) in plane view with shield bracket (83), and isometric view, before assembly.

20

**Fig. 8a** is a lateral and axial view and perspective views of the split swivel clamp coupling ring (71, 71A, 71B) according to an embodiment of the invention, this is mounted 90 degrees together with the split swivel clamp relative to the tri-arm plate (8), please see **Fig. 1**, **Fig. 7C**. **Fig. 8b** is an axial bearing ring half (76A, 76B), please also see **Fig. 7A** and **Fig. 7B**. **Fig. 8c** is a split plate flange bearing ring half, please also see **Fig. 7A**, **Fig. 7B**, **Fig. 7C** These three rings are assembled 90 degrees turned relative to the split of the joined tri-lobe plate (8), see Fig 1 and **Fig 7C**.

**Fig. 9** is a top view of wind generated torques when the wind direction is to the left of the horizontal center line through the shield arm, the wind generated torques creating a righting torque into the wind direction. The righting torque of the diverter shield may be less than the righting torque of the turbines, contributing to attenuating the righting movement and stabilize the shield up against the wind and splitting the incoming wind flow onto the more exposed outer parts of the right and left VAWTs (2). This works even if the right and left VAWTs (2) are not synchronized in speed.

30  
35

**Fig. 10** is a top view of an embodiment of the invention having synchronized rotation meshed blades (23) of VAWTs (2). An advantage is that it is even less air resistance in a common low vacuum blade return region behind the diverter shield and between the VAWTs (2) meshed blades.

5

**Fig. 11** is a bottom view principle sketch of an embodiment of the invention using a common generator of two VAWTs(2) wherein right and left pulleys (4) are synchronized via a common generator (3) pulley.

10 **Fig. 12** illustrates a split electrical slip ring (72) to be used in conjunction with the split swivel clamp (8) above. Please also see **Fig. 7B**

15 **Description of the Reference Signs**

The following reference numbers and signs refer to the drawings:

10	Pole
a	pole axis, system axis
aH	horizontal axis through diverter shield and symmetry line of tri-arm plate
100	The wind turbine system
1	Diverter shield
11	Diverter shield vertical edges
12	Diverter shield folds
15	heat element
2, 2R, 2L	Right and left vertical axis wind turbine VAWT
22	Turbine shaft, turbine axle
23a, b, c	turbine wingsings, helical turbine blades
24	protruding fin at end of wing
	Upper end of wing
	Lower end of wing
26	Wing brackets
3, 32, 31, 31c	Generator, double, single, or contra-rotating

4, 4F	pulley, flywheel
5	drive belt
6	DC battery system
7, 7A, 7B	swivel clamp, split swivel clamp halves
71A, B	split plate coupling rings, with bolt holes
72	split electrical slip ring
74	proximal bearing flange with radial rim for bearing ring
76, 76A, B	bearing ring, split halves of bearing ring
77A, B	split flange bearing ring, with bolt holes
8, 8A, 8B, 8C	tri-arm plate, right and left half tri-arm, center tri-arm for shield
83	shield bracket

## Description of embodiments of the Invention

5 Various aspects of the disclosure are described more fully hereinafter with reference to the accompanying drawings.

The invention provides a wind turbine system, comprising:  
a diverter shield (1) positioned leading of and facing a wind direction,  
a pair of counter rotating VAWTs (2) symmetrically positioned downwind of said  
10 diverter shield,  
wherein said diverter shield (1) is located so that parts of said counter rotating  
VAWTs (2) that rotate up against the wind direction are shielded by said diverter  
shield (1), please see **Fig. 1**.

15 A main idea is that the diverter shield (1) separates the incoming wind flow into a right and a left flow relative to the diverter shield, which flows engage more with the relatively outer parts of the pair of the left VAWT (2L) and the right VAWT (2R), respectively, leaving a wake in the relatively middle parts (near the vertical system axis (a), please see below), of the VAWTs behind the diverter shield. It is believed  
20 that this has a positive effect on the efficiency of the two VAWTs (2).

In an embodiment of the invention the VAWTs (2) are Darrieus turbines. Turbine blades (23) are arranged on tri-armed brackets on their common axle (22). In a further embodiment of the invention the wind turbine blades (23) are helical as illustrated in **Fig. 1**, **Fig. 2**, and **Fig. 4**.

5

The helical wind turbine blades may be oppositely directed as in **Fig. 1**, being pure mirror images, but an alternative is that the two helix arrangements are helically directed the same way, the left VAWT (2B) "upside down" relative to the right one.

10 In an embodiment of the invention the helical wind turbine blades (23) are oppositely directed on the right VAWT (2R) relative to the left VAWT (2L), as shown in **Fig. 1** and **Fig. 2**.

In an embodiment of the invention each helical blade (23) has a protruding fin (24) extending laterally at one end of the blade (23). Please see **Fig. 4**. The protruding fins will be differentially exposed to the incoming wind and may aid in starting up the wind turbines.

15 In an embodiment of the invention each helical blade (23) has a protruding fin (24) extending laterally at one end of the blade (23). Please see **Fig. 4**. The protruding fins will be differentially exposed to the incoming wind and may aid in starting up the wind turbines.

20 In an embodiment of the invention, the wind turbine system is rotationally positioned around a vertical system axis (a), please see **Fig. 1**, wherein said vertical system axis (a) is located between said diverter shield (1) and said pair of VAWTs (2), and wherein said diverter shield (1) contributes to rotate and direct the wind turbine system around said system axis (a) and align the wind turbine system so that said diverter shield (1) is maintained in a direction facing the wind direction, please see

25 **Fig. 9**.

In an embodiment of the invention said pair of counter rotating VAWTs (2), and said diverter shield (1) are mounted arranged on and about a pole, thus the axis (a) is in the axis of the supporting pole, please see **Fig. 2**.

30

As examples of poles to mount the wind turbine system of the invention onto, it may be arranged on light poles or electricity poles or other poles such as fence poles associated with the existing solar panel plant. An advantage is that one does not have to establish a separate structure as road lighting infrastructure may be utilized more or less for free. The invention's wind turbine system and a solar power system may work complementary mutually; if the sun is down or if the rain pours down, the

35

wind may blow, and if there is windstill, the sun may be up, so more power will be available regardless.

5 In an embodiment of the invention said diverter shield (1) is arranged vertically, parallel to axes of said VAWTs (2), please see **Fig. 2** lower left and right illustration. The diverter shield (1) and its mounting bracket (83) is shown in **Fig. 3**.

10 In an embodiment of the invention the diverter shield (1) at its vertical edges (11) is folded back by more than 90 degrees relative to a plane transverse to the main horizontal axis ( $a_H$ ) through the wind turbine system, please see upper left part of **Fig. 2**, the top transparent view.

15 In an embodiment of the invention, said diverter shield (1) is vertically of longer extension than said VAWTs (2) so as to form a low pressure "blade return" region behind said diverter shield (1), please see upper left part of **Fig. 2**, the horizontal section, and the lower right portion, the rear view elevation view.

20 In an embodiment of the invention said two VAWTs (2) are positioned so that at least parts of a periphery of each VAWT (2) overlap, so that VAWT blades (23) mesh in said "blade return" region behind said diverter shield (1), please see **Fig. 10**. (Please note that in all other Figures of the application, the blades (23) do not mesh.)

25 In an embodiment a generator (3) is driven by at least one of said VAWTs (2), please see of **Fig. 2**, lower right part, an elevation view. **Fig. 5** illustrates an isometric "perspective" view of a pulley (4) on a VAWT (2) axle (22) and a belt (5) transmission to a corresponding pulley on said generator (3, 32). In an embodiment the opposite VAWT (2) has a mirror image arrangement of this arrangement.

30 In an embodiment of the invention each VAWT (2) has a flywheel. In an embodiment shown in **Fig. 5** and **6**, this is constituted by the pulley (4) so as for pulley (4) to act as a flywheel. The flywheel contributes to stabilizing the rotational speed of the VAWT (2). The VAWTs themselves act as flywheels.

35 In the illustrated embodiment of **Fig. 5** and **6**, the pulley (4) is much larger than the corresponding generator pulley so the rotational speed of the generator rotor will be correspondingly larger. This is advantageous for the voltage produced by the generator (3).

In an embodiment of the invention said generator (3, 3D) is a DC generator.

5 In a further embodiment said DC generator (3, 3D) is connected to a DC battery system (6).

In a further embodiment of the invention said DC battery system (6) is also a DC battery system (6, 6S) of a solar panel power plant.

10 An advantage of using one or more DC generators (3, 3D) is the possibility to feed the DC generated voltage ( $V_{DC\ G}$ ) onto a receiving battery pack (6) wherein there is only need to feed the generated voltage ( $V_{DC\ G}$ ) being higher than the battery pack voltage ( $V_B$ ) at any time. If the wind is too weak to directly result in a sufficiently high voltage, an insufficient DC voltage ( $V_{DC\ G}$ ) may be run through an  
15 inverter/transformer to generate a transformed generated voltage ( $V_{DC\ T}$ ) being higher than the battery pack voltage ( $V_B$ ) at any time.

The problems relating to produced voltage ( $V_{DC\ G\ or\ T}$ ) is very similar to the situation with a solar power plant, which also may have variations in the DC voltage  
20 generated ( $V_s$ ) from the solar panels, which also usually feed a battery pack through a voltage regulator device. The produced voltage ( $V_{DC\ G\ or\ T}$ ) from the wind turbine system may be fed into an existing solar panel array's battery pack and be controlled in a regulator system for such a solar panel array's battery pack.

25 Further, if the task is to feed the local or regional AC grid, the voltage ( $V_B$ ) from the battery pack may be run through an inverter system to form AC with a single-phase or 3-phase voltage ( $V_{AC}$ ) and frequency and phase adapted to the local single phase or 3-phase grid to be matched.

30 In an embodiment of the invention wherein there is a requirement for the rear system to receive only AC, said generator (3, 3A) is an AC generator. This may be less advantageous due to the further need to control the speed or invert the instantaneous frequency to an acceptable frequency (and voltage) for the grid. Controlling the rotational speed of the VAWTs (2) in order to match a receiving AC  
35 grid directly is disadvantageous as braking may be required, a waste of energy.

In an embodiment of the invention, such as in **Fig. 1, Fig. 2** illustrated, each VAWT (2) is connected to each its electrical generator (3, 32).

In an embodiment, the blades (23) are made having a wing-profile, but the  
 5 embodiment of flat wing profiles such as in **Fig. 4** will do, much due to the presence of the diverter shield (1).

There are two alternatives: either the embodiment shown in **Fig. 2B and 2C** wherein each VAWT (2) axle (22) is connected via a pulley (4) and belt (5) transmission to  
 10 each its separate generator (3, 32) or wherein both VAWT (2) axles (22) are connected via a pulley (4) and belt (5) transmission to a common generator (3, 31), please see Fig. 11.

Using a common generator (3, 31) or using two generators (3, 32), regardless of  
 15 synchronizing the counter rotation of the two VAWTs (2), has an advantage of creating a righting torque of the wind turbine system which turns the wind turbine system into the incoming wind direction, please see **Fig. 9**. The right and left wind turbines (2R, 2L) may be synchronized or not. If the wind comes in from the right of the horizontal center line (aH), the right wind turbine (2R) is more exposed to the  
 20 incoming wind than the left wind turbine (2L), so the right will brake the wind and the left one will "push" the wind, please see upper half of **Fig. 9**. So the torque on the left, "leeward" VAWT (2L) is lower than the torque on the right "lo" VAWT (2R):

$$\tau_R > \tau_L$$

and set up a relatively weak righting torque

$$25 \quad \tau_{\text{sum}} = \tau_R - \tau_L$$

up towards the incoming wind direction.

In an embodiment the synchronization is done via a register belt, a common driven generator, a single drive belt, or the like. An advantage of synchronizing is that this will, in case the wind comes in from one of the side, make the wind side VAWT  
 30 heavier to drive, and the leeward VAWT easier to drive, and they will rotate the wind turbine system with the deviation shield into the wind direction. Moreover synchronized rotation speed of the generators (3) of one wind turbine system will simplify the electrical system as there will be no voltage difference between right and left generator.

35

In an embodiment of the invention, each VAWT (2) drives a respective part of a contra rotating generator (3, 30), please see **Fig 11**, i.e. wherein one turbine axle rotates the rotor, and the other turbine axle rotates the stator (a rotating stator) of the generator 3, 30. An advantage of using a contra rotating generator (3, 31c) is that  
5 the relative rotational speed is the double (the sum) of the stator's rotation one way and the rotor's rotation the opposite way, thus the generator may be less voluminous or the generator may produce a higher voltage resulting in a lesser requirement for conductor cross section. The drive belt (5) of the right VAWT (2) may run the rotor, and the opposite drive belt (5) of the left, opposite VAWT (2) may run the rotatable  
10 stator of the generator (3, 30), please see of **Fig. 11**.

In an embodiment if the invention the wind turbine system is assembled as follows:

#### **Method of the invention**

15

The invention also provides a method of assembling a wind turbine system, please see **Fig. 1**.

Overall, the invention provides a method for the assembly of the wind turbine system  
20 as follows:

- Provide a pole,
- establish an assembled split swivel clamp with bearing on top, at a first, lower turbine level on the pole,
- 25 - assemble right and left turbines on left and right, upper and lower tri-arm plates, respectively,
- arrange and connect said right and left turbine assemblies about the pole.
- axially lock the upper tri-arm plates in an assembled upper swivel clamp at an upper turbine level,
- 30 - mount the diverter shield,
- connect generator to swivel and swivel to voltage receiving system,
- release wind turbine system to rotate into the wind.

Now the VAWTs will start counter-rotating, the wind turbine system will start  
35 generating electrical energy.

A more elaborate, detailed method is as follows: Before assembly, provide a suitable vertical pole (10) as support structure for the wind turbine system. The pole may be a lamp post or similar, e.g. made in steel, aluminium, glass fibre, wood. This is an advantage of the invention: there may be no investment in novel support structures for installing the wind turbine system of the invention.

The method in a more detailed embodiment comprises the steps of

- 10 i) assemble and fix a lower swivel clamp's (7) halves (7A, 7B) about a lower attachment level on the pole, please see **Fig 7B**. Assemble split axial bearing ring (76) halves (76A, 76B) on top of said lower swivel clamp (7), also see **Fig. 7B** and **Fig. 8**, and **Fig. 7A**, upper right perspective drawing.
- 15 ii) assemble an upper swivel clamp (7) about the pole and attach it temporarily just above an upper attachment level on the pole, Please see **Fig. 7B**, upper part, to provide clearance sufficient to assemble the upper and lower plates (8) carrying the VAWTs (2) in-between. With "just above", we mean that there shall be sufficient space for inserting the VAWT assembly between the lower and upper clamp so as for lowering the upper clamp to lock the swivelling assembly, please see below.
- 20 iii) assemble right and left vertical axis wind turbines (VAWTs) (2, 2A, 2B) in upper and lower turbine bearings (25) on right and left, upper and lower tri-arm plate halves (8A, 8B), please see **Fig. 7D**. Generators, pulleys may be arranged at any time later to keep down the lifting weight. Arrange the right and left assembly in an elevation level between lower and upper swivels (7) at either sides of the pole, please see **Fig. 7B**, and keep in position by straps or temporary joining clamps.
- 25 iv) join said right and left lower tri-arm plate halves (8 8A, 8B) and join said right and left upper tri-arm plate halves (8, 8A, 8B) about the pole, forming complete upper and lower tri-arm plates (8) now holding said right and left VAWTs (2), see **Fig 7B**,

In an embodiment, bolt join said first and left tri-arm plate halves (8A, 8B) by

- 35 - using a first and second split plate coupling ring (71A, 71B) at a proximal side of each tri-arm plate (8) (the turbine side) and
- using a first and second split plate coupling ring (71A, 71B) and
- a split plate flange bearing ring (77A, 77B)

at a distal side of each tri-arm plate (8), for facing each clamp (7), please see Fig 7B. Bolt holes are ready.

5 v) mount the diverter shield (1) on aligned upper and lower center arms (8C) of the assembled tri-arm plates (8). Mount said diverter shield (1) on shield brackets (83) , see Fig. 3, on the center arms (8C), see Fig. 2a.

10 vi) lower the assembled lower tri-arm plate (8) down onto the lower swivel clamp (7), see Fig 7B, now supporting the assembled VAWTs (2, 2A, 2B) with the diverter shield (1). Land the assembled lower tri-arm plate (8) on the assembled axial bearing ring (76) on top of said lower swivel clamp (7).

15 vii) lock an upper part of the electrical slip ring to (72) to the lower tri-arm plate (8), connect to the generator (3), see Fig. 7B.

viii) lock a lower part of the electrical slip ring to the lower clamp (7) and connect to the voltage receiving device (6), see Fig. 7B.

20 ix) lower the upper swivel clamp (7) down onto the upper tri-arm plate (8), and fix the upper swivel clamp (7) at the upper attachment level on the pole, see Fig 7B, upper half. This step may be done any time after step (vi).

25 Then we may allow the swivelling vertical axis wind turbines (VAWTs) (2) with the shield (1) to swing into the wind direction to produce electrical energy to the voltage receiving device (6).

30 To give an indication of dimensions of the wind turbine system of the present invention, in an embodiment of the invention the width of each vertical axis wind turbine (2) is 606 mm, the axial length is 1370 mm. The illustrated embodiment is arranged for mounting a pole with radius 56 mm, Ø 112 mm. Other embodiments may have a VAWT diameter of 0.5 to 2 m or more, and an axial length of 1 m to 4 m or more. A limitation in the size of the wind turbine system of the invention is of course the structural strength of the pole onto which the wind turbine system is to be  
35 made by the person skilled in the art.

An advantage of the invention is that no meteorological measurements for finding the prevailing wind direction is required. The wind turbine system works regardless of the varying direction of the incoming wind. In an embodiment of the invention the diverter shield (1) may be provided with electrical heating elements (15) at their rear face to prevent clogging of snow or ice in order to maintain stability under cold conditions, otherwise the rotating VAWTs will keep themselves free of snow and ice.

A disadvantage of most existing horizontal - axis wind turbines is the noise induced due to high wing tip speed. Such HAWTs are usually very large and mounted in extremely tall towers, more than 100 m is not uncommon, and due to the noise and visual disturbance more and more people want them in their vicinity. The present invention, in most embodiments, is relatively small, and incurs little noise. Moreover, the constant turbine outline is not as visually disturbing as rotating tri-wing horizontal axis turbines.

Most components of the wind turbine system of the invention may be made in aluminium plate, except for the generator (3), the upper and lower swivel clamps (7), and the axles of the VAWTs (2), and the pulleys. Even the VAWT wings may be made in flexible aluminium plate. Thus, most of the wind turbine system may be flat packed and transported with very small volume, with the generator and pulleys and clamp halves packed in a box. An embodiment of the invention will be less than about 80 to 100 kgs while assembled, thus all components (wherein the two main halves comprising each VAWT (2), to be lifted, weigh less than 40 kg, less than half of the total weight, may be handled by one person, and two persons will have no problems assembling the components and conduct the mounting process indicated above, using a minimum of or no hoisting machinery. One or more such wind turbine systems may be mounted on one more existing lamp posts or electrical poles along a road.

The two levels of swivel clamps on the pole reduces the bending moment on either swivel clamp (7, 7), and thus prevents fatigue in either swivel clamp and overcomes a significant problem of the prior art. Wobbling is avoided. Breakage is unlikely.

In an embodiment of the invention the wind turbine system has one or more of said swivel clamps having at least one split electrical slip ring (72) connection from the output of said generator (3). Please see **Fig. 12, Fig. 7B**. An electrical conductor runs from the electrical slip ring (72) to a voltage receiving device (6). A hole may be

made in the pole in order to thread the electrical conductor lead from the slip ring (72) inside the pole, either upward to a grid line on the pole or down to a buried grid line.

- 5 If the generator (3) is a DC generator (3, 3D), there is strictly only one electrical slip ring (72) required for each generator's (3, 3D) "plus" voltage, the "ground" or "minus" voltage signal may go via the structural support directly to the pole if it is a steel pole, and the receiving battery system may be similarly grounded.

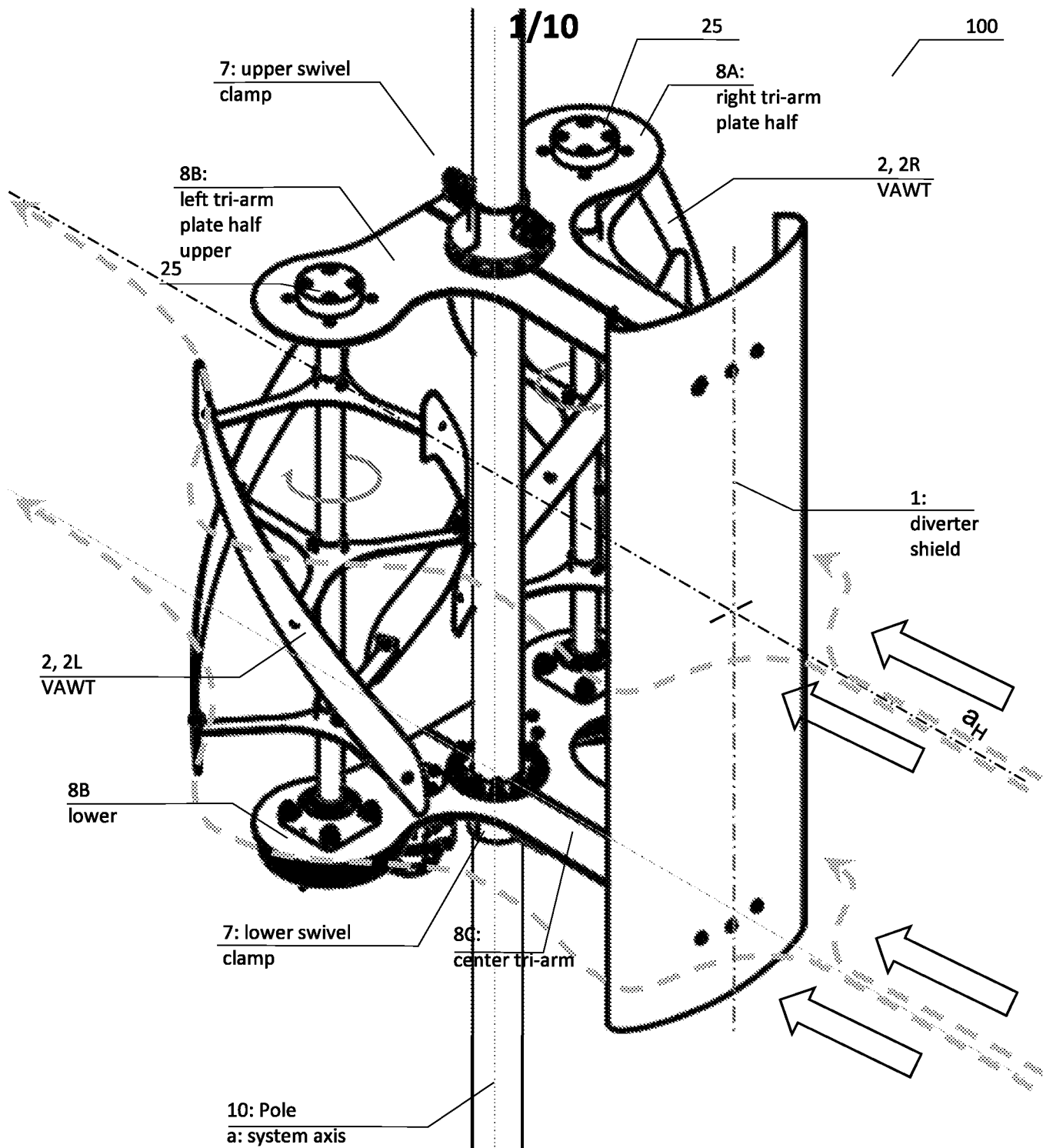
### Claims

1. A wind turbine system, comprising:  
a diverter shield (1) positioned leading of and facing a wind direction,  
5 a pair of counter rotating vertical axis wind turbines (VAWTs) (2)  
symmetrically positioned downwind of said diverter shield,  
wherein said diverter shield (1) is located so that parts of said counter rotating  
VAWTs (2) that rotate up against the wind direction are shielded by said diverter  
shield (1).  
10
2. The wind turbine system according to claim 1,  
wherein the wind turbine system is rotationally positioned around a vertical  
system axis (a),  
wherein said vertical system axis (a) is located between said diverter shield  
15 (1) and said pair of counter rotating VAWTs (2),  
wherein said diverter shield (1) contributes to rotate the wind turbine system  
around said system axis (a) and align the wind turbine system so that said diverter  
shield (1) is maintained in a direction facing the wind direction.
- 20 3. The wind turbine system according to claim 1 or 2, wherein said pair of  
counter rotating VAWTs (2), and said diverter shield (1) are mounted, or arranged,  
on and about a pole.
4. The wind turbine system according to one of the preceding claims, wherein  
25 said diverter shield (1) is arranged vertically, parallel to axes of said pair of counter  
rotating VAWTs (2).
5. The wind turbine system according to one of the preceding claims, wherein  
the diverter shield at its vertical edges (11) is bent away from front of said diverter  
30 shield (1) by more than 90 degrees.
6. The wind turbine system according to one of the preceding claims, wherein  
said diverter shield (1) is vertically of longer extension than said pair of counter  
rotating VAWTs (2), so as to form a low pressure "blade return" region behind said  
35 diverter shield (1).

7. The wind turbine system according to claim 6, wherein said pair of counter rotating VAWTs (2) are positioned so that at least parts of a periphery of each VAWT overlaps, so that VAWT blades mesh in said "blade return" region behind said diverter shield (1).
- 5
8. The wind turbine system according to one of the preceding claims, wherein a generator (3) is driven by at least one VAWT (2).
9. The wind turbine system according to claim 8, wherein said generator (3, 3D) is a DC generator.
- 10
10. The wind turbine system according to claim 9, wherein the DC generator (3, 3D) is connected to a DC battery system (6).
11. The wind turbine system according to claim 10, wherein the DC battery system (6) is a DC battery system (6, 6S) of a solar panel power plant.
- 15
12. The wind turbine system according to one of the preceding claims, wherein each VAWT (2) is connected to each its electrical generator (3, 32).
- 20
13. The wind turbine system according to one of the preceding claims, wherein each VAWT (2) is connected to a common electrical generator (3, 31).
14. The wind turbine system according to claim 9, wherein each VAWT (2) drives a respective part of a contra rotating generator (3, 30).
- 25
15. The wind turbine system according to one of the preceding claims, wherein each VAWT (2) is a Darrieus wind turbine.
16. The wind turbine according to one of the preceding claims, wherein the wind turbine blades (23a, 23b, 23c) of the pair of counter rotating VAWTs (23) are helical.
- 30
17. The wind turbine according to claim 16, wherein the helical wind turbine blades (23a, 23b, 23c) are oppositely directed on a right VAWT (2R) relative to a left VAWT (2L).
- 35

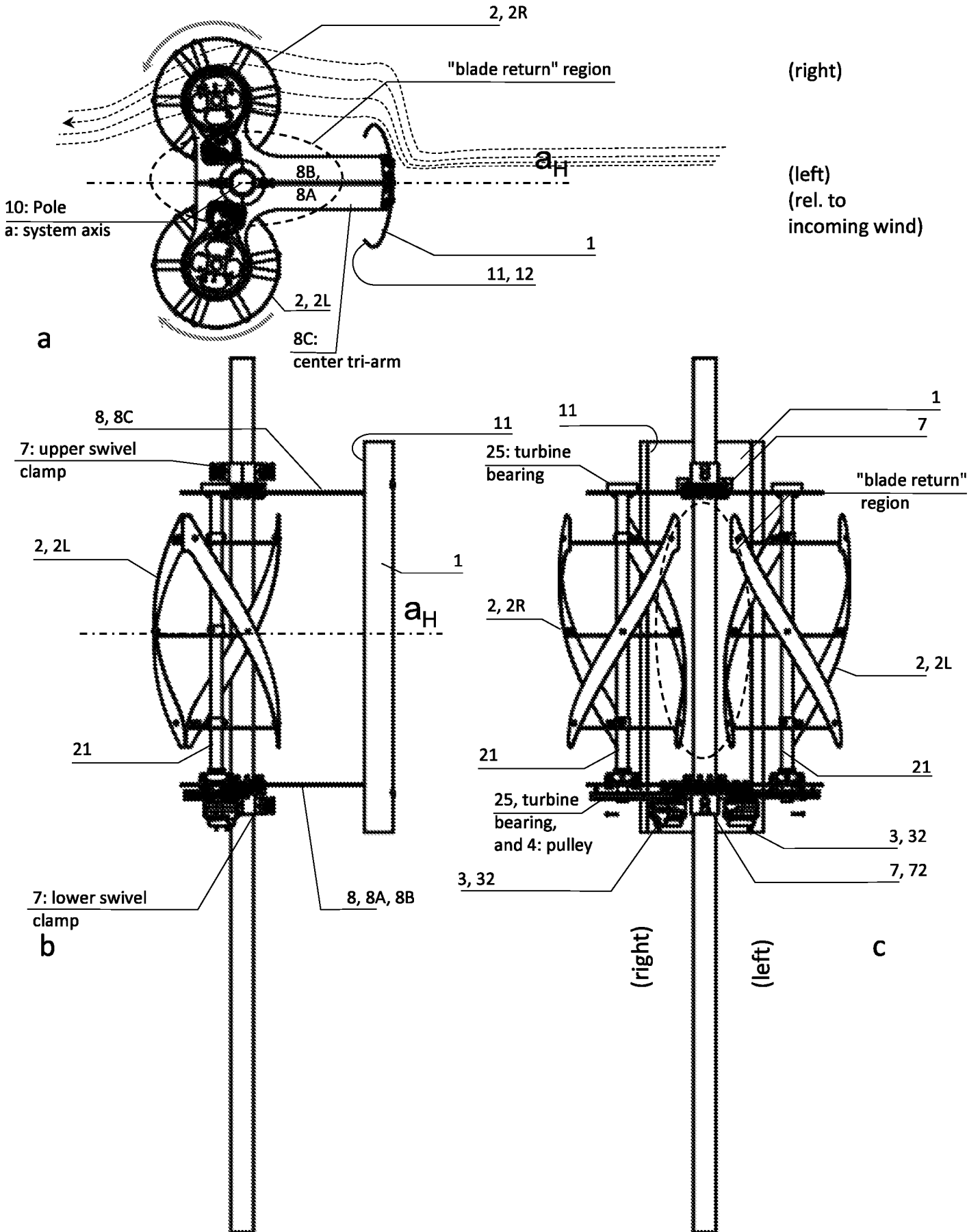
18. The wind turbine system according to one of claims 8 - 14, wherein each VAWT (2) is provided with a pulley (4) and a belt (5) for driving the generator (3).
- 5 19. The wind turbine system according to claim 18, wherein each VAWT (2) is provided with a flywheel (4, 4F) for rotational inertia stability.
20. The wind turbine system according to claim 19, wherein said flywheel is constituted by said pulley.
- 10 21. The wind turbine system according to one of the preceding claims, wherein said right and left VAWTs (2, 2R, 2L) and said diverter shield (1) are mounted swivelling about said pole on two or more split swivel clamps (7) with a first and a second half clamp (7A, 7B), said swivel clamps (7) arranged in two different
- 15 elevation levels of said pole (10).
22. The wind turbine system according to claim 21, wherein one or more of said swivel clamps having at least one split electrical slip ring (72, 72A, 72B) connection from an output of a generator (3).
- 20 23. The wind turbine system according to claim 21, provided with right and left half tri-lobe pole mounting plates (8A, 8B) with the split swivel clamps (7, 7A, 7B) and bearings (81R, 81L) for turbine axles (22) and bracket (83) for the diverter shield (1).
- 25 24. The wind turbine system of any of the preceding claims, wherein the pair of counter rotating VAWTs (2) are synchronized in rotation.
25. **A method** of assembling a wind turbine system, comprising the steps of
- 30 i) assemble and fix a lower swivel clamp (7) halves (7A, 7B) about a lower attachment level on a pole, assemble split axial bearing ring (76) halves (76A, 76B) on top of said lower swivel clamp (7),
- ii) assemble an upper swivel clamp (7) about the pole and attach it temporarily just above an upper attachment level on the pole,
- 35 iii) assemble right and left vertical axis wind turbines (VAWTs) (2, 2A, 2B) in upper and lower turbine bearings (25) on right and left, upper and lower tri-arm plate halves (8A, 8B),

- iv) join said right and left lower tri-arm plate halves (8 8A, 8B) and join said right and left upper tri-arm plate halves (8, 8A, 8B) about the pole, forming complete upper and lower tri-arm plates (8) now holding said right and left VAWTs (2),
- 5           - bolt join said first and left tri-arm plate halves (8A, 8B) by  
          - using a first and second split plate coupling ring (71A, 71B) at a proximal side of each tri-arm plate (8) and  
          - using a first and second split plate coupling ring (71A, 71B) and a split plate flange bearing ring (77A, 77B)
- 10 v) mount the diverter shield (1) on aligned upper and lower center arms (8C) of the assembled tri-arm plates (8),  
          - mount said diverter shield (1) on shield brackets (83) on center arms (8C),
- vi) lower the assembled lower tri-arm plate (8) down onto the lower swivel clamp (7), now supporting the assembled VAWTs (2, 2A, 2B) with the diverter shield (1)
- 15           - land the assembled lower tri-arm plate (8) on the assembled split axial bearing ring (76) on top of said lower swivel clamp (7),
- vii) lock an upper part of an electrical slip ring to the lower tri-arm plate and connect to a generator (3),
- viii) lock a lower part of the electrical slip ring to the lower swivel clamp (7) and  
20 connect to a voltage receiving device (6),
- ix) lower the upper swivel clamp (7) down onto the upper tri-arm plate (8), and fix the upper swivel clamp (7) at the upper attachment level on the pole.

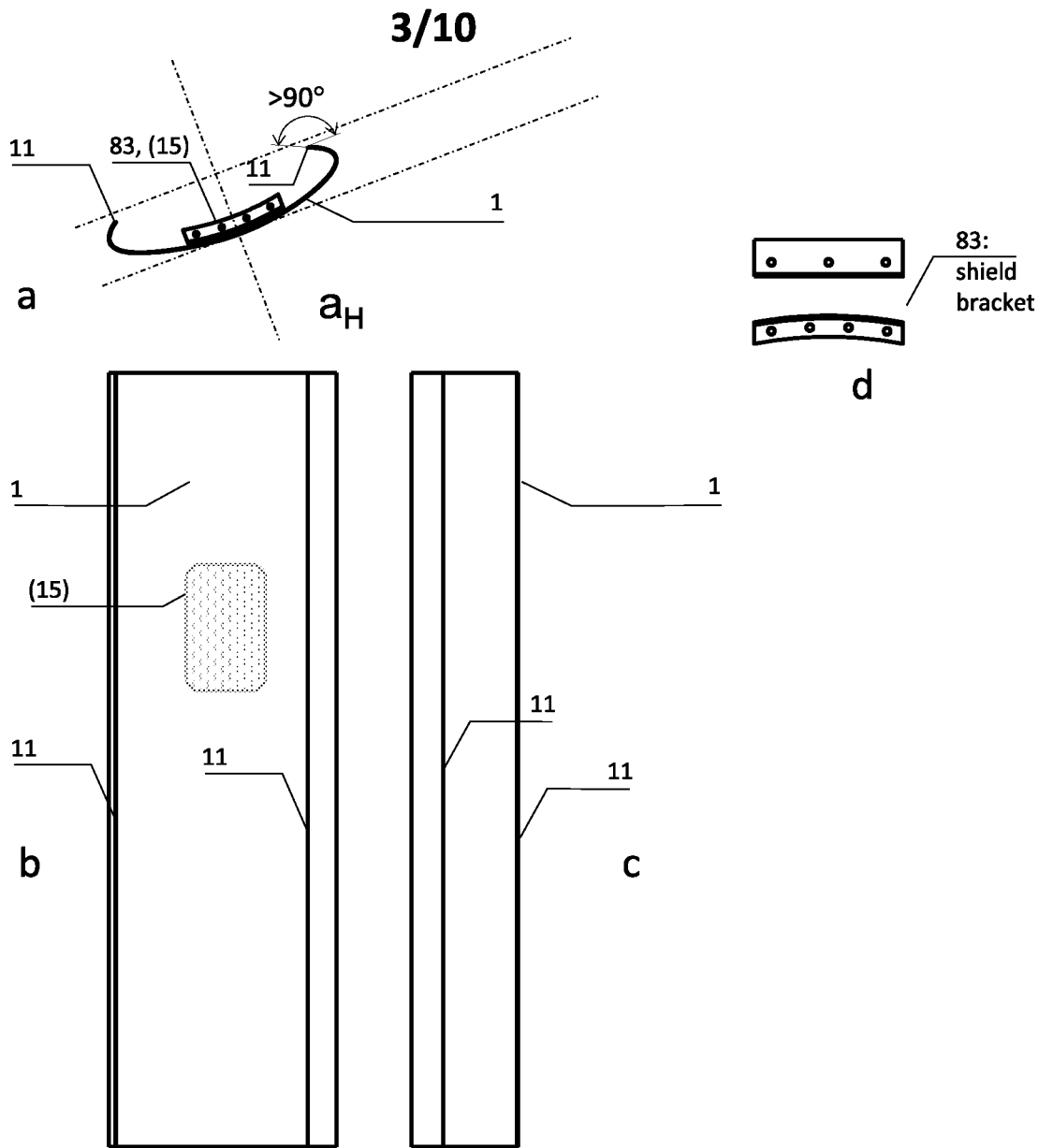


**Fig. 1:** assembled wind turbine system with contra rotating Darrieus helical wind turbines arranged on a pole structure, and incoming wind direction

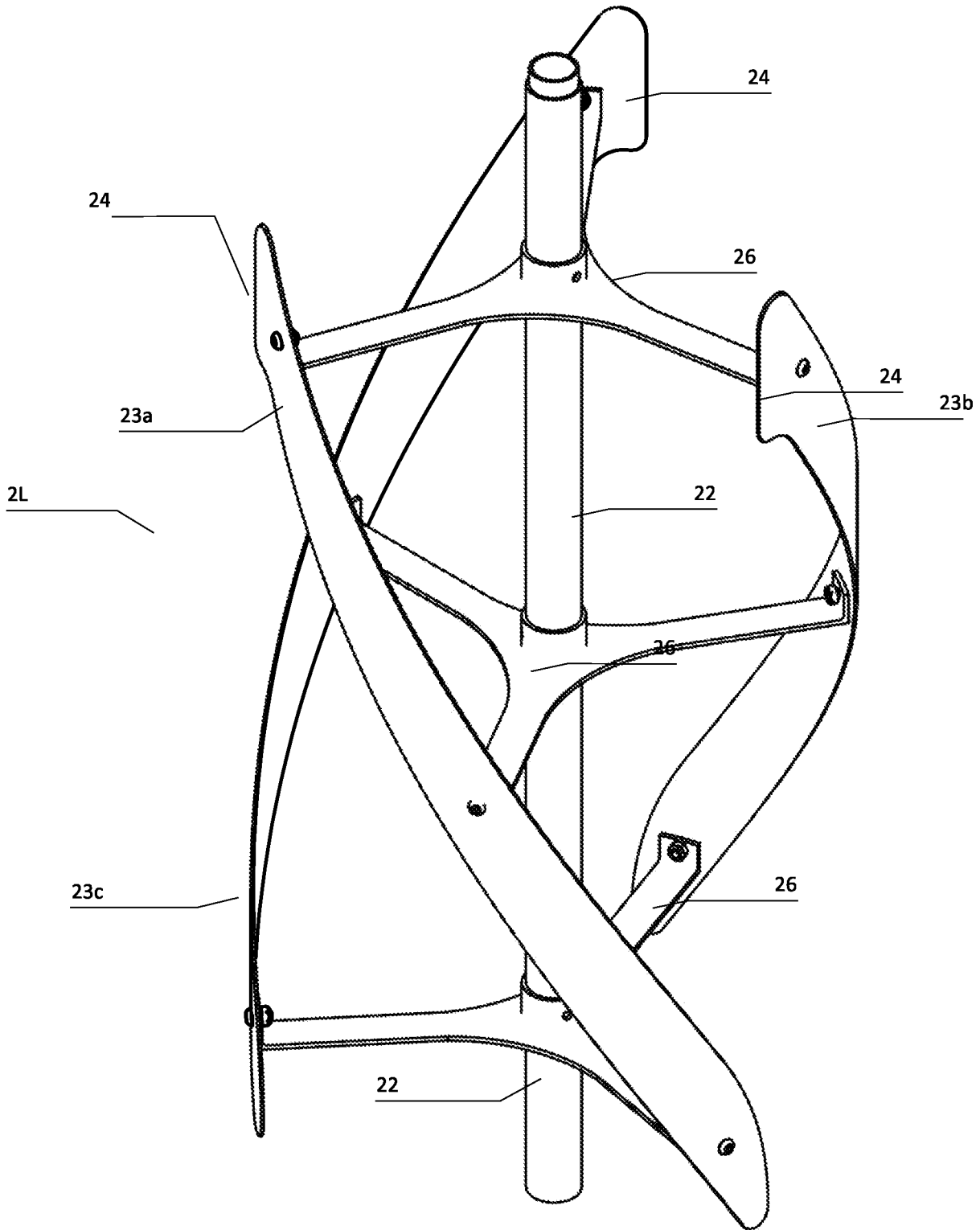
2/10



**Fig. 2:** top transarent view and lateral views of the assembled wind turbine system arranged on a pole structure

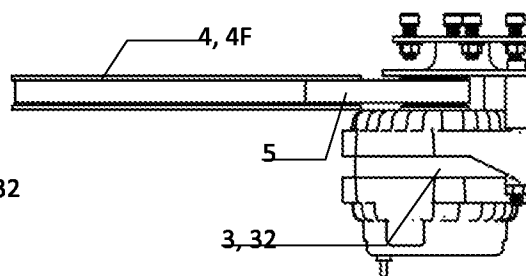
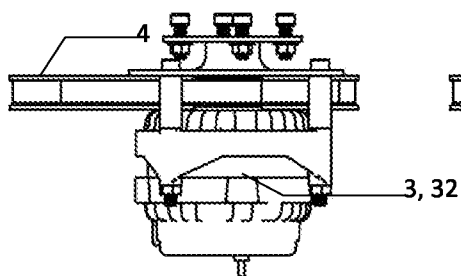
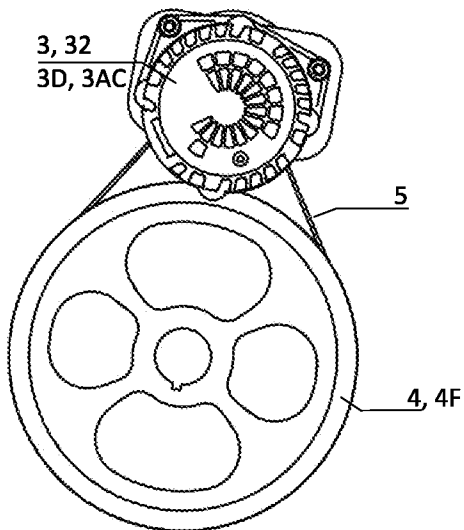
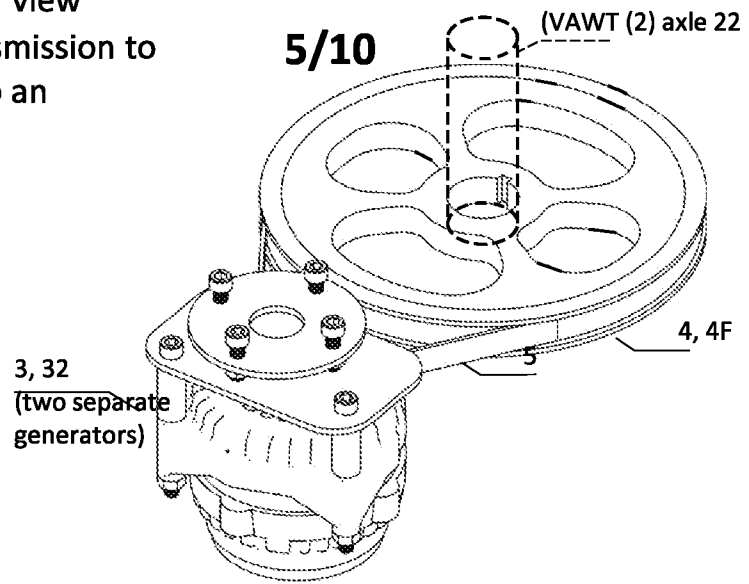


**Fig. 3:** top view and lateral views of the diverter shield (1) and shield mounting bracket.

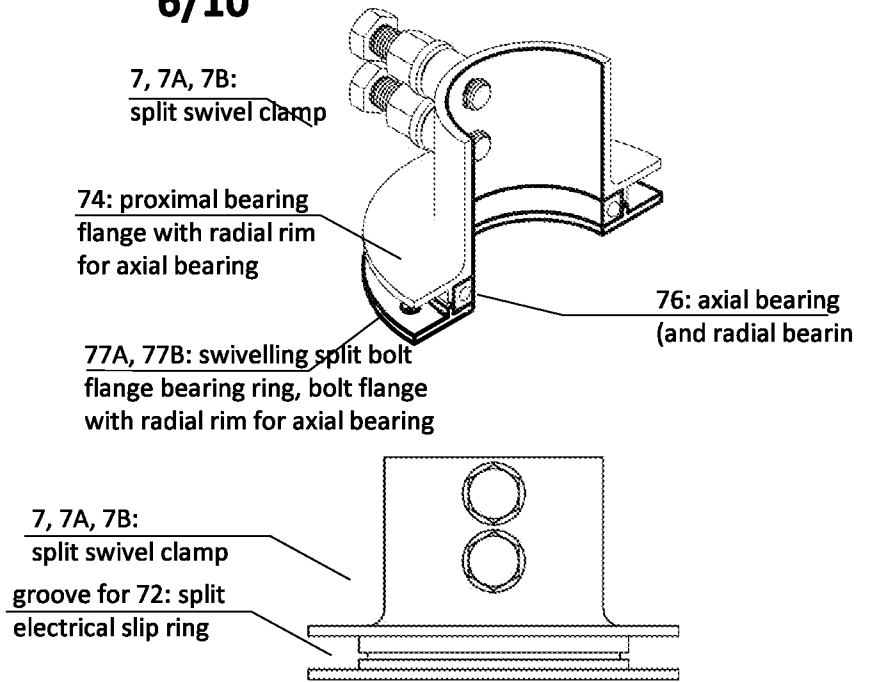
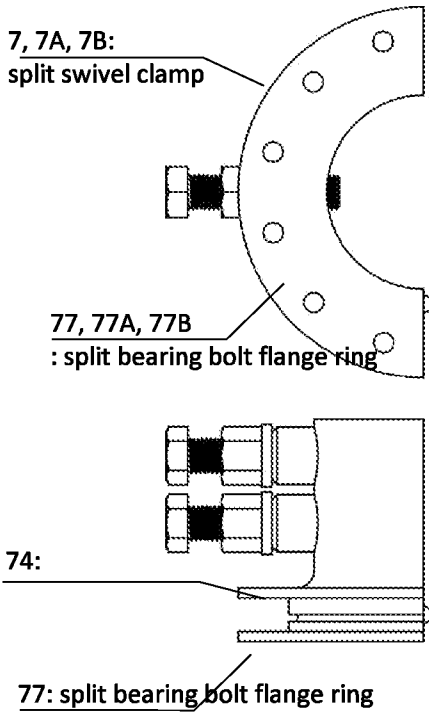


**Fig. 4:** isometric "perspective" view of a wind turbine (2) of an embodiment of the invention , a Darrieus turbine with helical blades.

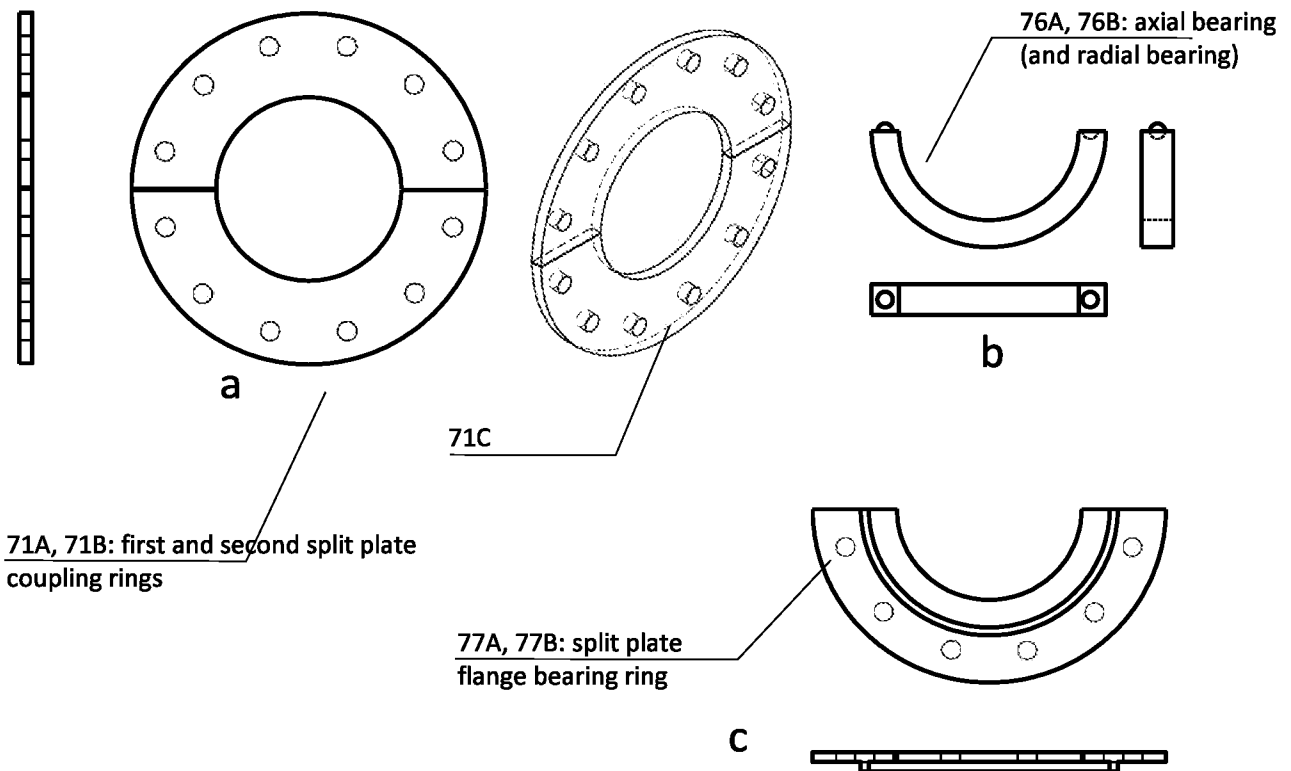
**Fig. 5:** isometric "perspective" view of a pulley (4) and belt (5) transmission to a generator (3, 32) according to an embodiment of the invention.



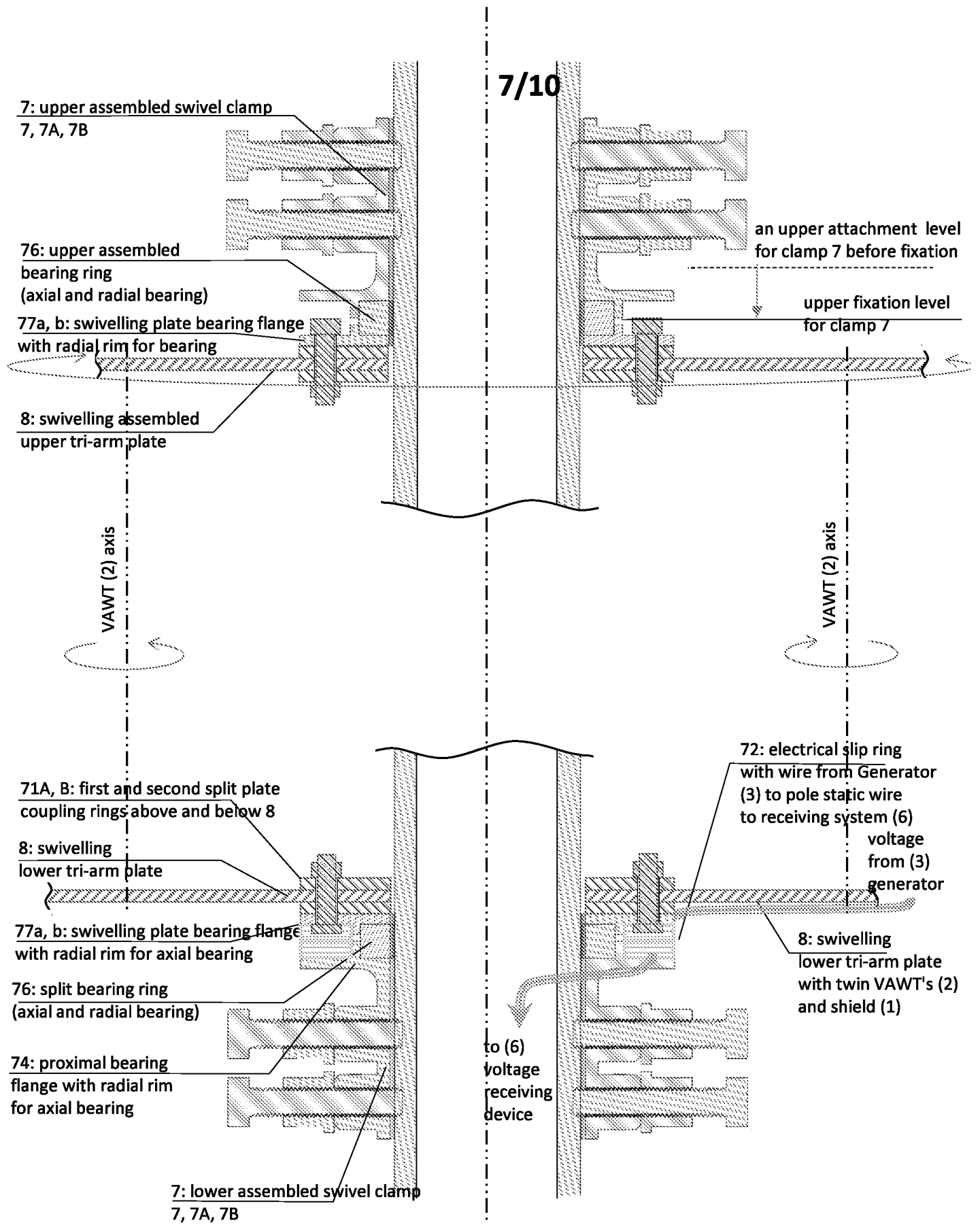
**Fig. 6:** bottom view and elevation views of the pulley and belt transmission to the dynamo according to an embodiment of the invention



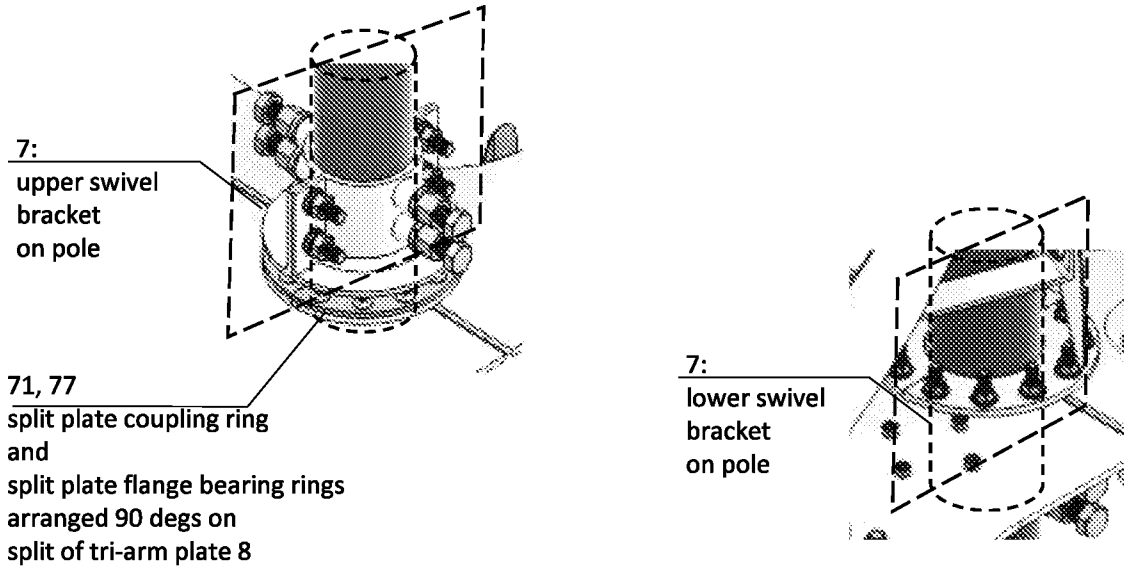
**Fig. 7A:** bottom view and elevation views of part assembled split swivel clamp , split bearing ring (72) and split bearing clamp ring



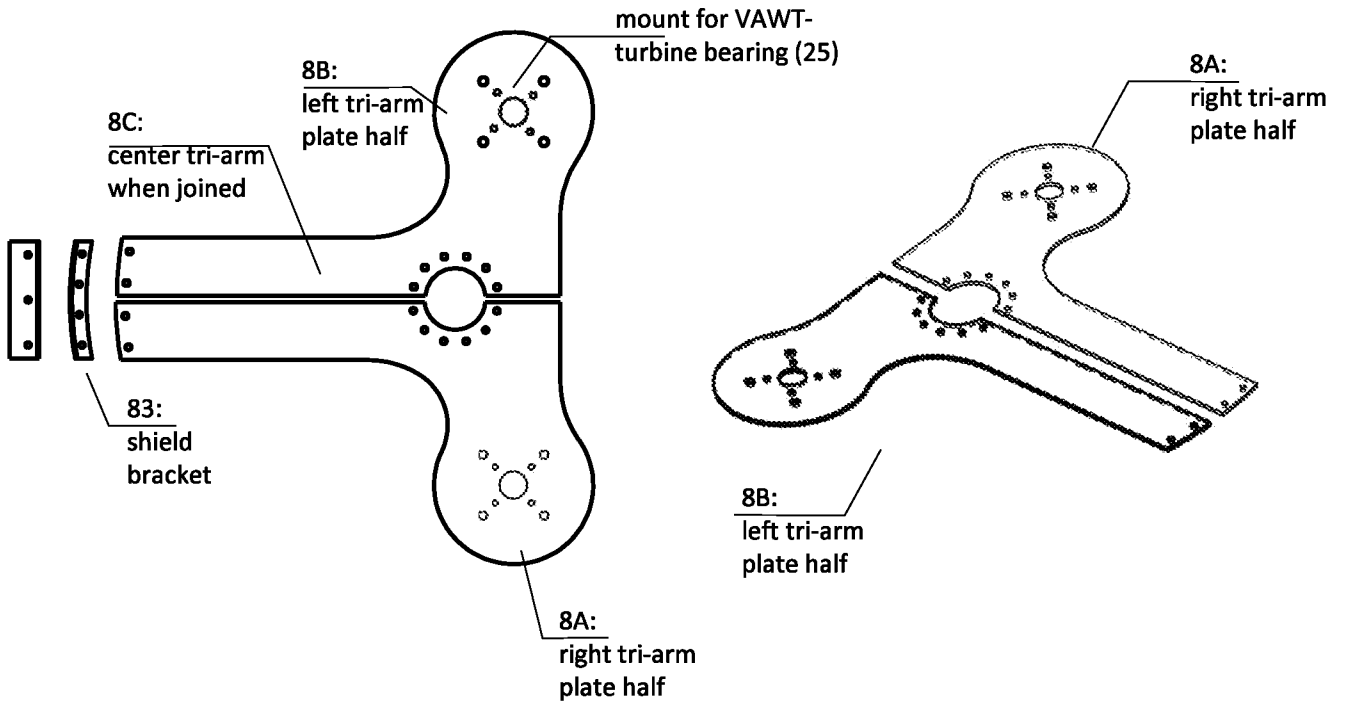
**Fig. 8:** lateral and axial view and perspective views of the split plate coupling ring according to an embodiment of the invention, this is mounted 90 degs to the split in the plate (8), together with with the swivel clamp (7) also turned 90 degs.



**Fig. 7B:** assembled upper and lower split swivel clamps holding according to an embodiment of the invention, vertical section view.



**Fig. 7C:** assembled upper and lower split swivel clamps with joined tri-arms assembled onto, isometric view with section plane for Fig. 7B,



**Fig. 7D:** upper and lower tri-arms plane view with shield bracket, and isometric view, before assembly

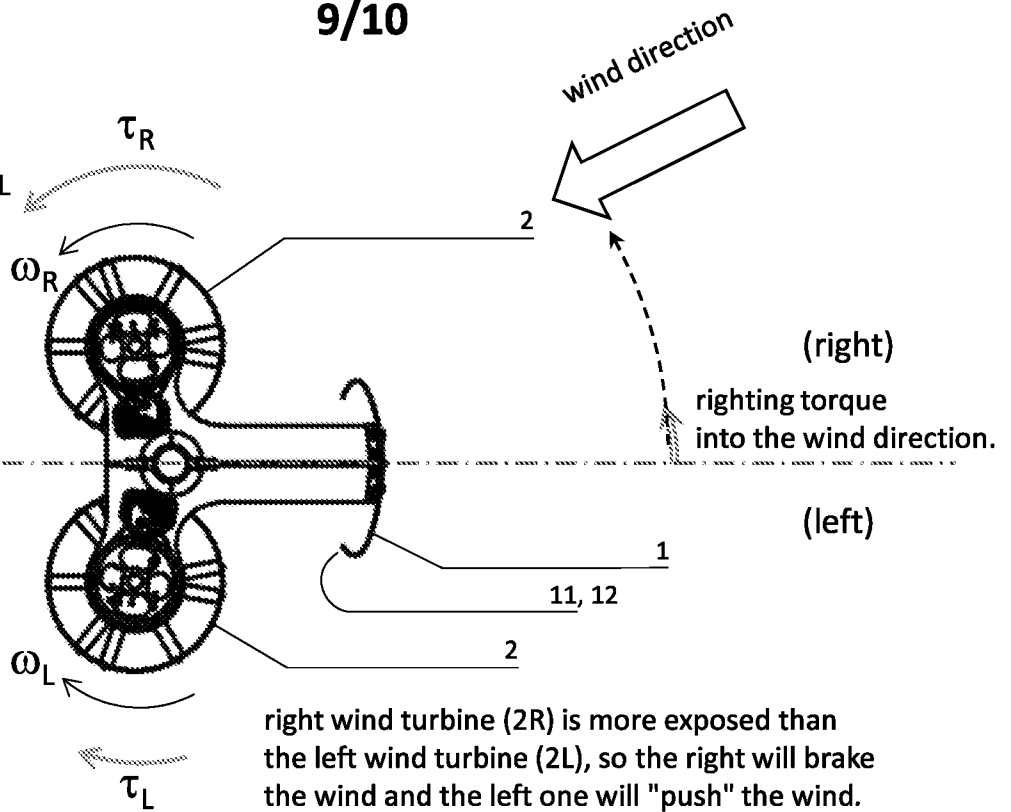
synchronized or near equal

rotational speed:  $\omega_R = \omega_L$

righting torque

$\tau_{sum}$

$\tau_{sum} = \tau_R - \tau_L$

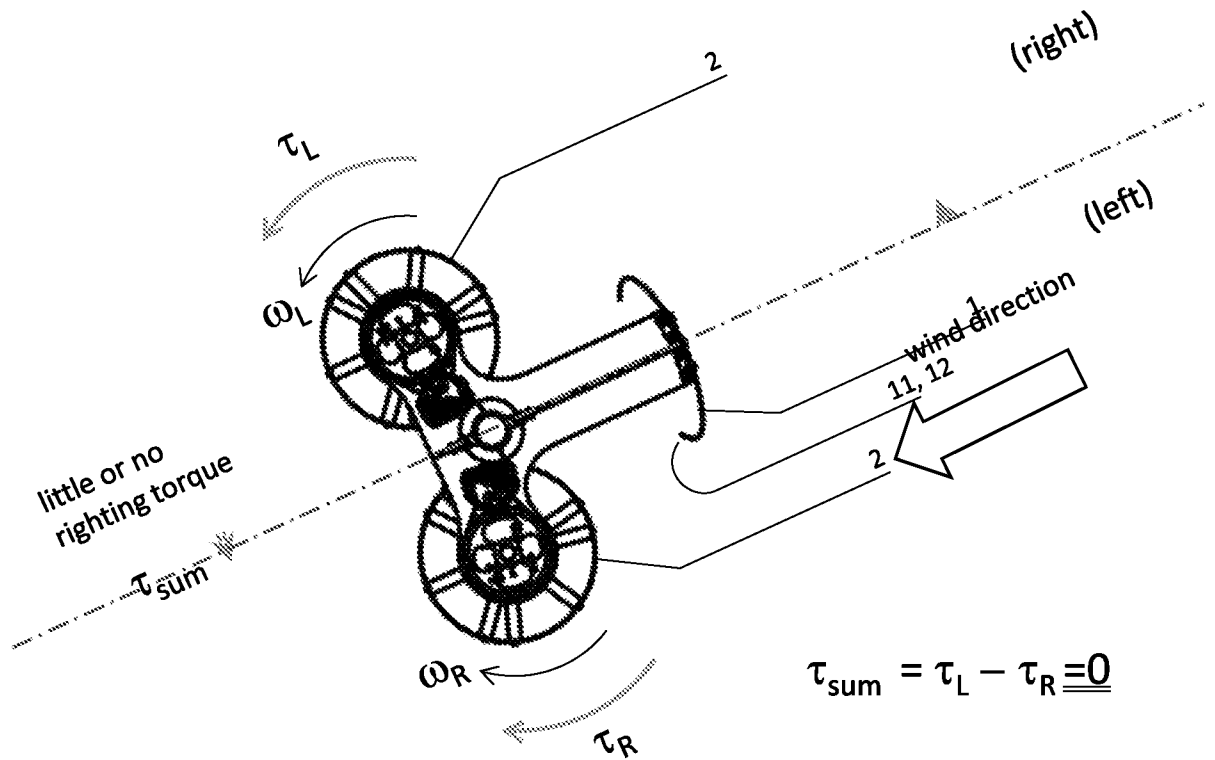


right wind turbine (2R) is more exposed than the left wind turbine (2L), so the right will brake the wind and the left one will "push" the wind.

$\tau_R > \tau_L$

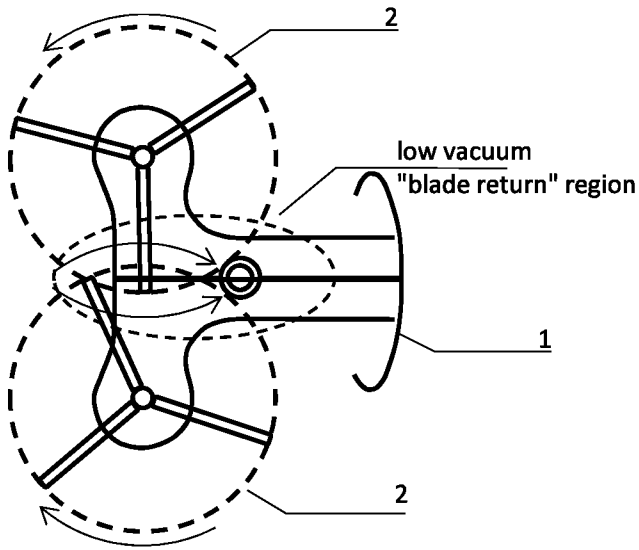
and set up a relatively weak righting torque

$\tau_{sum} = \tau_R - \tau_L$

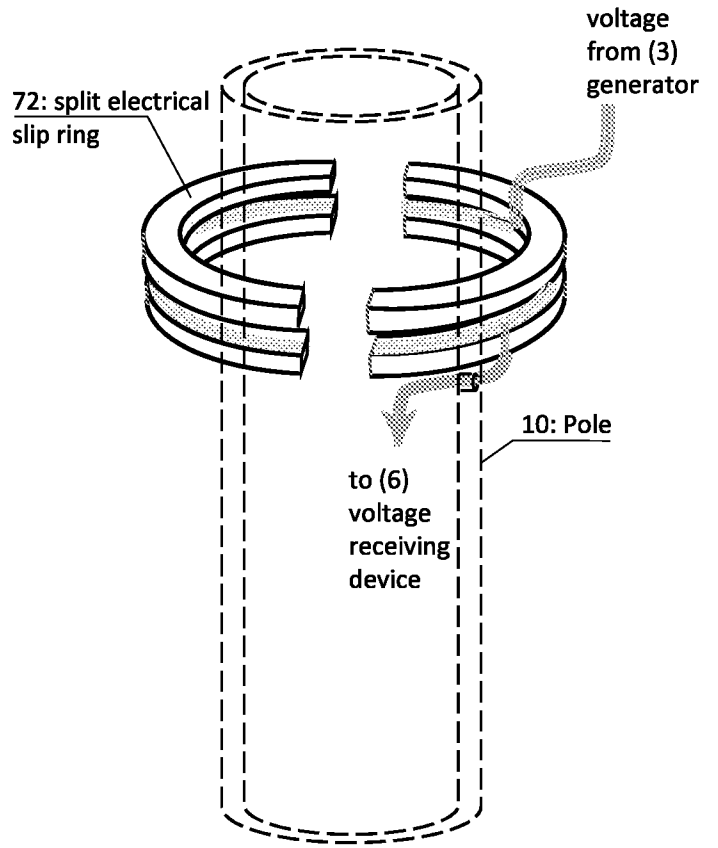


$\tau_{sum} = \tau_L - \tau_R \equiv 0$

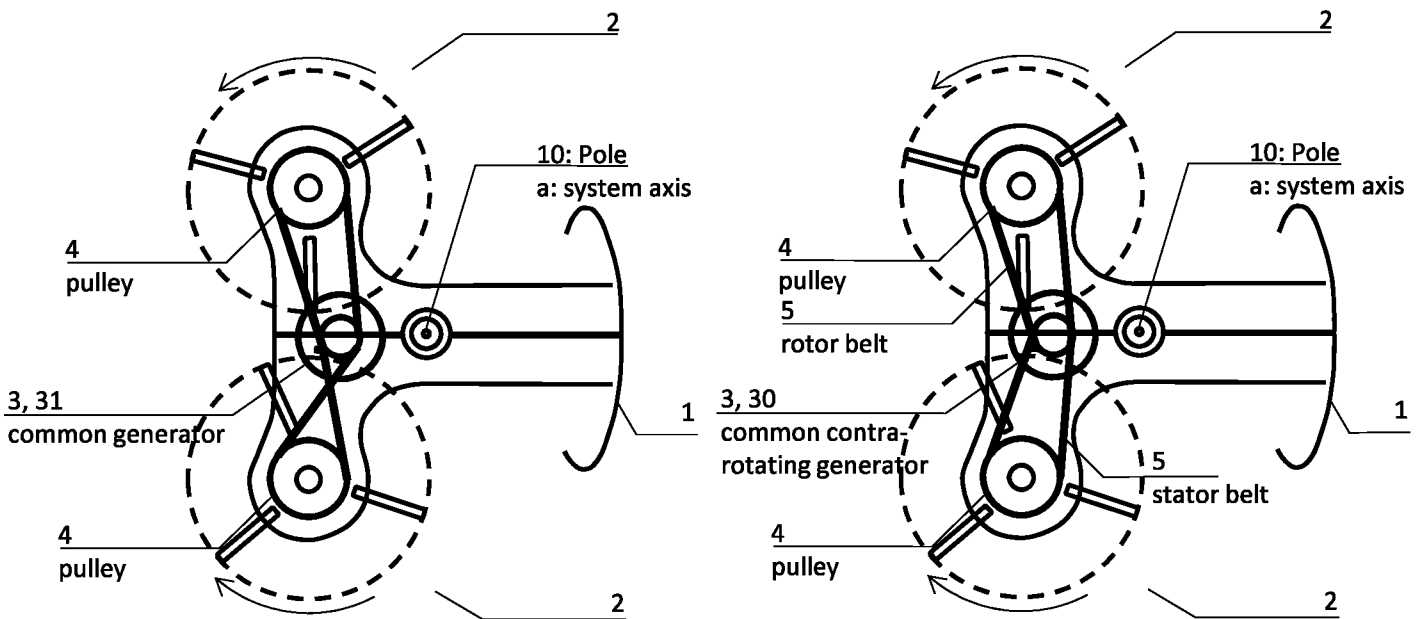
**Fig. 9:** top view of wind generated torques when the wind direction is to the right, creating a righting torque into the wind direction.



**Fig. 10:** top view of synchronized rotation, meshed blades (23) of VAWT's (2)



**Fig. 12:** principle sketch of split electrical swivel



**Fig. 11:** principle sketch of common generator of two VAWT's (2). Both belts to common rotor axle (left) and to counter-rotating generator (right) .