

(12) STANDARD PATENT
(19) AUSTRALIAN PATENT OFFICE

(11) Application No. **AU 2017268564 B2**

(54) Title
INDOOR UNIT OF AIR CONDITIONER AND METHOD FOR ASSEMBLING INDOOR UNIT OF AIR CONDITIONER

(51) International Patent Classification(s)
F24F 1/00 (2011.01)

(21) Application No: **2017268564** (22) Date of Filing: **2017.11.29**

(30) Priority Data

(31) Number	(32) Date	(33) Country
2016-232895	2016.11.30	JP

(43) Publication Date: **2018.06.14**

(43) Publication Journal Date: **2018.06.14**

(44) Accepted Journal Date: **2019.07.04**

(71) Applicant(s)
Mitsubishi Heavy Industries Thermal Systems, Ltd.

(72) Inventor(s)
Higashiura, Kunihiro;Okamura, Kazumi;Kanbara, Hiroshi;Yamaguchi, Tomomitsu;Hisamatsu, Shion

(74) Agent / Attorney
Phillips Ormonde Fitzpatrick, PO Box 323, Collins Street West, VIC, 8007, AU

(56) Related Art
US 2011/0211944 A1
JP H1183070 A

ABSTRACT OF THE DISCLOSURE

An indoor unit of an air conditioner includes a housing; a blowing fan and a heat exchanger accommodated in the housing; a blowout port (15) extending in a horizontal direction (D1) and provided in a lower portion of the housing to blow air from the blowing fan into a room; a fixing portion (25) provided to cross the blowout port (15); a groove portion (26) provided in the fixing portion (25) to be recessed from an end portion on a downstream side of the air flow toward an upstream side; a protective member (20) which is disposed on the downstream side of the fixing portion (25), covers the blowout port (15) to allow ventilation, and has a horizontal rail (21) capable of being inserted into the groove portion (26); and a locking member (30) which is locked to the fixing portion (25) from the downstream side of the protective member (20) to restrict movement of the horizontal rail (21) inserted into the groove portion (26).

INDOOR UNIT OF AIR CONDITIONER AND METHOD FOR ASSEMBLING
INDOOR UNIT OF AIR CONDITIONER

This application claims priority from Japanese Application No. 2016-232895 filed on 30
5 November 2016, the contents of which are to be taken as incorporated herein by this
reference.

BACKGROUND OF THE INVENTION

Field of the Invention

10 [0001]

The present invention relates to an indoor unit of an air conditioner and a
method for assembling the indoor unit.

Description of Related Art

15 [0002]

In the related art, an indoor unit of an air conditioner in which a blowout port for
blowing air from a blowing fan into a room is covered with a protective member such as
a fan guard capable of ventilation to prevent a contact to the blowing fan has been known.
Such a protective member is disclosed in, for example, Patent Document 1. The fan
20 guard (protective member) disclosed in Patent Document 1 is mounted to a left and right
wind direction plate bases that support left and right wind direction plates for changing
the wind direction.

[0003]

As a conventional protective member, for example, a structure in which a
25 plurality of holes penetrating in a horizontal direction are provided in a pillar vertically
bridging a blowout port and a plurality of rod-like members are inserted and assembled

through the holes has been known.

[0004]

[Patent Documents]

[Patent Document 1] Japanese Unexamined Patent Application, First

5 Publication No. 2005-188871

[0005]

However, in the conventional indoor unit disclosed in Patent Document 1, after the protective member is mounted to another member such as the left and right wind direction plate bases, another member to which the protective member is mounted is
10 installed at the blowout port. Therefore, the number of working steps for assembling increases, and there is a problem that labor is required for assembling the protective member.

Further, even in the case of a structure in which a rod-like member is inserted into the hole penetrating the pillar to constitute the protective member, it is necessary to
15 insert the rod-like members into the holes of the pillar one by one. Therefore, even in the case of such a structure, there is a problem in that it takes labor to assemble the protective member.

[0006]

Accordingly, at least some embodiments of the present invention provide an
20 indoor unit of an air conditioner in which it is possible to directly assemble a protective member covering a blowout port to allow ventilation directly to the blowout port and in which assembling properties of the protective member can be improved, and a method for assembling the indoor unit.

[0006a]

25 Any reference herein to a patent document or other matter which is given as

prior art is not to be taken as an admission that that document or matter was known or that the information it contains was part of the common general knowledge as at the priority date of any of the claims.

[0006b]

5 Throughout the description and claims of the specification, the word “comprise” and variations of the word, such as “comprising” and “comprises”, is not intended to exclude other additives, components, integers or steps.

SUMMARY OF THE INVENTION

10 [0007]

According to a first aspect, the present invention provides an indoor unit of an air conditioner comprising: a housing; a blowing fan and a heat exchanger accommodated in the housing; a blowout port extending in a horizontal direction and provided in a lower portion of the housing to blow air from the blowing fan into a room;

15 a fixing portion provided to cross the blowout port; a groove portion provided in the fixing portion to be recessed from an end portion on a downstream side of the air flow toward an upstream side; a protective member which is disposed on the downstream side of the fixing portion, covers the blowout port to allow ventilation, and has a rail capable of being inserted into the groove portion; and a locking member which is locked to the

20 fixing portion from the downstream side of the protective member to restrict movement of the rail inserted into the groove portion, wherein the protective member has a plurality of rod-like horizontal rails having elasticity, as the rail, the plurality of rod-like horizontal rails extending in the horizontal direction and disposed to be spaced apart from each other in a vertical direction intersecting with the horizontal direction, wherein the

25 protective member further has a rod-like vertical rail which is disposed to extend in the

vertical direction at a position of a louver provided at the blowout port so as to extend in the vertical direction, and connects and fixes the plurality of horizontal rails in the vertical direction at predetermined intervals, wherein the groove portion includes a reduction portion having a pair of inclined guide surfaces in which a width gradually
5 decreases from the downstream side toward the upstream side; and an expanded accommodating portion provided to be wider than the reduction portion on the upstream side of the reduction portion and capable of locking and accommodating the two adjacent horizontal rails, and wherein the groove width dimension of the expanded
10 accommodating portion in the vertical direction is formed to be the same as the dimension obtained by adding the interval between the two adjacent horizontal rails accommodated in the expanded accommodating portion and the width of the two horizontal rails.

[0008]

According to such an indoor unit, the groove portion recessed from the
15 downstream side to the upstream side is provided in the fixing portion provided in the blowout port, and the rail of the protective member can be inserted into the groove portion. Therefore, by disposing the protective member covering the blowout port to allow ventilation at the downstream side of the blowout port, and by inserting the rail
20 into the groove portion of the fixing portion from the downstream side of the blowout port, the protective member can be easily directly disposed at a predetermined position on the downstream side of the blowout port.

Further, the locking member can be locked to the fixing portion from the downstream side of the protective member to restrict the movement of the rail inserted into the groove portion. For this reason, in the state in which the protective member is

disposed on the downstream side of the blowout port and the rail is inserted into the groove portion, by locking the locking member to the fixing portion, the protective member can be easily supported by the blowout port.

[0009]

5 In the indoor unit of the air conditioner according to a second aspect of the present invention, in the first aspect, the protective member may have a plurality of rod-like horizontal rails having elasticity, as the rail, the plurality of rod-like horizontal rails extending in the horizontal direction and disposed to be spaced apart from each other in a vertical direction intersecting with the horizontal direction, and the protective
10 member may further have a rod-like vertical rail which is disposed to extend in the vertical direction at a position of a louver provided at the blowout port so as to extend in the vertical direction, and connects and fixes the plurality of horizontal rails.

[0010]

 In this way, when a plurality of horizontal rails are connected and fixed by the
15 vertical rail, the plurality of horizontal rails are disposed at predetermined intervals and are moderately elastically deformable. Therefore, it is possible to insert the horizontal rail into the groove portion of the fixing portion, while moderately elastically deforming the horizontal rail, and it is possible to improve workability at the time of mounting the protective member.

20 Moreover, since the vertical rail is disposed at the position of the louver of the blowout port, the vertical rail does not hinder the flow of air from the blowing fan and then blown out of the blowout port.

[0011]

 Further, in the indoor unit of the air conditioner according to a third aspect of the
25 present invention, in the second aspect, the vertical rail may be disposed on the upstream

side of the horizontal rail.

In such an indoor unit of the air conditioner, since the vertical rail is not disposed on the outer side (downstream side) of the horizontal rail, it is possible to suppress the protruding portion of the protective member to the outer side to be small, and to improve the aesthetic appearance.

[0012]

In the indoor unit of the air conditioner according to a fourth aspect of the present invention, in any one of the first to third aspects, the fixing portion may be a pillar which extends in a vertical direction intersecting with the horizontal direction at the blowout port to reinforce the blowout port.

[0013]

In such an indoor unit, the protective member can be mounted using a pillar for reinforcing the blowout port. Therefore, since it is not necessary to separately provide a fixing member, complication of the structure of the blowout port can be suppressed and it becomes difficult to inhibit the flow of the air blown out of the blowout port.

[0014]

In the indoor unit of the air conditioner according to a fifth aspect of the present invention, in the first to fourth aspects, the groove portion may further have a reduction portion having a pair of inclined guide surfaces in which a width gradually decreases from the downstream side toward the upstream side; and an expanded accommodating portion provided to be wider than the reduction portion on the upstream side of the reduction portion and capable of locking and accommodating the rail.

In such an indoor unit, when the protective member is inserted from the downstream side, since the plurality of horizontal rails are gradually elastically deformed and moved by the inclined guide surface, and thereafter, the plurality of horizontal rails

are restored by the expanded accommodating portion to enlarge the interval, the plurality of horizontal rails are accommodated and stably disposed in the expanded accommodating portion. Therefore, the assembling property of the protective member can be further improved.

5 [0015]

According to another aspect, the present invention provides a method for assembling an indoor unit of an air conditioner, the method comprising: providing a fixing portion in a vertical direction intersecting with a horizontal direction, at a blowout port extending in the horizontal direction and provided in a lower portion of a housing to
10 blow air from a blowing fan into a room, and providing a groove portion in the fixing portion to be recessed from an end portion on a downstream side of a flow of air toward an upstream side; disposing a protective member configured to cover the blowout port to allow the ventilation on the downstream side of the fixing portion and inserting a rail of the protective member from the downstream side into the groove portion; and locking the
15 locking member to the fixing portion from the downstream side of the protective member to restrict movement of the rail inserted into the groove portion, wherein the protective member includes a plurality of rod-like horizontal rails having elasticity, extending in the horizontal direction and disposed to be spaced apart from each other in a vertical direction intersecting with the horizontal direction, wherein the protective member
20 further has a rod-like vertical rail which is disposed to extend in the vertical direction, and connects and fixes the plurality of horizontal rails at predetermined intervals, wherein the groove portion includes a reduction portion having a pair of inclined guide surfaces in which a width gradually decreases from the downstream side toward the upstream side; and an expanded accommodating portion provided to be wider than the
25 reduction portion on the upstream side of the reduction portion and capable of locking

and accommodating the two adjacent horizontal rails, and wherein the groove width dimension of the expanded accommodating portion in the vertical direction is formed to be the same as the dimension obtained by adding the interval between the two adjacent horizontal rails accommodated in the expanded accommodating portion and the width of the two horizontal rails.

[0016]

According to such a method for assembling the indoor unit, the fixing portion is provided in the middle of the blowout port, the groove portion recessed from the downstream side toward the upstream side is provided in the fixing portion, the protective member is disposed on the downstream side of the fixing portion, and the rail of the protective member is inserted into the groove portion. Therefore, the protective member covering the blowout port to allow ventilation can be easily directly disposed at a predetermined position on the downstream side of the blowout port.

Further, the locking member is locked to the fixing portion from the downstream

side of the protective member to restrict the movement of the rail inserted in the groove portion. Therefore, the protective member disposed at a predetermined position on the downstream side of the blowout port can be easily installed in the blowout port.

[0017]

5 According to the indoor unit of the air conditioner and the method for assembling the indoor unit of the air conditioner, the protective member covering the blowout port to allow ventilation can be directly assembled to the blowout port, thus the assembling property of the protective member can be improved.

10

BRIEF DESCRIPTION OF THE DRAWINGS

[0018]

FIG. 1 is a transverse cross-sectional view of an indoor unit of an air conditioner according to an embodiment of the present invention.

15 FIGS. 2A and 2B are perspective views showing a part of a protective member in an indoor unit according to an embodiment of the present invention, FIG. 2A shown a general overview, and FIG. 2B shown an enlarged view of a part X of FIG. 2A.

FIG. 3 is a partially enlarged view showing a mounted state of the protective member in the indoor unit according to an embodiment of the present invention.

20 FIG. 4 is a partial side view for explaining the locked state of the protective member and a locking member with respect to a fixing portion in the indoor unit according to the embodiment of the present invention.

FIG. 5 is a partial cross-sectional view of the fixing portion and the locking member for explaining the locked state of the locking member with respect to the fixing portion in the indoor unit according to the embodiment of the present invention.

25 FIG. 6 is a flowchart showing a procedure of a method for assembling the

indoor unit according to an embodiment of the present invention.

DETAILED DESCRIPTION OF THE INVENTION

[0019]

5 An air conditioner 100 includes an indoor unit 10 provided in a room, and an outdoor unit (not shown) connected to the indoor unit 10 by piping and provided outside.

The indoor unit 10 suctions air, adjusts the temperature and humidity, and then blows out air to perform indoor air conditioning.

Hereinafter, the indoor unit 10 according to the embodiment of the present
10 invention will be described.

[0020]

As shown in FIG. 1, the indoor unit 10 is formed in a horizontally elongated shape extending in a horizontal direction D1 (a direction orthogonal to the sheet). The indoor unit 10 includes a housing 11, a blowing fan 14 and a heat exchanger 13
15 accommodated inside the housing 11, and a blowout port 15 provided in a lower portion of the housing 11 and extending in the horizontal direction D1.

[0021]

Further, for the purpose of preventing a contact to the blowing fan 14, the indoor unit 10 further includes a protective member 20 which covers the entire opening end 15a
20 of the blowout port 15 to allow ventilation, a fixing portion 25 which fixes the protective member 20, a groove portion 26 which is provided in the fixing portion 25 and into which the protective member 20 can be inserted, and a locking member 30 which is locked to the fixing portion 25 in a state in which the protective member 20 is inserted into the groove portion 26.

25 [0022]

The housing 11 has a substantially rectangular parallelepiped shape and can accommodate various components.

The blowing fan 14 is a cross flow fan that extends in the horizontal direction D1.

5 The heat exchanger 13 is provided to surround the blowing fan 14 from the outer circumference.

[0023]

As the blowout port 15, a horizontally long blowout port 15 for blowing air from the blowing fan 14 into the room is opened downward, diagonally downward, or forward.

10 As shown in FIGS. 1 and 2, a louver 17 for adjusting the wind direction to the left and right is provided on a side closer to an upstream side of the flow of air A blown out of the blowout port 15 than the opening end 15a. In the louver 17, a plurality of vanes 17a along a vertical direction D2 intersecting with the horizontal direction D1 are disposed at intervals in the horizontal direction D1. Although it is not shown in detail, a flap 12 is
15 provided at the outside of the opening end 15a. The flap 12 closes the opening end 15a from the outer side at the time of stopping and turns outward at the time of operation to open the opening end 15a or adjust the wind direction up and down (see FIG. 1).

[0024]

As shown in FIG. 1, the protective member 20 is disposed between the louver 17
20 and the flap 12 on the downstream side of the blowout port 15. As shown in FIG. 2A, the protective member 20 is a member in which a plurality of horizontal rails (crosspieces) 21 extending in the horizontal direction D1 are coupled with a plurality of vertical rails 22 extending in the vertical direction D2 intersecting with the horizontal direction D. In the protective member 20, the plurality of horizontal rails 21 are
25 provided substantially in parallel in the vertical direction D2 at predetermined intervals,

the plurality of vertical rails 22 are provided substantially in parallel at predetermined intervals in the horizontal direction D1, and the plurality of horizontal rails 21 and the plurality of vertical rails 22 are orthogonal to each other and are connected and fixed at the intersections of the horizontal rails 21 and the vertical rails 22. Therefore, the protective member 20 is formed in a net shape (lattice shape) having a large number of openings surrounded by the horizontal rails 21 and the vertical rails 22. That is, since the protective member 20 is disposed in the blowout port 15, the protective member 20 is formed in a shape that does not hinder the flow of the air A.

[0025]

Further, each of the vertical rails 22 is disposed to extend in the vertical direction D2 at a position corresponding to each vane 17a of the louver 17. That is, when viewed from the downstream side, the vertical rail 22 is provided to overlap the end surface of the vane 17a. Further, as shown in FIG. 2B, the vertical rail 22 is disposed adjacent to the upstream side of the horizontal rail 21.

[0026]

The fixing portion 25 bridges between facing parts such as inner walls facing each other at the blowout port 15, and is provided to extend in the vertical direction D2.

The fixing portion 25 may be a pillar for reinforcing the blowout port 15 to prevent deformation, by bridging and being fixed between the facing parts. In the present embodiment, as shown in FIGS. 1 and 3, the fixing portion 25 is a pillar formed in a flat plate shape. The pillars are disposed at intervals in the horizontal direction D1 between the plurality of vanes 17a of the louver 17.

[0027]

As shown in FIGS. 3 to 5, the groove portion 26 is provided by being recessed in a notch shape from the end portion on the downstream side of the flow of the air A

blown out of the blowout port 15 toward the upstream side in the fixing portion 25. A plurality of groove portions 26 are provided in each fixing portion 25 (pillar) at intervals in the vertical direction D2. Further, the horizontal rails 21 of the protective member 20 can be inserted into the respective groove portions 26.

5 [0028]

As shown in FIG. 4, the groove portion 26 has a reduction portion 27 in which a groove width gradually reduces from the downstream end portion of the fixing portion 25 toward the upstream side, and an expanded accommodating portion 28 in which a groove width is widened in the vertical direction D2 and which is in communication with the
10 reduction portion 27 at the upstream side of the reduction portion 27.

[0029]

In the reduction portion 27 of a groove portion 26A located at the center in the vertical direction D2, the opening at the downstream end portion is formed to be wider than the dimension obtained by adding the interval between two adjacent horizontal rails
15 21 inserted into one reduction portion 27 and the width of these two horizontal rails 21. Further, the reduction portion 27 is formed by a pair of inclined guide surfaces 29. The interval of the facing inclined guide surfaces 29 in the vertical direction D2 is provided to gradually decrease from the opening of the groove portion 26A (reduction portion 27) and to become narrower than the width of the adjacent horizontal rail 21 at the inner
20 portion of the groove portion 26A.

In this reduction portion 27, the horizontal rail 21 can be elastically deformed so that, when the horizontal rails 21 move from the downstream side toward the upstream side, the interval between the adjacent horizontal rails 21 inserted into the same groove portion 26A becomes narrower due to the pair of inclined guide surfaces 29.

25 [0030]

The expanded accommodating portion 28 of the groove portion 26A located at the center in the vertical direction D2 has the dimension in the vertical direction D2 formed to be greater than the interval between the inclined guide surfaces 29 at the deepest part (the end portion on the most upstream side) of the reduction portion 27.

5 That is, the expanded accommodating portion 28 is provided to be continuous with the reduction portion 27 and to expand the groove width on both sides in the vertical direction D2. The groove width dimension of the expanded accommodating portion 28 in the vertical direction D2 is formed to be substantially the same as the dimension obtained by adding the interval (the interval of the state of not being elastically
10 deformed) between the two adjacent horizontal rails 21 accommodated in the expanded accommodating portion 28 and the width of the two horizontal rails 21.

When the horizontal rails 21 are moved toward and accommodated in the expanded accommodating portion 28, elastic deformation of the horizontal rails 21 of the protective member 20 is released, and the horizontal rails 21 of the protective member 20
15 are accommodated and locked in the expanded accommodating portion 28.

[0031]

Further, in a groove portion 26B (the groove portion 26B at both ends) other than the groove portion 26A located at the center in the vertical direction D2, the inclined guide surface 29 is provided in the reduction portion 27 only on the groove portion 26A
20 side, and the expanded accommodating portion 28 is provided only on the groove portion 26A side. That is, the groove portion 26B has the same shape as the half portion when the groove portion 26A is divided at the center in the vertical direction D2.

[0032]

As shown in FIGS. 3 to 5, the locking member 30 is detachably provided in each
25 of the fixing portions 25, and restricts movement of the horizontal rail 21 of the

protective member 20 inserted into the groove portion 26 of the fixing portion 25 in the mounted state.

The locking member 30 has a locking portion 31 protruding to the upstream side at a position corresponding to the space between the groove portions 26 of the fixing portion 25. As shown in FIG. 5, a pair of locking portions 31 are disposed to be spaced apart from each other in the horizontal direction D1 so as to sandwich both sides of the fixing portion 25, and a locking claw 32 is provided on the leading end side. Here, a locking hole 33 is provided on a further upstream side (upper part) than the end portion on the upstream side of the groove portion 26 between the adjacent groove portions 26 of the fixing portion 25. When the pair of locking portions 31 are elastically deformed to separate from and approach each other in the horizontal direction D1, the locking claw 32 can be locked in the locking hole 33.

[0033]

The locking member 30 also has a support portion 34 for supporting the horizontal rail 21 of the protective member 20 accommodated in the expanded accommodating portion 28, at a position corresponding to the groove portion 26 of the fixing portion 25. The support portion 34 is provided in a shape corresponding to the groove portion 26. In addition, the support portion 34 is integrally provided with the pair of locking portions 31, while supporting the pair of locking portions 31 from the downstream side.

[0034]

Further, in a state in which the locking portion 31 is locked to the fixing portion 25, the support portion 34 has a shape which comes into contact with the horizontal rail 21 of the protective member 20 accommodated in the groove portion 26 and can restrict the movement. Specifically, in the present embodiment, a substantially semicircular

recessed portion 34a that is recessed toward the downstream side is provided in the support portion 34 continuously to the downstream end portion of each locking portion 31. Further, by sandwiching the horizontal rails 21 accommodated in the groove portion 26 and disposed in the expanded accommodating portion 28 between the inner surface of the recessed portion 34a and the fixing portion 25, movement of the horizontal rails 21 is restricted.

[0035]

Here, the indoor unit 10 of such an air conditioner 100 can be assembled by an assembling method (see FIG. 6) having a process of assembling the aforementioned protective member 20 to the blowout port 15.

[0036]

First, a process S1 of providing the groove portion 26 is performed. That is, a fixing portion 25 (or a fixing portion 25 other than a pillar) as a pillar is provided in the blowout port 15, and a groove portion 26 is provided in each fixing portion 25 so as to be recessed from the downstream side to the upstream side. The groove portion 26 may be provided by notching an existing pillar or a pillar provided with the groove portion 26 in advance may be mounted in place of the existing pillar.

[0037]

In this state, a process S2 of inserting the rail is executed. That is, the protective member 20 is disposed on the downstream side of the fixing portion 25 to cover the blowout port 15. At this time, as shown in FIG. 2, the vertical rail 22 is disposed at the position of the louver 17 so that the horizontal rail 21 between the adjacent vertical rails 22 is disposed at the position of the groove portion 26 of the fixing portion 25. Thereafter, as shown in FIG. 4, the protective member 20 is moved to the upstream side to insert the horizontal rails 21 of the protective member 20 into the

respective groove portions 26.

[0038]

In the process S2 of inserting the rail, by further pressing the protective member 20 to the upstream side, the horizontal rails 21 are moved to the upstream side within the reduction portion 27 of the groove portion 26. At this time, the horizontal rails 21 of the protective member 20 are guided by the inclined guide surfaces 29 and are elastically deformed, and the interval between the adjacent horizontal rails 21 is reduced. Further, when the horizontal rails 21 of the protective member 20 are further moved to the upstream side and the horizontal rails 21 reach the expanded accommodating portion 28, the elastic deformation of the horizontal rails 21 due to the reduction portions 27 is released, the interval between the horizontal rails 21 widens, and each horizontal rail 21 is accommodated in the expanded accommodating portion 28.

[0039]

Finally, a process S3 of locking the locking member is executed. That is, after inserting the horizontal rails 21 of the protective member 20 into the respective groove portions 26, as shown in FIG. 4, the locking member 30 is opposed so as to be locked to the fixing portion 25 from the downstream side of the protective member 20, and is moved upward. As a result, the movement of the horizontal rails 21 of the protective member 20 inserted in the groove portions 26 of the fixing portion 25 is restricted by the locking member 30.

[0040]

According to the indoor unit 10 of the air conditioner 100 and the method for assembling the air conditioner 100 according to the present embodiment as described above, in the fixing portion 25 provided in the blowout port 15 to extend in the vertical direction D2, the groove portion 26 recessed from the downstream side to the upstream

side is provided so that the horizontal rails 21 of the protective member 20 are inserted into the groove portions 26. Therefore, by disposing the protective member 20 covering the blowout port 15 to allow ventilation on the downstream side of the blowout port 15, and by inserting the horizontal rails 21 into the groove portion 26 of the fixing portion 25
5 from the downstream side of the blowout port 15, the protective member 20 can be easily and directly disposed at a predetermined position of the blowout port 15.

[0041]

Further, the locking member 30 is locked to the fixing portion 25 from the downstream side of the protective member 20 to restrict the movement of the horizontal
10 rails 21 inserted in the groove portions 26. Therefore, in the state in which the protective member 20 is disposed on the downstream side of the blowout port 15 and the horizontal rails 21 are inserted into the groove portions 26, by locking the locking member 30 to the fixing portion 25, the protective member 20 can be easily supported by the blowout port 15 and the protective member 20 can be easily and directly assembled to
15 the blowout port 15, and thus the assembling property can be improved.

[0042]

Here, even when the horizontal rail 21 does not reach the expanded accommodating portion 28 and is located within the reduction portion 27, by locking the locking members 30 to the fixing portions 25, while pushing the horizontal rails 21
20 toward the upstream side by the locking member 30, it is possible to easily accommodate the horizontal rails 21 in the expanded accommodating portions 28.

[0043]

Further, in the present embodiment, since the horizontal rail 21 having a rod shape is connected and fixed by the vertical rails 22 at a predetermined position, it is
25 possible to dispose a plurality of horizontal rails 21 at predetermined intervals or to

elastically deform a plurality of horizontal rails 21 with moderate strength. Therefore, since the horizontal rails 21 can be moderately elastically deformed and inserted into the groove portions 26 of the fixing portion 25, workability at the time of mounting can be improved.

5 [0044]

Since the vertical rail 22 is disposed at a position corresponding to the louver 17 of the blowout port 15, it is possible to suppress hindrance of the flow of air A from the blowing fan 14 and then blown out of the blowout port 15.

[0045]

10 In the indoor unit 10 of the present embodiment, the vertical rails 22 are disposed on the upstream side of the horizontal rail 21, and the vertical rails 22 are not disposed outside the horizontal rails 21. Therefore, it is possible to suppress the protruding portion of the protective member 20 to the outside (downstream side) to be small and to improve the aesthetic appearance of the indoor unit 10.

15 [0046]

In the indoor unit 10 of the present embodiment, when the fixing portion 25 is a pillar that reinforces the blowout port 15, the protective member 20 of the blowout port 15 can be mounted, using a member that reinforces the blowout port 15. Therefore, it is not necessary to newly provide the fixing portion 25 additionally provided with the
20 groove portion 26 in the blowout port 15. Therefore, it is possible to prevent the structure of the blowout port 15 from becoming complicated, and it is difficult to hinder the flow of the air blown out of the blowout port 15.

[0047]

In the indoor unit 10 of the present embodiment, the groove portion 26 has a
25 reduction portion 27 and the expanded accommodating portion 28 which is wider than

the reduction portion 27 on the upstream side of the reduction portion 27. Therefore, when the horizontal rail 21 of the protective member 20 is inserted into the groove portion 26 from the front side (downstream side, lower side), the horizontal rail 21 is supported by the fixing portion 25 from the downstream side (lower side) by the expanded accommodating portion 28, and the protective member 20 does not fall by gravity or the like. That is, the protective member 20 can be stably installed in the blowout port 15.

[0048]

Although the embodiments of the present invention have been described in detail above, it is possible to make some design changes within a range that does not depart from the technical idea of the present invention.

For example, the protective member 20 may include a plurality of divided members.

Further, each of the horizontal rails 21 and the vertical rails 22 is in the shape of a round rod which is elastically deformable. However, as long as the protective member 20 can be inserted into the groove portion 26, the protective member 20 is not limited to the above-mentioned shape. For example, each of the horizontal rails 21 and the vertical rails 22 may have a square bar shape, or only a plurality of horizontal rails 21 may be provided (in this case, a fixing member for fixing the plurality of horizontal rails 21 instead of the vertical rails 22 is required).

While preferred embodiments of the invention have been described and shown above, it should be understood that these are exemplary of the invention and are not to be considered as limiting. Additions, omissions, substitutions, and other modifications can be made without departing from the spirit or scope of the present invention.

Accordingly, the invention is not to be considered as being limited by the foregoing

description, and is only limited by the scope of the appended claims.

EXPLANATION OF REFERENCES

[0049]

- | | |
|----|-----------------------------------|
| 5 | D1 Horizontal direction |
| | D2 Vertical direction |
| | 10 Indoor unit |
| | 11 Housing |
| | 12 Flap |
| 10 | 13 Heat exchanger |
| | 14 Blowing fan |
| | 15 Blowout port |
| | 15a Opening end |
| | 17 Louver |
| 15 | 17a Vane |
| | 20 Protective member |
| | 21 Horizontal rail |
| | 22 Vertical rail |
| | 25 Fixing portion |
| 20 | 26 (26A, 26B) Groove portion |
| | 27 Reduction portion |
| | 28 Expanded accommodating portion |
| | 29 Inclined guide surface |
| | 30 Locking member |
| 25 | 31 Locking portion |

5

32 Locking claw

33 Locking hole

34 Support portion

34a Recessed portion

100 Air conditioner

S1 Process of providing groove portion

S2 Process of inserting rail

S3 Process of locking locking member

What is claimed is:

1. An indoor unit of an air conditioner comprising:

a housing;

5 a blowing fan and a heat exchanger accommodated in the housing;

a blowout port extending in a horizontal direction and provided in a lower
portion of the housing to blow air from the blowing fan into a room;

a fixing portion provided to cross the blowout port;

10 a groove portion provided in the fixing portion to be recessed from an end
portion on a downstream side of the air flow toward an upstream side;

a protective member which is disposed on the downstream side of the fixing
portion, covers the blowout port to allow ventilation, and has a rail capable of being
inserted into the groove portion; and

15 a locking member which is locked to the fixing portion from the downstream
side of the protective member to restrict movement of the rail inserted into the groove
portion,

wherein the protective member has a plurality of rod-like horizontal rails having
elasticity, as the rail, the plurality of rod-like horizontal rails extending in the horizontal
direction and disposed to be spaced apart from each other in a vertical direction

20 intersecting with the horizontal direction,

wherein the protective member further has a rod-like vertical rail which is
disposed to extend in the vertical direction at a position of a louver provided at the
blowout port so as to extend in the vertical direction, and connects and fixes the plurality
of horizontal rails in the vertical direction at predetermined intervals,

25 wherein the groove portion includes a reduction portion having a pair of inclined

guide surfaces in which a width gradually decreases from the downstream side toward the upstream side; and

an expanded accommodating portion provided to be wider than the reduction portion on the upstream side of the reduction portion and capable of locking and

5 accommodating the two adjacent horizontal rails, and

wherein the groove width dimension of the expanded accommodating portion in the vertical direction is formed to be the same as the dimension obtained by adding the interval between the two adjacent horizontal rails accommodated in the expanded accommodating portion and the width of the two horizontal rails.

10

2. The indoor unit of the air conditioner according to claim 1, wherein the vertical rail is disposed on the upstream side of the horizontal rail.

3. The indoor unit of the air conditioner according to claim 1 or 2, wherein the fixing portion is a pillar which extends in a vertical direction intersecting with the horizontal direction at the blowout port to reinforce the blowout port.

15

4. A method for assembling an indoor unit of an air conditioner, the method comprising:

20

providing a fixing portion in a vertical direction intersecting with a horizontal direction, at a blowout port extending in the horizontal direction and provided in a lower portion of a housing to blow air from a blowing fan into a room, and providing a groove portion in the fixing portion to be recessed from an end portion on a downstream side of a flow of air toward an upstream side;

25

disposing a protective member configured to cover the blowout port to allow the

ventilation on the downstream side of the fixing portion and inserting a rail of the protective member from the downstream side into the groove portion; and

locking the locking member to the fixing portion from the downstream side of the protective member to restrict movement of the rail inserted into the groove portion,

5 wherein the protective member includes

a plurality of rod-like horizontal rails having elasticity, extending in the horizontal direction and disposed to be spaced apart from each other in a vertical direction intersecting with the horizontal direction, wherein the protective member further has a rod-like vertical rail which is disposed to extend in the vertical direction,

10 and connects and fixes the plurality of horizontal rails at predetermined intervals,

wherein the groove portion includes

a reduction portion having a pair of inclined guide surfaces in which a width gradually decreases from the downstream side toward the upstream side; and

15 an expanded accommodating portion provided to be wider than the reduction portion on the upstream side of the reduction portion and capable of locking and accommodating the two adjacent horizontal rails, and

20 wherein the groove width dimension of the expanded accommodating portion in the vertical direction is formed to be the same as the dimension obtained by adding the interval between the two adjacent horizontal rails accommodated in the expanded accommodating portion and the width of the two horizontal rails.

FIG. 1

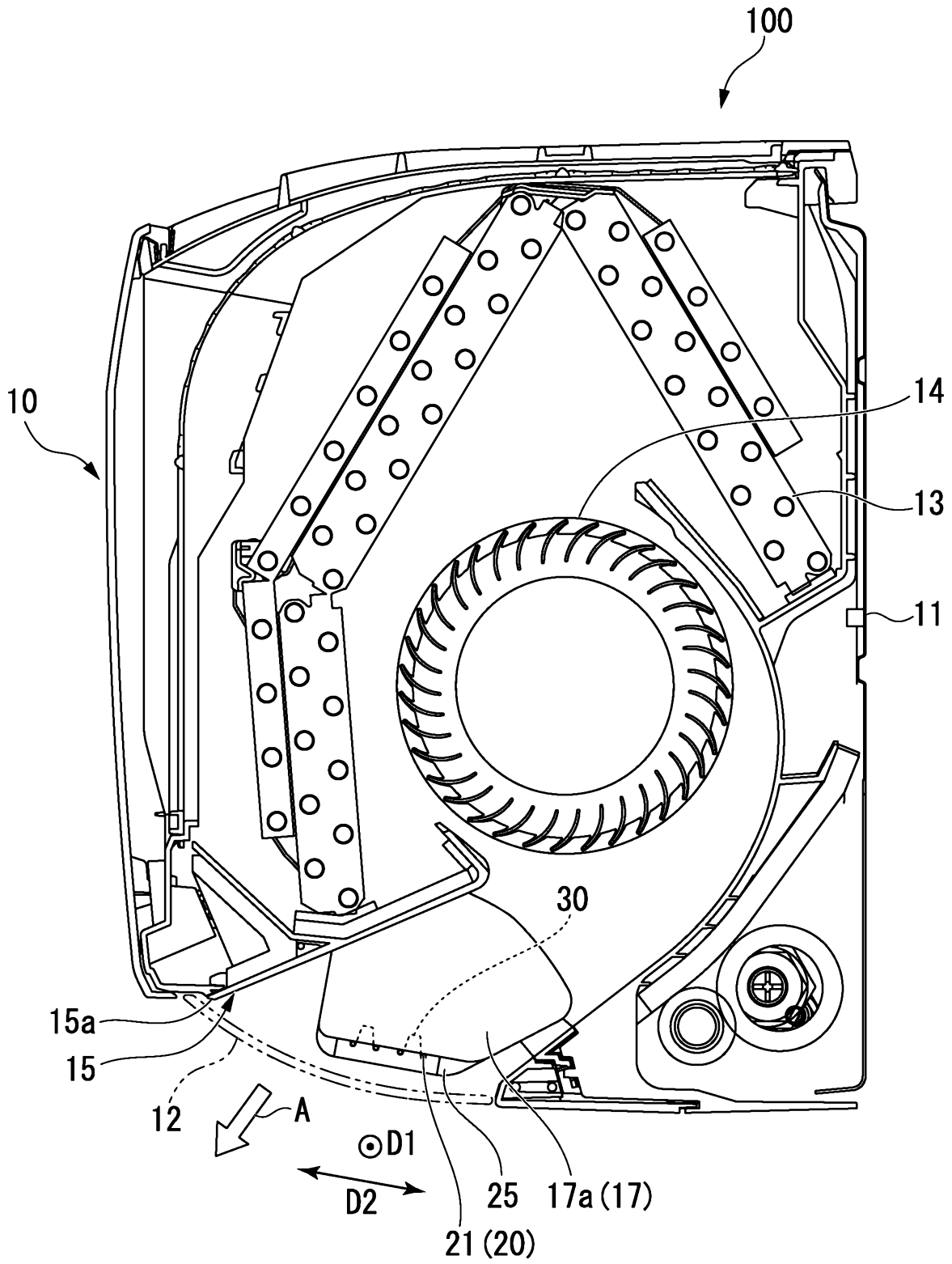

FIG. 2A

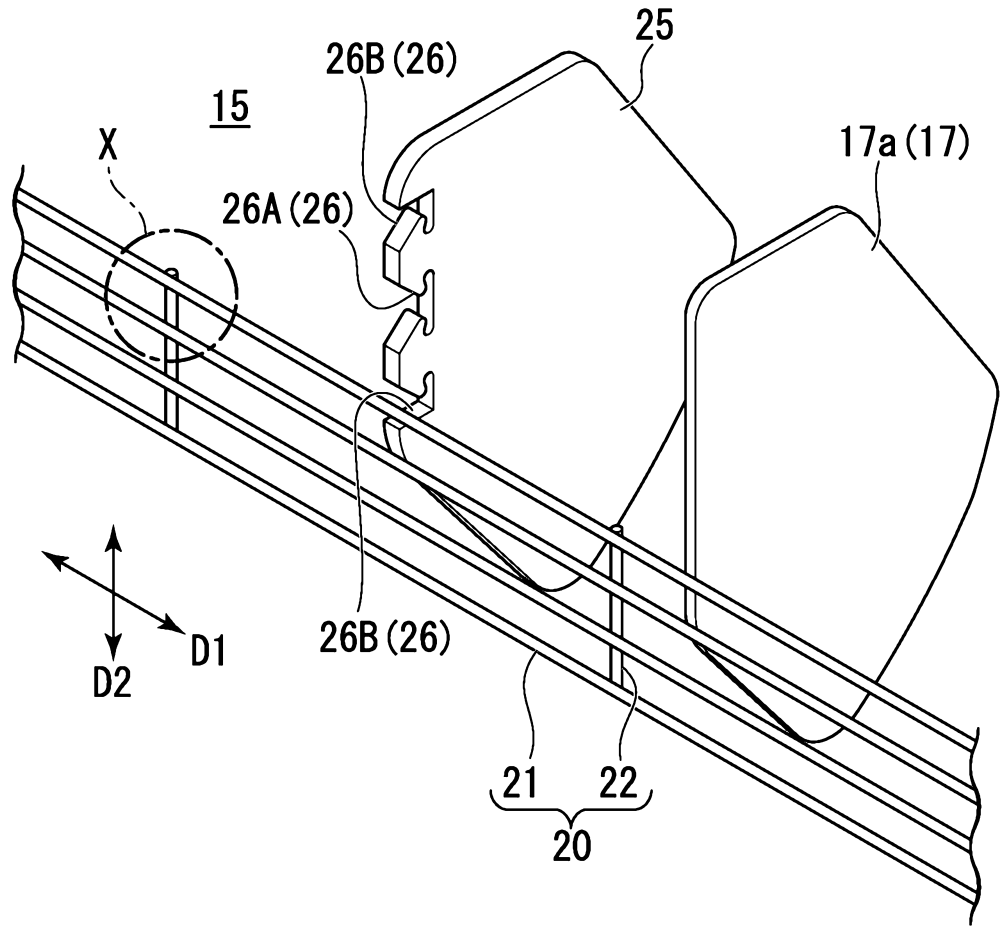

FIG. 2B

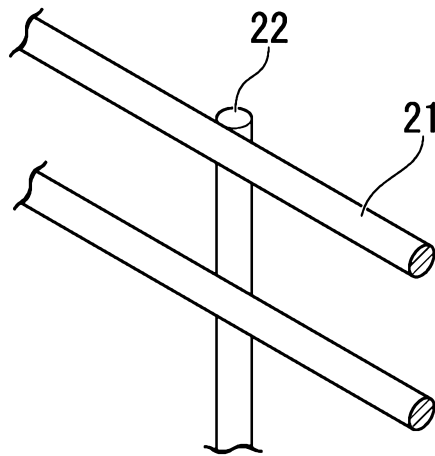

FIG. 3

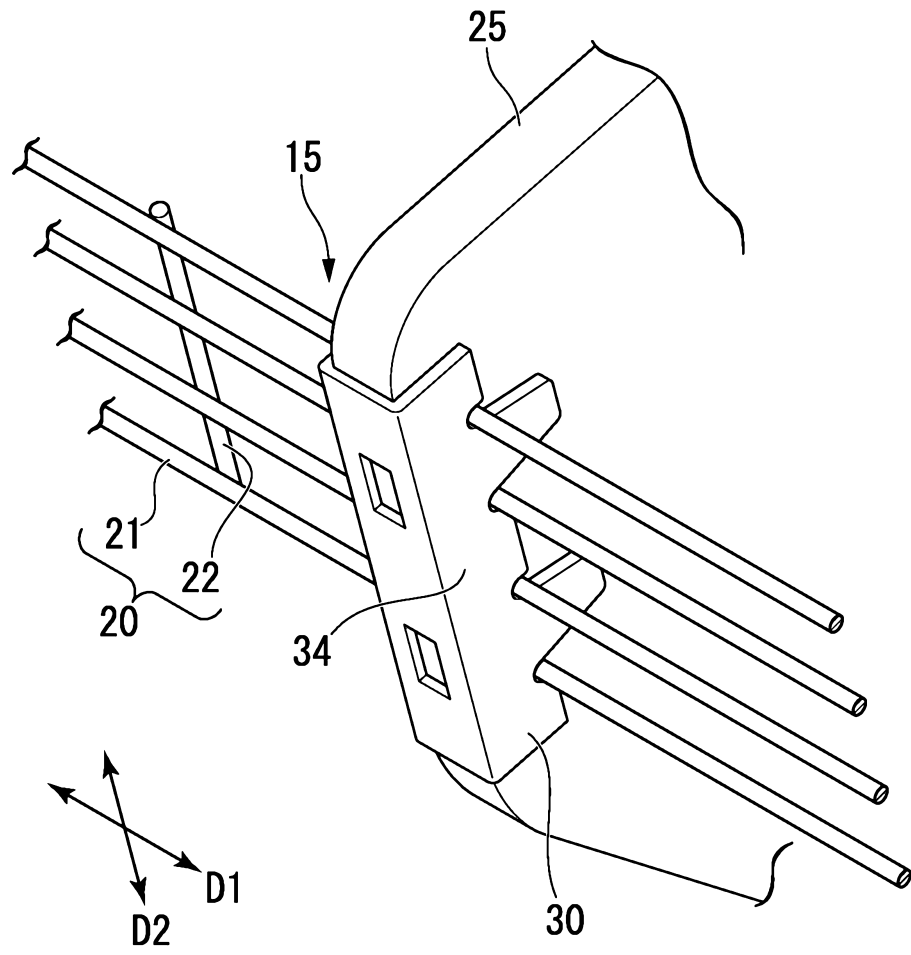

FIG. 4

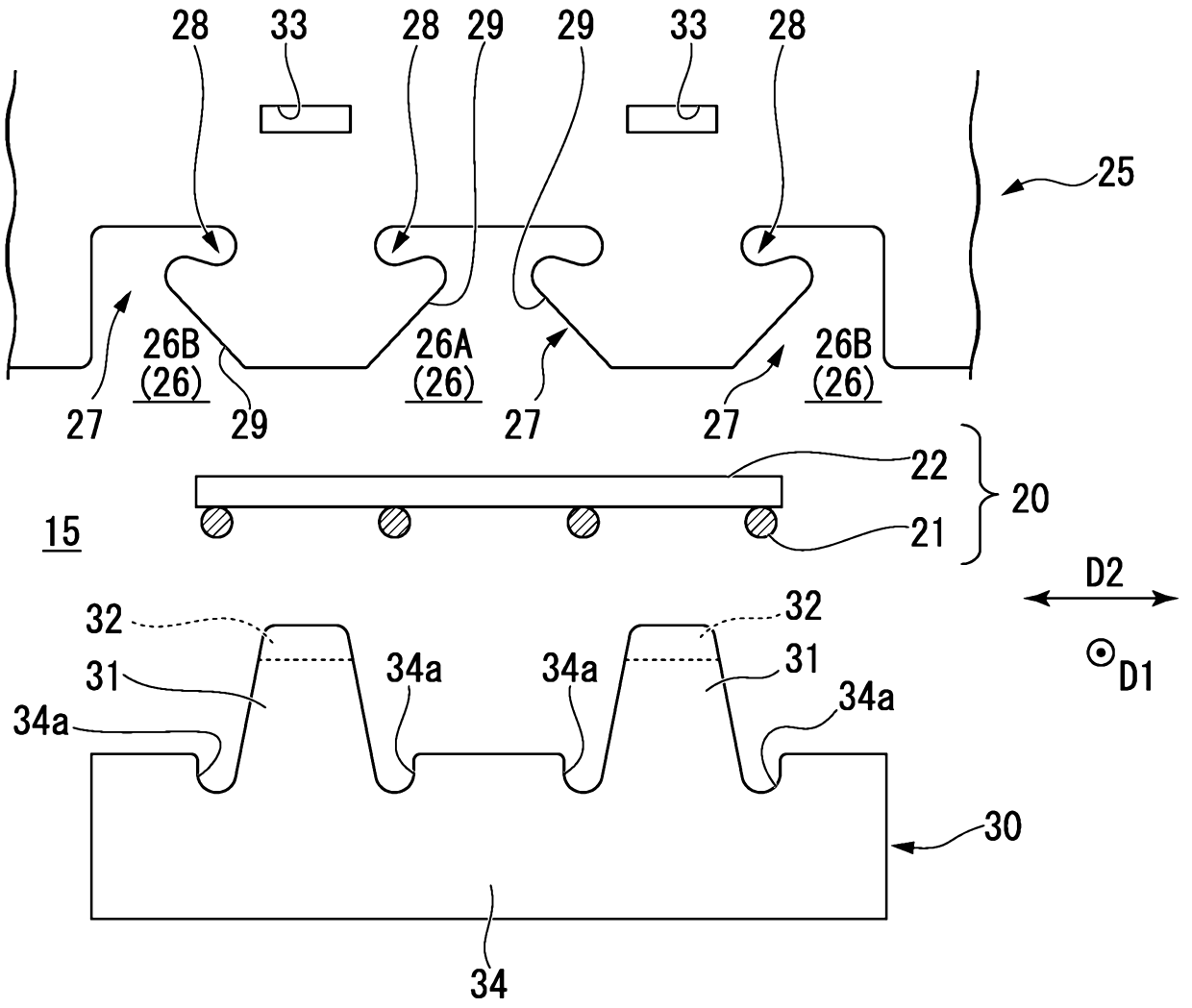

FIG. 5

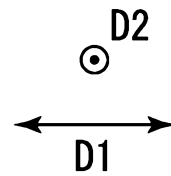
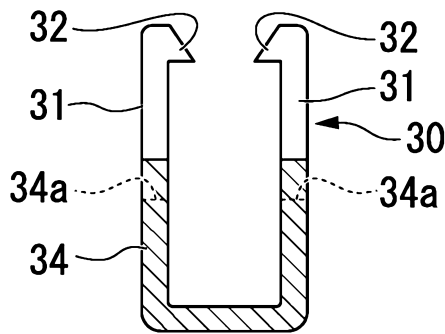
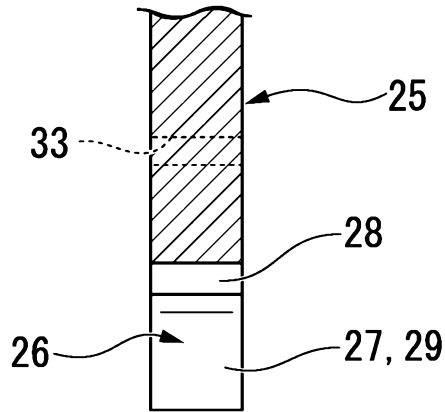

FIG. 6

