



(19) **United States**
(12) **Patent Application Publication**
McClain et al.

(10) **Pub. No.: US 2013/0172853 A1**
(43) **Pub. Date: Jul. 4, 2013**

(54) **DRUG DELIVERY MEDICAL DEVICE**

Publication Classification

(75) Inventors: **James B. McClain**, Raleigh, NC (US);
Charles Douglas Taylor, Franklinton,
NC (US); **Brett G. Zani**, Arlington, MA
(US); **John Neet**, Lawrence, KS (US);
Timothy Charles Kiorpes, Doylestown,
PA (US)

(51) **Int. Cl.**
A61M 25/10 (2006.01)
(52) **U.S. Cl.**
CPC *A61M 25/10* (2013.01); *A61M 25/1011*
(2013.01)
USPC **604/509**; 604/103.02; 604/101.01

(73) Assignee: **MICELL TECHNOLOGIES, INC.**,
Durham, NC (US)

(57) **ABSTRACT**

Provided is a coated implantable medical device, comprising: a substrate; and a coating disposed on the substrate, wherein the coating comprises at least one polymer and at least one pharmaceutical agent in a therapeutically desirable morphology and/or at least one active biological agent and optionally, one or more pharmaceutical carrying agents; wherein substantially all of pharmaceutical agent and/or active biological agent remains within the coating and on the substrate until the implantable device is deployed at an intervention site inside the body of a subject and wherein upon deployment of the medical device in the body of the subject a portion of the pharmaceutical agent and/or active biological agent is delivered at the intervention site along with at least a portion of the polymer and/or a at least a portion of the pharmaceutical carrying agents.

(21) Appl. No.: **13/809,324**

(22) PCT Filed: **Jul. 15, 2011**

(86) PCT No.: **PCT/US11/44263**

§ 371 (c)(1),
(2), (4) Date: **Feb. 26, 2013**

Related U.S. Application Data

(60) Provisional application No. 61/365,282, filed on Jul. 16, 2010, provisional application No. 61/428,785, filed on Dec. 30, 2010.

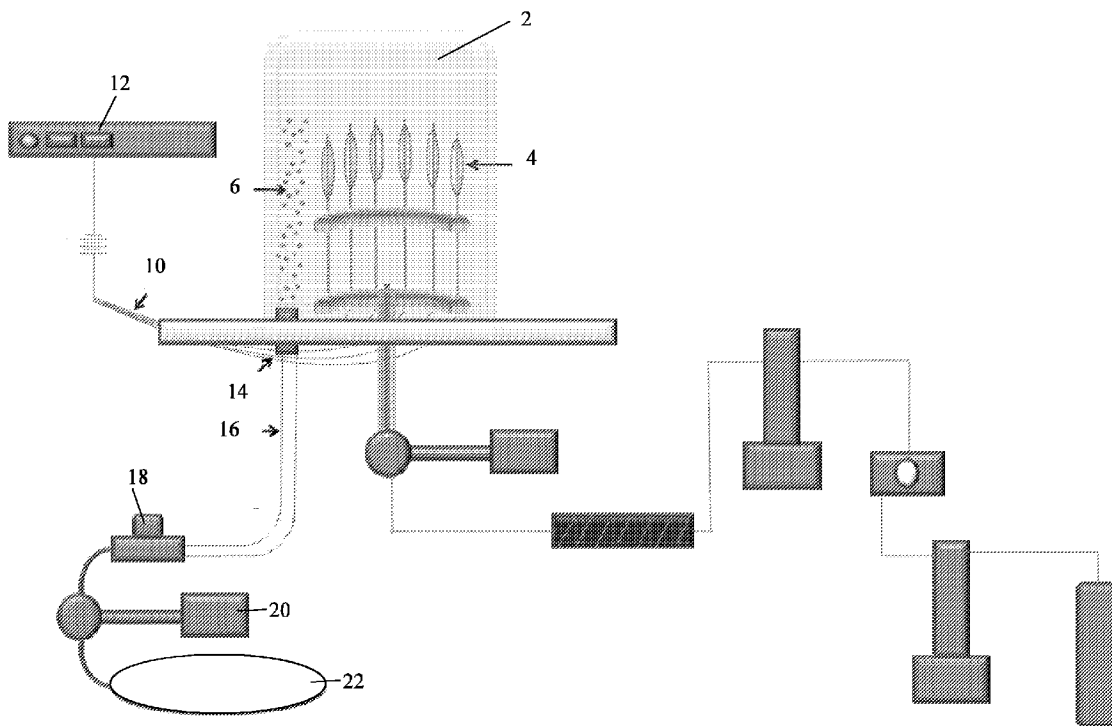

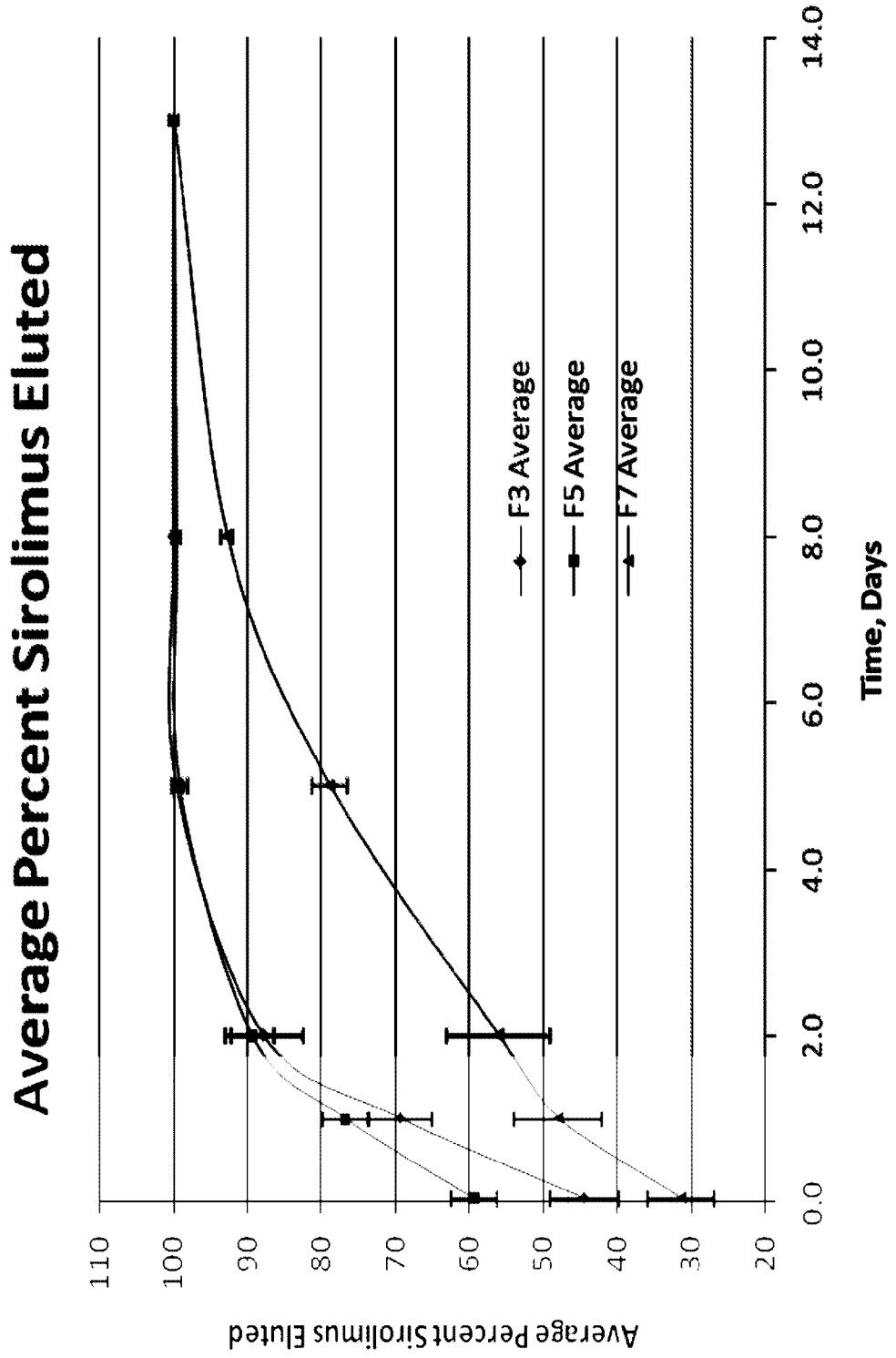
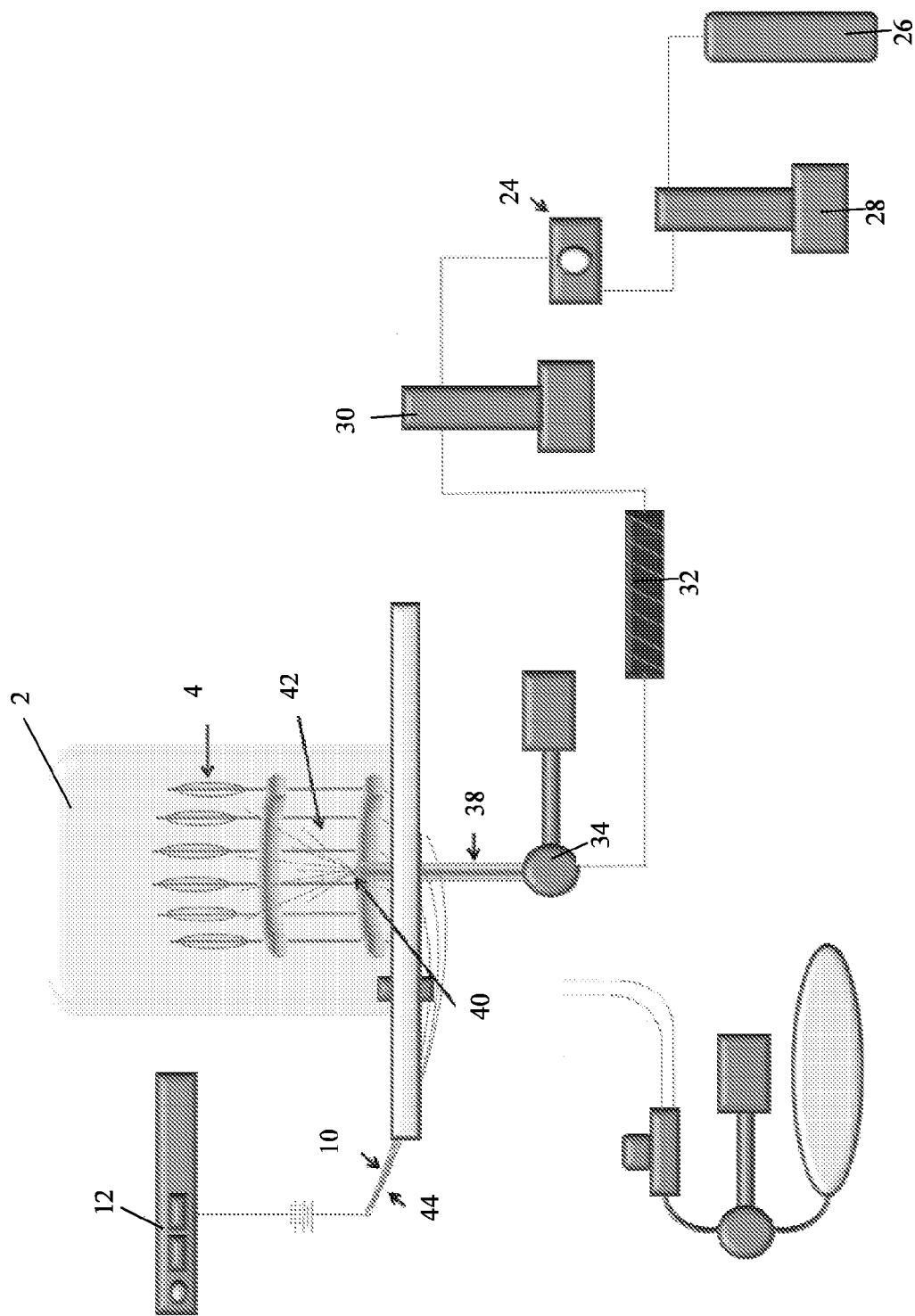

FIGURE 1

FIGURE 3



DRUG DELIVERY MEDICAL DEVICE

CROSS-REFERENCE

[0001] This application claims the benefit of U.S. Provisional Application No. 61/365,282 filed Jul. 16, 2010 and U.S. Provisional Application No. 61/428,785 filed Dec. 30, 2010, each of which is incorporated herein by reference in its entirety.

BACKGROUND OF THE INVENTION

[0002] There is a need for medical device technology that can rapidly, efficiently, reproducibly and safely transfer a Drug Delivery Formulation from the surface of a percutaneous medical device (a coating) onto/into a specific site in the body.

SUMMARY OF THE INVENTION

[0003] Provided herein is a medical device comprising: a balloon; and a coating on at least a portion of the balloon, wherein the coating comprises an active agent and a binding agent, and wherein the device releases at least 3% of the active agent to artery upon inflation of the balloon in vivo.

[0004] Provided herein is a method of forming coating on a medical device comprising depositing a polymer on the medical device using an RESS process, and depositing an active agent and a binding agent on the medical device wherein depositing the active agent and the binding agent uses an eSTAT process.

[0005] Provided herein is a method comprising providing a device comprising a balloon and a coating on at least a portion of the balloon, wherein the coating comprises an active agent and a binding agent; and inflating the balloon of the device in an artery in vivo, wherein upon inflating the balloon at least 3% of the active agent is transferred to tissue of the artery.

[0006] In some embodiments, the device releases at least 5% of the active agent to artery in vivo. In some embodiments, the device releases at least 10% of the active agent in vivo. In some embodiments, the device releases at least 5% of the active agent to artery upon inflation of the balloon in vivo. In some embodiments, the device releases at least 7% of the active agent to artery upon inflation of the balloon in vivo. In some embodiments, the device releases at least 10% of the active agent to artery upon inflation of the balloon in vivo. In some embodiments, the device releases at least 15% of the active agent to artery upon inflation of the balloon in vivo. In some embodiments, the device releases at least 20% of the active agent to artery upon inflation of the balloon in vivo. In some embodiments, the device releases at least 25% of the active agent to artery upon inflation of the balloon in vivo. In some embodiments, the device releases at least 30% of the active agent to artery upon inflation of the balloon in vivo. In some embodiments, the device releases at least 40% of the active agent to artery upon inflation of the balloon in vivo. In some embodiments, the device releases at least 50% of the active agent to artery upon inflation of the balloon in vivo. In some embodiments, the device releases between 2% and 50% of the active agent to artery upon inflation of the balloon in vivo. In some embodiments, the device releases between 3% and 50% of the active agent to artery upon inflation of the balloon in vivo. In some embodiments, the device releases between 5% and 50% of the active agent to artery upon inflation of the balloon in vivo. In some embodiments, the device releases between 3% and 30% of the active agent to

artery upon inflation of the balloon in vivo. In some embodiments, the device releases between 3% and 25% of the active agent to artery upon inflation of the balloon in vivo. In some embodiments, the device releases between 3% and 20% of the active agent to artery upon inflation of the balloon in vivo. In some embodiments, the device releases between 3% and 15% of the active agent to artery upon inflation of the balloon in vivo. In some embodiments, the device releases between 1% and 15% of the active agent to artery upon inflation of the balloon in vivo. In some embodiments, the device releases between 1% and 10% of the active agent to artery upon inflation of the balloon in vivo. In some embodiments, the device releases between 1% and 10% of the active agent to artery upon inflation of the balloon in vivo. In some embodiments, the device releases between 3% and 10% of the active agent to artery upon inflation of the balloon in vivo. In some embodiments, the device releases between 1% and 5% of the active agent to artery upon inflation of the balloon in vivo.

[0007] As used herein, depending on the embodiment, "upon inflation" means as soon as reasonably possible following removal of the device from the treatment site. This may include timings such as about 1 minute, about 5 minutes from removal of the device from the treatment site, within 1 to 15 minutes from the removal of the device from the treatment site, within 1 to 15 minutes from the removal of the device from the treatment site, within 1 to 20 minutes from the removal of the device from the treatment site, within 1 minute to 1 hour from the removal of the device from the treatment site, within 1 minute to 2 hour from the removal of the device from the treatment site, and/or within 1 minute to 3 hours from the removal of the device from the treatment site.

[0008] In some embodiments, the method comprises forming a dry mixture of the active agent and the binding agent prior to depositing the active agent and the binding agent on the device. Forming the dry mixture comprises lyophilizing the active agent and binding agent.

[0009] In some embodiments of the methods and/or devices provided herein, the active agent comprises a pharmaceutical agent.

[0010] The active agent in some embodiments of the devices, coatings and/or methods provided herein comprises a macrolide immunosuppressive drug. In some embodiments the macrolide immunosuppressive drug comprises one or more of rapamycin, 40-O-(2-Hydroxyethyl)rapamycin (everolimus), 40-O-Benzyl-rapamycin, 40-O-(4'-Hydroxymethyl)benzyl-rapamycin, 40-O-[4'-(1,2-Dihydroxyethyl)]benzyl-rapamycin, 40-O-Allyl-rapamycin, 40-O-[3'-(2,2-Dimethyl-1,3-dioxolan-4(S)-yl)-prop-2'-en-1'-yl]-rapamycin, (2':E,4'S)-40-O-(4',5'-Dihoxypent-2'-en-1'-yl)-rapamycin 40-O-(2-Hydroxy)ethoxycarbonylmethyl-rapamycin, 40-O-(3-Hydroxy)propyl-rapamycin 40—O-(6-Hydroxy)hexyl-rapamycin 40-O-[2-(2-Hydroxy)ethoxy]ethyl-rapamycin 40-O-[(3S)-2,2-Dimethyldioxolan-3-yl]methyl-rapamycin, 40-O-[(2S)-2,3-Dihydroxyprop-1-yl]-rapamycin, 40-O-(2-Acetoxy)ethyl-rapamycin 40-O-(2-Nicotinoyloxy)ethyl-rapamycin, 40-O-[2-(N-Morpholino)acetoxy]ethyl-rapamycin 40-O-(2-N-Imidazolylacetoxy)ethyl-rapamycin, 40-O-[2-(N-Methyl-N'-piperazinyl)acetoxy]ethyl-rapamycin, 39-O-Desmethyl-39,40-O,O-ethylene-rapamycin, (26R)-26-Dihydro-40-O-(2-hydroxy)ethyl-rapamycin, 28-O-Methyl-rapamycin, 40-O-(2-Aminoethyl)-rapamycin, 40—O-(2-Acetaminoethyl)-rapamycin 40—O-(2-Nicotinamidoethyl)-rapamycin, 40—O-(2-(N-Methyl-imidazo-2'-yl)carbethoxamido)ethyl)-rapamycin, 40—O-(2-Ethoxycarbonylaminoethyl)-rapamycin, 40-O-(2-Tolylsulfonamidoethyl)-rapamycin, 40-O-[2-

(4',5'-Dicarboethoxy-1',2',3'-triazol-1'-yl)-ethyl]-rapamycin, 42-Epi-(tetrazolyl)rapamycin (tacrolimus), and 42-[3-hydroxy-2-(hydroxymethyl)-2-methylpropanoate]rapamycin (temsirolimus). The active agent may be selected from a macrolide immunosuppressive drug, a prodrug, a hydrate, an ester, a salt, a polymorph, a derivative and an analog thereof. The active agent may be selected from sirolimus, a prodrug, a hydrate, an ester, a salt, a polymorph, a derivative and an analog thereof.

[0011] In some embodiments of the methods, coatings, and/or devices provided herein, the size of the active agent in the coating is controlled. In some embodiments, the active agent is sirolimus and wherein the sirolimus has an average size (mean diameter) of at least one of: 1.5 μm , 2.5 μm , 645 nm, 100-200 nm, another controlled size, or a combination thereof. In some embodiments, the active agent is sirolimus and wherein the sirolimus has a median size of at least one of: 1.5 μm , 2.5 μm , 645 nm, 100-200 nm, another controlled size, or a combination thereof. In some embodiments, the active agent is sirolimus and wherein the sirolimus has an average size (mean diameter) of at least one of: about 1.5 μm , about 2.5 μm , about 645 nm, about 100-200 nm, another controlled size, or a combination thereof. In some embodiments, the active agent is sirolimus and wherein sirolimus at least 75% of the sirolimus as is 1.5 μm , 2.5 μm , 645 nm, 100-200 nm, or another controlled size. In some embodiments, the active agent is sirolimus and wherein sirolimus at least 50% of the sirolimus as is 1.5 μm , 2.5 μm , 645 nm, 100-200 nm, or another controlled size. In some embodiments, the active agent is sirolimus and wherein sirolimus at least 90% of the sirolimus as is 1.5 μm , 2.5 μm , 645 nm, 100-200 nm, or another controlled size.

[0012] In some embodiments of the methods and/or devices provided herein, the macrolide immunosuppressive drug is at least 50% crystalline. In some embodiments, the macrolide immunosuppressive drug is at least 75% crystalline. In some embodiments, the macrolide immunosuppressive drug is at least 90% crystalline. In some embodiments of the methods and/or devices provided herein the macrolide immunosuppressive drug is at least 95% crystalline. In some embodiments of the methods and/or devices provided herein the macrolide immunosuppressive drug is at least 97% crystalline. In some embodiments of the methods and/or devices provided herein macrolide immunosuppressive drug is at least 98% crystalline. In some embodiments of the methods and/or devices provided herein the macrolide immunosuppressive drug is at least 99% crystalline.

[0013] In some embodiments of the methods and/or devices provided herein the pharmaceutical agent is at least 50% crystalline. In some embodiments of the methods and/or devices provided herein the pharmaceutical agent is at least 75% crystalline. In some embodiments of the methods and/or devices provided herein the pharmaceutical agent is at least 90% crystalline. In some embodiments of the methods and/or devices provided herein the pharmaceutical agent is at least 95% crystalline. In some embodiments of the methods and/or devices provided herein the pharmaceutical agent is at least 97% crystalline. In some embodiments of the methods and/or devices provided herein pharmaceutical agent is at least 98%

crystalline. In some embodiments of the methods and/or devices provided herein the pharmaceutical agent is at least 99% crystalline.

[0014] In some embodiments of the devices, coatings and/or methods provided herein the polymer comprises PLGA. In some embodiments of the methods, coatings, or devices provided herein, the PLGA comprises about 50:50 Lactic acid: Glycolic acid. The PLGA may have at least one of: a MW of about 30 KDa and a Mn of about 15 KDa, a Mn of about 10 KDa to about 25 KDa, and a MW of about 15 KDa to about 40 KDa.

[0015] In some embodiments of the devices, coatings and/or methods provided herein the coating comprises a positive surface charge on a surface of the coating configured to contact the treatment site.

[0016] In some embodiments of the devices, coatings and/or methods provided herein the coating comprises a binding agent. In some embodiments, the binding agents comprises at least one of: Polyarginine, Polyarginine 9-L-pArg, DEAE-Dextran (Diethylaminoethyl cellulose-Dextran), DMAB (Didecyltrimethylammonium bromide), PEI (Polyethylenimine), TAB (Tetradecylammonium bromide), and DMTAB (Dimethylditetradecylammonium bromide). In some embodiments, the binding agent comprises a surfactant. In some embodiments the surfactant is cationic. In some embodiments the surfactant comprises at least one of a primary amine having $\text{pH} < 10$, and a secondary amine having $\text{pH} < 4$. In some embodiments surfactant comprises octenidine dihydrochloride. In some embodiments the surfactant comprises a permanently charged quaternary ammonium cation. In some embodiments the permanently charged quaternary ammonium cation comprises at least one of: an Alkyltrimethylammonium salt such as cetyl trimethylammonium bromide (CTAB), hexadecyl trimethyl ammonium bromide, cetyl trimethylammonium chloride (CTAC); Cetylpyridinium chloride (CPC); Polyethoxylated tallow amine (POEA); Benzalkonium chloride (BAC); Benzethonium chloride (BZT); 5-Bromo-5-nitro-1,3-dioxane; Dimethyldioctadecylammonium chloride; and Dioctadecyldimethylammonium bromide (DODAB). In some embodiments the surfactant comprises at least one of: didodecyldimethylammonium bromide (DMAB), linear isoform Polyethylenimine (linear PEI), Branched Low MW Polyethylenimine (PEI) (of about < 25 KDa), Branched Low MW Polyethylenimine (PEI) (of about < 15 KDa), Branched Low MW Polyethylenimine (PEI) (of about < 10 KDa), Branched High MW Polyethylenimine (of about ≥ 25 KDa), Poly-L-Arginine (average or nominal MW of about 70,000 Da), Poly-L-Arginine (average or nominal MW $>$ about 50,000 Da), Poly-L-Arginine (average or nominal MW of about 5,000 to about 15,000 Da), Poly-L-Lysine (average or nominal MW of about 28,200 Da), Poly-L-Lysine (average or nominal MW of about 67,000 Da), Poly Histidine, Ethylhexadecyldimethylammonium Bromide, Dodecyltrimethyl Ammonium Bromide, Tetradecylammonium bromide, Dimethylditetradecyl Ammonium bromide, Tetrabutylammonium iodide, DEAE-Dextran hydrochloride, and Hexadimethrine Bromide. In some embodiments, the molecular weight of the binding agent is controlled. In some embodiments, the average size of the binding agent is controlled.

[0017] In some embodiments of the devices, coatings and/or methods provided herein the binding agent and the active agent are mixed and deposited together on the device. In some

embodiments, the active agent and binding agent are lyophilized prior to deposition on the device. In some embodiments dry particles of the active agent and binding agent are generated in another manner familiar to one of skill in the art and then coated on the balloon or other medical device as described herein, such as by an eSTAT coating process.

[0018] In some embodiments of the devices, coatings and/or methods provided herein the surfactant is deposited on a balloon after the active agent is deposited thereon.

[0019] The positive surface charge may be about 20 mV to about 40 mV. The positive surface charge may be at least one of: at least about 1 mV, over about 1 mV, at least about 5 mV, at least about 10 mV, about 10 mV to about 50 mV, about 20 mV to about 50 mV, about 10 mV to about 40 mV, about 30 mV to about 40 mV, about 20 mV to about 30 mV, and about 25 mV to about 35 mV.

[0020] In some embodiments of the methods, coatings, or devices provided herein, the ratio of the active agent to the binding agent is 1:1, 1:2, 1:3, 1:4, 1:5, 1:10, 1:20, 2:1, 3:1, 4:1, 5:1, 10:1, 15:1, 20:1, 3:2, 2:3, 5:2, 5:3, 2:5, 3:5, or another controlled ratio.

[0021] In some embodiments of the methods, coatings, or devices provided herein, the coating may comprise nanoparticles, and the nanoparticles may comprise an active agent and a polymer.

[0022] In some embodiments of the methods, coatings, or devices provided herein, the coating comprised a 10:1 ratio of the active agent to the binding agent, wherein the active agent comprises sirolimus wherein the binding agent comprises Polyarginine. In some embodiments, the sirolimus has an average size of 1.5 μm or 2.5 μm . In some embodiments, the Polyarginine average molecular weight is 70 kDa. In some embodiments, the Polyarginine average molecular weight is 5-15 kDa. In some embodiments, the active agent and the binding agent are deposited on the balloon together using an eSTAT coating process. In some embodiments, the active agent and the binding agent are lyophilized prior to deposition on the balloon. In some embodiments, at least about 2 ng/mg of active agent are found in arterial tissue 72 hours after inflation of the balloon in the artery. In some embodiments, at least about 3 ng/mg of active agent are found in arterial tissue 72 hours after inflation of the balloon in the artery. In some embodiments, at least about 5 ng/mg of active agent are found in arterial tissue 72 hours after inflation of the balloon in the artery. In some embodiments, at least about 10 ng/mg of active agent are found in arterial tissue 72 hours after inflation of the balloon in the artery. In some embodiments, at least about 20 ng/mg of active agent are found in arterial tissue 72 hours after inflation of the balloon in the artery. In some embodiments, at least about 30 ng/mg of active agent are found in arterial tissue 72 hours after inflation of the balloon in the artery. In some embodiments, at least about 40 ng/mg of active agent are found in arterial tissue 72 hours after inflation of the balloon in the artery.

[0023] In some embodiments of the methods, coatings, or devices provided herein, in vivo measurement comprises inflating the balloon inside the artery of a porcine for about 1 minute and wherein the amount of active agent transferred to the artery is measured by UV-Vis evaluation of the coating remaining on the balloon as determined about five minutes after inflation of the balloon in the artery. In some embodiments of the methods, coatings, or devices provided herein, in vivo measurement comprises inflating the balloon inside the artery of a porcine for about 1 minute and wherein the amount

of active agent transferred to the artery is measured by extracting the artery about five minutes after inflation of the balloon in the artery and determining the amount of drug in the extracted artery using standard methods described herein and/or known to one of skill in the art. In some embodiments of the methods, coatings, or devices provided herein, in vivo measurement comprises inflating the balloon inside the artery of a rabbit for about 1 minute and wherein the amount of active agent transferred to the artery is measured by UV-Vis evaluation of the coating remaining on the balloon as determined about five minutes after inflation of the balloon in the artery. In some embodiments of the methods, coatings, or devices provided herein, in vivo measurement comprises inflating the balloon inside the artery of a rabbit for about 1 minute and wherein the amount of active agent transferred to the artery is measured by extracting the artery about five minutes after inflation of the balloon in the artery and determining the amount of drug in the extracted artery using standard methods described herein and/or known to one of skill in the art.

[0024] Provided herein is a method of forming a coating on a medical device comprising depositing a polymer on the medical device using an RESS process, mixing a binding agent and active agent to create an active agent-binding agent mixture, lyophilizing the active agent-binding agent mixture and depositing the active agent-binding agent mixture on the medical device using an eSTAT process. In some embodiments, the binding agent comprises a surfactant.

[0025] The coating may release the active agent into a treatment site over at least one of: about 3 days, about 5 days, about 1 week, about 1.5 weeks, about 2 weeks, about 14 days, about 3 weeks, about 21 days, about 4 weeks, about 28 days, about 1 month, about 1.5 months, about 2 months, at least about 3 days, at least about 5 days, at least about 1 week, at least about 1.5 weeks, at least about 2 weeks, at least about 14 days, at least about 3 weeks, at least about 21 days, at least about 4 weeks, at least about 28 days, at least about 1 month, at least about 1.5 months, at least about 2 months, about 7 to about 14 days, about 14 to about 21 days, about 14 to about 28 days, about 21 to about 28 days, and about 7 to about 28 days.

[0026] Provided herein is a coated medical device comprising: a medical device for delivering encapsulated active agent to a treatment site; and a coating on the medical device comprising the encapsulated active agent wherein the encapsulated active agent comprise active agent encapsulated in a polymer, and wherein the encapsulated active agent has a positive surface charge.

[0027] Provided herein is a coated medical device comprising: a medical device for delivering encapsulated active agent to a treatment site; and a coating on the medical device comprising the encapsulated active agent wherein the encapsulated active agent comprise a polymer that encapsulates at least a portion of an active agent, and wherein the encapsulated active agent has a positive surface charge.

[0028] In some embodiments, the active agent is not completely encapsulated. An active agent (or a portion thereof) need not be completely surrounded in order to be encapsulated by the polymer. In some embodiments, at least 10% of the surface area of the active agent is encapsulated in the polymer. In some embodiments, at least 20% of the surface area of the active agent is encapsulated in the polymer. In some embodiments, at least 25% of the surface area of the active agent is encapsulated in the polymer. In some embodiments, at least 30% of the surface area of the active agent is

encapsulated in the polymer. In some embodiments, at least 40% of the surface area of the active agent is encapsulated in the polymer. In some embodiments, at least 50% of the surface area of the active agent is encapsulated in the polymer. In some embodiments, at least 60% of the surface area of the active agent is encapsulated in the polymer. In some embodiments, at least 70% of the surface area of the active agent is encapsulated in the polymer. In some embodiments, at least 75% of the surface area of the active agent is encapsulated in the polymer. In some embodiments, at least 80% of the surface area of the active agent is encapsulated in the polymer. In some embodiments, at least 90% of the surface area of the active agent is encapsulated in the polymer. In some embodiments, at least 95% of the surface area of the active agent is encapsulated in the polymer. In some embodiments, at least one of: at least 5% of the surface area of the active agent is at least partially surrounded by the polymer, at least 10% of the surface area of the active agent is at least partially surrounded by the polymer, at least 15% of the surface area of the active agent is at least partially surrounded by the polymer, at least 20% of the surface area of the active agent is at least partially surrounded by the polymer, at least 25% of the surface area of the active agent is at least partially surrounded by the polymer, at least 30% of the surface area of the active agent is at least partially surrounded by the polymer, at least 40% of the surface area of the active agent is at least partially surrounded by the polymer, at least 50% of the surface area of the active agent is at least partially surrounded by the polymer, at least 60% of the surface area of the active agent is at least partially surrounded by the polymer, at least 70% of the surface area of the active agent is at least partially surrounded by the polymer, at least 75% of the surface area of the active agent is at least partially surrounded by the polymer, at least 80% of the surface area of the active agent is at least partially surrounded by the polymer, at least 90% of the surface area of the active agent is at least partially surrounded by the polymer, and at least 95% of the surface area of the active agent is at least partially surrounded by the polymer.

[0029] Provided herein is a coating for a medical device comprising encapsulated active agent comprising active agent encapsulated in a polymer, wherein the encapsulated active agent has a positive surface charge, and wherein the coating delivers active agent to a treatment site over at least about 1 day.

[0030] Provided herein is a method of forming a coating on a medical device comprising providing encapsulated active agent comprising a polymer and active agent, wherein the encapsulated active agent have a positive surface charge, depositing the encapsulated active agent on the medical device. In some embodiments, the coating delivers the active agent to the treatment site over at least about 1 day.

[0031] Provided herein is a method of forming a coating on a medical device comprising providing encapsulated active agent comprising a polymer at least partially encapsulating at least a portion of an active agent wherein the encapsulated active agent has a positive surface charge, and depositing the encapsulated active agent on the medical device. In some embodiments, the coating delivers the active agent to the treatment site over at least about 1 day.

[0032] In some embodiments, the active agent is not completely encapsulated. An active agent (or a portion thereof) need not be completely surrounded in order to be encapsulated by the polymer. In some embodiments, at least 10% of the surface area of the active agent is encapsulated in the

polymer. In some embodiments, at least 20% of the surface area of the active agent is encapsulated in the polymer. In some embodiments, at least 25% of the surface area of the active agent is encapsulated in the polymer. In some embodiments, at least 30% of the surface area of the active agent is encapsulated in the polymer. In some embodiments, at least 40% of the surface area of the active agent is encapsulated in the polymer. In some embodiments, at least 50% of the surface area of the active agent is encapsulated in the polymer. In some embodiments, at least 60% of the surface area of the active agent is encapsulated in the polymer. In some embodiments, at least 70% of the surface area of the active agent is encapsulated in the polymer. In some embodiments, at least 75% of the surface area of the active agent is encapsulated in the polymer. In some embodiments, at least 80% of the surface area of the active agent is encapsulated in the polymer. In some embodiments, at least 90% of the surface area of the active agent is encapsulated in the polymer. In some embodiments, at least 95% of the surface area of the active agent is at least partially surrounded by the polymer, at least 10% of the surface area of the active agent is at least partially surrounded by the polymer, at least 15% of the surface area of the active agent is at least partially surrounded by the polymer, at least 20% of the surface area of the active agent is at least partially surrounded by the polymer, at least 25% of the surface area of the active agent is at least partially surrounded by the polymer, at least 30% of the surface area of the active agent is at least partially surrounded by the polymer, at least 40% of the surface area of the active agent is at least partially surrounded by the polymer, at least 50% of the surface area of the active agent is at least partially surrounded by the polymer, at least 60% of the surface area of the active agent is at least partially surrounded by the polymer, at least 70% of the surface area of the active agent is at least partially surrounded by the polymer, at least 75% of the surface area of the active agent is at least partially surrounded by the polymer, at least 80% of the surface area of the active agent is at least partially surrounded by the polymer, at least 90% of the surface area of the active agent is at least partially surrounded by the polymer, and at least 95% of the surface area of the active agent is at least partially surrounded by the polymer.

[0033] Provided herein is a coated medical device comprising: a medical device for delivering an active agent to a treatment site; and a coating on the device comprising the active agent, wherein the coated medical device delivers at least a portion of the coating to the treatment site which portion releases active agent into the treatment site over at least about 1 day.

[0034] Provided herein is a coating for a medical device comprising an active agent, wherein the coating delivers the into a treatment site over at least about 1 day.

[0035] Provided herein is a method of forming coating on a medical device with of an active agent comprising depositing the active agent on the medical device using an eSTAT process.

[0036] In some embodiments of the devices, coatings and/or methods provided herein the polymer comprises PLGA. The PLGA may have at least one of: a MW of about 30 KDa and a Mn of about 15 KDa, a Mn of about 10 KDa to about 25 KDa, and a MW of about 15 KDa to about 40 KDa.

[0037] In some embodiments of the methods and/or devices provided herein, the coating comprises a bioabsorb-

able polymer. In some embodiments, the active agent comprises a bioabsorbable polymer. In some embodiments, the bioabsorbable polymer comprises at least one of: Polylactides (PLA); PLGA (poly(lactide-co-glycolide)); Poly-anhydrides; Polyorthoesters; Poly(N-(2-hydroxypropyl) methacrylamide); DLPLA—poly(dl-lactide); LPLA—poly(l-lactide); PGA—polyglycolide; PDO—poly(dioxanone); PGA-TMC—poly(glycolide-co-trimethylene carbonate); PGA-LPLA—poly(l-lactide-co-glycolide); PGA-DLPLA—poly(dl-lactide-co-glycolide); LPLA-DLPLA—poly(l-lactide-co-dl-lactide); and PDO-PGA-TMC—poly(glycolide-co-trimethylene carbonate-co-dioxanone), and combinations, copolymers, and derivatives thereof. In some embodiments, the bioabsorbable polymer comprises between 1% and 95% glycolic acid content PLGA-based polymer.

[0038] In some embodiments of the methods and/or devices provided herein, the polymer comprises at least one of polycarboxylic acids, cellulosic polymers, proteins, polypeptides, polyvinylpyrrolidone, maleic anhydride polymers, polyamides, polyvinyl alcohols, polyethylene oxides, glycosaminoglycans, polysaccharides, polyesters, aliphatic polyesters, polyurethanes, polystyrenes, copolymers, silicones, silicone containing polymers, polyalkyl siloxanes, polyorthoesters, poly-anhydrides, copolymers of vinyl monomers, polycarbonates, polyethylenes, polypropylenes, polylactic acids, polylactides, polyglycolic acids, polyglycolides, polylactide-co-glycolides, polycaprolactones, poly(ϵ -caprolactone)s, polyhydroxybutyrate valerates, polyacrylamides, polyethers, polyurethane dispersions, polyacrylates, acrylic latex dispersions, polyacrylic acid, polyalkyl methacrylates, polyalkylene-co-vinyl acetates, polyalkylenes, aliphatic polycarbonates polyhydroxyalkanoates, polytetrahaloalkylenes, poly(phosphasones), polytetrahaloalkylenes, poly(phosphasones), and mixtures, combinations, and copolymers thereof. The polymers of the present invention may be natural or synthetic in origin, including gelatin, chitosan, dextrin, cyclodextrin, Poly(urethanes), Poly(siloxanes) or silicones, Poly(acrylates) such as poly(methyl methacrylate), poly(butyl methacrylate), and Poly(2-hydroxy ethyl methacrylate), Poly(vinyl alcohol) Poly(olefins) such as poly(ethylene), poly(isoprene), halogenated polymers such as Poly(tetrafluoroethylene)- and derivatives and copolymers such as those commonly sold as Teflon(R) products, Poly(vinylidene fluoride), Poly(vinyl acetate), Poly(vinyl pyrrolidone), Poly(acrylic acid), Polyacrylamide, Poly(ethylene-co-vinyl acetate), Poly(ethylene glycol), Poly(propylene glycol), Poly(methacrylic acid); etc. Suitable polymers also include absorbable and/or resorbable polymers including the following, combinations, copolymers and derivatives of the following: Polylactides (PLA), Polyglycolides (PGA), Poly-Lactide-co-glycolides (PLGA), Poly-anhydrides, Polyorthoesters, Poly(N-(2-hydroxypropyl) methacrylamide), Poly(l-aspartamide), including the derivatives DLPLA—poly(dl-lactide); LPLA—poly(l-lactide); PDO—poly(dioxanone); PGA-TMC—poly(glycolide-co-trimethylene carbonate); PGA-LPLA—poly(l-lactide-co-glycolide); PGA-DLPLA—poly(dl-lactide-co-glycolide); LPLA-DLPLA—poly(l-lactide-co-dl-lactide); and PDO-PGA-TMC—poly(glycolide-co-trimethylene carbonate-co-dioxanone), and combinations thereof.

[0039] In some embodiments of the methods and/or devices provided herein, the polymer has a dry modulus between 3,000 and 12,000 KPa. In some embodiments, the polymer is capable of becoming soft after implantation. In

some embodiments, the polymer is capable of becoming soft after implantation by hydration, degradation or by a combination of hydration and degradation. In some embodiments, the polymer is adapted to transfer, free, and/or dissociate from the substrate when at the intervention site due to hydrolysis of the polymer.

[0040] In some embodiments of the methods and/or devices provided herein, the bioabsorbable polymer is capable of resorption in at least one of: about 1 day, about 3 days, about 5 days, about 7 days, about 14 days, about 3 weeks, about 4 weeks, about 45 days, about 60 days, about 90 days, about 180 days, about 6 months, about 9 months, about 1 year, about 1 to about 2 days, about 1 to about 5 days, about 1 to about 2 weeks, about 2 to about 4 weeks, about 45 to about 60 days, about 45 to about 90 days, about 30 to about 90 days, about 60 to about 90 days, about 90 to about 180 days, about 60 to about 180 days, about 180 to about 365 days, about 6 months to about 9 months, about 9 months to about 12 months, about 9 months to about 15 months, and about 1 year to about 2 years.

[0041] In some embodiments of the methods and/or devices provided herein, the coating comprises a microstructure. In some embodiments, particles of the active agent are sequestered or encapsulated within the microstructure. In some embodiments, the microstructure comprises microchannels, micropores and/or microcavities. In some embodiments, the microstructure is selected to allow sustained release of the active agent. In some embodiments, the microstructure is selected to allow controlled release of the active agent.

[0042] In some embodiments of the devices, coatings and/or methods provided herein the coating comprises a positive surface charge. The positive surface charge may be about 20 mV to about 40 mV. The positive surface charge may be at least one of: at least about 1 mV, over about 1 mV, at least about 5 mV, at least about 10 mV, about 10 mV to about 50 mV, about 20 mV to about 50 mV, about 10 mV to about 40 mV, about 30 mV to about 40 mV, about 20 mV to about 30 mV, and about 25 mV to about 35 mV.

[0043] In some embodiments of the devices, coatings and/or methods provided herein, the w/w percent of active agent in the encapsulated active agent is about 5%. In some embodiments of the devices, coatings and/or methods provided herein, the w/w percent of active agent in the encapsulated active agent is about 10-25%.

[0044] In some embodiments, the encapsulated active agent comprises a polymer at least partially encapsulating at least a portion of an active agent wherein the encapsulated active agent has a positive surface charge. In some embodiments, the active agent is not completely encapsulated. An active agent (or a portion thereof) need not be completely surrounded in order to be encapsulated by the polymer. In some embodiments, at least 10% of the surface area of the active agent is encapsulated in the polymer. In some embodiments, at least 20% of the surface area of the active agent is encapsulated in the polymer. In some embodiments, at least 25% of the surface area of the active agent is encapsulated in the polymer. In some embodiments, at least 30% of the surface area of the active agent is encapsulated in the polymer. In some embodiments, at least 40% of the surface area of the active agent is encapsulated in the polymer. In some embodiments, at least 50% of the surface area of the active agent is encapsulated in the polymer. In some embodiments, at least 60% of the surface area of the active agent is encapsulated in

the polymer. In some embodiments, at least 70% of the surface area of the active agent is encapsulated in the polymer. In some embodiments, at least 75% of the surface area of the active agent is encapsulated in the polymer. In some embodiments, at least 80% of the surface area of the active agent is encapsulated in the polymer. In some embodiments, at least 90% of the surface area of the active agent is encapsulated in the polymer. In some embodiments, at least 95% of the surface area of the active agent is encapsulated in the polymer. In some embodiments, at least one of: at least 5% of the surface area of the active agent is at least partially surrounded by the polymer, at least 10% of the surface area of the active agent is at least partially surrounded by the polymer, at least 15% of the surface area of the active agent is at least partially surrounded by the polymer, at least 20% of the surface area of the active agent is at least partially surrounded by the polymer, at least 25% of the surface area of the active agent is at least partially surrounded by the polymer, at least 30% of the surface area of the active agent is at least partially surrounded by the polymer, at least 40% of the surface area of the active agent is at least partially surrounded by the polymer, at least 50% of the surface area of the active agent is at least partially surrounded by the polymer, at least 60% of the surface area of the active agent is at least partially surrounded by the polymer, at least 70% of the surface area of the active agent is at least partially surrounded by the polymer, at least 75% of the surface area of the active agent is at least partially surrounded by the polymer, at least 80% of the surface area of the active agent is at least partially surrounded by the polymer, at least 90% of the surface area of the active agent is at least partially surrounded by the polymer, and at least 95% of the surface area of the active agent is at least partially surrounded by the polymer.

[0045] In some embodiments of the devices, coatings and/or methods provided herein, at least a portion of the encapsulated active agent are nanoparticles. At least a portion of the encapsulated active agent may be at least one of: a spherical shape, a discoidal shape, a hemispherical shape, a cylindrical shape, a conical shape, a nanoreef shape, a nanobox shape, a cluster shape, a nanotube shape, a whisker shape, a rod shape, a fiber shape, a cup shape, a jack shape, a hexagonal shape, an ellipsoid shape, an oblate ellipsoid shape, a prolate ellipsoid shape, a torus shape, a spheroid shape, a taco-like shape, a bullet shape, a barrel shape, a lens shape, a capsule shape, a pulley wheel shape, a circular disc shape, a rectangular disc shape, a hexagonal disc shape, a flying saucer-like shape, a worm shape, a ribbon-like shape, and a ravioli-like shape.

[0046] The active agent in some embodiments of the devices, coatings and/or methods provided herein comprises a macrolide immunosuppressive drug. The active agent may be selected from sirolimus, a prodrug, a hydrate, an ester, a salt, a polymorph, a derivative, and an analog thereof. A portion of the active agent may be in crystalline form.

[0047] The active agent may be, on average, at least one of: at most 5 microns, over 1 micrometer, between 1 micrometer and 5 micrometers, about 1.5 micrometers on average, and about 2.5 micrometers on average. In some embodiments, the size of the active agent in the coating is controlled in order to improve drug retention in the artery. For non-limiting example, in the case of sirolimus as an active agent, the sirolimus may have an average size of at least one of: 1.5 μm , 2.5 μm , 645 nm, 100-200 nm, another controlled size, or a combination thereof. In some embodiments the size of the active agent is controlled. In some embodiments, the active

agent is sirolimus and wherein the sirolimus has a median size of at least one of: 1.5 μm , 2.5 μm , 645 nm, 100-200 nm, another controlled size, or a combination thereof. In some embodiments, the active agent is sirolimus and wherein the sirolimus has an average size of at least one of: about 1.5 μm , about 2.5 μm , about 645 nm, about 100-200 nm, another controlled size, or a combination thereof. In some embodiments, the active agent is sirolimus and wherein the sirolimus has a median size of at least one of: about 1.5 μm , about 2.5 μm , about 645 nm, about 100-200 nm, another controlled size, or a combination thereof. For example, in some embodiments, sirolimus is the active agent and at least 75% of the sirolimus as is 1.5 μm , 2.5 μm , 645 nm, 100-200 nm, or another controlled size. In some embodiments, sirolimus is the active agent and at least 50% of the sirolimus as is 1.5 μm , 2.5 μm , 645 nm, 100-200 nm, or another controlled size. In some embodiments, sirolimus is the active agent and at least 90% of the sirolimus as is 1.5 μm , 2.5 μm , 645 nm, 100-200 nm, or another controlled size. In some embodiments, sirolimus is the active agent and at least 95% of the sirolimus as is 1.5 μm , 2.5 μm , 645 nm, 100-200 nm, or another controlled size. In some embodiments, sirolimus is the active agent and at least 98% of the sirolimus as is 1.5 μm , 2.5 μm , 645 nm, 100-200 nm, or another controlled size. In some embodiments, sirolimus is the active agent and at least 99% of the sirolimus as is 1.5 μm , 2.5 μm , 645 nm, 100-200 nm, or another controlled size.

[0048] In some embodiments of the devices, coatings and/or methods provided herein the coating delivers the active agent to the treatment site over at least about 1 day. In some embodiments of the devices, coatings and/or methods provided herein the coating delivers the active agent to the treatment site over at least one of: about 3 days, about 5 days, about 1 week, about 1.5 weeks, about 2 weeks, about 14 days, about 3 weeks, about 21 days, about 4 weeks, about 28 days, about 1 month, about 1.5 months, about 2 months, at least about 3 days, at least about 5 days, at least about 1 week, at least about 1.5 weeks, at least about 2 weeks, at least about 14 days, at least about 3 weeks, at least about 21 days, at least about 4 weeks, at least about 28 days, at least about 1 month, at least about 1.5 months, at least about 2 months, about 7 to about 14 days, about 14 to about 21 days, about 14 to about 28 days, about 21 to about 28 days, and about 7 to about 28 days.

[0049] In some embodiments of the devices, coatings and/or methods provided herein the treatment site is a vessel wall. In some embodiments of the devices, coatings and/or methods provided herein the treatment site is a coronary artery. In some embodiments of the devices, coatings and/or methods provided herein the treatment site is bypass graft. In some embodiments of the devices, coatings and/or methods provided herein the treatment site is a bifurcated lesion. In some embodiments of the devices, coatings and/or methods provided herein the treatment site is a small coronary lesions (for example, with reference diameter <2.5 mm). In some embodiments of the devices, coatings and/or methods provided herein the treatment site is a peripheral artery. In some embodiments of the devices, coatings and/or methods provided herein the treatment site is vein. In some embodiments of the devices, coatings and/or methods provided herein the treatment site is an AV graft. In some embodiments of the devices, coatings and/or methods provided herein the treatment site is an AV fistula. In some embodiments of the devices, coatings and/or methods provided herein the treatment site is a biliary tract. In some embodiments of the

devices, coatings and/or methods provided herein the treatment site is a biliary duct. In some embodiments of the devices, coatings and/or methods provided herein the treatment site is a sinus. In some embodiments of the devices, coatings and/or methods provided herein the treatment site is a vein graft.

[0050] In some embodiments of the devices, coatings and/or methods provided herein the coating comprises a positive surface charge on a surface of the coating configured to contact the treatment site.

[0051] In some embodiments of the devices, coatings and/or methods provided herein the encapsulated active agent are micelles.

[0052] In some embodiments of the devices, coatings and/or methods provided herein the medical device comprises a balloon. In some embodiments the medical device is a balloon of a balloon catheter.

[0053] In some embodiments of the devices, coatings and/or methods provided herein depositing the encapsulated active agent comprises using an eSTAT process. In some embodiments of the devices, coatings and/or methods provided herein depositing a second polymer on the medical device following depositing the encapsulated active agent on the medical device.

[0054] In some embodiments of the methods and/or devices provided herein, the coating is formed on the substrate by a process comprising depositing a polymer and/or the active agent by an RESS, e-RESS, an e-SEDS, or an e-DPC process. In some embodiments of the methods and/or devices provided herein, wherein the coating is formed on the substrate by a process comprising at least one of: depositing a polymer by an RESS, e-RESS, an e-SEDS, or an e-DPC process, and depositing the pharmaceutical agent by an e-RESS, an e-SEDS, eSTAT, or an e-DPC process. In some embodiments of the methods and/or devices provided herein, the coating is formed on the substrate by a process comprising at least one of: depositing a polymer by an RESS, e-RESS, an e-SEDS, or an e-DPC process, and depositing the active agent by an eSTAT, e-RESS, an e-SEDS, or an e-DPC process. In some embodiments, the process of forming the coating provides improved adherence of the coating to the substrate prior to deployment of the device at the intervention site and facilitates dissociation of the coating from the substrate at the intervention site. In some embodiments, the coating is formed on the substrate by a process comprising depositing the active agent by an eSTAT, e-RESS, an e-SEDS, or an e-DPC process without electrically charging the substrate. In some embodiments, the coating is formed on the substrate by a process comprising depositing the active agent on the substrate by an e-RESS, an e-SEDS, or an e-DPC process without creating an electrical potential between the substrate and a coating apparatus used to deposit the coating.

[0055] In some embodiments of the devices, coatings and/or methods provided herein the second polymer comprises PLGA. The PLGA may have at least one of: a MW of about 30 KDa and a Mn of about 15 KDa, a Mn of about 10 KDa to about 25 KDa, and a MW of about 15 KDa to about 40 KDa. Depositing the second polymer on the medical device may use at least one of a RESS coating process, an eSTAT coating process, a dip coating process, and a spray coating process.

[0056] In some embodiments of the methods and/or devices provided herein, the intervention site is in or on the body of a subject. In some embodiments, the intervention site is a vascular wall. In some embodiments, the intervention site

is a non-vascular lumen wall. In some embodiments, the intervention site is a vascular cavity wall. In some embodiments of the methods and/or devices provided herein, the intervention site is a wall of a body cavity. In some embodiments, the body cavity is the result of a lumpectomy. In some embodiments, the intervention site is a cannulized site within a subject. In some embodiments of the methods and/or devices provided herein, the intervention site is a sinus wall. In some embodiments, the intervention site is a sinus cavity wall. In some embodiments, the active agent comprises a corticosteroid.

[0057] In some embodiments of the methods and/or devices provided herein, the coating is capable of at least one of: retarding healing, delaying healing, and preventing healing. In some embodiments, the coating is capable of at least one of: retarding, delaying, and preventing the inflammatory phase of healing. In some embodiments, the coating is capable of at least one of: retarding, delaying, and preventing the proliferative phase of healing. In some embodiments, the coating is capable of at least one of: retarding, delaying, and preventing the maturation phase of healing. In some embodiments, the coating is capable of at least one of: retarding, delaying, and preventing the remodeling phase of healing. In some embodiments, the active agent comprises an anti-angiogenic agent.

[0058] Provided herein is a method comprising providing a medical device, wherein the medical device comprises a substrate and a coating on at least a portion of the substrate, and wherein the coating comprises a plurality of layers, wherein at least one layer comprises a pharmaceutical agent in a therapeutically desirable morphology, and transferring at least a portion of the coating from the substrate to the intervention site upon stimulating the coating with a stimulation.

[0059] Provided herein is a medical device comprising: an invertable balloon; and a coating on an abluminal side of the invertable balloon, wherein the coating comprises an active agent and a binding agent, and wherein the device releases at least 3% of the active agent to artery upon inflation of the balloon in vivo. In some embodiments, the balloon is inverted such that the abluminal side of the balloon is protected from blood flow during tracking to the treatment site. In some embodiments, the balloon is inverted such that the abluminal side of the balloon is protected from blood flow during tracking to the treatment site. In some embodiments, the balloon is inverted on the outside of the catheter. In some embodiments, the balloon is capable of being un-inverted such that the abluminal surface is positioned within the treatment site. In some embodiments, the balloon is inverted within a catheter. In some embodiments, the balloon is capable of being pushed out of the catheter using balloon inflation pressure. In some embodiments, the balloon is capable of being pushed out of the catheter by moving the distal end of the balloon distally through the balloon. In some embodiments, the balloon unrolls into the treatment site such that the coated portion of the balloon is adjacent the treatment site. In some embodiments, the balloon is partially un-inverted at the treatment site. In some embodiments, the treatment length of the balloon is controlled by partially un-inverting balloon outside of a catheter in which it was inverted.

[0060] Provided herein is method comprising providing an invertable balloon comprising a coating on an abluminal side of the invertable balloon, wherein the coating comprises an active agent and a binding agent, and un-inverting the invertable balloon to expose the coating or a portion thereof to a

treatment site, wherein the device releases at least 3% of the active agent to artery upon inflation of the balloon in vivo. In some embodiments, the abluminal side of the balloon is protected from blood flow during tracking to the treatment site. In some embodiments, the balloon is inverted on the outside of the catheter. In some embodiments, the balloon is capable of being un-inverted such that the abluminal surface is positioned within the treatment site. In some embodiments, the balloon is inverted within a catheter. In some embodiments, the balloon is capable of being pushed out of the catheter using balloon inflation pressure. In some embodiments, the balloon is capable of being pushed out of the catheter by moving the distal end of the balloon distally through the balloon. In some embodiments, the balloon unrolls into the treatment site such that the coated portion of the balloon is adjacent the treatment site. The method may comprise partially un-inverting the balloon at the treatment site. The method may comprise controlling a treatment length of the balloon by partially un-inverting balloon outside of a catheter in which it was inverted.

[0061] Provided herein is a medical device comprising: a balloon; and a coating on an abluminal side of the balloon, a sheath over the balloon wherein the coating comprises an active agent and a binding agent, and wherein the device releases at least 3% of the active agent to artery upon inflation of the balloon in vivo. In some embodiments, the sheath is retractable. In some embodiments, the sheath covers the coated balloon until the balloon reaches the treatment site. In some embodiments, the sheath is retractable once the coated balloon is positioned near the treatment site. In some embodiments, the sheath is retractable once the coated balloon is positioned at the treatment site. In some embodiments, the sheath covers the coated balloon until the balloon is proximal to the treatment site. In some embodiments, the sheath covers the coated balloon until the balloon is distal to the treatment site. In some embodiments, the sheath covers the coated balloon until the balloon is within to the treatment site. In some embodiments, the sheath may be moved over the balloon following deflation of the balloon after the coating has been released to the artery. In some embodiments, the sheath may be moved over the balloon following deflation of the balloon after a portion of the coating has been released to the artery.

[0062] Provided herein is method comprising: providing a balloon comprising a coating on an abluminal side of the balloon, and providing a sheath over the balloon, wherein the coating comprises an active agent and a binding agent, and wherein the device releases at least 3% of the active agent to artery upon inflation of the balloon in vivo. The method may comprise retracting the sheath. The method may comprise keeping the sheath over the balloon until the balloon reaches the treatment site. The method may comprise keeping the sheath over the balloon until the coated balloon is positioned near the treatment site. The method may comprise keeping the sheath over the balloon until the coated balloon is positioned at the treatment site. The method may comprise keeping the sheath over the balloon until the balloon is proximal to the treatment site. The method may comprise keeping the sheath over the balloon until the balloon is distal to the treatment site. The method may comprise keeping the sheath over the balloon until the balloon is within to the treatment site. The method may comprise moving the sheath over the balloon after the coating has been released to the artery. The

method may comprise moving the sheath over the balloon after a portion of the coating has been released to the artery.

[0063] Provided herein is a medical device comprising: a balloon; and a coating on the balloon, and an occluder, wherein the coating comprises an active agent and a binding agent, and wherein the device releases at least 3% of the active agent to artery upon inflation of the balloon in vivo. In some embodiments, the occluder is a flow occluder. In some embodiments, the occluder configured to block the flow of bodily fluids at a treatment site during exposure of the coating to the treatment site. In some embodiments, the occluder comprises a second balloon that occludes the flow of the blood at the treatment site. In some embodiments, the balloon comprises the occluder. In some embodiments, the balloon has two sections, a first section comprising the occluder and a second section comprising the coating. In some embodiments, the balloon comprises a distal node and a proximal node. In some embodiments, the distal node comprises the coating and wherein the proximal node comprises the occluder. In some embodiments, the proximal node comprises the coating and wherein the distal node comprises the occluder. In some embodiments, the occluder is located proximally from the balloon. In some embodiments, the occluder is located proximally from the coating. In some embodiments, the occluder is the appropriate shape to occlude flow of blood at the treatment site. In some embodiments, the occluder substantially conforms to the shape of a treatment area near a treatment site such fluid flow at the treatment site is occluded. In some embodiments, a distal portion of the balloon is coated and wherein a proximal portion of the balloon is not coated, and wherein the proximal portion of the balloon is the occluder. In some embodiments, a proximal portion of the balloon is coated and wherein a distal portion of the balloon is not coated, and wherein the distal portion of the balloon is the occluder. In some embodiments, a second balloon comprises the occluder. In some embodiments, the balloon and the second balloon have separate inflation lumens. In some embodiments, the balloon and the second balloon share an inflation lumen. In some embodiments, the occluder is located proximally from the coating. In some embodiments, the occluder is located distally from the coating. In some embodiments, the occluder occludes the flow of the fluid at the treatment prior to expansion of the balloon having coating thereon. In some embodiments, the occluder is deployable. In some embodiments, the occluder is deployable separately from the balloon. In some embodiments, the occluder is retractable. In some embodiments, the occluder comprises a second coating. In some embodiments, the second coating comprises at least one of an active agent and a polymer.

[0064] Provided herein is method comprising providing a balloon comprising a coating on the balloon, wherein the coating comprises an active agent and a binding agent, providing an occluder, wherein the device releases at least 3% of the active agent to artery upon inflation of the balloon in vivo. In some embodiments, the occluder is a flow occluder. In some embodiments, the occluder configured to block the flow of bodily fluids at a treatment site during exposure of the coating to the treatment site. In some embodiments, the occluder comprises a second balloon that occludes the flow of the blood at the treatment site. In some embodiments, the balloon comprises the occluder. In some embodiments, the balloon has two sections, a first section comprising the occluder and a second section comprising the coating. In

some embodiments, the balloon comprises a distal node and a proximal node. In some embodiments, the distal node comprises the coating and wherein the proximal node comprises the occluder. In some embodiments, the proximal node comprises the coating and wherein the distal node comprises the occluder. In some embodiments, the occluder is located proximally from the balloon. In some embodiments, the occluder is located proximally from the coating. In some embodiments, the occluder is the appropriate shape to occlude flow of blood at the treatment site. In some embodiments, the occluder substantially conforms to the shape of a treatment area near a treatment site such fluid flow at the treatment site is occluded. In some embodiments, a distal portion of the balloon is coated and wherein a proximal portion of the balloon is not coated, and wherein the proximal portion of the balloon is the occluder. In some embodiments, a proximal portion of the balloon is coated and wherein a distal portion of the balloon is not coated, and wherein the distal portion of the balloon is the occluder. In some embodiments, a second balloon comprises the occluder. In some embodiments, the balloon and the second balloon have separate inflation lumens. In some embodiments, the balloon and the second balloon share an inflation lumen. In some embodiments, the occluder is located proximally from the coating. In some embodiments, the occluder is located distally from the coating. In some embodiments, the occluder occludes the flow of fluid at a treatment prior to expansion of the balloon having coating thereon. The method may comprise deploying the occluder. In some embodiments, the occluder is deployable separately from the balloon. The method may comprise retracting the occluder. In some embodiments, the occluder comprises a second coating. In some embodiments, the second coating comprises at least one of an active agent and a polymer.

[0065] In some embodiments of the devices, methods or coatings herein, the device releases at least one of: at least 5% of the active agent to artery upon inflation of the balloon in vivo, at least 7% of the active agent to artery upon inflation of the balloon in vivo, at least 10% of the active agent to artery upon inflation of the balloon in vivo, at least 15% of the active agent to artery upon inflation of the balloon in vivo, at least 20% of the active agent to artery upon inflation of the balloon in vivo, at least 25% of the active agent to artery upon inflation of the balloon in vivo, at least 30% of the active agent to artery upon inflation of the balloon in vivo, at least 40% of the active agent to artery upon inflation of the balloon in vivo, at least 50% of the active agent to artery upon inflation of the balloon in vivo, between 2% and 50% of the active agent to artery upon inflation of the balloon in vivo, between 3% and 50% of the active agent to artery upon inflation of the balloon in vivo, between 5% and 50% of the active agent to artery upon inflation of the balloon in vivo, between 3% and 30% of the active agent to artery upon inflation of the balloon in vivo, between 3% and 25% of the active agent to artery upon inflation of the balloon in vivo, between 3% and 20% of the active agent to artery upon inflation of the balloon in vivo, between 3% and 15% of the active agent to artery upon inflation of the balloon in vivo, between 1% and 15% of the active agent to artery upon inflation of the balloon in vivo, between 1% and 10% of the active agent to artery upon inflation of the balloon in vivo, between 3% and 10% of the

active agent to artery upon inflation of the balloon in vivo, and between 1% and 5% of the active agent to artery upon inflation of the balloon in vivo.

[0066] In some embodiments of the devices, methods or coatings herein, at least one of: at most 1% of coating is removed from the balloon due to tracking of the coated balloon to the treatment site, at most 5% of coating is removed from the balloon due to tracking of the coated balloon to the treatment site, at most 10% of coating is removed from the balloon due to tracking of the coated balloon to the treatment site, at most 15% of coating is removed from the balloon due to tracking of the coated balloon to the treatment site, at most 20% of coating is removed from the balloon due to tracking of the coated balloon to the treatment site, at most 25% of coating is removed from the balloon due to tracking of the coated balloon to the treatment site, and at most 30% of coating is removed from the balloon due to tracking of the coated balloon to the treatment site.

INCORPORATION BY REFERENCE

[0067] All publications and patent applications mentioned in this specification are herein incorporated by reference to the same extent as if each individual publication or patent application was specifically and individually indicated to be incorporated by reference. This application relates to U.S. Provisional Application No. 61/081,691, filed Jul. 17, 2008, U.S. Provisional Application No. 61/226,239 filed Jul. 16, 2009, U.S. Provisional Application No. 61/212,964, filed Apr. 17, 2009, U.S. application Ser. No. 12/504,597, filed Jul. 16, 2009, U.S. application Ser. No. 12/729,580, filed Mar. 23, 2010, PCT Application No. PCT/US2009/050883, filed Jul. 16, 2009, PCT Application No. PCT/US2010/028253, filed Mar. 23, 2010, and PCT Application No. PCT/US2010/042355, filed Jul. 16, 2010. The contents of these applications are incorporated herein by reference in their entirety.

BRIEF DESCRIPTION OF THE DRAWINGS

[0068] The novel features of the invention are set forth with particularity in the appended claims. A better understanding of the features and advantages of the present invention will be obtained by reference to the following detailed description that sets forth illustrative embodiments, in which the principles of the invention are utilized, and the accompanying drawings of which:

[0069] FIG. 1 indicates the Average percent Sirolimus Eluted from the balloons at various time points for Formulations F3, F5, and F7.

[0070] FIG. 2 depicts an example eSTAT process for coating 12 angioplasty balloons with sirolimus.

[0071] FIG. 3 depicts coating balloons according to an RESS process.

DETAILED DESCRIPTION OF THE INVENTION

[0072] The present invention is explained in greater detail below. This description is not intended to be a detailed catalog of all the different ways in which the invention may be implemented, or all the features that may be added to the instant invention. For example, features illustrated with respect to one embodiment may be incorporated into other embodiments, and features illustrated with respect to a particular embodiment may be deleted from that embodiment. In addition, numerous variations and additions to the various embodiments suggested herein will be apparent to those

skilled in the art in light of the instant disclosure, which do not depart from the instant invention. Hence, the following specification is intended to illustrate some particular embodiments of the invention, and not to exhaustively specify all permutations, combinations and variations thereof.

DEFINITIONS

[0073] As used in the present specification, the following words and phrases are generally intended to have the meanings as set forth below, except to the extent that the context in which they are used indicates otherwise.

[0074] “Substrate” as used herein, refers to any surface upon which it is desirable to deposit a coating. Biomedical implants are of particular interest for the present invention; however the present invention is not intended to be restricted to this class of substrates. Those of skill in the art will appreciate alternate substrates that could benefit from the coating process described herein, such as pharmaceutical tablet cores, as part of an assay apparatus or as components in a diagnostic kit (e.g. a test strip). Examples of substrates that can be coated using the methods of the invention include surgery devices or medical devices, e.g., a catheter, a balloon, a cutting balloon, a wire guide, a cannula, tooling, an orthopedic device, a structural implant, stent, stent-graft, graft, vena cava filter, a heart valve, cerebrospinal fluid shunts, pacemaker electrodes, axius coronary shunts, endocardial leads, an artificial heart, and the like.

[0075] “Biomedical implant” as used herein refers to any implant for insertion into the body of a human or animal subject, including but not limited to stents (e.g., coronary stents, vascular stents including peripheral stents and graft stents, urinary tract stents, urethral/prostatic stents, rectal stent, oesophageal stent, biliary stent, pancreatic stent), electrodes, catheters, leads, implantable pacemaker, cardioverter or defibrillator housings, joints, screws, rods, ophthalmic implants, femoral pins, bone plates, grafts, anastomotic devices, perivascular wraps, sutures, staples, shunts for hydrocephalus, dialysis grafts, colostomy bag attachment devices, ear drainage tubes, leads for pace makers and implantable cardioverters and defibrillators, vertebral disks, bone pins, suture anchors, hemostatic barriers, clamps, screws, plates, clips, vascular implants, tissue adhesives and sealants, tissue scaffolds, various types of dressings (e.g., wound dressings), bone substitutes, intraluminal devices, vascular supports, etc.

[0076] The implants may be formed from any suitable material, including but not limited to polymers (including stable or inert polymers, organic polymers, organic-inorganic copolymers, inorganic polymers, and biodegradable polymers), metals, metal alloys, inorganic materials such as silicon, and composites thereof, including layered structures with a core of one material and one or more coatings of a different material. Substrates made of a conducting material facilitate electrostatic capture. However, the invention contemplates the use of electrostatic capture, as described herein, in conjunction with substrate having low conductivity or which are non-conductive. To enhance electrostatic capture when a non-conductive substrate is employed, the substrate is processed for example while maintaining a strong electrical field in the vicinity of the substrate. In some embodiments, however, no electrostatic capture is employed in applying a coating to the substrate. In some embodiments of the methods and/or devices provided herein, the substrate is not charged in the coating process. In some embodiments of the methods

and/or devices provided herein, an electrical potential is not created between the substrate and the coating apparatus.

[0077] Subjects into which biomedical implants of the invention may be applied or inserted include both human subjects (including male and female subjects and infant, juvenile, adolescent, adult and geriatric subjects) as well as animal subjects (including but not limited to pig, rabbit, mouse, dog, cat, horse, monkey, etc.) for veterinary purposes and/or medical research.

[0078] As used herein, a biological implant may include a medical device that is not permanently implanted. A biological implant in some embodiments may comprise a device which is used in a subject on a transient basis. For non-limiting example, the biomedical implant may be a balloon, which is used transiently to dilate a lumen and thereafter may be deflated and/or removed from the subject during the medical procedure or thereafter. In some embodiments, the biological implant may be temporarily implanted for a limited time, such as during a portion of a medical procedure, or for only a limited time (some time less than permanently implanted), or may be transiently implanted and/or momentarily placed in the subject. In some embodiments, the biological implant is not implanted at all, rather it is merely inserted into a subject during a medical procedure, and subsequently removed from the subject prior to or at the time the medical procedure is completed. In some embodiments, the biological implant is not permanently implanted since it completely resorbs into the subject (i.e. is completely resorbed by the subject). In a preferred embodiment the biomedical implant is an expandable balloon that can be expanded within a lumen (naturally occurring or non-naturally occurring) having a coating thereon that is freed (at least in part) from the balloon and left behind in the lumen when the balloon is removed from the lumen.

[0079] Examples of pharmaceutical agents employed in conjunction with the invention include, rapamycin, 40-O-(2-Hydroxyethyl)rapamycin (everolimus), 40-O-Benzyl-rapamycin, 40-O-(4'-Hydroxymethyl)benzyl-rapamycin, 40-O-[4'-(1,2-Dihydroxyethyl)]benzyl-rapamycin, 40-O-Allyl-rapamycin, 40-O-[3'-(2,2-Dimethyl-1,3-dioxolan-4(S)-yl)-prop-2'-en-1'-yl]-rapamycin, (2':E,4'S)-40-O-(4',5'-Dihydroxypent-2'-en-1'-yl)-rapamycin 40-O-(2-Hydroxy)ethoxycar-bonylmethyl-rapamycin, 40-O-(3-Hydroxy)propyl-rapamycin 40—O-(6-Hydroxy)hexyl-rapamycin 40-O-[2-(2-Hydroxy)ethoxy]ethyl-rapamycin 40—O-[(3S)-2,2-Dimethyldioxolan-3-yl]methyl-rapamycin, 40-O-[(2S)-2,3-Dihydroxyprop-1-yl]-rapamycin, 40-O-(2-Acetoxy)ethyl-rapamycin 40-O-(2-Nicotinoyloxy)ethyl-rapamycin, 40-O-[2-(N-Morpholino)acetoxy]ethyl-rapamycin 40-O-(2-N-Imidazolylacetoxy)ethyl-rapamycin, 40-O-[2-(N-Methyl-N'-piperazinyl)acetoxy]ethyl-rapamycin, 39-O-Desmethyl-39,40-O, O-ethylene-rapamycin, (26R)-26-Dihydro-40-O-(2-hydroxy)ethyl-rapamycin, 28-O-Methyl-rapamycin, 40—O-(2-Aminoethyl)-rapamycin, 40—O-(2-Acetaminoethyl)-rapamycin 40—O-(2-Nicotinamidoethyl)-rapamycin, 40—O-(2-(N-Methyl-imidazo-2'-ylcarbathoxamido)ethyl)-rapamycin, 40—O-(2-Ethoxycarbonylaminoethyl)-rapamycin, 40-O-(2-Tolylsulfonamidoethyl)-rapamycin, 40-O-[2-(4',5'-Dicarboethoxy-1',2',3'-triazol-1'-yl)-ethyl]-rapamycin, 42-Epi-(tetrazolyl)rapamycin (tacrolimus), and 42-[3-hydroxy-2-(hydroxymethyl)-2-methylpropanoate]rapamycin (temsirolimus). The active agent in some embodiments of the devices, coatings and/or methods provided herein comprises

a macrolide immunosuppressive drug. In some embodiments the macrolide immunosuppressive drug comprises one or more of rapamycin, 40-O-(2-Hydroxyethyl)rapamycin (everolimus), 40-O-Benzyl-rapamycin, 40-O-(4'-Hydroxymethyl)benzyl-rapamycin, 40-O-[4'-(1,2-Dihydroxyethyl)]benzyl-rapamycin, 40-O-Allyl-rapamycin, 40-O-[3'-(2,2-Dimethyl-1,3-dioxolan-4(S)-yl)-prop-2'-en-1'-yl]-rapamycin, (2'E,4'S)-40-O-(4',5'-Dihydroxypent-2'-en-1'-yl)-rapamycin 40-O-(2-Hydroxy)ethoxycarbonylmethyl-rapamycin, 40-O-(3-Hydroxy)propyl-rapamycin 40-O-(6-Hydroxy)hexyl-rapamycin 40-O-[2-(2-Hydroxy)ethoxy]ethyl-rapamycin 40-O-[(3S)-2,2-Dimethyldioxolan-3-yl]methyl-rapamycin, 40-O-[(2S)-2,3-Dihydroxyprop-1-yl]-rapamycin, 40-O-(2-Acetoxy)ethyl-rapamycin 40-O-(2-Nicotinoyloxy)ethyl-rapamycin, 40-O-[2-(N-Morpholino)acetoxy]ethyl-rapamycin 40-O-(2-N-Imidazolylacetoxy)ethyl-rapamycin, 40-O-[2-(N-Methyl-N'-piperaziny)acetoxy]ethyl-rapamycin, 39-O-Desmethyl-39,40-O,O-ethylene-rapamycin, (26R)-26-Dihydro-40-O-(2-hydroxy)ethyl-rapamycin, 28-O-Methyl-rapamycin, 40-O-(2-Aminoethyl)-rapamycin, 40-O-(2-Acetaminoethyl)-rapamycin 40-O-(2-Nicotinamidoethyl)-rapamycin, 40-O-(2-(N-Methyl-imidazo-2'-ylcarbethoxamido)ethyl)-rapamycin, 40-O-(2-Ethoxycarbonylaminoethyl)-rapamycin, 40-O-(2-Tolylsulfonamidoethyl)-rapamycin, 40-O-[2-(4',5'-Dicarboethoxy-1',2',3'-triazol-1'-yl)-ethyl]-rapamycin, 42-Epi-(tetrazolyl)rapamycin (tacrolimus), and 42-[3-hydroxy-2-(hydroxymethyl)-2-methylpropanoate]rapamycin (temsirolimus). The active agent may be selected from a macrolide immunosuppressive drug, a prodrug, a hydrate, an ester, a salt, a polymorph, a derivative, and an analog thereof. The active agent may be selected from sirolimus, a prodrug, a hydrate, an ester, a salt, a polymorph, a derivative, and an analog thereof.

[0080] The pharmaceutical agents may, if desired, also be used in the form of their pharmaceutically acceptable salts or derivatives (meaning salts which retain the biological effectiveness and properties of the compounds of this invention and which are not biologically or otherwise undesirable), and in the case of chiral active ingredients it is possible to employ both optically active isomers and racemates or mixtures of diastereoisomers. As well, the pharmaceutical agent may include at least one of: a prodrug, a hydrate, an ester, a salt, a polymorph, a derivative, and an analog thereof.

[0081] The pharmaceutical agent may be an antibiotic agent, as described herein.

[0082] In some embodiments of the methods, coatings, and/or devices provided herein, the size of the active agent in the coating is controlled. In some embodiments, the active agent is sirolimus and wherein the sirolimus has an average size (mean diameter) of at least one of: 1.5 μm , 2.5 μm , 645 nm, 100-200 nm, another controlled size, or a combination thereof. In some embodiments, the active agent is sirolimus and wherein the sirolimus has a median size of at least one of: 1.5 μm , 2.5 μm , 645 nm, 100-200 nm, another controlled size, or a combination thereof. In some embodiments, the active agent is sirolimus and wherein the sirolimus has an average size (mean diameter) of at least one of: about 1.5 μm , about 2.5 μm , about 645 nm, about 100-200 nm, another controlled size, or a combination thereof. In some embodiments, the active agent is sirolimus and wherein the sirolimus has a median size of at least one of: about 1.5 μm , about 2.5 μm , about 645 nm, about 100-200 nm, another controlled size, or a combination thereof. In some embodiments, the active

agent is sirolimus and wherein sirolimus at least 75% of the sirolimus as is 1.5 μm , 2.5 μm , 645 nm, 100-200 nm, or another controlled size. In some embodiments, the active agent is sirolimus and wherein sirolimus at least 50% of the sirolimus as is 1.5 μm , 2.5 μm , 645 nm, 100-200 nm, or another controlled size. In some embodiments, the active agent is sirolimus and wherein sirolimus at least 90% of the sirolimus as is 1.5 μm , 2.5 μm , 645 nm, 100-200 nm, or another controlled size.

[0083] In some embodiments of the methods and/or devices provided herein, the macrolide immunosuppressive drug is at least 50% crystalline. In some embodiments, the macrolide immunosuppressive drug is at least 75% crystalline. In some embodiments, the macrolide immunosuppressive drug is at least 90% crystalline. In some embodiments of the methods and/or devices provided herein the macrolide immunosuppressive drug is at least 95% crystalline. In some embodiments of the methods and/or devices provided herein the macrolide immunosuppressive drug is at least 97% crystalline. In some embodiments of the methods and/or devices provided herein the macrolide immunosuppressive drug is at least 98% crystalline. In some embodiments of the methods and/or devices provided herein the macrolide immunosuppressive drug is at least 99% crystalline.

[0084] In some embodiments of the methods and/or devices provided herein the pharmaceutical agent is at least 50% crystalline. In some embodiments of the methods and/or devices provided herein the pharmaceutical agent is at least 75% crystalline. In some embodiments of the methods and/or devices provided herein the pharmaceutical agent is at least 90% crystalline. In some embodiments of the methods and/or devices provided herein the pharmaceutical agent is at least 95% crystalline. In some embodiments of the methods and/or devices provided herein the pharmaceutical agent is at least 97% crystalline. In some embodiments of the methods and/or devices provided herein the pharmaceutical agent is at least 98% crystalline. In some embodiments of the methods and/or devices provided herein the pharmaceutical agent is at least 99% crystalline.

[0085] "Prodrugs" are derivative compounds derivatized by the addition of a group that endows greater solubility to the compound desired to be delivered. Once in the body, the prodrug is typically acted upon by an enzyme, e.g., an esterase, amidase, or phosphatase, to generate the active compound.

[0086] An "anti-cancer agent", "anti-tumor agent" or "chemotherapeutic agent" refers to any agent useful in the treatment of a neoplastic condition. There are many chemotherapeutic agents available in commercial use, in clinical evaluation and in pre-clinical development that are useful in the devices and methods of the present invention for treatment of cancers.

[0087] "Stability" as used herein in refers to the stability of the drug in a coating deposited on a substrate in its final product form (e.g., stability of the drug in a coated stent). The term "stability" and/or "stable" in some embodiments is defined by 5% or less degradation of the drug in the final product form. The term stability in some embodiments is defined by 3% or less degradation of the drug in the final product form. The term stability in some embodiments is defined by 2% or less degradation of the drug in the final product form. The term stability in some embodiments is defined by 1% or less degradation of the drug in the final product form.

[0088] In some embodiments, the pharmaceutical agent is at least one of: 50% crystalline, 75% crystalline, 80% crystalline, 90% crystalline, 95% crystalline, 97% crystalline, and 99% crystalline following sterilization of the device. In some embodiments, the pharmaceutical agent crystallinity is stable wherein the crystallinity of the pharmaceutical agent following sterilization is compared to the crystallinity of the pharmaceutical agent at least one of: 1 week after sterilization, 2 weeks after sterilization, 4 weeks after sterilization, 1 month after sterilization, 2 months after sterilization, 45 days after sterilization, 60 days after sterilization, 90 days after sterilization, 3 months after sterilization, 4 months after sterilization, 6 months after sterilization, 9 months after sterilization, 12 months after sterilization, 18 months after sterilization, and 2 years after sterilization. In some embodiments, the pharmaceutical agent crystallinity is stable wherein the crystallinity of the pharmaceutical agent prior to sterilization is compared to the crystallinity of the pharmaceutical agent at least one of: 1 week after sterilization, 2 weeks after sterilization, 4 weeks after sterilization, 1 month after sterilization, 2 months after sterilization, 45 days after sterilization, 60 days after sterilization, 90 days after sterilization, 3 months after sterilization, 4 months after sterilization, 6 months after sterilization, 9 months after sterilization, 12 months after sterilization, 18 months after sterilization, and 2 years after sterilization. In such embodiments, different devices may be tested from the same manufacturing lot to determine stability of the pharmaceutical agent at the desired time points.

[0089] In some embodiments, the pharmaceutical agent crystallinity is stable at least one of: 1 week after sterilization, 2 weeks after sterilization, 4 weeks after sterilization, 1 month after sterilization, 2 months after sterilization, 45 days after sterilization, 60 days after sterilization, 90 days after sterilization, 3 months after sterilization, 4 months after sterilization, 6 months after sterilization, 9 months after sterilization, 12 months after sterilization, 18 months after sterilization, and 2 years after sterilization.

[0090] In some embodiments, the pharmaceutical agent crystallinity on the device tested at a time point after sterilization does not differ more than 1%, 2%, 3%, 4%, and/or 5% from the crystallinity tested on a second device manufactured from the same lot of devices and the same lot of pharmaceutical agent at testing time point before sterilization (i.e. the crystallinity drops no more than from 99 to 94% crystalline, for example, which is a 5% difference in crystallinity; the crystallinity drops no more than from 99 to 95% crystalline, which is a 4% difference in crystallinity; the crystallinity drops no more than from 99 to 96% crystalline, for example, which is a 3% difference in crystallinity; the crystallinity drops no more than from 99 to 97% crystalline, for example, which is a 2% difference in crystallinity; the crystallinity drops no more than from 99 to 98% crystalline, for example, which is a 1% difference in crystallinity; in other examples, the starting crystallinity percentage is one of 100%, 98%, 96%, 97%, 96%, 95%, 90%, 85%, 80%, 75%, 70%, 60%, 50%, 30%, 25%, and/or anything in between).

[0091] In some embodiments, crystallinity of the pharmaceutical agent on the device tested at a time point after sterilization does not differ more than 1%, 2%, 3%, 4%, and/or 5% from the crystallinity of pharmaceutical from the same lot of pharmaceutical agent tested at testing time point before sterilization of the pharmaceutical agent.

[0092] In some embodiments, crystallinity of the pharmaceutical agent does not drop more than 1%, 2%, 3%, 4%,

and/or 5% between two testing time points after sterilization neither of which time point being greater than 2 years after sterilization. In some embodiments, crystallinity of the pharmaceutical agent does not drop more than 1%, 2%, 3%, 4%, and/or 5% between two testing time points after sterilization neither of which time point being greater than 5 years after sterilization. In some embodiments, two time points comprise two of: 1 week after sterilization, 2 weeks after sterilization, 4 weeks after sterilization, 1 month after sterilization, 2 months after sterilization, 45 days after sterilization, 60 days after sterilization, 90 days after sterilization, 3 months after sterilization, 4 months after sterilization, 6 months after sterilization, 9 months after sterilization, 12 months after sterilization, 18 months after sterilization, 2 years after sterilization, 3 years after sterilization, 4 years after sterilization, and 5 years after sterilization.

[0093] "Polymer" as used herein, refers to a series of repeating monomeric units that have been cross-linked or polymerized. Any suitable polymer can be used to carry out the present invention. It is possible that the polymers of the invention may also comprise two, three, four or more different polymers. In some embodiments of the invention only one polymer is used. In certain embodiments a combination of two polymers is used. Combinations of polymers can be in varying ratios, to provide coatings with differing properties. Polymers useful in the devices and methods of the present invention include, for example, stable or inert polymers, organic polymers, organic-inorganic copolymers, inorganic polymers, bioabsorbable, bioresorbable, resorbable, degradable, and biodegradable polymers. Those of skill in the art of polymer chemistry will be familiar with the different properties of polymeric compounds.

[0094] In some embodiments, the coating further comprises a polymer. In some embodiments, the active agent comprises a polymer. In some embodiments, the polymer comprises at least one of polyalkyl methacrylates, polyalkylene-co-vinyl acetates, polyalkylenes, polyurethanes, poly-anhydrides, aliphatic polycarbonates, polyhydroxyalkanoates, silicone containing polymers, polyalkyl siloxanes, aliphatic polyesters, polyglycolides, polylactides, polylactide-co-glycolides, poly(e-caprolactone)s, polytetrahydroalkylenes, polystyrenes, poly(phosphazones), copolymers thereof, and combinations thereof.

[0095] In embodiments, the polymer is capable of becoming soft after implantation, for example, due to hydration, degradation or by a combination of hydration and degradation. In embodiments, the polymer is adapted to transfer, free, and/or dissociate from the substrate when at the intervention site due to hydrolysis of the polymer. In various embodiments, the device is coated with a bioabsorbable polymer that is capable of resorption in at least one of: about 1 day, about 3 days, about 5 days, about 7 days, about 14 days, about 3 weeks, about 4 weeks, about 45 days, about 60 days, about 90 days, about 180 days, about 6 months, about 9 months, about 1 year, about 1 to about 2 days, about 1 to about 5 days, about 1 to about 2 weeks, about 2 to about 4 weeks, about 45 to about 60 days, about 45 to about 90 days, about 30 to about 90 days, about 60 to about 90 days, about 90 to about 180 days, about 60 to about 180 days, about 180 to about 365 days, about 6 months to about 9 months, about 9 months to about 12 months, about 9 months to about 15 months, and about 1 year to about 2 years.

[0096] Examples of polymers that may be used in the present invention include, but are not limited to polycarboxy-

lic acids, cellulosic polymers, proteins, polypeptides, polyvinylpyrrolidone, maleic anhydride polymers, polyamides, polyvinyl alcohols, polyethylene oxides, glycosaminoglycans, polysaccharides, polyesters, aliphatic polyesters, polyurethanes, polystyrenes, copolymers, silicones, silicone containing polymers, polyalkyl siloxanes, polyorthoesters, polyanhydrides, copolymers of vinyl monomers, polycarbonates, polyethylenes, polypropylenes, polylactic acids, polylactides, polyglycolic acids, polyglycolides, polylactide-co-glycolides, polycaprolactones, poly(ϵ -caprolactone)s, polyhydroxybutyrate valerates, polyacrylamides, polyethers, polyurethane dispersions, polyacrylates, acrylic latex dispersions, polyacrylic acid, polyalkyl methacrylates, polyalkylene-co-vinyl acetates, polyalkylenes, aliphatic polycarbonates polyhydroxyalkanoates, polytetrahaloalkylenes, poly(phosphasones), polytetrahaloalkylenes, poly(phosphasones), and mixtures, combinations, and copolymers thereof.

[0097] The polymers of the present invention may be natural or synthetic in origin, including gelatin, chitosan, dextrin, cyclodextrin, Poly(urethanes), Poly(siloxanes) or silicones, Poly(acrylates) such as [rho]oly(methyl methacrylate), poly(butyl methacrylate), and Poly(2-hydroxy ethyl methacrylate), Poly(vinyl alcohol) Poly(olefins) such as poly(ethylene), [rho]oly(isoprene), halogenated polymers such as Poly(tetrafluoroethylene)- and derivatives and copolymers such as those commonly sold as Teflon(R) products, Poly(vinylidene fluoride), Poly(vinyl acetate), Poly(vinyl pyrrolidone), Poly(acrylic acid), Polyacrylamide, Poly(ethylene-co-vinyl acetate), Poly(ethylene glycol), Poly(propylene glycol), Poly(methacrylic acid); etc.

[0098] Suitable polymers also include absorbable and/or resorbable polymers including the following, combinations, copolymers and derivatives of the following: Polylactides (PLA), Polyglycolides (PGA), PolyLactide-co-glycolides (PLGA), Polyanhydrides, Polyorthoesters, Poly(N-(2-hydroxypropyl) methacrylamide), Poly(l-aspartamide), including the derivatives DLPLA—poly(dl-lactide); LPLA—poly(l-lactide); PDO—poly(dioxanone); PGA-TMC—poly(glycolide-co-trimethylene carbonate); PGA-LPLA—poly(l-lactide-co-glycolide); PGA-DLPLA—poly(dl-lactide-co-glycolide); LPLA—DLPLA—poly(l-lactide-co-dl-lactide); and PDO-PGA-TMC—poly(glycolide-co-trimethylene carbonate-co-dioxanone), and combinations thereof.

[0099] In some embodiments of the devices, coatings and/or methods provided herein the polymer comprises PLGA. In some embodiments of the methods, coatings, or devices provided herein, the PLGA comprises about 50:50 Lactic acid:Glycolic acid. The PLGA may have at least one of: a MW of about 30 KDa and a Mn of about 15 KDa, a Mn of about 10 KDa to about 25 KDa, and a MW of about 15 KDa to about 40 KDa. In some embodiments of the methods, coatings, or devices provided herein, the PLGA comprises 50:50 Lactic acid:Glycolic acid. In some embodiments of the methods, coatings, or devices provided herein, the PLGA comprises from 40:60 to 60:40 Lactic acid:Glycolic acid. In some embodiments of the methods, coatings, or devices provided herein, the PLGA comprises from 45:55 to 55:45 Lactic acid:Glycolic acid. In some embodiments of the methods, coatings, or devices provided herein, the PLGA comprises from 48:52 to 52:48 Lactic acid:Glycolic acid. In some embodiments of the methods, coatings, or devices provided herein, the PLGA comprises from 49:51 to 51:49 Lactic acid:Glycolic acid. The use of the term “about” with regard to

the ratio of Lactic acid to Glycolic acid in the PLGA, as used herein, refers to ranges of ratios from 40:60 to 60:40, or from 45:55 to 55:45, or from 48:52 to 52:48 or from 49:51 to 51:49, depending on the embodiment.

[0100] “Copolymer” as used herein refers to a polymer being composed of two or more different monomers. A copolymer may also and/or alternatively refer to random, block, graft, copolymers known to those of skill in the art.

[0101] “Biocompatible” as used herein, refers to any material that does not cause injury or death to the animal or induce an adverse reaction in an animal when placed in intimate contact with the animal’s tissues. Adverse reactions include for example inflammation, infection, fibrotic tissue formation, cell death, or thrombosis. The terms “biocompatible” and “biocompatibility” when used herein are art-recognized and mean that the referent is neither itself toxic to a host (e.g., an animal or human), nor degrades (if it degrades) at a rate that produces byproducts (e.g., monomeric or oligomeric subunits or other byproducts) at toxic concentrations, causes inflammation or irritation, or induces an immune reaction in the host. It is not necessary that any subject composition have a purity of 100% to be deemed biocompatible. Hence, a subject composition may comprise 99%, 98%, 97%, 96%, 95%, 90% 85%, 80%, 75% or even less of biocompatible agents, e.g., including polymers and other materials and excipients described herein, and still be biocompatible. “Non-biocompatible” as used herein, refers to any material that may cause injury or death to the animal or induce an adverse reaction in the animal when placed in intimate contact with the animal’s tissues. Such adverse reactions are as noted above, for example.

[0102] The terms “bioabsorbable,” “biodegradable,” “bioerodible,” “bioresorbable,” and “resorbable” are art-recognized synonyms. These terms are used herein interchangeably. Bioabsorbable polymers typically differ from non-bioabsorbable polymers in that the former may be absorbed (e.g.; degraded) during use. In certain embodiments, such use involves in vivo use, such as in vivo therapy, and in other certain embodiments, such use involves in vitro use. In general, degradation attributable to biodegradability involves the degradation of a bioabsorbable polymer into its component subunits, or digestion, e.g., by a biochemical process, of the polymer into smaller, non-polymeric subunits. In certain embodiments, biodegradation may occur by enzymatic mediation, degradation in the presence of water (hydrolysis) and/or other chemical species in the body, or both. The bioabsorbability of a polymer may be indicated in-vitro as described herein or by methods known to one of skill in the art. An in-vitro test for bioabsorbability of a polymer does not require living cells or other biologic materials to indicate bioabsorption properties (e.g. degradation, digestion). Thus, resorbition, resorption, absorption, absorption, erosion may also be used synonymously with the terms “bioabsorbable,” “biodegradable,” “bioerodible,” and “bioresorbable.” Mechanisms of degradation of a bioabsorbable polymer may include, but are not limited to, bulk degradation, surface erosion, and combinations thereof.

[0103] As used herein, the term “biodegradation” encompasses both general types of biodegradation. The degradation rate of a biodegradable polymer often depends in part on a variety of factors, including the chemical identity of the linkage responsible for any degradation, the molecular weight, crystallinity, biostability, and degree of cross-linking of such polymer, the physical characteristics (e.g., shape and size) of

the implant, and the mode and location of administration. For example, the greater the molecular weight, the higher the degree of crystallinity, and/or the greater the biostability, the biodegradation of any bioabsorbable polymer is usually slower.

[0104] “Degradation” as used herein refers to the conversion or reduction of a chemical compound to one less complex, e.g., by splitting off one or more groups of atoms. Degradation of the coating may reduce the coating’s cohesive and adhesive binding to the device, thereby facilitating transfer of the coating to the intervention site.

[0105] “Therapeutically desirable morphology” as used herein refers to the gross form and structure of the pharmaceutical agent, once deposited on the substrate, so as to provide for optimal conditions of ex vivo storage, in vivo preservation and/or in vivo release. Such optimal conditions may include, but are not limited to, the nature of the pharmaceutical agent, the disease to be treated/prevented, the intended storage conditions for the substrate prior to use or the location within the body of any biomedical implant. Preferably at least 10%, 20%, 30%, 40%, 50%, 60%, 70%, 80%, 90%, 95%, 97%, 98%, 99%, 99.5%, and/or 100% of the pharmaceutical agent is in crystalline or semi-crystalline form.

[0106] In some embodiments of the methods and/or devices provided herein, the macrolide immunosuppressive drug is at least 50% crystalline. In some embodiments, the macrolide immunosuppressive drug is at least 75% crystalline. In some embodiments, the macrolide immunosuppressive drug is at least 90% crystalline. In some embodiments of the methods and/or devices provided herein the macrolide immunosuppressive drug is at least 95% crystalline. In some embodiments of the methods and/or devices provided herein the macrolide immunosuppressive drug is at least 97% crystalline. In some embodiments of the methods and/or devices provided herein the macrolide immunosuppressive drug is at least 98% crystalline. In some embodiments of the methods and/or devices provided herein the macrolide immunosuppressive drug is at least 99% crystalline.

[0107] In some embodiments of the methods and/or devices provided herein wherein the pharmaceutical agent is at least 50% crystalline. In some embodiments of the methods and/or devices provided herein the pharmaceutical agent is at least 75% crystalline. In some embodiments of the methods and/or devices provided herein the pharmaceutical agent is at least 90% crystalline. In some embodiments of the methods and/or devices provided herein the pharmaceutical agent is at least 95% crystalline. In some embodiments of the methods and/or devices provided herein the pharmaceutical agent is at least 97% crystalline. In some embodiments of the methods and/or devices provided herein pharmaceutical agent is at least 98% crystalline. In some embodiments of the methods and/or devices provided herein the pharmaceutical agent is at least 99% crystalline.

[0108] “Stabilizing agent” as used herein refers to any substance that maintains or enhances the stability of the biological agent. Ideally these stabilizing agents are classified as Generally Regarded As Safe (GRAS) materials by the US

Food and Drug Administration (FDA). Examples of stabilizing agents include, but are not limited to carrier proteins, such as albumin, gelatin, metals or inorganic salts. Pharmaceutically acceptable excipient that may be present can further be found in the relevant literature, for example in the Handbook of Pharmaceutical Additives: An International Guide to More Than 6000 Products by Trade Name, Chemical, Function, and Manufacturer; Michael and Irene Ash (Eds.); Gower Publishing Ltd.; Aldershot, Hampshire, England, 1995.

[0109] “Intervention site” as used herein refers to the location in the body where the coating is intended to be delivered (by transfer from, freeing from, and/or dissociating from the substrate). The intervention site can be any substance in the medium surrounding the device, e.g., tissue, cartilage, a body fluid, etc. The intervention site can be the same as the treatment site, i.e., the substance to which the coating is delivered is the same tissue that requires treatment. Alternatively, the intervention site can be separate from the treatment site, requiring subsequent diffusion or transport of the pharmaceutical or other agent away from the intervention site.

[0110] “Compressed fluid” as used herein refers to a fluid of appreciable density (e.g., >0.2 g/cc) that is a gas at standard temperature and pressure. “Supercritical fluid,” “near-critical fluid,” “near-supercritical fluid,” “critical fluid,” “densified fluid,” or “densified gas,” as used herein refers to a compressed fluid under conditions wherein the temperature is at least 80% of the critical temperature of the fluid and the pressure is at least 50% of the critical pressure of the fluid, and/or a density of +50% of the critical density of the fluid.

[0111] Examples of substances that demonstrate supercritical or near critical behavior suitable for the present invention include, but are not limited to carbon dioxide, isobutylene, ammonia, water, methanol, ethanol, ethane, propane, butane, pentane, dimethyl ether, xenon, sulfur hexafluoride, halogenated and partially halogenated materials such as chlorofluorocarbons, hydrochlorofluorocarbons, hydrofluorocarbons, perfluorocarbons (such as perfluoromethane and perfluoropropane, chloroform, trichloro-fluoromethane, dichloro-difluoromethane, dichloro-tetrafluoroethane) and mixtures thereof. Preferably, the supercritical fluid is hexafluoropropane (FC-236EA), or 1,1,1,2,3,3-hexafluoropropane. Preferably, the supercritical fluid is hexafluoropropane (FC-236EA), or 1,1,1,2,3,3-hexafluoropropane for use in PLGA polymer coatings.

[0112] “Sintering” as used herein refers to the process by which parts of the polymer or the entire polymer becomes continuous (e.g., formation of a continuous polymer film). As discussed herein, the sintering process is controlled to produce a fully conformal continuous polymer (complete sintering) or to produce regions or domains of continuous coating while producing voids (discontinuities) in the polymer. As well, the sintering process is controlled such that some phase separation is obtained or maintained between polymer different polymers (e.g., polymers A and B) and/or to produce phase separation between discrete polymer particles. Through the sintering process, the adhesions properties of the coating are improved to reduce flaking of detachment of the coating from the substrate during manipulation in use. As described herein, in some embodiments, the sintering process is controlled to provide incomplete sintering of the polymer. In embodiments involving incomplete sintering, a polymer is formed with continuous domains, and voids, gaps, cavities, pores, channels or, interstices that provide space for sequestering a therapeutic agent which is released under controlled

conditions. Depending on the nature of the polymer, the size of polymer particles and/or other polymer properties, a compressed gas, a densified gas, a near critical fluid or a supercritical fluid may be employed. In one example, carbon dioxide is used to treat a substrate that has been coated with a polymer and a drug, using dry powder and RESS electrostatic coating processes. In another example, isobutylene is employed in the sintering process. In other examples a mixture of carbon dioxide and isobutylene is employed. In another example, 1,1,2,3,3-hexafluoropropane is employed in the sintering process.

[0113] When an amorphous material is heated to a temperature above its glass transition temperature, or when a crystalline material is heated to a temperature above a phase transition temperature, the molecules comprising the material are more mobile, which in turn means that they are more active and thus more prone to reactions such as oxidation. However, when an amorphous material is maintained at a temperature below its glass transition temperature, its molecules are substantially immobilized and thus less prone to reactions. Likewise, when a crystalline material is maintained at a temperature below its phase transition temperature, its molecules are substantially immobilized and thus less prone to reactions. Accordingly, processing drug components at mild conditions, such as the deposition and sintering conditions described herein, minimizes cross-reactions and degradation of the drug component. One type of reaction that is minimized by the processes of the invention relates to the ability to avoid conventional solvents which in turn minimizes-oxidation of drug, whether in amorphous, semi-crystalline, or crystalline form, by reducing exposure thereof to free radicals, residual solvents, protic materials, polar-protic materials, oxidation initiators, and autoxidation initiators.

[0114] "Rapid Expansion of Supercritical Solutions" or "RESS" as used herein involves the dissolution of a polymer into a compressed fluid, typically a supercritical fluid, followed by rapid expansion into a chamber at lower pressure, typically near atmospheric conditions. The rapid expansion of the supercritical fluid solution through a small opening, with its accompanying decrease in density, reduces the dissolution capacity of the fluid and results in the nucleation and growth of polymer particles. The atmosphere of the chamber is maintained in an electrically neutral state by maintaining an isolating "cloud" of gas in the chamber. Carbon dioxide, nitrogen, argon, helium, or other appropriate gas is employed to prevent electrical charge is transferred from the substrate to the surrounding environment.

[0115] "Electrostatic Rapid Expansion of Supercritical Solutions" or "e-RESS" or "eRESS" as used herein refers to Electrostatic Capture as described herein combined with Rapid Expansion of Supercritical Solutions as described herein. In some embodiments, Electrostatic Rapid Expansion of Supercritical Solutions refers to Electrostatic capture as described in the art, e.g., in U.S. Pat. No. 6,756,084, "Electrostatic deposition of particles generated from rapid expansion of supercritical fluid solutions," incorporated herein by reference in its entirety.

[0116] Electrostatic Capture may be used for depositing a coating on a device (e.g. a balloon), and may be referred to as "eSTAT" herein. Coating is applied to the balloons via eSTAT attraction, where the positively charged coating coat a negatively charged device. For example, in some embodiments, sirolimus in crystalline form is applied to the balloons via eSTAT attraction where the positively charged drug particles

coat the negatively charged balloons. The sirolimus coated on the balloon, in some embodiments, has an inherently positive charge.

[0117] FIG. 2 depicts an example eSTAT process for coating 12 angioplasty balloons with sirolimus. In this example process, an eight liter aluminum foil coated bell jar 2 is kept in place, but is not electrically grounded. Milled sirolimus (15.5 mg) is placed in a Swagelok 1/2" tee filter 18 (Swagelok, Inc., Supplemental Figure S15) connected to a pulsed pneumatic valve 20 (Swagelok, Inc., Supplemental Figure S16) attached to a cylinder of compressed nitrogen 22. The tee filter is connected on the other end to the eSTAT nozzle 14, a 1/2"x3/8" Swagelok reducing union fitted to a modified 3/8" Swagelok bulkhead union (Swagelok, Inc., Supplemental Figure S17) via 1/2" (outer diameter) polypropylene tubing 16. Balloon(s) 4 are mounted in place under the bell jar 2. In this example, twelve 3.0 mm width balloons at a time are coated with the positively charged milled sirolimus 6. The balloons 4 may be of various lengths, such as lengths ranging from 17 mm to 23 mm, however, in other embodiments, other sizes may be used. In some embodiments, fewer or more balloons may be coated at a time. The balloons 4 used during the coating process are typically mounted on catheters having wires 10 disposed therein 8 which are coupled to a high voltage power supply 12 (such as a Spellman SL30 high voltage power supply), which may be set at -15 kV, for example.

[0118] In some embodiments, the lengths of the balloons may be any length from 5 mm to 35 mm, or any of the following lengths, for example: about 5 mm, about 7 mm, about 8 mm, about 10 mm, about 12 mm, about 13 mm, about 15 mm, about 18 mm, about 20 mm, about 21 mm, about 23 mm, about 25 mm, about 28 mm, about 30 mm, about 32 mm, about 33 mm, and about 35 mm. The term "about" when used in the context of balloon length, can mean variations of for example, 10%, 25%, 50%, 0.1 mm, 0.25 mm, 0.5 mm, 1 mm, 2 mm, and 5 mm, depending on the embodiment.

[0119] In some embodiments, the diameters (i.e. widths) of the balloons may be any diameter from 1.5 mm to 6.0 mm, or any of the following diameters, for example: about 1.5 mm, about 1.8 mm, about 2.0 mm, about 2.25 mm, about 2.5 mm, about 2.75 mm, about 3.0 mm, about 3.25 mm, about 3.5 mm, about 3.75 mm, about 4.0 mm, about 4.25 mm, about 4.5 mm, about 4.75 mm, about 5.0 mm, about 5.25 mm, and about 5.5 mm. The term "about" when used in the context of balloon diameter (or width), can mean variations of for example, 10%, 25%, 50%, 0.1 mm, 0.25 mm, 0.3 mm, 0.4 mm, 0.5 mm, 0.75 mm, 1 mm, and 2 mm, depending on the embodiment.

[0120] In some embodiments a minimum of one balloon is coated at a time. In some embodiments, at least one of: at least 3 balloons, at least 5 balloons, at least 6 balloons, at least 8 balloons, at least 10 balloons, at least 12 balloons, at least 15 balloons, at least 16 balloons, at least 20 balloons, at least 24 balloons, and at least 30 balloons are coated at a time.

[0121] These balloons may or may not be pre-coated with a polymer, such as PLGA. Coating of the balloons may be achieved by various means, such as dip coating, spray coating, or coating using an RESS method. For example, a polymer (e.g. PLGA) is applied to the balloons via rapid expansion of supercritical solutions (RESS), where the solute (e.g. PLGA) is dissolved in a supercritical fluid then rapidly expanded with sudden decompression by passing through a short nozzle into an area of low temperature and pressure. These conditions cause the dissolved PLGA to rapidly pre-

cipitate as a fine powder with a narrow distribution of particle size resulting in a uniform coating on the angioplasty balloons.

[0122] FIG. 3 depicts an example RESS process for coating balloons 4 with PLGA. The PLGA is loaded into a vessel 24 in which it is dissolved in HFC236 ea from a HFC236ea cylinder 26 which is sent to the vessel 24 through a syringe pump 28 (for example, an Isco 260D syringe pump). The PLGA thus forms a supercritical solution with the HFC236 ea, which is stirred at a high pressure (5500 psi) in mixing view cells (50 cc). The PLGA solution is sent through a syringe pump 30 (for example, an Isco 260D syringe pump) which sends the solution through a heater block 32 (with temperature control feedback) and then through a timed pneumatic valve 34 which is heated at 137 C. The PLGA solution is then sent through a capillary tube 36 (e.g. PEEKs1 capillary tube 1/16" outer diameter by 100 micron inner diameter by 10 cm long) which is surrounded by a stainless steel sheath (e.g. 1/4 inches thick stainless steel sheath). The PLGA is then ejected through a nozzle 40 which is electrically grounded (for example, via a stainless steel sheath). When the PLGA solution exits the nozzle 40, the PLGA is ejected as dry PLGA particles 42, as the solution comprising PLGA and HFC236ea rapidly expands. The balloons 4 used during the coating process are typically mounted on catheters having wires 10 disposed therein 8 which are electrically grounded 44. The wires 10 may be coupled to a high voltage power supply 12 (such as a Spellman SL30 high voltage power supply), in order to facilitate the eSTAT coating of the balloons with the active agent, however, during the RESS process described in this embodiment, the balloons are electrically grounded and no current flows from the power supply 12.

[0123] When viewed in combination, FIGS. 2 and 3 indicate a single apparatus that can both coat according to an RESS process and an eSTAT process. Elements called out and depicted in FIG. 2 may similarly be called out in FIG. 3, and vice versa. Alternatively, separate coating apparatuses may be used to separately coat according to an RESS process and an eSTAT process.

[0124] "Solution Enhanced Dispersion of Supercritical Solutions" or "SEDS" as used herein involves a spray process for the generation of polymer particles, which are formed when a compressed fluid (e.g. supercritical fluid, preferably supercritical CO₂) is used as a diluent to a vehicle in which a polymer is dissolved (one that can dissolve both the polymer and the compressed fluid). The mixing of the compressed fluid diluent with the polymer-containing solution may be achieved by encounter of a first stream containing the polymer solution and a second stream containing the diluent compressed fluid, for example, within one spray nozzle or by the use of multiple spray nozzles. The solvent in the polymer solution may be one compound or a mixture of two or more ingredients and may be or comprise an alcohol (including diols, triols, etc.), ether, amine, ketone, carbonate, or alkanes, or hydrocarbon (aliphatic or aromatic) or may be a mixture of compounds, such as mixtures of alkanes, or mixtures of one or more alkanes in combination with additional compounds such as one or more alcohols, (e.g., from 0 or 0.1 to 5% of a C₁ to C₁₅ alcohol, including diols, triols, etc.). See for example U.S. Pat. No. 6,669,785, incorporated herein by reference in its entirety. The solvent may optionally contain a surfactant, as also described in, e.g., U.S. Pat. No. 6,669,785.

[0125] In one embodiment of the SEDS process, a first stream of fluid comprising a polymer dissolved in a common solvent is co-sprayed with a second stream of compressed fluid. Polymer particles are produced as the second stream acts as a diluent that weakens the solvent in the polymer solution of the first stream. The now combined streams of fluid, along with the polymer particles, flow out of the nozzle assembly into a collection vessel. Control of particle size, particle size distribution, and morphology is achieved by tailoring the following process variables: temperature, pressure, solvent composition of the first stream, flow-rate of the first stream, flow-rate of the second stream, composition of the second stream (where soluble additives may be added to the compressed gas), and conditions of the capture vessel. Typically the capture vessel contains a fluid phase that is at least five to ten times (5-10x) atmospheric pressure.

[0126] "Electrostatic Dry Powder Coating" or "e-DPC" or "eDPC" as used herein refers to Electrostatic Capture as described herein combined with Dry Powder Coating. e-DPC deposits material (including, for example, polymer or impermeable dispersed solid) on the device or other substrate as dry powder, using electrostatic capture to attract the powder particles to the substrate. Dry powder spraying ("Dry Powder Coating" or "DPC") is well known in the art, and dry powder spraying coupled with electrostatic capture has been described, for example in U.S. Pat. Nos. 5,470,603, 6,319,541, and 6,372,246, all incorporated herein by reference in their entirety. Methods for depositing coatings are described, e.g., in WO 2008/148013, "Polymer Films for Medical Device Coating," incorporated herein by reference in its entirety.

[0127] "Dipping Process" and "Spraying Process" as used herein refer to methods of coating substrates that have been described at length in the art. These processes can be used for coating medical devices with pharmaceutical agents. Spray coating, described in, e.g., U.S. Pat. No. 7,419,696, "Medical devices for delivering a therapeutic agent and method of preparation" and elsewhere herein, can involve spraying or airbrushing a thin layer of solubilized coating or dry powder coating onto a substrate. Dip coating involves, e.g., dipping a substrate in a liquid, and then removing and drying it. Dip coating is described in, e.g., U.S. Pat. No. 5,837,313 "Drug release stent coating process," incorporated herein by reference in its entirety.

[0128] "Bulk properties" properties of a coating including a pharmaceutical or a biological agent that can be enhanced through the methods of the invention include for example: adhesion, smoothness, conformality, thickness, and compositional mixing.

[0129] "Electrostatically charged" or "electrical potential" or "electrostatic capture" as used herein refers to the collection of the spray-produced particles upon a substrate that has a different electrostatic potential than the sprayed particles. Thus, the substrate is at an attractive electronic potential with respect to the particles exiting, which results in the capture of the particles upon the substrate. i.e. the substrate and particles are oppositely charged, and the particles transport through the gaseous medium of the capture vessel onto the surface of the substrate is enhanced via electrostatic attraction. This may be achieved by charging the particles and grounding the substrate or conversely charging the substrate and grounding the particles, by charging the particles at one potential (e.g. negative charge) and charging the substrate at an opposite poten-

tial (e.g. positive charge), or by some other process, which would be easily envisaged by one of skill in the art of electrostatic capture.

[0130] “Depositing the active agent by an e-RESS, an e-SEDS, or an e-DPC process without electrically charging the substrate” as used herein refers to any of these processes as performed without intentionally electrically charging the substrate. It is understood that the substrate might become electrically charged unintentionally during any of these processes.

[0131] “Depositing the active agent by an e-RESS, an e-SEDS, or an e-DPC process without creating an electrical potential between the substrate and a coating apparatus” as used herein refers to any of these processes as performed without intentionally generating an electrical potential between the substrate and the coating apparatus. It is understood that electrical potential between the substrate and the coating apparatus might be generated unintentionally during any of these processes.

[0132] “Intimate mixture” as used herein, refers to two or more materials, compounds, or substances that are uniformly distributed or dispersed together.

[0133] “Layer” as used herein refers to a material covering a surface or forming an overlying part or segment. Two different layers may have overlapping portions whereby material from one layer may be in contact with material from another layer. Contact between materials of different layers can be measured by determining a distance between the materials. For example, Raman spectroscopy may be employed in identifying materials from two layers present in close proximity to each other.

[0134] While layers defined by uniform thickness and/or regular shape are contemplated herein, several embodiments described herein relate to layers having varying thickness and/or irregular shape. Material of one layer may extend into the space largely occupied by material of another layer. For example, in a coating having three layers formed in sequence as a first polymer layer, a pharmaceutical agent layer and a second polymer layer, material from the second polymer layer which is deposited last in this sequence may extend into the space largely occupied by material of the pharmaceutical agent layer whereby material from the second polymer layer may have contact with material from the pharmaceutical layer. It is also contemplated that material from the second polymer layer may extend through the entire layer largely occupied by pharmaceutical agent and contact material from the first polymer layer.

[0135] It should be noted however that contact between material from the second polymer layer (or the first polymer layer) and material from the pharmaceutical agent layer (e.g.; a pharmaceutical agent crystal particle or a portion thereof) does not necessarily imply formation of a mixture between the material from the first or second polymer layers and material from the pharmaceutical agent layer. In some embodiments, a layer may be defined by the physical three-dimensional space occupied by crystalline particles of a pharmaceutical agent (and/or biological agent). It is contemplated that such layer may or may not be continuous as physical space occupied by the crystal particles of pharmaceutical agents may be interrupted, for example, by polymer material from an adjacent polymer layer. An adjacent polymer layer may be a layer that is in physical proximity to be pharmaceutical agent particles in the pharmaceutical agent layer. Similarly, an adjacent layer may be the layer formed in a process

step right before or right after the process step in which pharmaceutical agent particles are deposited to form the pharmaceutical agent layer.

[0136] As described herein, material deposition and layer formation provided herein are advantageous in that the pharmaceutical agent remains largely in crystalline form during the entire process. While the polymer particles and the pharmaceutical agent particles may be in contact, the layer formation process is controlled to avoid formation of a mixture between the pharmaceutical agent particles the polymer particles during formation of a coated device.

[0137] In some embodiments, the coating comprises a plurality of layers deposited on the substrate, wherein at least one of the layers comprises the active agent. In some embodiments, at least one of the layers comprises a polymer. In some embodiments, the polymer is bioabsorbable. In some embodiments, the active agent and the polymer are in the same layer, in separate layers, or form overlapping layers. In some embodiments, the plurality of layers comprise five layers deposited as follows: a first polymer layer, a first active agent layer, a second polymer layer, a second active agent layer and a third polymer layer.

[0138] In some embodiments of the methods and/or devices provided herein, the coating comprises a plurality of layers deposited on the substrate, wherein at least one of the layers comprises the active agent. In some embodiments, at least one of the layers comprises a polymer. In some embodiments, the polymer is bioabsorbable. In some embodiments, the active agent and the polymer are in the same layer, in separate layers, or form overlapping layers. In some embodiments, the coating comprises a plurality of layers deposited on the substrate, wherein at least one of the layers comprises the pharmaceutical agent. In some embodiments, the pharmaceutical agent and the polymer are in the same layer, in separate layers, or form overlapping layers. In some embodiments, the plurality of layers comprise five layers deposited as follows: a first polymer layer, a first active agent layer, a second polymer layer, a second active agent layer and a third polymer layer. In some embodiments, the plurality of layers comprise five layers deposited as follows: a first polymer layer, a first pharmaceutical agent layer, a second polymer layer, a second pharmaceutical agent layer and a third polymer layer. In some embodiments, the plurality of layers comprise five layers deposited as follows: a first polymer layer, a first active biological agent layer, a second polymer layer, a second active biological agent layer and a third polymer layer.

[0139] In some embodiments, the device provides the coating to the intervention site over an area of delivery greater than the outer surface contact area of the substrate. In some embodiments, the area of delivery is at least 110% greater than the outer surface contact area of the substrate. In some embodiments, the area of delivery is at least 110% to 200% greater than the outer surface contact area of the substrate. In some embodiments, the area of delivery is at least 200% greater than the outer surface contact area of the substrate.

[0140] “Laminate coating” as used herein refers to a coating made up of two or more layers of material. Means for creating a laminate coating as described herein (e.g.; a laminate coating comprising bioabsorbable polymer(s) and pharmaceutical agent) may include coating the stent with drug and polymer as described herein (e-RESS, e-DPC, compressed-gas sintering). The process comprises performing multiple and sequential coating steps (with sintering steps for polymer materials) wherein different materials may be deposited in

each step, thus creating a laminated structure with a multitude of layers (at least 2 layers) including polymer layers and pharmaceutical agent layers to build the final device (e.g.; laminate coated stent).

[0141] “Portion of the coating” and “portion of the active agent” as used herein refer to an amount or percentage of the coating or active agent that is freed, dissociated, and/or transferred from the substrate to the intervention site, either at a designated point in delivery, during a certain period of delivery, or in total throughout the entire delivery process. In embodiments, the device and methods of the invention are adapted to free, dissociate, and/or transfer a certain amount of the coating and/or active agent.

[0142] For example, in embodiments, at least about 10%, at least about 20%, at least about 30%, at least about 50%, at least about 75%, at least about 85%, at least about 90%, at least about 95%, and/or at least about 99% of the coating is adapted to be freed, dissociated, and/or to be transferred from the substrate to the intervention site. In embodiments, at least about 10%, at least about 20%, at least about 30%, at least about 50%, at least about 75%, at least about 85%, at least about 90%, at least about 95%, and/or at least about 99% of the active agent is adapted to be freed, dissociated, and/or to be transferred from the substrate to the intervention site.

[0143] The portion of the coating and/or that is freed, dissociated, or transferred from the device substrate is influenced by any or a combination of, e.g., the size, shape, and flexibility of the device substrate, the size, shape, surface qualities of and conditions (e.g., blood or lymph circulation, temperature, etc.) at the intervention site, the composition of the coating, including the particular active agent(s) and specific polymer component(s) used in the coating, the relative proportions of these components, the use of any release agent (s), and substrate characteristics. Any one or more of these and other aspects of the device and methods of the invention can be adapted to influence the portion of the coating and/or active agent freed, dissociated, and/or transferred, as desired to produce the desired clinical outcome.

[0144] “Substantially all of the coating” as used herein refers to at least about 50%, at least about 75%, at least about 85%, at least about 90%, at least about 95%, at least about 97%, and/or at least about 99% percent of the coating that was present on the device prior to use.

[0145] “At least a portion of the substrate” as used herein refers to an amount and/or percentage of the substrate. In embodiments of the device and methods of the invention wherein a coating is on “at least a portion of the substrate,” at least about 10%, at least about 20%, at least about 30%, at least about 50%, at least about 75%, at least about 85%, at least about 90%, at least about 95%, and/or at least about 99% of the substrate is coated. In embodiments wherein “at least a portion of the substrate” is bioabsorbable, at least about 10%, at least about 20%, at least about 30%, at least about 50%, at least about 75%, at least about 85%, at least about 90%, at least about 95%, and/or at least about 99% of the substrate is bioabsorbable.

[0146] “Transferring at least a portion” as used herein in the context of transferring a coating or active agent from the substrate to an intervention site refers to an amount and/or percentage of the coating or active agent that is transferred from the substrate to an intervention site. In embodiments of the device and methods of the invention wherein at least a portion of a coating or active agent is transferred from the substrate to an intervention site, at least about 10%, at least

about 20%, at least about 30%, at least about 50%, at least about 75%, at least about 85%, at least about 90%, at least about 95%, and/or at least about 99% of the coating or active agent is transferred from the substrate to the intervention site. In some embodiments, at least about 10%, at least about 20%, at least about 30%, at least about 50%, at least about 75%, at least about 85%, at least about 90%, at least about 95%, and/or at least about 99% of the coating is adapted to transfer from the substrate to the intervention site. In some embodiments, at least about 10% of the coating is adapted to transfer from the substrate to the intervention site. In some embodiments, at least about 20% of the coating is adapted to transfer from the substrate to the intervention site. In some embodiments, at least about 30% of the coating is adapted to transfer from the substrate to the intervention site. In some embodiments, at least about 50% of the coating is adapted to transfer from the substrate to the intervention site. In some embodiments, at least about 75% of the coating is adapted to transfer from the substrate to the intervention site. In some embodiments, at least about 85% of the coating is adapted to transfer from the substrate to the intervention site. In some embodiments, at least about 90% of the coating is adapted to transfer from the substrate to the intervention site. In some embodiments, at least about 95% of the coating is adapted to transfer from the substrate to the intervention site. In some embodiments, at least about 99% of the coating is adapted to transfer from the substrate to the intervention site. As used herein, “about” when used in reference to a percentage of the coating can mean ranges of 1%-5%, of 5%-10%, of 10%-20%, and/or of 10%-50% (as a percent of the percentage of the coating transferred, or as a variation of the percentage of the coating transferred).

[0147] In some embodiments, the coating portion that is adapted to transfer upon stimulation is on at least one of a distal surface of the substrate, a middle surface of the substrate, a proximal surface of the substrate, and an abluminal surface of the substrate. In some embodiments, the stimulation decreases the contact between the coating and the substrate. In some embodiments, device is adapted to transfer less than about 1%, less than about 5%, less than about 10%, less than about 15%, less than about 25%, less than about 50%, less than about 70%, less than about 80%, and/or less than about 90% of the coating absent stimulation of the coating.

[0148] In some embodiments, at least about 10%, at least about 20%, at least about 30%, at least about 50%, at least about 75%, at least about 85%, at least about 90%, at least about 95%, and/or at least about 99% of the active agent is adapted to transfer from the substrate to the intervention site. In some embodiments, at least about 10% of the active agent is adapted to transfer from the substrate to the intervention site. In some embodiments, at least about 20% of the active agent is adapted to transfer from the substrate to the intervention site. In some embodiments, at least about 30% of the active agent is adapted to transfer from the substrate to the intervention site. In some embodiments, at least about 50% of the active agent is adapted to transfer from the substrate to the intervention site. In some embodiments, at least about 75% of the active agent is adapted to transfer from the substrate to the intervention site. In some embodiments, at least about 85% of the active agent is adapted to transfer from the substrate to the intervention site. In some embodiments, at least about 90% of the active agent is adapted to transfer from the substrate to the intervention site. In some embodiments, at least about 95% of

the active agent is adapted to transfer from the substrate to the intervention site. In some embodiments, at least about 99% of the active agent is adapted to transfer from the substrate to the intervention site. As used herein, "about" when used in reference to a percentage of the active agent can mean ranges of 1%-5%, of 5%-10%, of 10%-20%, and/or of 10%-50% (as a percent of the percentage of the active agent transferred, or as a variation of the percentage of the active agent transferred).

[0149] In some embodiments, the active agent portion that is adapted to transfer upon stimulation is on at least one of a distal surface of the substrate, a middle surface of the substrate, a proximal surface of the substrate, and an abluminal surface of the substrate. In some embodiments, the stimulation decreases the contact between the coating and the substrate. In some embodiments, the device is adapted to transfer less than about 1%, less than about 5%, less than about 10%, less than about 15%, less than about 25%, less than about 50%, less than about 70%, less than about 80%, and/or less than about 90% of the active agent absent stimulation of the coating.

[0150] In some embodiments, the device is adapted to transfer at least about 10%, at least about 20%, at least about 30%, at least about 50%, at least about 75%, at least about 85%, at least about 90%, at least about 95%, and/or at least about 99% of the coating from the substrate to the intervention site. In some embodiments, the device is adapted to transfer at least about 10% of the coating from the substrate to the intervention site. In some embodiments, the device is adapted to transfer at least about 20% of the coating from the substrate to the intervention site. In some embodiments, the device is adapted to transfer at least about 30% of the coating from the substrate to the intervention site. In some embodiments, the device is adapted to transfer at least about 50% of the coating from the substrate to the intervention site. In some embodiments, the device is adapted to transfer at least about 75% of the coating from the substrate to the intervention site. In some embodiments, the device is adapted to transfer at least about 85% of the coating from the substrate to the intervention site. In some embodiments, the device is adapted to transfer at least about 90% of the coating from the substrate to the intervention site. In some embodiments, the device is adapted to transfer at least about 95% of the coating from the substrate to the intervention site. In some embodiments, the device is adapted to transfer at least about 99% of the coating from the substrate to the intervention site. As used herein, "about" when used in reference to a percentage of the coating can mean ranges of 1%-5%, of 5%-10%, of 10%-20%, and/or of 10%-50% (as a percent of the percentage of the coating transferred, or as a variation of the percentage of the coating transferred).

[0151] In some embodiments, the coating portion that transfers upon stimulation is on at least one of a distal surface of the substrate, a middle surface of the substrate, a proximal surface of the substrate, and an abluminal surface of the substrate. In some embodiments, stimulation decreases the contact between the coating and the substrate. In some embodiments, the device is adapted to transfer less than about 1%, less than about 5%, less than about 10%, less than about 15%, less than about 25%, less than about 50%, less than about 70%, less than about 80%, and/or less than about 90% of the coating absent stimulation of the coating.

[0152] In some embodiments, the device is adapted to transfer at least about 10%, at least about 20%, at least about 30%, at least about 50%, at least about 75%, at least about

85%, at least about 90%, at least about 95%, and/or at least about 99% of the active agent from the substrate to the intervention site. In some embodiments, the device is adapted to transfer at least about 10% of the active agent from the substrate to the intervention site. In some embodiments, the device is adapted to transfer at least about 20% of the active agent from the substrate to the intervention site. In some embodiments, the device is adapted to transfer at least about 30% of the active agent from the substrate to the intervention site. In some embodiments, the device is adapted to transfer at least about 50% of the active agent from the substrate to the intervention site. In some embodiments, the device is adapted to transfer at least about 75% of the active agent from the substrate to the intervention site. In some embodiments, the device is adapted to transfer at least about 85% of the active agent from the substrate to the intervention site. In some embodiments, the device is adapted to transfer at least about 90% of the active agent from the substrate to the intervention site. In some embodiments, the device is adapted to transfer at least about 95% of the active agent from the substrate to the intervention site. In some embodiments, the device is adapted to transfer at least about 99% of the active agent from the substrate to the intervention site. As used herein, "about" when used in reference to a percentage of the active agent can mean ranges of 1%-5%, of 5%-10%, of 10%-20%, and/or of 10%-50% (as a percent of the percentage of the active agent transferred, or as a variation of the percentage of the active agent transferred).

[0153] In some embodiments, the coating portion that transfers upon stimulation is on at least one of a distal surface of the substrate, a middle surface of the substrate, a proximal surface of the substrate, and an abluminal surface of the substrate. In some embodiments, the stimulation decreases the contact between the coating and the substrate. In some embodiments, the device is adapted to transfer less than about 1%, less than about 5%, less than about 10%, less than about 15%, less than about 25%, less than about 50%, less than about 70%, less than about 80%, less than about 90% of the active agent absent stimulation of the coating.

[0154] "Freeing at least a portion" as used herein in the context of freeing a coating and/or active agent from the substrate at an intervention site refers to an amount and/or percentage of a coating or active agent that is freed from the substrate at an intervention site. In embodiments of the device and methods of the invention wherein at least a portion of a coating or active agent is freed from the substrate at an intervention site, at least about 10%, at least about 20%, at least about 30%, at least about 50%, at least about 75%, at least about 85%, at least about 90%, at least about 95%, and/or at least about 99% of the coating or active agent is freed from the substrate at the intervention site. In some embodiments, the device is adapted to free at least about 10%, at least about 20%, at least about 30%, at least about 50%, at least about 75%, at least about 85%, at least about 90%, at least about 95%, and/or at least about 99% of the coating from the substrate. In some embodiments, the device is adapted to free at least about 10% of the coating from the substrate to the intervention site. In some embodiments, the device is adapted to free at least about 20% of the coating from the substrate to the intervention site. In some embodiments, the device is adapted to free at least about 30% of the coating from the substrate to the intervention site. In some embodiments, the device is adapted to free at least about 50% of the coating from the substrate to the intervention site. In some embodi-

ments, the device is adapted to free at least about 75% of the coating from the substrate to the intervention site. In some embodiments, the device is adapted to free at least about 85% of the coating from the substrate to the intervention site. In some embodiments, the device is adapted to free at least about 90% of the coating from the substrate to the intervention site. In some embodiments, the device is adapted to free at least about 95% of the coating from the substrate to the intervention site. In some embodiments, the device is adapted to free at least about 99% of the coating from the substrate to the intervention site. As used herein, "about" when used in reference to a percentage of the coating can mean ranges of 1%-5%, of 5%-10%, of 10%-20%, and/or of 10%-50% (as a percent of the percentage of the coating freed, or as a variation of the percentage of the coating freed).

[0155] In some embodiments, the coating portion that frees upon stimulation is on at least one of a distal surface of the substrate, a middle surface of the substrate, a proximal surface of the substrate, and an abluminal surface of the substrate.

[0156] In some embodiments, the stimulation decreases the contact between the coating and the substrate. In some embodiments, the device is adapted to free less than about 1%, less than about 5%, less than about 10%, less than about 15%, less than about 25%, less than about 50%, less than about 70%, less than about 80%, less than about 90% of the coating absent stimulation of the coating.

[0157] "Dissociating at least a portion" as used herein in the context of dissociating a coating and/or active agent from the substrate at an intervention site refers to an amount and/or percentage of a coating and/or active agent that is dissociated from the substrate at an intervention site. In embodiments of the device and methods of the invention wherein at least a portion of a coating and/or active agent is dissociated from the substrate at an intervention site, at least about 10%, at least about 20%, at least about 30%, at least about 50%, at least about 75%, at least about 85%, at least about 90%, at least about 95%, and/or at least about 99% of the coating and/or active agent is dissociated from the substrate at the intervention site.

[0158] In some embodiments, the device is adapted to dissociate at least about 10%, at least about 20%, at least about 30%, at least about 50%, at least about 75%, at least about 85%, at least about 90%, at least about 95%, and/or at least about 99% of the coating from the substrate. In some embodiments, the device is adapted to dissociate at least about 10% of the coating from the substrate to the intervention site. In some embodiments, the device is adapted to dissociate at least about 20% of the coating from the substrate to the intervention site. In some embodiments, the device is adapted to dissociate at least about 30% of the coating from the substrate to the intervention site. In some embodiments, the device is adapted to dissociate at least about 50% of the coating from the substrate to the intervention site. In some embodiments, the device is adapted to dissociate at least about 75% of the coating from the substrate to the intervention site. In some embodiments, the device is adapted to dissociate at least about 85% of the coating from the substrate to the intervention site. In some embodiments, the device is adapted to dissociate at least about 90% of the coating from the substrate to the intervention site. In some embodiments, the device is adapted to dissociate at least about 95% of the coating from the substrate to the intervention site. In some embodiments, the device is adapted to dissociate at least about 99% of the

coating from the substrate to the intervention site. As used herein, "about" when used in reference to a percentage of the coating can mean ranges of 1%-5%, of 5%-10%, of 10%-20%, and/or of 10%-50% (as a percent of the percentage of the coating dissociated, or as a variation of the percentage of the coating dissociated).

[0159] In some embodiments, the coating portion that dissociates upon stimulation is on at least one of a distal surface of the substrate, a middle surface of the substrate, a proximal surface of the substrate, and an abluminal surface of the substrate. In some embodiments, stimulation decreases the contact between the coating and the substrate. In some embodiments, the device is adapted to dissociate less than about 1%, less than about 5%, less than about 10%, less than about 15%, less than about 25%, less than about 50%, less than about 70%, less than about 80%, less than about 90% of the coating absent stimulation of the coating.

[0160] "Depositing at least a portion" as used herein in the context of a coating and/or active agent at an intervention site refers to an amount and/or percentage of a coating and/or active agent that is deposited at an intervention site. In embodiments of the device and methods of the invention wherein at least a portion of a coating and/or active agent is deposited at an intervention site, at least about 10%, at least about 20%, at least about 30%, at least about 50%, at least about 75%, at least about 85%, at least about 90%, at least about 95%, and/or at least about 99% of the coating and/or active agent is deposited at the intervention site. In some embodiments, stimulating decreases the contact between the coating and the substrate. In some embodiments, depositing deposits less than about 1%, less than about 5%, less than about 10%, less than about 15%, less than about 25%, less than about 50%, less than about 70%, less than about 80%, and/or less than about 90% of the coating absent stimulating at least one of the coating and the substrate.

[0161] "Delivering at least a portion" as used herein in the context of a coating and/or active agent at an intervention site refers to an amount and/or percentage of a coating and/or active agent that is delivered to an intervention site. In embodiments of the device and methods of the invention wherein at least a portion of a coating and/or active agent is delivered to an intervention site, at least about 10%, at least about 20%, at least about 30%, at least about 50%, at least about 75%, at least about 85%, at least about 90%, at least about 95%, and/or at least about 99% of the coating and/or active agent is delivered to the intervention site.

[0162] In some embodiments, the device is adapted to deliver at least about 10%, at least about 20%, at least about 30%, at least about 50%, at least about 75%, at least about 85%, at least about 90%, at least about 95%, and/or at least about 99% of the coating to the intervention site. In some embodiments, the device is adapted to deliver at least about 10% of the coating to the intervention site.

[0163] In some embodiments, the device is adapted to deliver at least about 20% of the coating to the intervention site. In some embodiments, the device is adapted to deliver at least about 30% of the coating to the intervention site. In some embodiments, the device is adapted to deliver at least about 50% of the coating to the intervention site. In some embodiments, the device is adapted to deliver at least about 75% of the coating to the intervention site. In some embodiments, the device is adapted to deliver at least about 85% of the coating to the intervention site. In some embodiments, the device is adapted to deliver at least about 90% of the coating to the

intervention site. In some embodiments, the device is adapted to deliver at least about 95% of the coating to the intervention site. In some embodiments, the device is adapted to deliver at least about 99% of the coating to the intervention site. As used herein, "about" when used in reference to a percentage of the coating can mean ranges of 1%-5%, of 5%-10%, of 10%-20%, and/or of 10%-50% (as a percent of the percentage of the coating delivered, or as a variation of the percentage of the coating delivered).

[0164] In some embodiments, the coating portion that is delivered upon stimulation is on at least one of a distal surface of the substrate, a middle surface of the substrate, a proximal surface of the substrate, and an abluminal surface of the substrate. In some embodiments, the stimulation decreases the contact between the coating and the substrate. In some embodiments, the device is adapted to deliver less than about 1%, less than about 5%, less than about 10%, less than about 15%, less than about 25%, less than about 50%, less than about 70%, less than about 80%, less than about 90% of the coating absent stimulation of the coating.

[0165] In some embodiments, depositing at least a portion of the coating comprises depositing at least about 10%, at least about 20%, at least about 30%, at least about 50%, at least about 75%, at least about 85%, at least about 90%, at least about 95%, and/or at least about 99% of the coating at the intervention site. In some embodiments, stimulating decreases the contact between the coating and the substrate. In some embodiments, depositing deposits less than about 1%, less than about 5%, less than about 10%, less than about 15%, less than about 25%, less than about 50%, less than about 70%, less than about 80%, and/or less than about 90% of the coating absent stimulating at least one of the coating and the substrate.

[0166] "Tacking at least a portion" as used herein in the context of tacking at least a portion of the coating to an intervention site refers to an amount and/or percentage of a coating and/or active agent that is tacked at an intervention site. In embodiments of the device and methods of the invention wherein at least a portion of a coating and/or active agent is tacked at an intervention site, at least about 10%, at least about 20%, at least about 30%, at least about 50%, at least about 75%, at least about 85%, at least about 90%, at least about 95%, and/or at least about 99% of the coating and/or active agent is tacked at the intervention site. In some embodiments, stimulating decreases the contact between the coating and the substrate. In some embodiments, tacking tacks less than about 1%, less than about 5%, less than about 10%, less than about 15%, less than about 25%, less than about 50%, less than about 70%, less than about 80%, and/or less than about 90% of the coating absent stimulating at least one of the coating and the substrate. In some embodiments, the device comprises a tacking element that cooperates with the stimulation to tack the coating to the intervention site. In some embodiments, the device comprises a tacking element that tacks the coating to the substrate until stimulating with a stimulation.

[0167] "Adhere," "adherence," "adhered," "cohere," "coherence," "cohered," and related terms, as used herein in the context of adherence or coherence of the substrate to the coating refer to an interaction between the substrate and the coating that is sufficiently strong to maintain the association of the coating with the substrate for an amount of time prior to the stimulation, e.g., mechanical, chemical, thermal, electromagnetic, or sonic stimulation, that is intended to cause the

coating to be freed, dissociated, and/or transferred. These same terms, as used in the context of an interaction between the coating and the target tissue area and/or intervention site refer to an interaction between the coating and the target tissue area and/or intervention site that is sufficient to keep the coating associated with the target tissue area and/or intervention site for an amount of time as desired for treatment, e.g., at least about 12 hours, about 1 day, about 3 days, about 5 days, about 7 days, about 14 days, about 3 weeks, about 4 weeks, about 45 days, about 60 days, about 90 days, about 180 days, about 6 months, about 9 months, about 1 year, about 1 to about 2 days, about 1 to about 5 days, about 1 to about 2 weeks, about 2 to about 4 weeks, about 45 to about 60 days, about 45 to about 90 days, about 30 to about 90 days, about 60 to about 90 days, about 90 to about 180 days, about 60 to about 180 days, about 180 to about 365 days, about 6 months to about 9 months, about 9 months to about 12 months, about 9 months to about 15 months, and about 1 year to about 2 years.

[0168] "Balloon" as used herein refers to a flexible sac that can be inflated within a natural or non-natural body lumen or cavity, or used to create a cavity, or used to enlarge an existing cavity. The balloon can be used transiently to dilate a lumen or cavity and thereafter may be deflated and/or removed from the subject during the medical procedure or thereafter. In embodiments, the balloon can be expanded within the body and has a coating thereon that is freed (at least in part) from the balloon and left behind in the lumen or cavity when the balloon is removed. A coating can be applied to a balloon either after the balloon has been compacted for insertion, resulting in a coating that partially covers the surface of the balloon, or it can be applied prior to or during compaction. In embodiments, a coating is applied to the balloon both prior to and after compaction of the balloon. In embodiments, the balloon is compacted by, e.g., crimping or folding. Methods of compacting balloons have been described, e.g., in U.S. Pat. No. 7,308,748, "Method for compressing an intraluminal device," and U.S. Pat. No. 7,152,452, "Assembly for crimping an intraluminal device and method of use," relating to uniformly crimping a balloon onto a catheter or other intraluminal device, and 5,350,361 "Tri-fold balloon for dilatation catheter and related method," relating to balloon folding methods and devices, all incorporated herein by reference in their entirety. In some embodiments the balloon is delivered to the intervention site by a delivery device. In some embodiments, the delivery device comprises catheter. In some embodiments, the balloon is an angioplasty balloon. Balloons can be delivered, removed, and visualized during delivery and removal by methods known in the art, e.g., for inserting angioplasty balloons, stents, and other medical devices. Methods for visualizing a treatment area and planning instrument insertion are described, e.g., in U.S. Pat. No. 7,171,255, "Virtual reality 3D visualization for surgical procedures" and U.S. Pat. No. 6,610,013, "3D ultrasound-guided intraoperative prostate brachytherapy," incorporated herein by reference in their entirety.

[0169] "Compliant balloon" as used herein refers to a balloon which conforms to the intervention site relatively more than a semi-compliant balloon and still more so than a non-compliant balloon. Compliant balloons expand and stretch with increasing pressure within the balloon, and are made from such materials as polyethylene or polyolefin copolymers. There is in the art a general classification of balloons based on their expandability or "compliance" relative to each

other, as described e.g., in U.S. Pat. No. 5,556,383, "Block copolymer elastomer catheter balloons." Generally, "non-compliant" balloons are the least elastic, increasing in diameter about 2-7%, typically about 5%, as the balloon is pressurized from an inflation pressure of about 6 atm to a pressure of about 12 atm, that is, they have a "distension" over that pressure range of about 5%. "Semi-compliant" balloons have somewhat greater distensions, generally 7-16% and typically 10-12% over the same pressurization range. "Compliant" balloons are still more distensible, having distensions generally in the range of 16-40% and typically about 21% over the same pressure range. Maximum distensions, i.e. distension from nominal diameter to burst, of various balloon materials may be significantly higher than the distension percentages discussed above because wall strengths, and thus burst pressures, vary widely between balloon materials. These distension ranges are intended to provide general guidance, as one of skill in the art will be aware that the compliance of a balloon is dependent on the dimensions and/or characteristics of the cavity and/or lumen walls, not only the expandability of the balloon.

[0170] A compliant balloon may be used in the vasculature of a subject. A compliant balloon might also be used in any tube or hole outside the vasculature (whether naturally occurring or man-made, or created during an injury). For a non-limiting example, a compliant balloon might be used in a lumpectomy to put a coating at the site where a tumor was removed, to: treat an abscess, treat an infection, prevent an infection, aid healing, promote healing, or for a combination of any of these purposes. The coating in this embodiment may comprise a growth factor.

[0171] "Non-Compliant balloon" as used herein refers to a balloon that does not conform to the intervention site, but rather, tends to cause the intervention site to conform to the balloon shape. Non-compliant balloons, commonly made from such materials as polyethylene terephthalate (PET) or polyamides, remain at a preselected diameter as the internal balloon pressure increases beyond that required to fully inflate the balloon. Non-compliant balloons are often used to dilate spaces, e.g., vascular lumens. As noted with respect to a compliant balloon, one of skill in the art will be aware that the compliance of a balloon is dependent on the dimensions and/or characteristics of the cavity and/or lumen walls, not only the expandability of the balloon.

[0172] "Cutting balloon" as used herein refers to a balloon commonly used in angioplasty having a special balloon tip with cutting elements, e.g., small blades, wires, etc. The cutting elements can be activated when the balloon is inflated. In angioplasty procedures, small blades can be used score the plaque and the balloon used to compress the fatty matter against the vessel wall. A cutting balloon might have tacks or other wire elements which in some embodiments aid in freeing the coating from the balloon, and in some embodiments, may promote adherence or partial adherence of the coating to the target tissue area, or some combination thereof. In some embodiments, the cutting balloon cutting elements also score the target tissue to promote the coating's introduction into the target tissue. In some embodiments, the cutting elements do not cut tissue at the intervention site. In some embodiments, the cutting balloon comprises tacking elements as the cutting elements.

[0173] "Inflation pressure" as used herein refers to the pressure at which a balloon is inflated. As used herein the nominal inflation pressure refers to the pressure at which a balloon is

inflated in order to achieve a particular balloon dimension, usually a diameter of the balloon as designed. The "rated burst pressure" or "RBP" as used herein refers to the maximum statistically guaranteed pressure to which a balloon can be inflated without failing. For PTCA and PTA catheters, the rated burst pressure is based on the results of in vitro testing to the PTCA and/or PTA catheters, and normally means that at least 99.9% of the balloons tested (with 95% confidence) will not burst at or below this pressure.

[0174] "Tacking element" as used herein refers to an element on the substrate surface that is used to influence transfer of the coating to the intervention site. For example, the tacking element can comprise a projection, e.g., a bump or a spike, on the surface of the substrate. In embodiments, the tacking element is adapted to secure the coating to the cutting balloon until inflation of the cutting balloon. In some embodiments, tacking element can comprise a wire, and the wire can be shaped in the form of an outward pointing wedge. In certain embodiments, the tacking element does not cut tissue at the intervention site.

[0175] As used herein, a "surgical tool" refers to any tool used in a surgical procedure. Examples of surgical tools include, but are not limited to: As used herein, a "surgical tool" refers to any tool used in a surgical procedure. Examples of surgical tools include, but are not limited to: a knife, a scalpel, a guidewire, a guiding catheter, a introduction catheter, a distracter, a needle, a syringe, a biopsy device, an articulator, a Galotti articulator, a bone chisel, a bone crusher, a cottle cartilage crusher, a bone cutter, a bone distractor, an Ilizarov apparatus, an intramedullary kinetic bone distractor, a bone drill, a bone extender, a bone file, a bone lever, a bone mallet, a bone rasp, a bone saw, a bone skid, a bone splint, a bone button, a caliper, a cannula, a catheter, a cautery, a clamp, a coagulator, a curette, a depressor, a dilator, a dissecting knife, a distractor, a dermatome, forceps, dissecting forceps, tissue forceps, sponge forceps, bone forceps, Carmalt forceps, Cushing forceps, Dandy forceps, DeBakey forceps, Doyen intestinal forceps, epilation forceps, Halstead forceps, Kelly forceps, Kocher forceps, mosquito forceps, a hemostat, a hook, a nerve hook, an obstetrical hook, a skin hook, a hypodermic needle, a lancet, a luxator, a lythotome, a lythotript, a mallet, a partsch mallet, a mouth prop, a mouth gag, a mamotome, a needle holder, an occluder, an osteotome, an Epker osteotome, a periosteal elevator, a Joseph elevator, a Molt periosteal elevator, an Obweg periosteal elevator, a septum elevator, a Tessier periosteal elevator, a probe, a retractor, a Senn retractor, a Gelpi retractor, a Weitlaner retractor, a USA-Army/Navy retractor, an O'Connor-O'Sullivan retractor, a Deaver retractor, a Bookwalter retractor, a Sweetheart retractor, a Joseph skin hook, a Lahey retractor, a Blair (Rollet) retractor, a rigid rake retractor, a flexible rake retractor, a Ragnell retractor, a Linde-Ragnell retractor, a Davis retractor, a Volkman retractor, a Mathieu retractor, a Jackson tracheal hook, a Crile retractor, a Meyerding finger retractor, a Little retractor, a Love Nerve retractor, a Green retractor, a Goelet retractor, a Cushing vein retractor, a Langenbeck retractor, a Richardson retractor, a Richardson-Eastmann retractor, a Kelly retractor, a Parker retractor, a Parker-Mott retractor, a Roux retractor, a Mayo-Collins retractor, a Ribbon retractor, an Alm retractor, a self retaining retractor, a Weitlaner retractor, a Beckman-Weitlaner retractor, a Beckman-Eaton retractor, a Beckman retractor, an Adson retractor, a rib spreader, a rongeur, a scalpel, an ultrasonic scalpel, a laser scalpel, scissors, iris scissors, Kiene scissors, Metzenbaum

scissors, Mayo scissors, Tenotomy scissors, a spatula, a speculum, a mouth speculum, a rectal speculum, Sim's vaginal speculum, Cusco's vaginal speculum, a sternal saw, a suction tube, a surgical elevator, a surgical hook, a surgical knife, surgical mesh, a surgical needle, a surgical snare, a surgical sponge, a surgical spoon, a surgical stapler, a suture, a syringe, a tongue depressor, a tonsillotome, a tooth extractor, a towel clamp, towel forceps, Backhaus towel forceps, Lorna towel forceps, a tracheotome, a tissue expander, a subcutaneous inflatable balloon expander, a trephine, a trocar, tweezers, and a venous clipping. In some embodiments, a surgical tool may also and/or alternatively be referred to as a tool for performing a medical procedure. In some embodiments, a surgical tool may also and/or alternatively be a tool for delivering to the intervention site a biomedical implant.

[0176] "Stimulation" as used herein refers to any mechanical stimulation, chemical stimulation, thermal stimulation, electromagnetic stimulation, and/or sonic stimulation that influences, causes, initiates, and/or results in the freeing, dissociation, and/or the transfer of the coating and/or active agent from the substrate.

[0177] "Mechanical Stimulation" as used herein refers to use of a mechanical force that influences the freeing, dissociation, and/or transfer of the coating and/or the active agent from the substrate. For example, mechanical stimulation can comprise a shearing force, a compressive force, a force exerted on the coating from a substrate side of the coating, a force exerted on the coating by the substrate, a force exerted on the coating by an external element, a translation, a rotation, a vibration, or a combination thereof. In embodiments, the mechanical stimulation comprises balloon expansion, stent expansion, etc. In embodiments, the mechanical stimulation is adapted to augment the freeing, dissociation and/or transfer of the coating from the substrate. In embodiments, the mechanical stimulation is adapted to initiate the freeing, dissociation and/or transfer of the coating from the substrate. In embodiments, the mechanical stimulation can be adapted to cause the freeing, dissociation and/or transference of the coating from the substrate. In embodiments, an external element is a part of the subject. In embodiments, the external element is not part of the device. In embodiments the external element comprises a liquid, e.g., saline or water. In certain embodiments the liquid is forced between the coating and the substrate. In embodiments, the mechanical stimulation comprises a geometric configuration of the substrate that maximizes a shear force on the coating.

[0178] "Chemical Stimulation" as used herein refers to use of a chemical force to influence the freeing, dissociation, and/or transfer of the coating from the substrate. For example, chemical stimulation can comprise bulk degradation, interaction with a bodily fluid, interaction with a bodily tissue, a chemical interaction with a non-bodily fluid, a chemical interaction with a chemical, an acid-base reaction, an enzymatic reaction, hydrolysis, or a combination thereof. In embodiments, the chemical stimulation is adapted to augment the freeing, dissociation and/or transfer of the coating from the substrate. In embodiments, the chemical stimulation is adapted to initiate the freeing, dissociation and/or transfer of the coating from the substrate. In embodiments, the chemical stimulation is adapted to cause the freeing, dissociation and/or transfer of the coating from the substrate. In embodiments, the chemical stimulation is achieved through the use of a coating that comprises a material that is adapted to transfer, free, and/or dissociate from the substrate when at the inter-

vention site in response to an in-situ enzymatic reaction resulting in a weak bond between the coating and the substrate.

[0179] "Thermal Stimulation" as used herein refers to use of a thermal stimulus to influence the freeing, dissociation, and/or transfer of the coating from the substrate. For example, thermal stimulation can comprise at least one of a hot stimulus and a cold stimulus. In embodiments, thermal stimulation comprises at least one of a hot stimulus and a cold stimulus adapted to augment the freeing, dissociation and/or transference of the coating from the substrate. In embodiments, thermal stimulation comprises at least one of a hot stimulus and a cold stimulus adapted to initiate the freeing, dissociation and/or transference of the coating from the substrate. In embodiments, thermal stimulation comprises at least one of a hot stimulus and a cold stimulus adapted to cause the freeing, dissociation and/or transference of the coating from the substrate.

[0180] "Electromagnetic Stimulation" as used herein refers to use of an electromagnetic stimulus to influence the freeing, dissociation, and/or transfer of the coating from the substrate. For example, the electromagnetic stimulation is an electromagnetic wave comprising at least one of, e.g., a radio wave, a micro wave, an infrared wave, near infrared wave, a visible light wave, an ultraviolet wave, a X-ray wave, and a gamma wave. In embodiments, the electromagnetic stimulation is adapted to augment the freeing, dissociation and/or transference of the coating from the substrate. In embodiments, the electromagnetic stimulation is adapted to initiate the freeing, dissociation and/or transference of the coating from the substrate. In embodiments, the electromagnetic stimulation is adapted to cause the freeing, dissociation and/or transference of the coating from the substrate.

[0181] "Sonic Stimulation" as used herein refers to use of a sonic stimulus to influence the freeing, dissociation, and/or transfer of the coating from the substrate. For example, sonic stimulation can comprise a sound wave, wherein the sound wave is at least one of an ultrasound wave, an acoustic sound wave, and an infrasound wave. In embodiments, the sonic stimulation is adapted to augment the freeing, dissociation and/or transfer of the coating from the substrate. In embodiments, the sonic stimulation is adapted to initiate the freeing, dissociation and/or transfer of the coating from the substrate. In embodiments, the sonic stimulation is adapted to cause the freeing, dissociation and/or transfer of the coating from the substrate.

[0182] "Release Agent" as used herein refers to a substance or substrate structure that influences the ease, rate, or extent, of release of the coating from the substrate. In certain embodiments wherein the device is adapted to transfer a portion of the coating and/or active agent from the substrate to the intervention site, the device can be so adapted by, e.g., substrate attributes and/or surface modification of the substrate (for non-limiting example: substrate composition, substrate materials, substrate shape, substrate deployment attributes, substrate delivery attributes, substrate pattern, and/or substrate texture), the delivery system of the substrate and coating (for non-limiting example: control over the substrate, control over the coating using the delivery system, the type of delivery system provided, the materials of the delivery system, and/or combinations thereof), coating attributes and/or physical characteristics of the coating (for non-limiting example: selection of the active agent and/or the polymer and/or the polymer-active agent composition, or by the coating having a

particular pattern—e.g. a ribbed pattern, a textured surface, a smooth surface, and/or another pattern, coating thickness, coating layers, and/or another physical and/or compositional attribute), release agent attributes (for non-limiting example: through the selection a particular release agent and/or the manner in which the release agent is employed to transfer the coating and/or the active agent, and/or the amount of the release agent used), and/or a combination thereof. Release agents may include biocompatible release agents, non-bio-compatible release agents to aggravate and/or otherwise induce a healing response or induce inflammation, powder release agents, lubricants (e.g. ePTFE, sugars, other known lubricants), micronized drugs as the release agent (to create a burst layer after the coating is freed from the substrate, physical release agents (patterning of the substrate to free the coating, others), and/or agents that change properties upon insertion (e.g. gels, lipid films, vitamin E, oil, mucosal adhesives, adherent hydrogels, etc.). Methods of patterning a substrate are described, e.g., in U.S. Pat. No. 7,537,610, “Method and system for creating a textured surface on an implantable medical device.” In embodiments, more than one release agent is used, for example, the substrate can be patterned and also lubricated. In some embodiments, the release agent comprises a viscous fluid.

[0183] In some embodiments, the release agent comprises a viscous fluid. In some embodiments, the viscous fluid comprises oil. In some embodiments, the viscous fluid is a fluid that is viscous relative to water. In some embodiments, the viscous fluid is a fluid that is viscous relative to blood. In some embodiments, the viscous fluid is a fluid that is viscous relative to urine. In some embodiments, the viscous fluid is a fluid that is viscous relative to bile. In some embodiments, the viscous fluid is a fluid that is viscous relative to synovial fluid. In some embodiments, the viscous fluid is a fluid that is viscous relative to saline. In some embodiments, the viscous fluid is a fluid that is viscous relative to a bodily fluid at the intervention site.

[0184] In some embodiments, the release agent comprises a physical characteristic of the substrate. In some embodiments, the physical characteristic of the substrate comprises at least one of a patterned coating surface and a ribbed coating surface. In some embodiments, the patterned coating surface comprises a stent framework. In some embodiments, the ribbed coating surface comprises an undulating substrate surface. In some embodiments, the ribbed coating surface comprises a substrate surface having bumps thereon.

[0185] In some embodiments, the release agent comprises a physical characteristic of the coating. In some embodiments, the physical characteristic of the coating comprises a pattern. In some embodiments, the pattern is a textured surface on the substrate side of the coating, wherein the substrate side of the coating is the part of the coating on the substrate. In some embodiments, the pattern is a textured surface on the intervention site side of the coating, wherein the intervention site side of the coating is the part of the coating that is transferred to, and/or delivered to, and/or deposited at the intervention site.

[0186] “Extrusion” and/or “Extruded” and/or to “Extrude” as used herein refers to the movement of a substance away from another substance or object, especially upon stimulation, e.g., by a mechanical force. For example, in embodiments of the invention, the coating is extruded from the substrate.

[0187] Provided herein is a medical device comprising a substrate and a coating on at least a portion of the substrate, wherein the coating comprises an active agent, wherein the coating is patterned, and wherein at least a portion of the coating is adapted to free from the substrate upon stimulation of the coating.

[0188] Provided herein is a medical device comprising a substrate and a coating on at least a portion of the substrate, wherein the coating comprises an active agent, wherein the coating is patterned, and wherein at least a portion of the coating is adapted to dissociate from the substrate upon stimulation of the coating.

[0189] Provided herein is a medical device comprising a substrate and a coating on at least a portion of the substrate, wherein the coating comprises an active agent, wherein the coating is patterned, and wherein at least a portion of the coating is adapted to transfer from the substrate to an intervention site upon stimulation of the coating.

[0190] In some embodiments, the patterned coating comprises at least two different shapes.

[0191] “Patterned” as used herein in reference to the coating refers to a coating having at least two different shapes. The shapes can be formed by various methods, including for example, etching, masking, electrostatic capture, and/or by the coating methods described herein. For example the coating may have voids that are at least partially through the thickness of the coating. In some embodiments, the voids extend fully through the coating. The voids may be in a regular configuration, or irregular in shape. The voids may form a repeating configuration to form the patterned coating. The voids may have been removed from a smooth or solid coating to form a patterned coating. The coating may in some embodiments be patterned by having a surface that is ribbed, wavy or bumpy. The coating may in some embodiments be patterned by having been cut and/or etched from a coating sheath and/or sheet in a particular design. The sheath and/or sheet in such embodiments may have been formed using the coating methods for manufacture as described herein. The pattern design may be chosen to improve the freeing, transfer, and/or dissociation from the substrate. The pattern design may be chosen to improve the transfer and/or delivery to the intervention site.

[0192] Patterned coatings may be created using the methods and processes described herein, for non-limiting example, by providing a substrate having a patterned design thereon comprising, for example, a material that is chosen to selectively capture the coating particles (whether active agent, polymer, or other coating particles) to coat only a desired portion of the substrate. This portion that is coated may be the patterned design of the substrate.

[0193] The term “image enhanced polymer” or “imaging agent” as used herein refer to an agent that can be used with the devices and methods of the invention to view at least one component of the coating, either while the coating is on the substrate or after it is freed, dissociated and/or transferred. In embodiments, an image enhanced polymer serves as a tracer, allowing the movement or location of the coated device to be identified, e.g., using an imaging system. In other embodiments, an image enhanced polymer allows the practitioner to monitor the delivery and movement of a coating component. In embodiments, use of an image enhanced polymer enables the practitioner to determine the dose of a component of the coating (e.g., the active agent) that is freed, dissociated and/or transferred. Information provided by the image enhanced

polymer or imaging agent about the amount of coating transferred to the intervention site can allow the practitioner to determine the rate at which the coating will be released, thereby allowing prediction of dosing over time. Imaging agents may comprise barium compounds such as, for non-limiting example, barium sulfate. Imaging agents may comprise iodine compounds. Imaging agents may comprise any compound that improves radiopacity.

[0194] In embodiments, an image enhanced polymer is used with the device and methods of the invention for a purpose including, but not limited to, one or more of the following: monitoring the location of the substrate, e.g., a balloon or other device; assessing physiological parameters, e.g., flow and perfusion; and targeting to a specific molecule. In embodiments, “smart” agents that activate only in the presence of their intended target are used with the device and methods of the invention.

[0195] Provided herein is a method comprising: providing a medical device, wherein the medical device comprises a substrate and a coating on at least a portion of the substrate, wherein the coating comprises an active agent; and tacking at least a portion of the coating to an intervention site. In some embodiments, the tacking the coating portion (i.e. the portion of the coating) to the intervention site is upon stimulating the coating with a stimulation.

[0196] In some embodiments, the substrate comprises a balloon. In some embodiments, the portion of the balloon having coating thereon comprises an outer surface of the balloon. In some embodiments, the outer surface is a surface of the balloon exposed to a coating prior to balloon folding. In some embodiments, the outer surface is a surface of the balloon exposed to a coating following balloon folding. In some embodiments, the outer surface is a surface of the balloon exposed to a coating following balloon crimping. In some embodiments, the coating comprises a material that undergoes plastic deformation at pressures provided by inflation of the balloon. In some embodiments, the coating comprises a material that undergoes plastic deformation at a pressure that is less than the rated burst pressure of the balloon.

[0197] In some embodiments, the coating comprises a material that undergoes plastic deformation at a pressure that is less than the nominal inflation pressure of the balloon. In some embodiments, the coating comprises a material that undergoes plastic deformation with at least 8 ATM of pressure. In some embodiments, the coating comprises a material that undergoes plastic deformation with at least 6 ATM of pressure. In some embodiments, the coating comprises a material that undergoes plastic deformation with at least 4 ATM of pressure. In some embodiments, the coating comprises a material that undergoes plastic deformation with at least 2 ATM of pressure.

[0198] In some embodiments, the balloon is a compliant balloon. In some embodiments, the balloon is a semi-compliant balloon. In some embodiments, the balloon is a non-compliant balloon. In some embodiments, the balloon conforms to a shape of the intervention site.

[0199] In some embodiments, the balloon comprises a cylindrical portion. In some embodiments, the balloon comprises a substantially spherical portion. In some embodiments, the balloon comprises a complex shape. In some embodiments, the complex shape comprises at least one of a double noded shape, a triple noded shape, a wasted shape, an hourglass shape, and a ribbed shape.

[0200] Some embodiments provide devices that can serve interventional purposes in addition to delivery of therapeutics, such as a cutting balloon. In some embodiments, the substrate comprises a cutting balloon. In some embodiments, the cutting balloon comprises at least one tacking element adapted to tack the coating to the intervention site. In some embodiments, the tacking element is adapted to secure the coating to the cutting balloon until inflation of the cutting balloon. In some embodiments, the tacking element comprises a wire. In some embodiments, the wire is shaped in the form of an outward pointing wedge. In some embodiments, the tacking element does not cut tissue at the intervention site.

[0201] One illustration devices provided herein include a cutting balloon for the treatment of vascular disease (e.g.; occluded lesions in the coronary or peripheral vasculature). In this embodiment, the coating may be preferentially located on the ‘cutting wire’ portion of the device. Upon deployment, the wire pushes into the plaque to provide the desired therapeutic ‘cutting’ action. During this cutting, the polymer and drug coating is plastically deformed off of the wire by the combination of compressive and shear forces acting on the wire—leaving some or all of the coating embedded in the plaque and/or artery wall. A similar approach may be applied to delivery of oncology drugs (a) directly to tumors and/or, (b) to the arteries delivering blood to the tumors for site-specific chemotherapy, and/or (c) to the voids left after the removal of a tumor (lumpectomy). These oncology (as well as other non-vascular) applications may not require the ‘cutting’ aspects and could be provided by coatings directly onto the balloon or onto a sheath over the balloon or according to an embodiment wherein the coating forms a sheath over the deflated (pleated) balloon.

[0202] A cutting balloon embodiment described herein provides several advantages. Such embodiment allows for concentrating the mechanical force on the coating/wire as the balloon is inflated - - - the wire may serve to concentrate the point-of-contact-area of the balloon expansion pressure resulting in a much higher force for plastic deformation of the drug and polymer coating vs. the non-cutting plain balloon which may distribute the pressure over a much larger area (therefore lower force proportional to the ratio of the areas). Embodiments involving a cutting balloon provide for the use of polymers that would otherwise be too rigid (higher modulus) to deform from a non-cutting balloon.

[0203] Other embodiments provided herein are based on geometric configurations of the device that optimize both the deformation and the bulk-migration of the coating from the device. In one embodiment wherein the device is a cutting balloon, the (coated) wire of the cutting balloon is shaped like a wedge, pointed outward.

[0204] Another embodiment provides catheter-based devices where the drug-delivery formulation is delivered to the therapeutic site in the vasculature via inflation of a balloon.

[0205] One embodiment provides coated percutaneous devices (e.g.; balloons, whether cutting balloons or other balloon types) that, upon deployment at a specific site in the patient, transfer some or all of the drug-delivery formulation (5-10%, 10-25%, 25-50%, 50-90%, 90-99%, 99-100%) to the site of therapeutic demand. In certain embodiments, the balloon is at least in part cylindrical as expanded or as formed. In certain embodiments, the balloon is at least in part bulbous as expanded or as formed. In certain embodiments, the balloon is at least in part spherical as expanded or as formed. In certain

embodiments, the balloon has a complex shape as expanded or as formed (such as a double noded shape, a triple noded shape, has a waist, and/or has an hourglass shape, for non-limiting example).

[0206] In some embodiments, transferring at least a portion of the active agent comprises transferring at least about 3%, at least about 5%, at least about 10%, at least about 20%, at least about 30%, greater than 35%, at least about 50%, at least about 75%, at least about 85%, at least about 90%, at least about 95%, and/or at least about 99% of the active agent from the substrate. In some embodiments, stimulating decreases the contact between the coating and the substrate. In some embodiments, transferring transfers less than about 1%, less than about 5%, less than about 10%, less than about 15%, less than about 25%, at most about 35%, less than about 50%, less than about 70%, less than about 80%, and/or less than about 90% of the active agent absent stimulating at least one of the coating and the substrate.

[0207] The term “adapted to transfer at least a portion” of the coating or active agent to an intervention site refers to a device that is designed to transfer any portion of the coating or active agent to an intervention site.

[0208] The term “adapted to free” a portion of a coating and/or active agent from the substrate refers to a device, coating, and/or substrate that is designed to free a certain percentage of the coating and/or active agent from the substrate. As used herein, a device, coating, and/or substrate that is designed to free a certain percentage of the coating and/or active agent from the substrate is designed to unrestraint the coating and/or active agent from the substrate, and/or to remove any obstruction and/or connection the coating may have to the substrate (whether direct or indirect).

[0209] In some embodiments, the device is adapted to free a portion of the coating and/or active agent from the substrate. For non-limiting example, the device is so adapted by substrate attributes (for non-limiting example: substrate composition, substrate materials, shape, substrate deployment attributes, substrate delivery attributes, substrate pattern, and/or substrate texture), the delivery system of the substrate and coating (for non-limiting example: control over the substrate, control over the coating using the delivery system, the type of delivery system provided, the materials of the delivery system, and/or combinations thereof), coating attributes (for non-limiting example: selection of the active agent and/or the polymer and/or the polymer-active agent composition, or by the coating having a particular pattern—e.g. a ribbed pattern, a textured surface, a smooth surface, and/or another pattern, coating thickness, coating layers, and/or another physical and/or compositional attribute), release agent attributes (for non-limiting example: through the selection a particular release agent and/or how the release agent is employed to transfer the coating and/or the active agent, and/or how much of the release agent is used), and/or a combination thereof.

[0210] In some embodiments, the substrate is adapted to free a portion of the coating and/or active agent from the substrate. For non-limiting example, the substrate is so adapted by selection of the substrate composition, substrate materials, shape, substrate deployment attributes, substrate delivery attributes, substrate pattern, and/or substrate texture, and/or combinations thereof. For example, a balloon can be designed to only partially inflate within the confines of the intervention site. Partial inflation can prevent a designated portion of coating from being freed.

[0211] In some embodiments, the coating is adapted to free a portion of the coating and/or active agent from the substrate. For non-limiting example the coating may be so adapted by selection of the active agent and/or the polymer and/or the polymer-active agent composition, or by the coating having a particular pattern—e.g. a ribbed pattern, a textured surface, a smooth surface, and/or another pattern, coating thickness, coating layers, and/or another physical and/or compositional attribute.

[0212] In some embodiments, the substrate is adapted to free a portion of the coating and/or active agent from the substrate to the intervention site. For non-limiting example, the substrate is so adapted by selection of the substrate composition, substrate materials, shape, substrate deployment attributes, substrate delivery attributes, substrate pattern, and/or substrate texture, and/or combinations thereof. For example, a balloon can be designed to only partially inflate within the confines of the intervention site. Partial inflation can prevent a designated portion of coating from being freed.

[0213] In some embodiments, the coating is adapted to free a portion of the coating and/or active agent from the substrate to the intervention site. For non-limiting example the coating may be so adapted by selection of the active agent and/or the polymer and/or the polymer-active agent composition, or by the coating having a particular pattern—e.g. a ribbed pattern, a textured surface, a smooth surface, and/or another pattern, coating thickness, coating layers, and/or another physical and/or compositional attribute.

[0214] In some embodiments, freeing at least a portion of the coating comprises freeing at least about 10%, at least about 20%, at least about 30%, greater than 35%, at least about 50%, at least about 75%, at least about 85%, at least about 90%, at least about 95%, and/or at least about 99% of the coating from the substrate. In some embodiments, stimulating decreases the contact between the coating and the substrate. In some embodiments, freeing frees less than about 1%, less than about 5%, less than about 10%, less than about 15%, less than about 25%, at most about 35%, less than about 50%, less than about 70%, less than about 80%, and/or less than about 90% of the coating absent stimulating at least one of the coating and the substrate.

[0215] The term “adapted to dissociate” a portion of a coating and/or active agent from the substrate refers to a device, coating, and/or substrate that is designed to dissociate a certain percentage of the coating and/or active agent from the substrate. As used herein, a device, coating, and/or substrate that is designed to dissociate a certain percentage of the coating and/or active agent from the substrate is designed to remove from association between the coating (and/or active agent) and the substrate. Also and/or alternatively, as used herein, a device, coating, and/or substrate that is designed to dissociate a certain percentage of the coating and/or active agent from the substrate is designed to separate the coating (and/or active agent) from the substrate. This separation may be reversible in some embodiments. This separation may not be reversible in some embodiments.

[0216] In some embodiments, the device is adapted to dissociate a portion of the coating and/or active agent from the substrate. For non-limiting example, the device is so adapted by substrate attributes (for non-limiting example: substrate composition, substrate materials, shape, substrate deployment attributes, substrate delivery attributes, substrate pattern, and/or substrate texture), the delivery system of the substrate and coating (for non-limiting example: control over

the substrate, control over the coating using the delivery system, the type of delivery system provided, the materials of the delivery system, and/or combinations thereof), coating attributes (for non-limiting example: selection of the active agent and/or the polymer and/or the polymer-active agent composition, or by the coating having a particular pattern—e.g. a ribbed pattern, a textured surface, a smooth surface, and/or another pattern, coating thickness, coating layers, and/or another physical and/or compositional attribute), release agent attributes (for non-limiting example: through the selection a particular release agent and/or how the release agent is employed to transfer the coating and/or the active agent, and/or how much of the release agent is used), and/or a combination thereof.

[0217] In some embodiments, the substrate is adapted to dissociate a portion of the coating and/or active agent from the substrate. For non-limiting example, the substrate is so adapted by selection of the substrate composition, substrate materials, shape, substrate deployment attributes, substrate delivery attributes, substrate pattern, and/or substrate texture, and/or combinations thereof. For example, a balloon can be designed to only partially inflate within the confines of the intervention site. Partial inflation can prevent a designated portion of coating from being freed.

[0218] In some embodiments, the coating is adapted to dissociate a portion of the coating and/or active agent from the substrate. For non-limiting example the coating may be so adapted by selection of the active agent and/or the polymer and/or the polymer-active agent composition, or by the coating having a particular pattern—e.g. a ribbed pattern, a textured surface, a smooth surface, and/or another pattern, coating thickness, coating layers, and/or another physical and/or compositional attribute.

[0219] In some embodiments, the substrate is adapted to free a portion of the coating and/or active agent from the substrate to the intervention site. For non-limiting example, the substrate is so adapted by selection of the substrate composition, substrate materials, shape, substrate deployment attributes, substrate delivery attributes, substrate pattern, and/or substrate texture, and/or combinations thereof. For example, a balloon can be designed to only partially inflate within the confines of the intervention site. Partial inflation can prevent a designated portion of coating from being freed.

[0220] In some embodiments, the coating is adapted to dissociate a portion of the coating and/or active agent from the substrate to the intervention site. For non-limiting example the coating may be so adapted by selection of the active agent and/or the polymer and/or the polymer-active agent composition, or by the coating having a particular pattern—e.g. a ribbed pattern, a textured surface, a smooth surface, and/or another pattern, coating thickness, coating layers, and/or another physical and/or compositional attribute.

[0221] In some embodiments, dissociating at least a portion of the coating comprises dissociating at least about 10%, at least about 20%, at least about 30%, greater than 35%, at least about 50%, at least about 75%, at least about 85%, at least about 90%, at least about 95%, and/or at least about 99% of the coating from the substrate. In some embodiments, stimulating decreases the contact between the coating and the substrate. In some embodiments, dissociating dissociates less than about 1%, less than about 5%, less than about 10%, less than about 15%, less than about 25%, at most about 35%, less than about 50%, less than about 70%, less than about 80%,

and/or less than about 90% of the coating absent stimulating at least one of the coating and the substrate.

[0222] “Plastic deformation” as used herein is the change in the physical shape of the coating by forces induced on the device. Plastic deformation results in increasing the contact area of the coating on the tissue and decreasing the contact area of the coating on the device. This change in contact area results in some or all of the coating being preferentially exposed to the tissue instead of the device. The terms “plastic deformation” and “plastically deform,” as used herein in the context of a coating, are intended to include the expansion of the coating material beyond the elastic limit of the material such that the material is permanently deformed. “Elastic deformation” as used herein refers to a reversible alteration of the form or dimensions of the object under stress or strain, e.g., inflation pressure of a balloon substrate. The terms “plastic deformation” and “plastically deform,” as used herein in the context of a balloon or other substrate, are intended to include the expansion of the substrate beyond the elastic limit of the substrate material such that the substrate material is permanently deformed. Once plastically deformed, a material becomes substantially inelastic and generally will not, on its own, return to its pre-expansion size and shape. “Residual plastic deformation” refers to a deformation capable of remaining at least partially after removal of the inflation stress, e.g., when the balloon is deflated. “Elastic deformation” as used herein refers to a reversible alteration of the form or dimensions of the object (whether it is the coating or the substrate) under stress or strain, e.g., inflation pressure.

[0223] “Shear transfer” as used herein is the force (or component of forces) orthogonal to the device that would drive the coating away from the device substrate. This could be induced on the device by deployment, pressure-response from the surrounding tissue and/or in-growth of tissue around the coating.

[0224] “Bulk migration” as used herein is the incorporation of the coating onto/into the tissue provided by the removal of the device and/or provided by degradation of the coating over time and/or provided by hydration of the coating over time. Degradation and hydration of the coating may reduce the coating’s cohesive and adhesive binding to the device, thereby facilitating transfer of the coating to the tissue.

[0225] One embodiment may be described by analogy to contact printing whereby a biochemically active ‘ink’ (the polymer+drug coating) from a ‘die’ (the device) to the ‘stock’ (the site in the body).

[0226] The devices and methods described in conjunction with some of the embodiments provided herein are advantageously based on specific properties provided for in the drug-delivery formulation. One such property, especially well-suited for non-permanent implants such as balloon catheters, cutting balloons, etc. is ‘soft’ coating that undergoes plastic deformation at pressures provided by the inflation of the balloon (range 2-25 ATM, typically 10-18 ATM). Another such property, especially well-suited to permanent implants such as stents is coatings where the polymer becomes ‘soft’ at some point after implant either by hydration or by degradation or by combinations of hydration and degradation.

[0227] Some embodiments provide devices that can advantageously be used in conjunction with methods that can aid/promote the transfer of the coating. These include introducing stimuli to the coated device once on-site in the body (where the device is delivered either transiently or permanently). Such stimuli can be provided to induce a chemical response

(light, heat, radiation, etc.) in the coating or can provide mechanical forces to augment the transfer of the coating into the tissue (ultrasound, translation, rotation, vibration and combinations thereof).

[0228] In some embodiments, the coating is freed, dissociated, and/or transferred from the substrate using a mechanical stimulation. In some embodiments, the coating is freed from the substrate using a mechanical stimulation. In some embodiments, the coating is dissociated from the substrate using a mechanical stimulation. In some embodiments, the coating is transferred from the substrate using a mechanical stimulation. In some embodiments, the coating is transferred to the intervention site using a mechanical stimulation. In some embodiments, the coating is delivered to the intervention site using a mechanical stimulation. In some embodiments, the mechanical stimulation is adapted to augment the freeing, dissociation and/or transference of the coating from the substrate. In some embodiments, the mechanical stimulation is adapted to initiate the freeing, dissociation and/or transference of the coating from the substrate. In some embodiments, the mechanical stimulation is adapted to cause the freeing, dissociation and/or transference of the coating from the substrate. In some embodiments, the mechanical stimulation comprises at least one of a compressive force, a shear force, a tensile force, a force exerted on the coating from a substrate side of the coating, a force exerted on the coating by the substrate, a force exerted on the coating from an external element, a translation, a rotation, a vibration, and a combination thereof. In some embodiments, the external element is a part of the subject. In some embodiments, the external element is not part of the device. In some embodiments, the external element comprises a liquid. In some embodiments, the liquid is forced between the coating and the substrate. In some embodiments, the liquid comprises saline. In some embodiments, the liquid comprises water. In some embodiments, the mechanical stimulation comprises a geometric configuration of the substrate that maximizes a shear force on the coating. In some embodiments, the mechanical stimulation comprises a geometric configuration of the substrate that increases a shear force on the coating. In some embodiments, the mechanical stimulation comprises a geometric configuration of the substrate that enhances a shear force on the coating.

[0229] In some embodiments, the coating is freed, dissociated, and/or transferred from the substrate using a chemical stimulation. In some embodiments, the coating is freed from the substrate using a chemical stimulation. In some embodiments, the coating is dissociated from the substrate using a chemical stimulation. In some embodiments, the coating is transferred from the substrate using a chemical stimulation. In some embodiments, the coating is transferred to the intervention site using a chemical stimulation. In some embodiments, the coating is delivered to the intervention site using a chemical stimulation. In some embodiments, the chemical stimulation comprises at least one of bulk degradation, interaction with a bodily fluid, interaction with a bodily tissue, a chemical interaction with a non-bodily fluid, a chemical interaction with a chemical, an acid-base reaction, an enzymatic reaction, hydrolysis, and combinations thereof. In some embodiments, the chemical stimulation comprises bulk degradation of the coating. In some embodiments, the chemical stimulation comprises interaction of the coating or a portion thereof with a bodily fluid. In some embodiments, the chemical stimulation comprises interaction of the coating or a por-

tion thereof with a bodily tissue. In some embodiments, the chemical stimulation comprises a chemical interaction of the coating or a portion thereof with a non-bodily fluid. In some embodiments, the chemical stimulation comprises a chemical interaction of the coating or a portion thereof with a chemical. In some embodiments, the chemical stimulation comprises an acid-base reaction. In some embodiments, the chemical stimulation comprises an enzymatic reaction. In some embodiments, the chemical stimulation comprises hydrolysis.

[0230] In some embodiments, the chemical stimulation is adapted to augment the freeing, dissociation and/or transference of the coating from the substrate. In some embodiments, the chemical stimulation is adapted to initiate the freeing, dissociation and/or transference of the coating from the substrate. In some embodiments, the chemical stimulation is adapted to cause the freeing, dissociation and/or transference of the coating from the substrate. In some embodiments, the coating comprises a material that is adapted to transfer, free, and/or dissociate from the substrate when at the intervention site in response to an in-situ enzymatic reaction resulting in a weak bond between the coating and the substrate.

[0231] In some embodiments, the coating is freed, dissociated, and/or transferred from the substrate using a thermal stimulation. In some embodiments, the coating is freed from the substrate using a thermal stimulation. In some embodiments, the coating is dissociated from the substrate using a thermal stimulation. In some embodiments, the coating is transferred from the substrate using a thermal stimulation. In some embodiments, the coating is transferred to the intervention site using a thermal stimulation. In some embodiments, the coating is delivered to the intervention site using a thermal stimulation. In some embodiments, the thermal stimulation comprises at least one of a hot stimulus and a cold stimulus adapted to augment the freeing, dissociation and/or transference of the coating from the substrate. In some embodiments, the thermal stimulation is adapted to cause the freeing, dissociation and/or transference of the coating from the substrate. In some embodiments, the thermal stimulation comprises at least one of a hot stimulus and a cold stimulus adapted to initiate the freeing, dissociation and/or transference of the coating from the substrate. In some embodiments, the thermal stimulation comprises at least one of a hot stimulus and a cold stimulus adapted to initiate the freeing, dissociation and/or transference of the coating from the substrate.

[0232] In some embodiments, the coating is freed, dissociated, and/or transferred from the device by an electromagnetic stimulation. In some embodiments, the coating is freed from the substrate using an electromagnetic stimulation. In some embodiments, the coating is dissociated from the substrate using an electromagnetic stimulation. In some embodiments, the coating is transferred from the substrate using an electromagnetic stimulation. In some embodiments, the coating is transferred to the intervention site using an electromagnetic stimulation. In some embodiments, the coating is delivered to the intervention site using an electromagnetic stimulation. In some embodiments, the electromagnetic stimulation comprises an electromagnetic wave comprising at least one of a radio wave, a micro wave, an infrared wave, near infrared wave, a visible light wave, an ultraviolet wave, an X-ray wave, and a gamma wave. In some embodiments, the electromagnetic stimulation is adapted to augment the freeing, dissociation and/or transference of the coating from the substrate. In some embodiments, the electromagnetic stimulation is

adapted to initiate the freeing, dissociation and/or transference of the coating from the substrate. In some embodiments, the electromagnetic stimulation is adapted to cause the freeing, dissociation and/or transference of the coating from the substrate.

[0233] In some embodiments, the coating is freed, dissociated, and/or transferred from the device by a sonic stimulation. In some embodiments, the coating is freed from the substrate using a sonic stimulation. In some embodiments, the coating is dissociated from the substrate using a sonic stimulation. In some embodiments, the coating is transferred from the substrate using a sonic stimulation. In some embodiments, the coating is transferred to the intervention site using a sonic stimulation. In some embodiments, the coating is delivered to the intervention site using a sonic stimulation. In some embodiments, the sonic stimulation comprises a sound wave, wherein the sound wave is at least one of an ultrasound wave, an acoustic sound wave, and an infrasound wave. In some embodiments, the sonic stimulation is adapted to augment the freeing, dissociation and/or transference of the coating from the substrate. In some embodiments, the sonic stimulation is adapted to initiate the freeing, dissociation and/or transference of the coating from the substrate. In some embodiments, the sonic stimulation is adapted to cause the freeing, dissociation and/or transference of the coating from the substrate.

[0234] In some embodiments, the coating is freed, dissociated, and/or transferred from the device by a combination of at least two of a mechanical stimulation, a chemical stimulation, an electromagnetic stimulation, and a sonic stimulation.

[0235] In some embodiments, the coating is freed, dissociated, and/or transferred from the substrate by extrusion.

[0236] Provided herein are device geometries that maximize the shear forces on the coating. Such geometric design of the device provides two advantages: (1) increases (concentrates) the force to plastically deform the drug and polymer coating (2) decreases the force of adhesion of the coating. For example, a wedge-shape aligns the forces of deformation along a shear plan as opposed to direct compression. This embodiment provides for: (1) increased efficiency in terms of % of the coating transferred (2) increased precision in amount transferred on a case-by-case basis (3) utilization of 'harder/stiffer' materials (biopolymers) that would otherwise not deform and/or not bulk-migrate under deployment conditions (4) minimize the chance of particulate shedding via purposefully designing the shape and direction of both the deformation and bulk migration. For example for a wedge, particles would be less likely because the coating would be pre-disposed as a shear from the device in a sheet form—with the use of soft materials, this may be illustrated as a coating of silicone caulk being extruded from the pressure of a rod being pushed into a mattress.

[0237] Another embodiment provide a geometric arrangement of the coating whereby layers, e.g. a laminate structure, are provided in the coating to modulate and control the plastic deformation, shearing and bulk-migration of the coating into the tissue.

[0238] One embodiment provides coated substrates that, upon deployment at a specific site in the patient, transfer some or all of the coating (5-10%, 10-25%, 25-50%, 50-90%, 90-99%, 99-100%) to the site of therapeutic demand.

[0239] In some embodiments, the device further comprises a release agent. In some embodiments, the release agent is biocompatible. In some embodiments, the release agent is

non-biocompatible. In some embodiments, the release agent comprises a powder. In some embodiments, the release agent comprises a lubricant. In some embodiments, the release agent comprises a surface modification of the substrate.

[0240] In some embodiments, the release agent comprises a physical characteristic of the coating. In some embodiments, the physical characteristic of the coating comprises a pattern. In some embodiments, the pattern is a textured surface on the substrate side of the coating, wherein the substrate side of the coating is the part of the coating on the substrate. In some embodiments, the pattern is a textured surface on the intervention site side of the coating, wherein the intervention site side of the coating is the part of the coating that is transferred to, and/or delivered to, and/or deposited at the intervention site.

[0241] In some embodiments, the release agent comprises a viscous fluid. In some embodiments, the viscous fluid comprises oil. In some embodiments, the viscous fluid is a fluid that is viscous relative to water. In some embodiments, the viscous fluid is a fluid that is viscous relative to blood. In some embodiments, the viscous fluid is a fluid that is viscous relative to urine. In some embodiments, the viscous fluid is a fluid that is viscous relative to bile. In some embodiments, the viscous fluid is a fluid that is viscous relative to synovial fluid. In some embodiments, the viscous fluid is a fluid that is viscous relative to saline. In some embodiments, the viscous fluid is a fluid that is viscous relative to a bodily fluid at the intervention site.

[0242] In some embodiments, the release agent comprises a gel.

[0243] In some embodiments, the release agent comprises at least one of the active agent and another active agent. The active agent may be placed on the substrate prior to the coating in order to act as the release agent. The active agent may be a different active agent than the active agent in the coating. The active agent that is the release agent may provide for a second source of drug to be delivered to the intervention site or another location once the coating is released from (or transferred from, or freed from, or dissociated from) the substrate.

[0244] In some embodiments, the release agent comprises a physical characteristic of the substrate. In some embodiments, the physical characteristic of the substrate comprises at least one of a patterned coating surface and a ribbed coating surface. In some embodiments, the patterned coating surface comprises a stent framework. In some embodiments, the ribbed coating surface comprises an undulating substrate surface. In some embodiments, the ribbed coating surface comprises an substrate surface having bumps thereon.

[0245] In some embodiments, the release agent comprises a property that is capable of changing at the intervention site. In some embodiments, the property comprises a physical property. In some embodiments, the property comprises a chemical property. In some embodiments, the release agent is capable of changing a property when in contact with at least one of a biologic tissue and a biologic fluid. In some embodiments, the release agent is capable of changing a property when in contact with an aqueous liquid.

[0246] In some embodiments, the release agent is between the substrate and the coating.

Methods of Manufacturing Generally

[0247] In some embodiments, a coating is formed on the substrate by a process comprising depositing a polymer and/

or the active agent by an e-RESS, an e-SEDS, or an e-DPC process. In some embodiments, the process of forming the coating provides improved adherence of the coating to the substrate prior to deployment of the device at the intervention site and facilitates dissociation of the coating from the substrate at the intervention site. In some embodiments, the coating is formed on the substrate by a process comprising depositing the active agent by an e-RESS, an e-SEDS, or an e-DPC process without electrically charging the substrate. In some embodiments, the coating is formed on the substrate by a process comprising depositing the active agent on the substrate by an e-RESS, an e-SEDS, or an e-DPC process without creating an electrical potential between the substrate and a coating apparatus used to deposit the active agent.

[0248] Means for creating the bioabsorbable polymer(s)+drug (s) coating of the device with or without a substrate:

[0249] Spray coat the coating-form with drug and polymer as is done in Micell process (e-RESS, e-DPC, compressed-gas sintering).

[0250] Perform multiple and sequential coating—sintering steps where different materials may be deposited in each step, thus creating a laminated structure with a multitude of thin layers of drug(s), polymer(s) or drug+polymer that build the final device.

[0251] Perform the deposition of polymer(s)+drug(s) laminates with the inclusion of a mask on the inner (luminal) surface of the device. Such a mask could be as simple as a non-conductive mandrel inserted through the internal diameter of the coating form. This masking could take place prior to any layers being added, or be purposefully inserted after several layers are deposited continuously around the entire coating-form.

[0252] In some embodiments, the coating comprises a microstructure. In some embodiments, particles of the active agent are sequestered or encapsulated within the microstructure. In some embodiments, the microstructure comprises microchannels, micropores and/or microcavities. In some embodiments, the microstructure is selected to allow sustained release of the active agent. In some embodiments, the microstructure is selected to allow controlled release of the active agent.

[0253] Other methods for preparing the coating include solvent based coating methods and plasma based coating methods. In some embodiments, the coating is prepared by a solvent based coating method. In some embodiments, the coating is prepared by a solvent plasma based coating method.

[0254] Another advantage of the present invention is the ability to create a delivery device with a controlled (dialed-in) drug-elution profile. Via the ability to have different materials in each layer of the laminate structure and the ability to control the location of drug(s) independently in these layers, the method enables a device that could release drugs at very specific elution profiles, programmed sequential and/or parallel elution profiles. Also, the present invention allows controlled elution of one drug without affecting the elution of a second drug (or different doses of the same drug).

[0255] Provided herein is a method of forming a medical device comprising a substrate and a coating on at least a portion of the substrate, wherein the coating comprises an active agent, the method comprising: providing the substrate; and forming the coating on at least a portion of the substrate by depositing the active agent by on the substrate by at least one of an e-RESS, an e-SEDS, and an e-DPC process,

wherein forming the coating results in at least a portion of the coating being adapted to transfer from the substrate to an intervention site upon stimulating the coating with a stimulation.

[0256] Provided herein is a method of forming a medical device comprising a substrate and a coating on at least a portion of the substrate, wherein the coating comprises an active agent, the method comprising: providing the substrate; and forming the coating on at least a portion of the substrate by depositing the active agent by on the substrate by at least one of an e-RESS, an e-SEDS, and an e-DPC process without electrically charging the substrate, wherein forming the coating results in at least a portion of the coating being adapted to transfer from the substrate to an intervention site upon stimulating the coating with a stimulation.

[0257] Provided herein is a method of forming a medical device comprising a substrate and a coating on at least a portion of the substrate, wherein the coating comprises an active agent, the method comprising: providing the substrate; and forming the coating on at least a portion of the substrate by depositing the active agent by on the substrate by at least one of an e-RESS, an e-SEDS, and an e-DPC process without creating an electrical potential between the substrate and a coating apparatus used in the at least one e-RESS, an e-SEDS, and an e-DPC process, wherein forming the coating results in at least a portion of the coating being adapted to transfer from the substrate to an intervention site upon stimulating the coating with a stimulation.

[0258] Provided herein is a method of forming a medical device comprising a substrate and a coating on at least a portion of the substrate, wherein the coating comprises an active agent, the method comprising: providing the substrate; and forming the coating on at least a portion of the substrate by depositing the active agent by on the substrate by at least one of a dipping and/or a spraying process, wherein forming the coating results in at least a portion of the coating being adapted to transfer from the substrate to an intervention site upon stimulating the coating with a stimulation.

[0259] Provided herein is a method of forming a medical device comprising a substrate and a coating on at least a portion of the substrate, wherein the coating comprises an active agent, the method comprising: providing the substrate; and forming the coating on at least a portion of the substrate by depositing the active agent by on the substrate by at least one of an e-RESS, an e-SEDS, and an e-DPC process, wherein forming the coating results in at least a portion of the coating being adapted to free from the substrate upon stimulating the coating with a stimulation.

[0260] Provided herein is a method of forming a medical device comprising a substrate and a coating on at least a portion of the substrate, wherein the coating comprises an active agent, the method comprising: providing the substrate; and forming the coating on at least a portion of the substrate by depositing the active agent by on the substrate by at least one of a dipping and/or a spraying process, wherein forming the coating results in at least a portion of the coating being adapted to free from the substrate upon stimulating the coating with a stimulation.

[0261] Provided herein is a method of forming a medical device comprising a substrate and a coating on at least a portion of the substrate, wherein the coating comprises an active agent, the method comprising: providing the substrate; and forming the coating on at least a portion of the substrate by depositing the active agent by on the substrate by at least

one of an e-RESS, an e-SEDS, and an e-DPC process, wherein forming the coating results in at least a portion of the coating being adapted to dissociate from the substrate upon stimulating the coating with a stimulation.

[0262] Provided herein is a method of forming a medical device comprising a substrate and a coating on at least a portion of the substrate, wherein the coating comprises an active agent, the method comprising: providing the substrate; and forming the coating on at least a portion of the substrate by depositing the active agent by on the substrate by at least one of a dipping and/or a spraying process, wherein forming the coating results in at least a portion of the coating being adapted to dissociate from the substrate upon stimulating the coating with a stimulation.

[0263] Provided herein is a method of forming a medical device comprising a substrate and a coating on at least a portion of the substrate, wherein the coating comprises an active agent, the method comprising: providing the substrate; and forming the coating on at least a portion of the substrate by depositing the active agent by on the substrate by at least one of an e-RESS, an e-SEDS, and an e-DPC process, wherein forming the coating results in at least a portion of the coating being adapted to deliver to the intervention site upon stimulating the coating with a stimulation.

[0264] Provided herein is a method of forming a medical device comprising a substrate and a coating on at least a portion of the substrate, wherein the coating comprises an active agent, the method comprising: providing the substrate; and forming the coating on at least a portion of the substrate by depositing the active agent by on the substrate by at least one of a dipping and/or a spraying process, wherein forming the coating results in at least a portion of the coating being adapted to deliver to the intervention site upon stimulating the coating with a stimulation.

[0265] In some embodiments, the e-RESS, the e-SEDS, and/or the e-DPC process used in forming the coating is performed without electrically charging the substrate. In some embodiments, the e-RESS, the e-SEDS, and/or the e-DPC process used in forming the coating is performed without creating an electrical potential between the substrate and the coating apparatus used in the e-RESS, the e-SEDS, and/or the e-DPC process.

[0266] In some embodiments, forming the coating results in the coating adhering to the substrate prior to the substrate reaching the intervention site.

[0267] Some embodiments further comprise providing a release agent on the substrate. In some embodiments, providing the release agent step is performed prior to the forming the coating step. In some embodiments, the release agent comprises at least one of: a biocompatible release agent, a non-biocompatible release agent, a powder, a lubricant, a surface modification of the substrate, a viscous fluid, a gel, the active agent, a second active agent, a physical characteristic of the substrate. In some embodiments, the physical characteristic of the substrate comprises at least one of: a patterned coating surface of the substrate, and a ribbed surface of the substrate. In some embodiments, the release agent comprises a property that is capable of changing at the intervention site. In some embodiments, the property comprises a physical property. In some embodiments, the property comprises a chemical property. In some embodiments, the release agent is capable of changing a property when in contact with at least one of a biologic tissue and a biologic fluid. In some embodiments, the release agent is capable of changing a property when in con-

tact with an aqueous liquid. In some embodiments, the coating results in a coating property that facilitates transfer of the coating to the intervention site. In some embodiments, the coating property comprises a physical characteristic of the coating. In some embodiments, the physical characteristic comprises a pattern.

[0268] In some embodiments, forming the coating facilitates transfer of the coating to the intervention site.

[0269] In some embodiments, transferring, freeing, dissociating, depositing, and/or tacking step comprises softening the polymer by hydration, degradation or by a combination of hydration and degradation. In some embodiments, the transferring, freeing, dissociating, depositing, and/or tacking step comprises softening the polymer by hydrolysis of the polymer.

[0270] In some embodiments, the providing step comprises forming the coating by a solvent based coating method. In some embodiments, the providing step comprises forming the coating by a solvent plasma based method.

[0271] In some embodiments, providing the device comprises depositing a plurality of layers on the substrate to form the coating, wherein at least one of the layers comprises the active agent. In some embodiments, at least one of the layers comprises a polymer. In some embodiments, the polymer is bioabsorbable. In some embodiments, the active agent and the polymer are in the same layer, in separate layers, or form overlapping layers. In some embodiments, the plurality of layers comprise five layers deposited as follows: a first polymer layer, a first active agent layer, a second polymer layer, a second active agent layer and a third polymer layer.

EXAMPLES

[0272] The following examples are provided to illustrate selected embodiments. They should not be considered as limiting the scope of the invention, but merely as being illustrative and representative thereof. For each example listed herein, multiple analytical techniques may be provided. Any single technique of the multiple techniques listed may be sufficient to indicate the parameter and/or characteristic being tested, or any combination of techniques may be used to indicate such parameter and/or characteristic. Those skilled in the art will be familiar with a wide range of analytical techniques for the characterization of drug/polymer coatings. Techniques presented here, but not limited to, may be used to additionally and/or alternatively characterize specific properties of the coatings with variations and adjustments employed which would be obvious to those skilled in the art.

Sample Preparation

[0273] Generally speaking, coatings on stents, on balloons, on coupons, on other substrates, or on samples prepared for in-vivo models are prepared as herein. Nevertheless, modifications for a given analytical method are presented within the examples described, and/or would be obvious to one having skill in the art. Thus, numerous variations, changes, and substitutions will now occur to those skilled in the art without departing from the invention. It should be understood that various alternatives to the embodiments of the invention described herein and examples provided may be employed in practicing the invention and indicating the parameters and/or characteristics described.

Coatings on Balloons

[0274] Coated balloons as described herein and/or made by a method disclosed herein are prepared. In some examples, the coated balloons have a targeted coating thickness of ~15 microns (~5 microns of active agent). In some examples, the coating process is PDPDP (Polymer, sinter, Drug, Polymer, sinter, Drug, Polymer, sinter) using deposition of drug in dry powder form and deposition of polymer particles by RESS methods and equipment described herein. In the illustrations herein, resulting coated balloons may have a 3-layer coating comprising polymer (for example, PLGA) in the first layer, drug (for example, rapamycin) in a second layer and polymer in the third layer, where a portion of the third layer is substantially drug free (e.g. a sub-layer within the third layer having a thickness equal to a fraction of the thickness of the third layer). As described layer, the middle layer (or drug layer) may be overlapping with one or both first (polymer) and third (polymer) layer. The overlap between the drug layer and the polymer layers is defined by extension of polymer material into physical space largely occupied by the drug. The overlap between the drug and polymer layers may relate to partial packing of the drug particles during the formation of the drug layer. When crystal drug particles are deposited on top of the first polymer layer, voids and or gaps may remain between dry crystal particles. The voids and gaps are available to be occupied by particles deposited during the formation of the third (polymer) layer. Some of the particles from the third (polymer) layer may rest in the vicinity of drug particles in the second (drug) layer. When the sintering step is completed for the third (polymer) layer, the third polymer layer particles fuse to form a continuous film that forms the third (polymer) layer. In some embodiments, the third (polymer) layer however will have a portion along the longitudinal axis of the stent whereby the portion is free of contacts between polymer material and drug particles. The portion of the third layer that is substantially of contact with drug particles can be as thin as 1 nanometer.

[0275] Polymer-coated balloons having coatings comprising polymer but no drug are made by a method disclosed herein and are prepared having a targeted coating thickness of, for example, about 0.5, 1, 2, 3, 4, 5, 10, 15, 20, 25, 30, 35, 40, 45, or 50 microns, depending in part on whether the coating expands upon hydration and if so whether it is hydrated. In embodiments, the coating thickness is 1-5 microns. In other embodiments, it is 1-10 microns.

[0276] An example coating process is PPP (PLGA, sinter, PLGA, sinter, PLGA, sinter) using RESS methods and equipment described herein. These polymer-coated balloons may be used as control samples in some of the examples, *infra*.

[0277] In some examples, the balloons are made of a compliant polymer. In some examples, the balloons are made of a non-compliant polymer. The balloons may be, in some examples, 5 to 50 mm in length, preferably 10-20 mm in length.

[0278] Balloons can be coated while inflated, and later compacted, or they can be coated while uninflated. If a balloon is coated while inflated and later folded or otherwise compacted, then a portion of the coating can be protected during insertion by virtue of being disposed within the portion of the balloon that is not exposed until inflation. The coating can also be protected by using a sheath or other covering, as described in the art for facilitating insertion of an angioplasty balloon.

[0279] The coating released from a balloon may be analyzed (for example, for analysis of a coating band and/or coating a portion of the balloon). Alternatively, in some examples, the coating is analyzed directly on the balloon. This coating, and/or coating and balloon, may be sliced into sections which may be turned 90 degrees and visualized using the surface composition techniques presented herein or other techniques known in the art for surface composition analysis (or other characteristics, such as crystallinity, for example). In this way, what could be an analysis of coating composition through a depth when the coating is on the balloon or as removed from the balloon (i.e. a depth from the abluminal surface of the coating to the surface of the removed coating that once contacted the balloon or a portion thereof), becomes a surface analysis of the coating which can, for example, indicate the layers in the slice of coating, at much higher resolution. Residual coating on an extracted balloon also can be analyzed and compared to the amount of coating on an unused balloon, using, e.g., HPLC, as noted herein. Coating removed from the balloon, or analyzed without removal and/or release from the balloon, may be treated the same way, and assayed, visualized, and/or characterized as presented herein using the techniques described and/or other techniques known to a person of skill in the art.

Sample Preparation for In-Vivo Models

[0280] Devices comprising balloons having coatings disclosed herein are deployed in the porcine coronary arteries of pigs (domestic swine, juvenile farm pigs, or Yucatan miniature swine). Porcine coronary angioplasty is exploited herein since such model yields results that are comparable to other investigations assaying neointimal hyperplasia in human subjects. The balloons are expanded to a 1:1.1 balloon: artery ratio. At multiple time points, animals are euthanized (e.g. t=1 day, 7 days, 14 days, 21 days, and 28 days), the tissue surrounding the intervention site is extracted, and assayed.

[0281] Devices comprising balloons having coatings disclosed herein alternatively are implanted in the common iliac arteries of New Zealand white rabbits. The balloons are expanded to a 1:1.1 balloon: artery ratio. At multiple time points, animals are euthanized (e.g., t=1 day, 7 days, 14 days, 21 days, and 28 days), the tissue surrounding the intervention site is extracted, and assayed.

Example 1

Cutting Balloons

[0282] Cutting Balloon (1)—Mechanical Stimulation to Free the Coating

[0283] A cutting balloon is coated comprising a polymer and an active agent. The coated cutting balloon is positioned at the intervention site. The balloon is inflated to at least 25% below its nominal inflation pressure. Upon deflation and removal of the cutting balloon from the intervention site, at least about 5% to at least about 30% of the coating is freed from the surface of the cutting balloon and is deposited at the intervention site.

[0284] In some examples, the balloon unfolds during inflation, causing mechanical shearing forces to at least augment transfer and/or freeing and/or deposition of the coating from the balloon to the intervention site.

[0285] In some examples, the balloon twists during inflation, causing mechanical shearing forces to at least augment transfer and/or freeing and/or deposition of the coating from the balloon.

[0286] In one example, the polymer of the coating is about 50:50 PLGA-Ester End Group, MW~191(D, degradation rate~1-2 months or about 50:50 PLGA-Carboxylate End Group, MW~101(D, degradation rate~28 days. The active agent is a pharmaceutical agent such as a macrolide immunosuppressive drug. Equipment and coating process similar to Example 1 is employed. The intervention site is a vascular lumen wall. Upon inflation of the cutting balloon, at least about 50% of the coating is freed from the device at the intervention site.

[0287] In another example, a cutting balloon is coated with a formulation of PLGA+sirolimus with total loading of sirolimus~20 µg with the coating preferentially on the wire of the cutting balloon. Equipment and process similar to Example 1 is employed. The intervention site is a coronary artery. Upon inflation of the cutting balloon, about 5% to about 15% of the coating is freed from the device resulting in delivery of ~2.0 µg of drug delivered to the artery.

[0288] In another example, the polymer of the coating is about 50:50 PLGA-Ester End Group, MW~191(D, degradation rate~1-2 months or about 50:50 PLGA-Carboxylate End Group, MW~101(D, degradation rate~28 days. The active agent is a chemotherapeutic agent. Equipment and coating process similar to Example 1 is employed. The intervention site is a cavity resulting from removal of a tumor. Upon inflation of the cutting balloon, at least about 75% of the coating is transferred from the device to the intervention site.

[0289] In-Vivo Testing:

[0290] A group of 27 New Zealand white rabbits is prepared for a Seldinger procedure using a cutting balloon coated with a formulation of about 50:50 PLGA-Ester End Group (MW~19 kD, degradation rate~1-2 months) and sirolimus with total loading of sirolimus~20 µg with the coating preferentially on the wire of the cutting balloon. The device is placed at a coronary artery intervention site with the assistance of fluoroscopy to aid in positioning the device at the same location in each subject. Six animals are subjected to the procedure using a coated balloon that does not have sirolimus in the coating. After deployment and removal of the device, 3 control animals are sacrificed at 1 hour post deployment and serum and tissue samples are collected. The 3 remaining control animals are sacrificed at 56 days post deployment. During the course of the study, serum samples are collected from control and drug-treated animals every five days. The drug treated animals, 3 each, are sacrificed at 1 hour, 24 hours, 7 days, 14 days, 28 days, 42 days and 56 days post deployment. A serum sample as well as a tissue sample from the deployment site is collected.

[0291] The tissue and serum samples may be subjected to analysis for sirolimus concentration. In order to determine the amount of coating freed from the device and/or delivered to the intervention site as a percent of the total amount of coating on the substrate, the tissue concentration of sirolimus at the one hour time point (or any time point within the first day following of the procedure) may be used along with the total content expected for the coating (based on the total content for the manufacturing lot) or along with the content of coating remaining on the device once removed and the percentage calculated. This percentage is correlative of the percent of coating freed, dissociated, and/or transferred from the device

and delivered to the intervention site. Alternatively, the tissue may be analyzed by various means (noted herein, including but not limited to SEM, TEM, and, where image enhanced polymers are used, various imaging means capable of detecting these enhanced polymers) to detect the percent of the coating freed, dissociated and/or transferred from the substrate and delivered to the intervention site. Again, the amount of coating known to be on the substrate based on manufacturing lot characteristics, and/or an assessment of the coating remaining on the device following removal of the device from the subject (for example, wherein the device is an angioplasty catheter and the substrate is the balloon of the catheter) may be used to determine the percent of coating freed, dissociated, and/or transferred from the device. In some instances, an assessment of the device following the procedure alone is sufficient to assess the amount freed or dissociated from the substrate, without determination of the amount delivered to the intervention site. Additionally, where a determination of improvement and/or disease treatment is desired, levels of proinflammatory markers could be tested to indicate improvement and/or treatment of a disease and/or ailment, for example, by testing high sensitive C-reactive protein (hsCRP), interleukin-6 (IL-6), interleukin-1β (IL-1β) and/or monocyte chemoattractant protein-1 (MCP-1). The release kinetics of the drug may be indicated by plotting the sirolimus concentrations at the timepoints noted above.

[0292] For embodiments using different drugs other than sirolimus, the biomarkers are selected based on the disease to be treated and the drugs administered during the course of therapy as determined by one of skill in the art. These biomarkers may be used to indicate the treatment results for each subject.

[0293] Other in-vivo tests described herein may be used instead of this test and/or in addition to this test, adjusted for the particularities of this device, as would be known to one of ordinary skill in the art.

[0294] In-Vitro Testing:

[0295] One sample of the coated cutting balloon prepared in example 1 is secured to a balloon catheter. A segment of optically clear TYGON® B-44-3 tubing with O.D.=0.125", I.D.=0.0625" (Available from McMaster-Carr Part Number: 5114K11 (www.mcmaster.com)) is filled with phosphate-buffered saline solution and immersed in a water bath at 37° C. to mimic physiological conditions of deployment into a subject. The coated balloon is inserted into the tubing and the balloon is inflated to at least 25% below the balloon's nominal pressure to mechanically transfer the coating from the balloon to the tubing wall. The balloon is deflated and removed from the tubing. Optical microscopy is performed on the tubing and/or the balloon (which is inflated to at least 25% below the balloon's nominal pressure, at least) to determine the presence and amount of coating transferred to the tubing and/or the amount of coating freed, dissociated, and/or transferred from the balloon. Other in-vitro tests described herein may be used instead of this test and/or in addition to this test, adjusted for the particularities of this device, as would be known to one of ordinary skill in the art.

[0296] Cutting Balloon (2)—Mechanical Stimulation to Free the Coating

[0297] A cutting balloon is coated using a solution-based system (spray or dip coating) comprising a polymer and an active agent. The coated cutting balloon is positioned at the intervention site. The balloon is inflated to at least 25% below its nominal inflation pressure. At least about 5% to at least

about 30% of the coating is freed from the surface of the cutting balloon and is deposited at the intervention site.

[0298] In some examples, the balloon unfolds during inflation, causing mechanical shearing forces to at least augment transfer and/or freeing and/or deposition of the coating from the balloon to the intervention site.

[0299] In some examples, the balloon twists during inflation, causing mechanical shearing forces to at least augment transfer and/or freeing and/or deposition of the coating from the balloon.

[0300] In one example, the polymer of the coating is about 50:50 PLGA-Ester End Group, MW~191(D, degradation rate~1-2 months or about 50:50 PLGA-Carboxylate End Group, MW~10 kD, degradation rate~28 days. The active agent is a pharmaceutical agent such as a macrolide immunosuppressive drug. Equipment and coating process using a spray and/or dip coating process is employed. The intervention site is a vascular lumen wall. Upon inflation of the cutting balloon, at least about 50% of the coating is freed from the device at the intervention site.

[0301] In another example, a cutting balloon is coated with a formulation of PLGA+sirolimus with total loading of sirolimus~20 µg with the coating preferentially on the wire of the cutting balloon. Equipment and coating process using a spray and/or dip coating process is employed. The intervention site is a coronary artery. Upon inflation of the cutting balloon, about 5% to about 15% of the coating is freed from the device resulting in delivery of ~2.0 µg of drug delivered to the artery.

[0302] In another example, the polymer of the coating is about 50:50 PLGA-Ester End Group, MW~19 kD, degradation rate~1-2 months or about 50:50 PLGA-Carboxylate End Group, MW~10 kD, degradation rate~28 days. The active agent is a chemotherapeutic agent. Equipment and coating process using a spray and/or dip coating process is employed. The intervention site is a cavity resulting from removal of a tumor. Upon inflation of the cutting balloon, at least about 75% of the coating is transferred from the device to the intervention site.

[0303] In-Vivo Testing:

[0304] A group of 27 New Zealand white rabbits is prepared for a Seldinger procedure using a cutting balloon coated with a formulation of about 50:50 PLGA-Ester End Group (MW~19 kD, degradation rate~1-2 months) and sirolimus with total loading of sirolimus~20 µg with the coating preferentially on the wire of the cutting balloon. The device is placed at a coronary artery intervention site with the assistance of fluoroscopy to aid in positioning the device at the same location in each subject. Six animals are subjected to the procedure using a coated balloon that does not have sirolimus in the coating. After deployment and removal of the device, 3 control animals are sacrificed at 1 hour post deployment and serum and tissue samples are collected. The 3 remaining control animals are sacrificed at 56 days post deployment. During the course of the study, serum samples are collected from control and drug-treated animals every five days. The drug treated animals, 3 each, are sacrificed at 1 hour, 24 hours, 7 days, 14 days, 28 days, 42 days and 56 days post deployment.

[0305] The tissue and serum samples may be subjected to analysis for sirolimus concentration. In order to determine the amount of coating freed from the device and/or delivered to the intervention site as a percent of the total amount of coating on the substrate, the tissue concentration of sirolimus at the one hour time point (or any time point within the first day

following of the procedure) may be used along with the total content expected for the coating (based on the total content for the manufacturing lot) or along with the content of coating remaining on the device once removed and the percentage calculated. This percentage is correlative of the percent of coating freed, dissociated, and/or transferred from the device and delivered to the intervention site. Alternatively, the tissue may be analyzed by various means (noted herein, including but not limited to SEM, TEM, and, where image enhanced polymers are used, various imaging means capable of detecting these enhanced polymers) to detect the percent of the coating freed, dissociated and/or transferred from the substrate and delivered to the intervention site. Again, the amount of coating known to be on the substrate based on manufacturing lot characteristics, and/or an assessment of the coating remaining on the device following removal of the device from the subject (for example, wherein the device is an angioplasty catheter and the substrate is the balloon of the catheter) may be used to determine the percent of coating freed, dissociated, and/or transferred from the device. In some instances, an assessment of the device following the procedure alone is sufficient to assess the amount freed or dissociated from the substrate, without determination of the amount delivered to the intervention site. Additionally, where a determination of improvement and/or disease treatment is desired, levels of proinflammatory markers could be tested to indicate improvement and/or treatment of a disease and/or ailment, for example, by testing high sensitive C-reactive protein (hsCRP), interleukin-6 (IL-6), interleukin-1β (IL-1β) and/or monocyte chemoattractant protein-1 (MCP-1). The release kinetics of the drug may be indicated by plotting the sirolimus concentrations at the timepoints noted above.

[0306] For embodiments using different drugs other than sirolimus, the biomarkers are selected based on the disease to be treated and the drugs administered during the course of therapy as determined by one of skill in the art. These biomarkers may be used to indicate the treatment results for each subject.

[0307] Other in-vivo tests described herein may be used instead of this test and/or in addition to this test, adjusted for the particularities of this device, as would be known to one of ordinary skill in the art.

[0308] In-Vitro Testing:

[0309] One sample of the coated cutting balloon prepared in using spray and/or dip coating process is secured to a balloon catheter. A segment of optically clear TYGON® B-44-3 tubing with O.D.=0.125", I.D.=0.0625" (Available from McMaster-Carr Part Number: 5114K11 (www.mcmaster.com)) is filled with phosphate-buffered saline solution and immersed in a water bath at 37° C. to mimic physiological conditions of deployment into a subject. The coated balloon is inserted into the tubing and the balloon is inflated to at least 25% below the balloon's nominal pressure to mechanically transfer the coating from the balloon to the tubing wall. The balloon is deflated and removed from the tubing. Optical microscopy is performed on the tubing and/or the balloon (which is inflated to at least 25% below the balloon's nominal pressure, at least) to determine the presence and amount of coating transferred to the tubing and/or the amount of coating freed, dissociated, and/or transferred from the balloon. Other in-vitro tests described herein may be used instead of this test and/or in addition to this test, adjusted for the particularities of this device, as would be known to one of ordinary skill in the art.

[0310] Cutting Balloon (3)—Mechanical Stimulation to Free the Coating

[0311] A cutting balloon is coated comprising a release agent, a polymer and an active agent. The coated cutting balloon is positioned at the intervention site. The balloon is inflated to at least 25% below its nominal inflation pressure. At least about 5% to at least about 50% of the coating is freed from the surface of the cutting balloon and is deposited at the intervention site.

[0312] In some examples, the balloon unfolds during inflation, causing mechanical shearing forces to at least augment transfer and/or freeing and/or deposition of the coating from the balloon to the intervention site.

[0313] In some examples, the balloon twists during inflation, causing mechanical shearing forces to at least augment transfer and/or freeing and/or deposition of the coating from the balloon.

[0314] In one example, the polymer of the coating is about 50:50 PLGA-Ester End Group, MW~191(D, degradation rate~1-2 months or about 50:50 PLGA-Carboxylate End Group, MW~10 kD, degradation rate~28 days. The active agent is a pharmaceutical agent such as a macrolide immunosuppressive drug. Equipment and coating process similar to Example 2 is employed. The intervention site is a vascular lumen wall. Upon inflation of the cutting balloon, at least about 50% of the coating is freed from the device at the intervention site.

[0315] In another example, a cutting balloon is coated with a formulation of PLGA+sirolimus with total loading of sirolimus~20 µg with the coating preferentially on the wire of the cutting balloon.

[0316] Equipment and process similar to Example 2 is employed. The intervention site is a coronary artery. The release agent is ePTFE powder. Upon inflation of the cutting balloon, about 5% to about 15% of the coating is freed from the device resulting in delivery of ~2.0 µg of drug delivered to the artery.

[0317] In another example, the polymer of the coating is about 50:50 PLGA-Ester End Group, MW~19 kD, degradation rate~1-2 months or about 50:50 PLGA-Carboxylate End Group, MW~10 kD, degradation rate~28 days. The active agent is a chemotherapeutic agent. Equipment and coating process similar to Example 2 is employed. The release agent a micronized active agent or another active agent in a micronized form. The intervention site is a cavity resulting from removal of a tumor. Upon inflation of the cutting balloon, at least about 75% of the coating is transferred from the device to the intervention site.

[0318] In-Vivo Testing:

[0319] A group of 27 New Zealand white rabbits is prepared for a Seldinger procedure using a cutting balloon coated with a formulation of about 50:50 PLGA-Ester End Group (MW~19 kD, degradation rate~1-2 months) and sirolimus with total loading of sirolimus~20 µg with the coating preferentially on the wire of the cutting balloon. The device is placed at a coronary artery intervention site with the assistance of fluoroscopy to aid in positioning the device at the same location in each subject. Six animals are subjected to the procedure using a coated balloon that does not have sirolimus in the coating. After deployment and removal of the device, 3 control animals are sacrificed at 1 hour post deployment and serum and tissue samples are collected. The 3 remaining control animals are sacrificed at 56 days post deployment. During the course of the study, serum samples are collected

from control and drug-treated animals every five days. The drug treated animals, 3 each, are sacrificed at 1 hour, 24 hours, 7 days, 14 days, 28 days, 42 days and 56 days post deployment. The tissue and serum samples may be subjected to analysis for sirolimus concentration.

[0320] In order to determine the amount of coating freed from the device and/or delivered to the intervention site as a percent of the total amount of coating on the substrate, the tissue concentration of sirolimus at the one hour time point (or any time point within the first day following of the procedure) may be used along with the total content expected for the coating (based on the total content for the manufacturing lot) or along with the content of coating remaining on the device once removed and the percentage calculated. This percentage is correlative of the percent of coating freed, dissociated, and/or transferred from the device and delivered to the intervention site. Alternatively, the tissue may be analyzed by various means (noted herein, including but not limited to SEM, TEM, and, where image enhanced polymers are used, various imaging means capable of detecting these enhanced polymers) to detect the percent of the coating freed, dissociated and/or transferred from the substrate and delivered to the intervention site. Again, the amount of coating known to be on the substrate based on manufacturing lot characteristics, and/or an assessment of the coating remaining on the device following removal of the device from the subject (for example, wherein the device is an angioplasty catheter and the substrate is the balloon of the catheter) may be used to determine the percent of coating freed, dissociated, and/or transferred from the device. In some instances, an assessment of the device following the procedure alone is sufficient to assess the amount freed or dissociated from the substrate, without determination of the amount delivered to the intervention site. Additionally, where a determination of improvement and/or disease treatment is desired, levels of proinflammatory markers could be tested to indicate improvement and/or treatment of a disease and/or ailment, for example, by testing high sensitive C-reactive protein (hsCRP), interleukin-6 (IL-6), interleukin-1β (IL-1β), and/or monocyte chemoattractant protein-1 (MCP-1). The release kinetics of the drug may be indicated by plotting the sirolimus concentrations at the timepoints noted above.

[0321] For embodiments using different drugs other than sirolimus, the biomarkers are selected based on the disease to be treated and the drugs administered during the course of therapy as determined by one of skill in the art. These biomarkers may be used to indicate the treatment results for each subject.

[0322] Other in-vivo tests described herein may be used instead of this test and/or in addition to this test, adjusted for the particularities of this device, as would be known to one of ordinary skill in the art.

[0323] In-Vitro Testing:

[0324] One sample of the coated cutting balloon prepared in Example 2 is secured to a balloon catheter. A segment of optically clear TYGON® B-44-3 tubing with O.D.=0.125", I.D.=0.0625" (Available from McMaster-Carr Part Number: 5114K11 (www.mcmaster.com)) is filled with phosphate-buffered saline solution and immersed in a water bath at 37° C. to mimic physiological conditions of deployment into a subject. The coated balloon is inserted into the tubing and the balloon is inflated to at least 25% below the balloon's nominal pressure to mechanically transfer the coating from the balloon to the tubing wall. The balloon is deflated and removed

from the tubing. Optical microscopy is performed on the tubing and/or the balloon (which is inflated to at least 25% below the balloon's nominal pressure, at least) to determine the presence and amount of coating transferred to the tubing and/or the amount of coating transferred from the balloon. Other in-vitro tests described herein may be used instead of this test and/or in addition to this test, adjusted for the particularities of this device, as would be known to one of ordinary skill in the art.

[0325] Cutting Balloon (4)—Mechanical Stimulation to Free the Coating

[0326] A cutting balloon is coated comprising a polymer and an active agent. The coated cutting balloon is positioned at the intervention site. The balloon is inflated to at least 25% below its nominal inflation pressure. At least about 10% to at least about 50% of the coating is freed from the surface of the cutting balloon and is deposited at the intervention site.

[0327] In some examples, the balloon unfolds during inflation, causing mechanical shearing forces to at least augment transfer and/or freeing and/or deposition of the coating from the balloon to the intervention site.

[0328] In some examples, the balloon twists during inflation, causing mechanical shearing forces to at least augment transfer and/or freeing and/or deposition of the coating from the balloon.

[0329] In one example, the polymer of the coating is about 50:50 PLGA-Ester End Group, MW~19 kD, degradation rate~1-2 months or about 50:50 PLGA-Carboxylate End Group, MW~10 kD, degradation rate~28 days. The active agent is a pharmaceutical agent such as a macrolide immunosuppressive drug. Equipment and coating process similar to Example 3 is employed. The intervention site is a vascular lumen wall. Upon inflation of the cutting balloon, at least about 50% of the coating is freed from the device at the intervention site.

[0330] In another example, a cutting balloon is coated with a formulation of PLGA+sirolimus with total loading of sirolimus~20 µg with the coating preferentially on the wire of the cutting balloon. Equipment and process similar to Example 3 is employed. The intervention site is a coronary artery. Upon inflation of the cutting balloon, about 5% to about 15% of the coating is freed from the device resulting in delivery of ~2.0 µg of drug delivered to the artery.

[0331] In another example, the polymer of the coating is about 50:50 PLGA-Ester End Group, MW~19 kD, degradation rate~1-2 months or about 50:50 PLGA-Carboxylate End Group, MW~10 kD, degradation rate~28 days. The active agent is a chemotherapeutic agent. Equipment and coating process similar to Example 3 is employed. The intervention site is a cavity resulting from removal of a tumor. Upon inflation of the cutting balloon, at least about 75% of the coating is transferred from the device to the intervention site.

[0332] In-Vivo Testing:

[0333] A group of 27 New Zealand white rabbits is prepared for a Seldinger procedure using a cutting balloon coated with a formulation of about 50:50 PLGA-Ester End Group (MW~19 kD, degradation rate~1-2 months) and sirolimus with total loading of sirolimus~20 µg with the coating preferentially on the wire of the cutting balloon. The device is placed at a coronary artery intervention site with the assistance of fluoroscopy to aid in positioning the device at the same location in each subject. Six animals are subjected to the procedure using a coated balloon that does not have sirolimus in the coating. After deployment and removal of the device, 3

control animals are sacrificed at 1 hour post deployment and serum and tissue samples are collected. The 3 remaining control animals are sacrificed at 56 days post deployment. During the course of the study, serum samples are collected from control and drug-treated animals every five days. The drug treated animals, 3 each, are sacrificed at 1 hour, 24 hours, 7 days, 14 days, 28 days, 42 days and 56 days post deployment.

[0334] The tissue and serum samples may be subjected to analysis for sirolimus concentration. In order to determine the amount of coating freed from the device and/or delivered to the intervention site as a percent of the total amount of coating on the substrate, the tissue concentration of sirolimus at the one hour time point (or any time point within the first day following of the procedure) may be used along with the total content expected for the coating (based on the total content for the manufacturing lot) or along with the content of coating remaining on the device once removed and the percentage calculated. This percentage is correlative of the percent of coating freed, dissociated, and/or transferred from the device and delivered to the intervention site. Alternatively, the tissue may be analyzed by various means (noted herein, including but not limited to SEM, TEM, and, where image enhanced polymers are used, various imaging means capable of detecting these enhanced polymers) to detect the percent of the coating freed, dissociated and/or transferred from the substrate and delivered to the intervention site. Again, the amount of coating known to be on the substrate based on manufacturing lot characteristics, and/or an assessment of the coating remaining on the device following removal of the device from the subject (for example, wherein the device is a cutting angioplasty catheter and the substrate is the cutting balloon of the catheter) may be used to determine the percent of coating freed, dissociated, and/or transferred from the device. In some instances, an assessment of the device following the procedure alone is sufficient to assess the amount freed or dissociated from the substrate, without determination of the amount delivered to the intervention site. Additionally, where a determination of improvement and/or disease treatment is desired, levels of proinflammatory markers could be tested to indicate improvement and/or treatment of a disease and/or ailment, for example, by testing high sensitive C-reactive protein (hsCRP), interleukin-6 (IL-6), interleukin-1β (IL-1β), and/or monocyte chemoattractant protein-1 (MCP-1). The release kinetics of the drug may be indicated by plotting the sirolimus concentrations at the timepoints noted above.

[0335] For embodiments using different drugs other than sirolimus, the biomarkers are selected based on the disease to be treated and the drugs administered during the course of therapy as determined by one of skill in the art. These biomarkers may be used to indicate the treatment results for each subject.

[0336] Other in-vivo tests described herein may be used instead of this test and/or in addition to this test, adjusted for the particularities of this device, as would be known to one of ordinary skill in the art.

[0337] In-Vitro Testing:

[0338] One sample of the coated cutting balloon prepared in Example 3 is secured to a balloon catheter. A segment of optically clear TYGON® B-44-3 tubing with O.D.=0.125", I.D.=0.0625" (Available from McMaster-Carr Part Number: 5114K11 (www.mcmaster.com)) is filled with phosphate-buffered saline solution and immersed in a water bath at 37° C. to mimic physiological conditions of deployment into a

subject. The coated balloon is inserted into the tubing and the balloon is inflated to at least 25% below the balloon's nominal pressure to mechanically transfer the coating from the balloon to the tubing wall. The balloon is deflated and removed from the tubing. Optical microscopy is performed on the tubing and/or the balloon (which is inflated to at least 25% below the balloon's nominal pressure, at least) to determine the presence and amount of coating transferred to the tubing and/or the amount of coating freed, dissociated, and/or transferred from the balloon. Other in-vitro tests described herein may be used instead of this test and/or in addition to this test, adjusted for the particularities of this device, as would be known to one of ordinary skill in the art.

[0339] Cutting Balloon (5)—Mechanical and Chemical Stimulation to Free the Coating

[0340] A cutting balloon is coated with a formulation comprising a base layer of methyl acrylate-methacrylic acid copolymer and additional layers of PLGA+paclitaxel with total dose of paclitaxel approx. 0.5 $\mu\text{g}/\text{mm}^2$ of the wire. The coating and sintering process is similar to that as described in Example 1. The balloon is constructed of a semipermeable polymer. The pressurization medium is pH 8 phosphate buffer. The coated cutting balloon is positioned at the intervention site. The balloon is pressurized to at least to at least 25% below its nominal inflation pressure. Upon pressurization of the cutting balloon in the diseased artery, at least about 10% to at least about 30% of the coating is released into the intervention site and upon depressurization and removal of the device, this material is deposited at the intervention site.

[0341] In some examples, the balloon unfolds during inflation, causing mechanical shearing forces to at least augment the pH mediated release of the coating from the balloon to the intervention site.

[0342] In some examples, the balloon twists during inflation, causing mechanical shearing forces to at least augment the pH mediated release of the coating from the balloon.

[0343] In one example, a base layer of methyl acrylate-methacrylic acid copolymer is formed and additional layers of the coating is about 50:50 PLGA-Ester End Group, MW~19 kD, degradation rate~1-2 months or about 50:50 PLGA-Carboxylate End Group, MW~10 kD, degradation rate~28 days. The active agent is a pharmaceutical agent such as a macrolide immunosuppressive drug. Equipment and coating process similar to Example 1 is employed. The balloon is constructed of a semipermeable polymer. The pressurization medium is pH 8 phosphate buffer. The intervention site is a vascular lumen wall. Upon inflation of the cutting balloon, at least about 50% of the coating is freed from the device at the intervention site.

[0344] In another example, a cutting balloon is coated with a base layer of methyl acrylate-methacrylic acid copolymer and additional layers of PLGA+sirolimus with total loading of sirolimus ~20 μ . Equipment and process similar to Example 1 is employed. The intervention site is a coronary artery. The balloon is constructed of a semipermeable polymer. The pressurization medium is pH 8 phosphate buffer. Upon inflation of the cutting balloon, about 5% to about 15% of the coating is freed from the device resulting in delivery of ~2.0 μg of drug delivered to the artery.

[0345] In another example, the polymer of the coating is about 50:50 PLGA-Ester End Group, MW~19 kD, degradation rate~1-2 months or about 50:50 PLGA-Carboxylate End Group, MW~10 kD, degradation rate~28 days. The active agent is a chemotherapeutic agent. Equipment and coating

process similar to Example 1 is employed. The intervention site is a cavity resulting from removal of a tumor. Upon inflation of the cutting balloon, at least about 75% of the coating is transferred from the device to the intervention site.

[0346] In-Vivo Testing:

[0347] A group of 27 New Zealand white rabbits is prepared for a Seldinger procedure using a cutting balloon coated with a formulation of about 50:50 PLGA-Ester End Group (MW~19 kD, degradation rate~1-2 months) and sirolimus with total loading of sirolimus~20 μg with the coating preferentially on the wire of the cutting balloon. The device is placed at a coronary artery intervention site with the assistance of fluoroscopy to aid in positioning the device at the same location in each subject. Six animals are subjected to the procedure using a coated balloon that does not have sirolimus in the coating. After deployment and removal of the device, 3 control animals are sacrificed at 1 hour post deployment and serum and tissue samples are collected. The 3 remaining control animals are sacrificed at 56 days post deployment. During the course of the study, serum samples are collected from control and drug-treated animals every five days. The drug treated animals, 3 each, are sacrificed at 1 hour, 24 hours, 7 days, 14 days, 28 days, 42 days and 56 days post deployment.

[0348] The tissue and serum samples may be subjected to analysis for sirolimus concentration. In order to determine the amount of coating freed from the device and/or delivered to the intervention site as a percent of the total amount of coating on the substrate, the tissue concentration of sirolimus at the one hour time point (or any time point within the first day following of the procedure) may be used along with the total content expected for the coating (based on the total content for the manufacturing lot) or along with the content of coating remaining on the device once removed and the percentage calculated. This percentage is correlative of the percent of coating freed, dissociated, and/or transferred from the device and delivered to the intervention site. Alternatively, the tissue may be analyzed by various means (noted herein, including but not limited to SEM, TEM, and, where image enhanced polymers are used, various imaging means capable of detecting these enhanced polymers) to detect the percent of the coating freed, dissociated and/or transferred from the substrate and delivered to the intervention site. Again, the amount of coating known to be on the substrate based on manufacturing lot characteristics, and/or an assessment of the coating remaining on the device following removal of the device from the subject (for example, wherein the device is an cutting angioplasty catheter and the substrate is the cutting balloon of the catheter) may be used to determine the percent of coating freed, dissociated, and/or transferred from the device. In some instances, an assessment of the device following the procedure alone is sufficient to assess the amount freed or dissociated from the substrate, without determination of the amount delivered to the intervention site. Additionally, where a determination of improvement and/or disease treatment is desired, levels of proinflammatory markers could be tested to indicate improvement and/or treatment of a disease and/or ailment, for example, by testing high sensitive C-reactive protein (hsCRP), interleukin-6 (IL-6), interleukin-1 β (IL-1 β), and/or monocyte chemoattractant protein-1 (MCP-1). The release kinetics of the drug may be indicated by plotting the sirolimus concentrations at the timepoints noted above.

[0349] For embodiments using different drugs other than sirolimus, the biomarkers are selected based on the disease to

be treated and the drugs administered during the course of therapy as determined by one of skill in the art. These biomarkers may be used to indicate the treatment results for each subject.

[0350] Other in-vivo tests described herein may be used instead of this test and/or in addition to this test, adjusted for the particularities of this device, as would be known to one of ordinary skill in the art.

[0351] In-Vitro Testing:

[0352] One sample of the coated cutting balloon prepared in Example 1 is secured to a balloon catheter. A segment of optically clear TYGON® B-44-3 tubing with O.D.=0.125", I.D.=0.0625" (Available from McMaster-Carr Part Number: 5114K11 (www.mcmaster.com)) is filled with phosphate-buffered saline solution and immersed in a water bath at 37° C. to mimic physiological conditions of deployment into a subject. The coated balloon is inserted into the tubing and the balloon is inflated to at least 25% below the balloon's nominal pressure to mechanically transfer the coating from the balloon to the tubing wall. The balloon is deflated and removed from the tubing. Optical microscopy is performed on the tubing and/or the balloon (which is inflated to at least 25% below the balloon's nominal pressure, at least) to determine the presence and amount of coating transferred to the tubing and/or the amount of coating freed, dissociated, and/or transferred from the balloon. Other in-vitro tests described herein may be used instead of this test and/or in addition to this test, adjusted for the particularities of this device, as would be known to one of ordinary skill in the art.

Example 2

Drug-Delivery Balloon Catheters Drug-Delivery Balloon (1)—Compliant Balloon

[0353] A compliant balloon is coated with a material comprising a polymer and an active agent. The coated compliant balloon is positioned at the intervention site. The balloon is inflated to at least 25% below its nominal inflation pressure. Upon deflation and removal of the compliant balloon from the intervention site, at least about 5% to at least about 30% of the coating is freed from the surface of the compliant balloon and is deposited at the intervention site.

[0354] In some examples, the balloon unfolds during inflation, causing mechanical shearing forces to at least augment transfer and/or freeing and/or deposition of the coating from the balloon to the intervention site.

[0355] In some examples, the balloon twists during inflation, causing mechanical shearing forces to at least augment transfer and/or freeing and/or deposition of the coating from the balloon.

[0356] In one example, the polymer of the coating is about 50:50 PLGA-Ester End Group, MW~19 kD, degradation rate~1-2 months or about 50:50 PLGA-Carboxylate End Group, MW~10 kD, degradation rate~28 days. The active agent is a pharmaceutical agent such as a macrolide immunosuppressive drug. Equipment and coating process similar to Example 1 is employed. The intervention site is a vascular lumen wall. Upon inflation of the compliant balloon, at least about 50% of the coating is freed from the device at the intervention site.

[0357] In another example, a compliant balloon is coated with a formulation of PLGA+sirolimus with total loading of sirolimus~20 µg. Equipment and process similar to Example 1 is employed. The intervention site is a coronary artery. Upon

inflation of the compliant balloon, about 5% to about 15% of the coating is freed from the device resulting in delivery of ~2.0 µg of drug delivered to the artery.

[0358] In another example, the polymer of the coating is 50:50 PLGA-Ester End Group, MW~19 kD, degradation rate~1-2 months or 50:50 PLGA-Carboxylate End Group, MW~10 kD, degradation rate~28 days. The active agent is a chemotherapeutic agent. Equipment and coating process similar to Example 1 is employed. The intervention site is a cavity resulting from removal of a tumor. Upon inflation of the compliant balloon, at least about 75% of the coating is transferred from the device to the intervention site.

[0359] In-Vivo Testing:

[0360] A group of 27 New Zealand white rabbits is prepared for a Seldinger procedure using a compliant balloon coated with a formulation of about 50:50 PLGA-Ester End Group (MW~19 kD, degradation rate~1-2 months) and sirolimus with total loading of sirolimus~20 µg. The device is placed at a coronary artery intervention site with the assistance of fluoroscopy to aid in positioning the device at the same location in each subject. Six animals are subjected to the procedure using a coated balloon that does not have sirolimus in the coating. After deployment and removal of the device, 3 control animals are sacrificed at 1 hour post deployment and serum and tissue samples are collected. The 3 remaining control animals are sacrificed at 56 days post deployment. During the course of the study, serum samples are collected from control and drug-treated animals every five days. The drug treated animals, 3 each, are sacrificed at 1 hour, 24 hours, 7 days, 14 days, 28 days, 42 days and 56 days post deployment. The tissue and serum samples may be subjected to analysis for sirolimus concentration.

[0361] In order to determine the amount of coating freed from the device and/or delivered to the intervention site as a percent of the total amount of coating on the substrate, the tissue concentration of sirolimus at the one hour time point (or any time point within the first day following of the procedure) may be used along with the total content expected for the coating (based on the total content for the manufacturing lot) or along with the content of coating remaining on the device once removed and the percentage calculated. This percentage is correlative of the percent of coating freed, dissociated, and/or transferred from the device and delivered to the intervention site. Alternatively, the tissue may be analyzed by various means (noted herein, including but not limited to SEM, TEM, and, where image enhanced polymers are used, various imaging means capable of detecting these enhanced polymers) to detect the percent of the coating freed, dissociated and/or transferred from the substrate and delivered to the intervention site. Again, the amount of coating known to be on the substrate based on manufacturing lot characteristics, and/or an assessment of the coating remaining on the device following removal of the device from the subject (for example, wherein the device is a cutting angioplasty catheter and the substrate is the balloon of the catheter) may be used to determine the percent of coating freed, dissociated, and/or transferred from the device. In some instances, an assessment of the device following the procedure alone is sufficient to assess the amount freed or dissociated from the substrate, without determination of the amount delivered to the intervention site. Additionally, where a determination of improvement and/or disease treatment is desired, levels of proinflammatory markers could be tested to indicate improvement and/or treatment of a disease and/or ailment, for example, by

testing high sensitive C-reactive protein (hsCRP), interleukin-6 (IL-6), interleukin-1 β (IL-1 β), and/or monocyte chemoattractant protein-1 (MCP-1). The release kinetics of the drug may be indicated by plotting the sirolimus concentrations at the timepoints noted above.

[0362] For embodiments using different drugs other than sirolimus, the biomarkers are selected based on the disease to be treated and the drugs administered during the course of therapy as determined by one of skill in the art. These biomarkers may be used to indicate the treatment results for each subject.

[0363] In-Vitro Testing:

[0364] One sample of the coated compliant balloon prepared in Example 1 is secured to a balloon catheter. A segment of optically clear TYGON® B-44-3 tubing with O.D.=0.125", I.D.=0.0625" (Available from McMaster-Carr Part Number: 5114K11 (www.mcmaster.com)) is filled with phosphate-buffered saline solution and immersed in a water bath at 37° C. to mimic physiological conditions of deployment into a subject. The coated balloon is inserted into the tubing and the balloon is inflated to at least 25% below the balloon's nominal pressure to mechanically transfer the coating from the balloon to the tubing wall. The balloon is deflated and removed from the tubing. Optical microscopy is performed on the tubing and/or the balloon (which is inflated to at least 25% below the balloon's nominal pressure, at least) to determine the presence and amount of coating transferred to the tubing and/or the amount of coating freed, dissociated, and/or transferred from the balloon.

[0365] Method for the Determination of Sirolimus Levels:

[0366] Media may be assayed for sirolimus content using HPLC. Calibration standards containing known amounts of drug are to determine the amount of drug eluted, or the content of a particular sample. The multiple peaks present for the sirolimus (also present in the calibration standards) are added to give the amount of drug eluted at that time period (in absolute amount and as a cumulative amount eluted) or as an amount of drug in a particular sample. HPLC analysis is performed using Waters HPLC system, set up and run on each sample as provided in the Table 1 below using an injection volume of 100 microl.

TABLE 1

Time point (minutes)	% Acetonitrile	% Ammonium Acetate (0.5%), pH 7.4	Flow Rate (mL/min)
0.00	10	90	1.2
1.00	10	90	1.2
12.5	95	5	1.2
13.5	100	0	1.2
14.0	100	0	3
16.0	100	0	3
17.0	10	90	2
20.0	10	90	0

[0367] In-Vitro Mass Loss Test:

[0368] One sample of the coated compliant balloon prepared in Example 1 is weighed on a microbalance and then secured to a balloon catheter. A segment of optically clear TYGON® B-44-3 tubing with O.D.=0.125", I.D.=0.0625" (Available from McMaster-Carr Part Number: 5114K11 (www.mcmaster.com)) is filled with phosphate-buffered saline solution and immersed in a water bath at 37° C. to mimic physiological conditions of deployment into a subject. The coated balloon is inserted into the tubing and the balloon

is inflated to at least 25% below the balloon's nominal pressure to mechanically transfer the coating from the balloon to the tubing wall. The balloon is deflated and removed from the tubing. After drying, the balloon is removed from the guidewire, further dried and weighed on a microbalance. Comparison of the pre- and post-deployment weights indicates how much coating is freed, dissociated, and/or transferred from the balloon. This analysis may instead and/or alternatively include testing of the tubing to determine the amount of coating freed, dissociated, and/or transferred from the device during this in-vitro test.

[0369] In-Vitro Coating Test:

[0370] One sample of the coated compliant balloon prepared in Example 1 is secured to a balloon catheter. A segment of optically clear TYGON® B-44-3 tubing with O.D.=0.125", I.D.=0.0625" (Available from McMaster-Carr Part Number: 5114K11 (www.mcmaster.com)) is filled with phosphate-buffered saline solution and immersed in a water bath at 37° C. to mimic physiological conditions of deployment into a subject. The coated balloon is inserted into the tubing and the balloon is inflated to at least 25% below the balloon's nominal pressure to mechanically transfer the coating from the balloon to the tubing wall. The balloon is deflated and removed from the tubing. The section of tubing exposed to the deployed balloon is cut away from the remainder of the tubing and the interior of the excised tubing rinsed with a small amount of ethanol and an amount of methylene chloride to make up 25 mL total volume of rinsings which are collected in a flask for analysis. Analysis by HPLC as described above is performed to determine the amount of material freed, dissociated, and/or transferred from the balloon. This analysis may instead and/or alternatively include testing of the substrate itself to determine the amount of coating freed, dissociated, and/or transferred from the device during this in-vitro test.

[0371] In-Vitro Testing:

[0372] One sample of the coated compliant balloon prepared in Example 1 is secured to a balloon catheter. A segment of resected coronary artery from Yucatan miniature swine is positionally fixed and filled with phosphate-buffered saline solution and immersed in a water bath at 37° C. to mimic physiological conditions of deployment into a subject. The coated balloon is inserted into the artery and the balloon is inflated to at least 25% below the balloon's nominal pressure to mechanically transfer the coating from the balloon to the arterial wall. The balloon is deflated and removed from the artery. The section of artery exposed to the deployed balloon is cut away from the remainder of the artery section, placed into a tissue homogenizer and the homogenized material is extracted with methylene chloride to make up 25 mL total volume of rinsings which are collected in a flask for analysis. Analysis by HPLC as described above is performed to determine the amount of material freed, dissociated, and/or transferred from the balloon. This analysis may instead and/or alternatively include testing of the substrate itself to determine the amount of coating freed, dissociated, and/or transferred from the device during this in-vitro test.

[0373] For embodiments related to non-vascular or non-luminal applications, e.g. a tumor site or other cavity or a cannulized site, the same technique is employed with the modification that the tissue to be assayed is resected from the tissue adjoining cavity receiving drug treatment.

[0374] In-Vitro Testing:

[0375] One sample of the coated compliant balloon prepared in Example 1 is secured to a balloon catheter. A segment of resected coronary artery from Yucatan miniature swine is positionally fixed and filled with phosphate-buffered saline solution and immersed in a water bath at 37° C. to mimic physiological conditions of deployment into a subject. The coated balloon is inserted into the artery and the balloon is inflated to at least 25% below the balloon's nominal pressure to mechanically transfer the coating from the balloon to the arterial wall. The balloon is deflated and removed from the artery. The section of artery exposed to the deployed balloon is cut away from the remainder of the artery section and incised lengthwise to lay open the artery. Optical microscopy is performed on the interior of artery to determine the presence and amount of coating transferred to the artery and/or the amount of coating transferred from the balloon. The tissue sample is also subjected to TEM-SEM analysis.

[0376] In-Vitro Testing of Release Kinetics:

[0377] One sample of the coated compliant balloon with total loading of sirolimus~20 µg prepared in Example 1 is secured to a balloon catheter. A flask containing exactly 25 mL of pH 7.4 aqueous phosphate buffer equilibrated to 37° C. equipped for magnetic stirring is prepared. Into this flask is placed the coated balloon and the catheter portion of the apparatus is secured such that the balloon does not touch the sides of the flask. The balloon is inflated to 120 psi with sterile water. Aliquots of 100 µL are removed prior to addition of the balloon, after placement of the balloon but prior to inflation of the balloon, and at regular time intervals of 2, 4, 6, 8, 10, 12, and 14 minutes. Upon removal of each aliquot an equivalent volume of aqueous buffer is added to maintain the volume at 25 mL. The aliquots are analyzed by HPLC as described above for the concentration of sirolimus.

[0378] In-Vitro Testing for Distal Flow Particulates:

[0379] One sample of the coated compliant balloon prepared in Example 1 is secured to a guidewire incorporating a porous filter of 100 micron pore size, such as the Cordis AngioGuard emboli capture guidewire. A segment of optically clear TYGON® B-44-3 tubing with O.D.=0.125", I.D.=0.0625" (Available from McMaster-Carr Part Number: 5114K11 (www.mcmaster.com)) is filled with phosphate-buffered saline solution and immersed in a water bath at 37° C. to mimic physiological conditions of deployment into a subject. The coated balloon is inserted into the tubing, the proximal end of the tubing surrounding the guidewire sealed with epoxy, and a hypodermic needle which is attached to an infusion pump and reservoir of 37° C. phosphate-buffered saline solution is inserted into the tubing proximal to the balloon assembly. The flow of saline is commenced, the distal filter is deployed and the balloon is inflated to at least 25% below the balloon's nominal pressure to mechanically transfer the coating from the balloon to the tubing wall. The balloon is deflated and removed from the tubing. The filter is deployed for 5 minutes after removal of the balloon, the flow of saline is halted, the tubing cut adjacent to the epoxy seal, the filter retracted and removed from the tubing. The content of the filter is analyzed.

[0380] In-Vitro Testing for Distal Flow Particulates:

[0381] One sample of the coated compliant balloon prepared in Example 1 is secured to a guidewire. A segment of optically clear TYGON® B-44-3 tubing with O.D.=0.125", I.D.=0.0625" (Available from McMaster-Carr Part Number: 5114K11 (www.mcmaster.com)) is filled with phosphate-

buffered saline solution and immersed in a water bath at 37° C. to mimic physiological conditions of deployment into a subject and the distal end of the tubing is connected to a turbidity light scattering detector as described in Analytical Ultracentrifugation of Polymers and Nanoparticles, W. Machtle and L. Borger, (Springer) 2006, p. 41. The coated balloon is inserted into the proximal end of the tubing, the proximal end of the tubing surrounding the guidewire sealed with epoxy, and a hypodermic needle which is attached to an infusion pump and reservoir of 37° C. phosphate-buffered saline solution is inserted into the tubing proximal to the balloon assembly. The flow of saline is commenced, a baseline for light transmission through the detector is established and the balloon is inflated to at least 25% below the balloon's nominal pressure to mechanically transfer the coating from the balloon to the tubing wall. The balloon is deflated and removed from the tubing. The flow is maintained for 10 minutes after removal of the balloon, and the flow is analyzed for the presence of particles based on detector response.

[0382] Drug-Delivery Balloon (2)—Non-Compliant Balloon

[0383] A non-compliant balloon is coated with a material comprising a polymer and an active agent. The coated non-compliant balloon is positioned at the intervention site. The balloon is inflated to at least 25% below its nominal inflation pressure. Upon deflation and removal of the non-compliant balloon from the intervention site, at least about 5% to at least about 30% of the coating is freed from the surface of the non-compliant balloon and is deposited at the intervention site.

[0384] In some examples, the balloon unfolds during inflation, causing mechanical shearing forces to at least augment transfer and/or freeing and/or deposition of the coating from the balloon to the intervention site.

[0385] In some examples, the balloon twists during inflation, causing mechanical shearing forces to at least augment transfer and/or freeing and/or deposition of the coating from the balloon.

[0386] In one example, the polymer of the coating is about 50:50 PLGA-Ester End Group, MW~19 kD, degradation rate~1-2 months or about 50:50 PLGA-Carboxylate End Group, MW~10 kD, degradation rate~28 days. The active agent is a pharmaceutical agent such as a macrolide immunosuppressive drug. Equipment and coating process similar to Example 1 is employed. The intervention site is a vascular lumen wall. Upon inflation of the non-compliant balloon, at least about 50% of the coating is freed from the device at the intervention site.

[0387] In another example, a non-compliant balloon is coated with a formulation of PLGA+sirolimus with total loading of sirolimus~20 µg. Equipment and process similar to Example 1 is employed. The intervention site is a coronary artery. Upon inflation of the non-compliant balloon, about 5% to about 15% of the coating is freed from the device resulting in delivery of ~2.0 µg of drug delivered to the artery.

[0388] In another example, the polymer of the coating is about 50:50 PLGA-Ester End Group, MW~19 kD, degradation rate~1-2 months or about 50:50 PLGA-Carboxylate End Group, MW~10 kD, degradation rate~28 days. The active agent is a chemotherapeutic agent. Equipment and coating process similar to Example 1 is employed. The intervention site is a cavity resulting from removal of a tumor. Upon

inflation of the non-compliant balloon, at least about 75% of the coating is transferred from the device to the intervention site.

[0389] In-vivo and/or in-vitro testing may be performed according to the methods described herein.

Example 3

In Vivo Delivery of Rapamycin from Coated Balloons

Sirolimus Coated Balloon Formulation Tested in Rabbits

[0390] GHOST Rapid Exchange (Rx) Catheter was used in this example. Ghost 3.0×18 mm Rx catheter balloons were coated and used in animal study. The study was conducted according to the following design. Several tests were run to determine in-vivo drug delivery characteristics of the rapamycin from the coated balloons.

[0391] The first test included expansion of the coated balloons in rabbit iliac arteries. 8 coated balloons were manufactured and tested in 4 rabbits. Four of the coated balloons were inflated in pre-dilated arteries (right iliac) for 60 seconds, and four of the coated balloons were inflated in non-dilated arteries (left iliac) for 60 seconds. The amount of drug (sirolimus) found in the arterial tissue at the site of expansion was determined. The following table indicates the results of the testing of these arteries for sirolimus concentration in arterial tissue and total amount of sirolimus in each artery. Drug coated balloons in right iliac arteries were inflated/deflated about 10-20 min before sacrifice. Drug coated balloons in left iliac arteries were inflated/deflated about 5-15 min before sacrifice.

Iliac Artery	Average Sirolimus (ng/mg)		Total Sirolimus per Artery (µg)	
	Average	SD	Average	SD
Right Iliac (denuded) (n = 4)	178.3	32.1	5.4	1.1
Left Iliac (uninjured) (n = 4)	216.1	122.4	3.9	1.7
Combined Right + Left Iliac Arteries (n = 8)	197.2	85.3	4.7	1.6

[0392] The following table indicates the raw data of the testing of these same arteries for the total amount of sirolimus in each artery. It also indicates a calculated transfer efficiency of sirolimus to the rabbit iliac arteries and the estimated time that the artery was exposed to blood flow. The percent (%) sirolimus transferred to the artery was calculated using an estimated total amount of sirolimus on the balloon. The estimated total amount of sirolimus on the balloon which was based on the batch average total amount of sirolimus coated on the same batch of balloons as the test sample balloon as determined by UV-Viscometric testing of the balloon. The estimated time that the artery was exposed to blood flow was the amount of time between balloon inflation and the balloon testing, and/or the time between balloon inflation and until the animal was sacrificed and the artery extracted for testing by HPLC for content of drug.

Rabbit #	Balloon #	Total Sirolimus per Artery (µg)	% Sirolimus Transferred to Artery	Estimated Time Artery Exposed to Blood Flow (min)	
#1	Right Iliac Artery	N185	5.0	7.76%	20
#1	Left Iliac Artery	N157	3.2	5.58%	15
#2	Right Iliac Artery	N164	7.0	12.62%	10
#2	Left Iliac Artery	N167	5.0	8.98%	5
#3	Right Iliac Artery	N175	5.1	9.17%	10
#3	Left Iliac Artery	N178	1.8	2.88%	5
#4	Right Iliac Artery	N191	4.5	7.59%	15
#4	Left Iliac Artery	N117	5.7	7.95%	10
	Tracking Average	—	4.7	7.8%	—
	SD	—	1.6	2.8%	—

[0393] The following table indicates the blood concentrations of sirolimus (whole blood) taken from the animals used in this test. A baseline concentration of sirolimus was taken prior to exposure to the coated balloon for each animal, that is, taken before balloon inflation. The whole blood samples were taken 5 to 15 minutes after the second balloon was inflated in each animal, since two coated balloons were delivered to each animal in this test. The results indicated in the table below, therefore, indicate the cumulative whole blood Sirolimus concentration from the inflation of 2 drug coated balloons per animal. The total sirolimus in blood is based on 56 mL of blood per kg (i.e. per kg weight of the rabbit tested).

Rabbit #	Extraction Conc. (ng/mL)	Est. Total Sirolimus in Blood (µg)
#1	Baseline	Below Quality Level
#2	Baseline	Below Quality Level
#3	Baseline	Below Quality Level
#4	Baseline	Below Quality Level
#1	(15 min)	11.4
#2	(5 min)	30.8
#3	(5 min)	22.2
#4	(10 min)	19.3
	Average (5-15 min)	20.9
	SD	8.0

[0394] The following table indicates the concentrations of sirolimus on each balloon used in this test following the test itself, to indicate the percent (%) of sirolimus lost following the test procedure. As noted above, each of the balloons was tracked to the respective artery, and inflated for 60 seconds (1 minute), then deflated and removed from the animal and tested for the percent of sirolimus remaining on the balloon. The percent (%) sirolimus lost is based on the amount of sirolimus remaining on the balloon following the test and the total amount of sirolimus coated on the balloon which is estimated from the balloon batch average as tested using UV-Viscometric methods. The variables which contribute to the amount (or percent) of sirolimus lost include the following: Balloon insertion into iliac (via jugular+aorta); Blood flow; Pleat/Fold/Sheath methods and procedures; ~10% lost during shipping; and/or Balloon inflation/contact with artery wall.

Balloon ID	Total Sirolimus per Balloon (μg)	% Sirolimus Lost
Rabbit #1 RIA Balloon N185	13.2	79.3%
Robbie #1 LIA Balloon N157	17.3	69.9%
Rabbit #2 RIA Balloon N164	4.8	91.5%
Rabbit #2 LIA Balloon N167	11.7	79.1%
Rabbit #3 RIA Balloon N175	16.0	71.4%
Rabbit #3 LIA Balloon N178	14.7	77.0%
Rabbit #4 RIA Balloon N191	9.6	83.6%
Rabbit #4 LIA Balloon N117	14.9	79.1%
Tracking Average	12.8	78.9%
SD	4.0	6.8%

[0395] In another test, tracking studies were conducted. The test comprises tracking 4 coated balloons to the aorta of a rabbit. Each of 4 coated balloons was inserted, tracked to the aorta of the rabbit, and left in the aorta for 2 minutes without inflating the balloon. Following insertion, tracking, and resting the balloon in the aorta for 2 minutes, the catheter including the coated balloon was removed from the animal.

[0396] The following table indicates the concentrations of sirolimus on each balloon used in this test following the test itself, to indicate the percent (%) of sirolimus lost following the test procedure. The percent (%) sirolimus lost is based on the amount of sirolimus remaining on the balloon following the test and the total amount of sirolimus coated on the balloon which is estimated from the balloon batch average as tested using UV-Viscometric methods. The variables which contribute to the amount (or percent) of sirolimus lost include the following: Balloon insertion into iliac (via jugular+aorta); Blood flow; Pleat/Fold/Sheath methods and procedures; and/or ~10% lost during shipping.

Balloon ID	Total Sirolimus per Balloon (μg)	% Sirolimus Lost
Tracking #1 Balloon (N120)	23.6	66.9%
Tracking #2 Balloon (N160)	20.8	63.9%
Tracking #3 Balloon (N166)	19.0	66.0%
Tracking #4 Balloon (N176)	22.0	65.5%
Tracking Average	21.3	65.6%
SD	2.0	1.3%

[0397] Sirolimus quantification was performed on the balloons and blood samples from the previous two tests (as indicated in the "Total Sirolimus per Balloon (μg)" columns of the previous two tables, and as indicated in the blood concentration table generally). That is, sirolimus content was determined from the 8 balloons inflated in rabbit iliac arteries, the 4 balloons tracked to but not inflated in rabbit aorta, and the 8 whole blood samples (2 samples/rabbit). The liver, kidney, spleens, hearts and lungs were stored (80° C.) for later drug analysis.

[0398] In summary, the tests performed in this Example indicate the following: 197.2 \pm 85.3 ng/mg of Sirolimus embedded in artery walls. The Efficiency of Sirolimus transferred from balloons to artery walls was 7.8 \pm 2.8%. The amount of sirolimus washed away into circulation was 5.4 \pm 2.3 μg . Following inflation in arteries, 78.9 \pm 6.8% of the sirolimus coated on the balloon was removed from the balloon. Prior to inflation in the arteries, 65.6 \pm 1.3% of the sirolimus coated on the balloon was removed from the balloon. For reference, 50-100 μg of sirolimus was coated on each balloon.

From 1% to 5% of the drug (sirolimus) was transferred to the artery. 1 ng of sirolimus per mg tissue was found during the testing as described in this example.

Example 4

In Vivo Delivery of Rapamycin from Coated Balloons

[0399] Binding agents may be incorporated into the coating to improve active agent retention in the artery. Example binding agents include cationic agents and/or positively charged molecules. An example binding agent may be a surfactant. Other agents may also and/or alternatively be used. Binding agents may include, for non-limiting example, at least one of: Polyarginine, Polyarginine 9-L-pArg, DEAE-Dextran (Diethylaminoethyl cellulose-Dextran), DMAB (Didodecyltrimethylammonium bromide), PEI (Polyethyleneimine), TAB (Tetradodecylammonium bromide), and DMTAB (Dimethylditetradecylammonium bromide). In some embodiments of the devices, coatings and/or methods provided herein the coating comprises a positive surface charge on a surface of the coating configured to contact the treatment site.

[0400] In some embodiments the surfactant comprises at least one of a primary amine having pH<10, and a secondary amine having pH<4. In some embodiments surfactant comprises octenidine dihydrochloride. In some embodiments the surfactant comprises a permanently charged quaternary ammonium cation. In some embodiments the permanently charged quaternary ammonium cation comprises at least one of: an Alkyltrimethylammonium salt such as cetyl trimethylammonium bromide (CTAB), hexadecyl trimethyl ammonium bromide, cetyl trimethylammonium chloride (CTAC); Cetylpyridinium chloride (CPC); Polyethoxylated tallow amine (POEA); Benzalkonium chloride (BAC); Benzethonium chloride (BZT); 5-Bromo-5-nitro-1,3-dioxane; Dimethyldioctadecylammonium chloride; and Dioctadecyldimethylammonium bromide (DODAB). In some embodiments the surfactant comprises at least one of: didodecyltrimethylammonium bromide (DMAB), linear isoform Polyethyleneimine (linear PEI), Branched Low MW Polyethyleneimine (PEI) (of about <25 KDa), Branched Low MW Polyethyleneimine (PEI) (of about <15 KDa), Branched Low MW Polyethyleneimine (PEI) (of about <10 KDa), Branched High MW Polyethyleneimine (of about \geq 25 KDa), Poly-L-Arginine (average or nominal MW of about 70,000 Da), Poly-L-Arginine (average or nominal MW > about 50,000 Da), Poly-L-Arginine (average or nominal MW of about 5,000 to about 15,000 Da), Poly-L-Lysine (average or nominal MW of about 28,200 Da), Poly-L-Lysine (average or nominal MW of about 67,000 Da), Poly Histidine, Ethylhexadecyldimethylammonium Bromide, Dodecyltrimethyl Ammonium Bromide, Tetradodecylammonium bromide, Dimethylditetradecyl Ammonium bromide, Tetrabutylammonium iodide, DEAE-Dextran hydrochloride, and Hexadimethrine Bromide. In some embodiments, the molecular weight of the binding agent is controlled. In some embodiments, the average size of the binding agent is controlled.

[0401] In some embodiments of the devices, coatings and/or methods provided herein the binding agent and the active agent are mixed and deposited together on the device. In some embodiments, the active agent and binding agent are lyophilized prior to deposition on the device. In some embodiments dry particles of the active agent and binding agent are generated in another manner familiar to one of skill in the art

and then coated on the balloon or other medical device as described herein, such as by an eSTAT coating process. In some embodiments of the devices, coatings and/or methods provided herein the surfactant is deposited on a balloon after the active agent is deposited thereon.

[0402] The positive surface charge of the coating may be about 20 mV to about 40 mV. The positive surface charge may be at least one of: at least about 1 mV, over about 1 mV, at least about 5 mV, at least about 10 mV, about 10 mV to about 50 mV, about 20 mV to about 50 mV, about 10 mV to about 40 mV, about 30 mV to about 40 mV, about 20 mV to about 30 mV, and about 25 mV to about 35 mV.

[0403] In some embodiments the average molecular weight of the binding agent is controlled. For example, Polyarginine may have an average molecular weight of 70 kDa, 5-15 kDa, another controlled molecular weight, or a combination thereof. In some embodiments the molecular weight of the binding agent is controlled. For example, in some embodiments, Polyarginine is the binding agent and at least 75% of the Polyarginine as is 70 kDa, 5-15 kDa, or another controlled molecular weight. In some embodiments, Polyarginine is the binding agent and at least 50% of the Polyarginine as is 70 kDa, 5-15 kDa, or another controlled molecular weight. In some embodiments, Polyarginine is the binding agent and at least 90% of the Polyarginine as is 70 kDa, 5-15 kDa, or another controlled molecular weight. In some embodiments, Polyarginine is the binding agent and at least 95% of the Polyarginine as is 70 kDa, 5-15 kDa, or another controlled molecular weight. In some embodiments, Polyarginine is the binding agent and at least 98% of the Polyarginine as is 70 kDa, 5-15 kDa, or another controlled molecular weight. In some embodiments, Polyarginine is the binding agent and at least 99% of the Polyarginine as is 70 kDa, 5-15 kDa, or another controlled molecular weight.

[0404] In some embodiments, the size of the active agent in the coating is controlled in order to improve drug retention in the artery. For non-limiting example, in the case of sirolimus as an active agent, the sirolimus may have an average size (mean diameter) of at least one of: 1.5 μm , 2.5 μm , 645 nm, 100-200 nm, another controlled size, or a combination thereof. In some embodiments, the active agent is sirolimus and wherein the sirolimus has a median size of at least one of: 1.5 μm , 2.5 μm , 645 nm, 100-200 nm, another controlled size, or a combination thereof. In some embodiments, the active agent is sirolimus and wherein the sirolimus has an average size (mean diameter) of at least one of: about 1.5 μm , about

2.5 μm , about 645 nm, about 100-200 nm, another controlled size, or a combination thereof. In some embodiments, the active agent is sirolimus and wherein the sirolimus has a median size of at least one of: about 1.5 μm , about 2.5 μm , about 645 nm, about 100-200 nm, another controlled size, or a combination thereof. In some embodiments the size of the active agent is controlled. For example, in some embodiments, sirolimus is the active agent and at least 75% of the sirolimus as is 1.5 μm , 2.5 μm , 645 nm, 100-200 nm, or another controlled size. In some embodiments, sirolimus is the active agent and at least 50% of the sirolimus as is 1.5 μm , 2.5 μm , 645 nm, 100-200 nm, or another controlled size. In some embodiments, sirolimus is the active agent and at least 90% of the sirolimus as is 1.5 μm , 2.5 μm , 645 nm, 100-200 nm, or another controlled size. In some embodiments, sirolimus is the active agent and at least 95% of the sirolimus as is 1.5 μm , 2.5 μm , 645 nm, 100-200 nm, or another controlled size. In some embodiments, sirolimus is the active agent and at least 98% of the sirolimus as is 1.5 μm , 2.5 μm , 645 nm, 100-200 nm, or another controlled size. In some embodiments, sirolimus is the active agent and at least 99% of the sirolimus as is 1.5 μm , 2.5 μm , 645 nm, 100-200 nm, or another controlled size. The active agent may be, on average, at least one of: at most 5 microns, over 1 micrometer, between 1 micrometer and 5 micrometers, about 1.5 micrometers on average, and about 2.5 micrometers on average.

[0405] In some embodiments, the ratio of the active agent to the binding agent is controlled. In some embodiments, the ratio of active agent to binding agent is 1:1, 1:2, 1:3, 1:4, 1:5, 1:10, 1:20, 2:1, 3:1, 4:1, 5:1, 10:1, 15:1, 20:1, 3:2, 2:3, 5:2, 5:3, 2:5, 3:5, or another controlled ratio.

[0406] In some embodiments, the coating may comprise nanoparticles, and the nanoparticles may comprise an active agent and a polymer.

[0407] Multiple coating formulations were coated on balloons 3.0 \times 18 or 3.0 \times 17 balloons of GHOST Rapid Exchange (Rx) Catheters and delivered in rabbits to their iliac arteries. The arterial tissue of the rabbits was extracted at certain time points up to 72 hours and the amount of drug found in the arterial tissue was determined by methods known to one of skill in the art, such as by HPLC methods testing the arterial tissue or by UV-Viscometric methods looking at loss of coating or agent during the procedure, expressed in ng drug (Sirolimus) per mg of tissue, indicated in the following table (sample size indicated therein).

Formulation Composition	5 minutes Sirolimus Concentration (ng/mg)	24 hours Sirolimus Concentration (ng/mg)	72 hours Sirolimus Concentration (ng/mg)
F1	127.9 \pm 80.2 (n = 20)	0.8 \pm 0.9 (n = 12)	N/A
F2	N/A	10.4 \pm 14.7 (n = 2)	N/A
F3	39.0 \pm 11.6 (n = 8)	25.2 \pm 20.2 (n = 10)	4.7 \pm 3.7 (n = 7)
F4	90.6 \pm 59.1 (n = 4)	1.3 \pm 1.9 (n = 2)	N/A
F5	6.6 \pm 2.1 (n = 4)	15.2 \pm 27.6 (n = 6)	BQL (n = 4)
F6	226.0 \pm 22.6 (n = 2)	5.4 \pm 7.6 (n = 2)	N/A
F7	97.2 \pm 54.7 (n = 4)	40.5 \pm 25.0 (n = 6)	2.7 \pm 1.7 (n = 4)
F8	N/A	BQL (n = 2)	N/A
F9	N/A	BQL (n = 2)	N/A
F10	100.5 \pm 17.6 (n = 4)	28.4 \pm 10.9 (n = 6)	10.2 \pm 5.6 (n = 4)
F11	92.4 \pm 18.9 (n = 4)	6.4 \pm 11.7 (n = 6)	3.9 \pm 5.7 (n = 4)
F12	N/A	BQL (n = 2)	N/A
F13A	N/A	BQL (n = 2)	N/A
F13B	74.2 \pm 13.1 (n = 4)	14.0 \pm 11.7 (n = 6)	0.9 \pm 1.7 (n = 4)

-continued

Formulation Composition	5 minutes Sirolimus Concentration (ng/mg)	24 hours Sirolimus Concentration (ng/mg)	72 hours Sirolimus Concentration (ng/mg)
F13C	N/A	BQL (n = 2)	N/A
F13D	N/A	53.0 ± 5.5 (n = 2)	N/A
F14A	N/A	BQL (n = 2)	N/A
F14B	N/A	BQL (n = 2)	N/A
F14C	Unable to make formulation		
F14D	N/A	BQL (n = 2)	N/A
F15	114.7 ± 66.2 (n = 4)	108.2 ± 119.8 (n = 4)	46.5 ± 46.1 (n = 4)
F16	73.7 ± 38.5 (n = 4)	N/A	BQL (n = 4)
F17	404.5 ± 96.0 (n = 4)	N/A	0.9 ± 1.1 (n = 4)
F18	191.3 ± 40.0 (n = 4)	N/A	1.4 ± 2.8 (n = 4)

[0408] The results were calculated as total amount of sirolimus extracted in the artery, as indicated in the following table:

Formulation Composition	5 minutes Sirolimus amount (µg)	24 hours Sirolimus amount (µg)	72 hours Sirolimus amount (µg)
F1	4.7 ± 1.6 (n = 8)	—	—
F1 (2 nd lot)	5.9 ± 1.6 (n = 12)	0.1 ± 0.1 (n = 12)	—
F2	—	0.4 ± 0.6 (n = 2)	—
F3	3.0 ± 1.5 (n = 6)	0.8 ± 0.5 (n = 8)	0.2 ± 0.1 (n = 6)
F3 (2 nd lot)	1.0 ± 0.4 (n = 2)	1.2 ± 1.6 (n = 2)	1.0 (n = 1)
F4	4.5 ± 3.2 (n = 4)	0.07 ± 0.1 (n = 2)	—
F5	0.4 ± 0.2 (n = 4)	0.6 ± 1.0 (n = 6)	BQL (n = 4)
F6	8.8 ± 1.2 (n = 2)	0.2 ± 0.2 (n = 2)	—
F7	6.2 ± 3.7 (n = 4)	2.1 ± 1.3 (n = 6)	0.2 ± 0.1 (n = 4)
F8	—	BQL (n = 2)	—
F9	—	BQL (n = 2)	—
F10	2.0 ± 0.4 (n = 4)	1.0 ± 0.8 (n = 6)	0.2 ± 0.1 (n = 4)
F11	2.3 ± 0.5 (n = 4)	0.3 ± 0.5 (n = 6)	0.1 ± 0.1 (n = 4)
F12	—	BQL (n = 2)	—
F13A	—	BQL (n = 2)	—
F13B	2.2 ± 0.4 (n = 4)	0.4 ± 0.3 (n = 6)	0.02 ± 0.03 (n = 4)
F13C	—	BQL (n = 2)	—
F13D	—	0.8 ± 0.2 (n = 2)	—
F14A	—	BQL (n = 2)	—
F14B	—	BQL (n = 2)	—
F14D	—	BQL (n = 2)	—
F15	4.8 ± 0.6 (n = 4)	2.0 ± 1.9 (n = 4)	1.2 ± 1.0 (n = 4)
F16	2.2 ± 0.8 (n = 4)	—	BQL (n = 4)
F17	9.4 ± 2.7 (n = 4)	—	0.02 ± 0.03 (n = 4)
F18	4.4 ± 0.9 (n = 4)	—	0.03 ± 0.07 (n = 4)

[0409] Certain formulations were selected for additional analysis, and their test results were normalized for the balloon length and the artery segment size extracted. The following results were found for these selected formulations:

Formulation Composition	5 minutes - Sirolimus Concentration (ng/mg)	24 hours - Sirolimus Concentration (ng/mg)	72 hours - Sirolimus Concentration (ng/mg)
F1	278.5 ± 112.2 (n = 20)	2.3 ± 2.6 (n = 12)	N/A
F3	97.1 ± 49.3 (n = 8)	60.1 ± 39.4 (n = 10)	11.9 ± 10.7 (n = 7)
F5	19.7 ± 6.4 (n = 4)	45.5 ± 82.9 (n = 6)	BQL (n = 4)
F7	291.5 ± 164.0 (n = 4)	121.5 ± 75.0 (n = 6)	8.0 ± 5.1 (n = 4)
F10	167.5 ± 29.4 (n = 4)	58.8 ± 33.3 (n = 6)	17.1 ± 9.3 (n = 4)
F11	153.9 ± 31.4 (n = 4)	17.1 ± 34.8 (n = 6)	6.5 ± 9.5 (n = 4)
F13B	130.9 ± 23.2 (n = 4)	24.7 ± 20.6 (n = 6)	1.5 ± 3.0 (n = 4)
F15	202.5 ± 116.8 (n = 4)	190.9 ± 211.5 (n = 4)	82.0 ± 81.3 (n = 4)
F16	130.0 ± 67.9 (n = 4)	N/A	BQL (n = 4)
F17	713.8 ± 169.5 (n = 4)	N/A	1.6 ± 1.9 (n = 4)
F18	337.5 ± 70.6 (n = 4)	N/A	2.5 ± 5.0 (n = 4)

[0410] In the rabbit arterial and blood tests noted in this example, the following coating details and formulations were used.

[0411] F1 (Formulation 1) comprised PLGA i.e. about 50:50 Lactic acid:Glycolic acid, and Sirolimus having an average size of 2.5 μm .

[0412] F2 (Formulation 2) comprised PLGA i.e. about 50:50 Lactic acid:Glycolic acid, and a 1:1 ratio of Sirolimus having an average size of 2.5 μm to Polyarginine 70 kDa.

[0413] F3 (Formulation 3) comprised PLGA i.e. about 50:50 Lactic acid:Glycolic acid, and a 10:1 ratio of Sirolimus having an average size of 1.5 μm or 2.5 μm to Polyarginine 70 kDa.

[0414] F4 (Formulation 4) comprised PLGA i.e. about 50:50 Lactic acid:Glycolic acid, and a 10:1 ratio of Sirolimus having an average size of 2.5 μm to DEAE-Dextran (Diethylaminoethyl cellulose-Dextran).

[0415] F5 (Formulation 5) comprised PLGA i.e. about 50:50 Lactic acid:Glycolic acid, and a 1:1 ratio of Sirolimus having an average size of 2.5 μm and DMAB (Didodecyldimethylammonium bromide).

[0416] F6 (Formulation 6) comprised PLGA i.e. about 50:50 Lactic acid:Glycolic acid, and a 10:1 ratio of Sirolimus having an average size of 2.5 μm and DMAB (Didodecyldimethylammonium bromide).

[0417] F7 (Formulation 7) comprised PLGA i.e. about 50:50 Lactic acid:Glycolic acid, and a 10:1 ratio of Sirolimus having an average size of 2.5 μm and PEI (Polyethyleneimine)

[0418] F8 (Formulation 8) comprised PLGA i.e. about 50:50 Lactic acid:Glycolic acid, and a 10:1 ratio of Sirolimus having an average size of 2.5 μm and TAB (Tetradodecylammonium bromide).

[0419] F9 (Formulation 9) comprised PLGA i.e. about 50:50 Lactic acid:Glycolic acid, and a 10:1 ratio of Sirolimus having an average size of 2.5 μm and DMTAB (Dimethylditetradecylammonium bromide).

[0420] F10 (Formulation 10) comprised PLGA i.e. about 50:50 Lactic acid:Glycolic acid, and a 1:1:1 ratio of Sirolimus having an average size of 2.5 μm to Polyarginine 70 kDa to PEI (Polyethyleneimine)

[0421] F11 (Formulation 11) comprised PLGA i.e. about 50:50 Lactic acid:Glycolic acid, and a 10:1:1 ratio of Sirolimus having an average size of 2.5 μm to TAB (Tetradodecylammonium bromide to DEAE-Dextran (Diethylaminoethyl cellulose-Dextran).

[0422] F12 (Formulation 12) comprised PLGA Nanospheres (130 nm) where the PLGA is 50:50 Lactic acid:Glycolic acid, and 6.3% Sirolimus.

[0423] F13A (Formulation 13A) comprised PLGA i.e. about 50:50 Lactic acid:Glycolic acid, and Sirolimus having an average size of 645 nm

[0424] F13B (Formulation 13B) comprised PLGA i.e. about 50:50 Lactic acid:Glycolic acid, and a 10:1 ratio of Sirolimus having an average size of 645 nm to Polyarginine 70 kDa.

[0425] F13C (Formulation 13C) comprised PLGA i.e. about 50:50 Lactic acid:Glycolic acid, and a 1:1 ratio of Sirolimus having an average size of 645 nm to DMAB (Didodecyldimethylammonium bromide).

[0426] F13D (Formulation 13D) comprised PLGA i.e. about 50:50 Lactic acid:Glycolic acid, and a 10:1 ratio of Sirolimus having an average size of 645 nm to PEI (Polyethyleneimine)

[0427] F14A (Formulation 14A) comprised PLGA i.e. about 50:50 Lactic acid:Glycolic acid, and Sirolimus having an average size of 100-200 nm.

[0428] F14B (Formulation 14B) comprised PLGA i.e. about 50:50 Lactic acid:Glycolic acid, and a 10:1 ratio of Sirolimus having an average size of 100-200 nm to Polyarginine 70 kDa.

[0429] F14C (Formulation 14C) comprised PLGA i.e. about 50:50 Lactic acid:Glycolic acid, and a 1:1 ratio of Sirolimus having an average size of 100-200 nm to DMAB (Didodecyldimethylammonium bromide). Note that this formulation was not able to be made, therefore, no animal study results were obtained.

[0430] F14D (Formulation 14D) comprised PLGA i.e. about 50:50 Lactic acid:Glycolic acid, and a 10:1 ratio of Sirolimus having an average size of 100-200 nm to PEI (Polyethyleneimine)

[0431] F15 (Formulation 15) comprised PLGA i.e. about 50:50 Lactic acid:Glycolic acid, and a 10:1 ratio of Sirolimus having an average size of 1.5 μm to Polyarginine 5-15 kDa.

[0432] F16 (Formulation 16) comprised PLGA i.e. about 50:50 Lactic acid:Glycolic acid, and a 10:1 ratio of Sirolimus having an average size of 1.5 μm to Polyarginine 9-L-pArg.

[0433] F17 (Formulation 17) comprised PLGA i.e. about 50:50 Lactic acid:Glycolic acid, and a 10:1 ratio of Sirolimus having an average size of 645 nm to Polyarginine 5-15 kDa.

[0434] F18 (Formulation 18) comprised PLGA i.e. about 50:50 Lactic acid:Glycolic acid, and a 10:1 ratio of Sirolimus having an average size of 645 nm to Polyarginine 9-L-pArg.

[0435] With the exception of F12, all methods comprised using an RESS process for coating the PLGA on the balloon, and using an eSTAT process for coating the Sirolimus and the positive charged molecule to the balloon. The general process for coating was 1) Polymer coat by RESS processes, 2) Sirolimus and binding agent coat (or sirolimus alone, if there was no binding agent used in the formulation e.g. 14A) by eSTAT processes, 3) sinter the coated balloon. The binding agent (i.e. charged particle, surfactant, and/or cationic particle) was part of the Sirolimus coating step wherein the balloon was coated with both the Sirolimus and the binding agent using an eSTAT process. Formulation 12 was coated on the balloon using only an eSTAT or an RESS process and a sinter step.

[0436] The sirolimus was mixed with the binding agent (e.g. the surfactant, the cationic particle, the charged molecule, for non-limiting example) if present in the particular formulation in the following manner. The process may be adapted to different binding agents and different active agents, however, it is described herein as used with respect to sirolimus and the binding agents which were surfactants in the formulations noted in this example. Lyophilisation or "freeze drying" processed produced a dry powder of associated drug and binding agent (e.g. surfactant) suitable for depositing onto balloons via the eSTAT method. Other processes familiar to one of skill in the art may be used as an alternative to lyophilisation in order to associate the drug and binding agent in a form suitable for deposition on the balloons

via a method described herein. In this example, rapamycin (sirolimus) was suspended in water with a binding agent to coat the sirolimus with binding agent. The well-suspended sirolimus and binding agent solution was frozen, retaining the sirolimus and binding agent assembly, and the water was removed by sublimation to produce the dry sirolimus and binding agent material.

[0437] A pre-lyophilisation set of steps may be used in the process of creating the dried sirolimus and binding agent solution for use in the eSTAT coating process. The solution created thereby may be used in a freeze dryer. The desired quantity of drug (e.g. sirolimus) and binding agent were weighed out into a 100 mL Schott bottle. Then 50 mL of water is added, in increments of 10 mL, to the Schott bottle. During each increment the solution is mixed with a stir rod to insure the sirolimus is being wetted. After the 50 mL is added the solution is sonicated in a bath sonicator (Branson 1510) for 1 hr. In the final pre-lyophilisation step, the well-suspended solution is carefully transferred to a 50 mL conical centrifuge tube using a plastic pipette; unsuspended sirolimus and/or binding agent particles (typically found floating on the surface of the suspension, are not transferred. Note: the efficiency of the sirolimus suspension by the binding agent affects the actual sirolimus to surfactant ratio of the transferred solution and the final recovered powder, often changing it from the initial sirolimus and binding agent ratio weighed out.

[0438] The Lyophilisation steps may be as follows: The recovered suspension in the 50 mL centrifuge tube is immersed in liquid nitrogen until the solution is completely frozen. Parafilm is used to cover the opening of the tube containing the frozen suspension, while perforations are made in the film to allow escape of the vapor phase water. The tube containing the frozen sample is loaded into a freeze dryer containment vessel and the vessel is attached to one of the freeze dryer stations. The switch above the nozzle for the loaded station is activated to begin the process. The lyophilisation step is complete when all of the frozen moisture is visibly absent from the tube. The sample, which may exist as a xerogel following lyophilisation, is easily converted to a free-flowing dry powder by shaking or stirring when the process is complete. It usually takes 1-2 days for a sample prepared as described above to complete the lyophilisation step. Note: the freeze-drier may need to be periodically be defrosted to remove the accumulated moisture from the samples in order to work effectively.

[0439] The following steps were taken to make the sirolimus and binding agent dry solution in the eSTAT coating process of the balloons (which had been pre-coated using an RESS process with PLGA as noted elsewhere herein). Measure out required quantities of sirolimus and binding agent into a 100 mL Schott bottle. Add 50 mL of water, in increments of 10 mL, to the Schott bottle. During each increment use a stir rod to mix the sirolimus and binding agent solution. After 50 mL of water is added, sonicate the solution for 1 hr. After sonication use a plastic pipette to transfer the suspended solution to a 50 mL centrifuge tube. Avoid transfer of any unsuspended sirolimus and binding agent particles. Place 50 mL conical tube (without lid) in liquid nitrogen until solution is completely frozen. Cover the top of the conical tube with parafilm and make holes in film for water to travel through. Seal the 50 mL conical bottle in the lyophilisation vessel and connect the vessel to a freeze dryer nozzle station. Turn

switch above the nozzle to evacuate the air from the vessel. Keep sample on the freeze-drier until all water has been removed (typically 1-2 days)

[0440] Rabbit Blood Concentration results follow. The amount of drug as a concentration per mL of blood was determined for several formulations, as indicated in the following table.

For- mulation	Sirolimus in whole blood (ng/mL)		
	5 min	24 hours	72 hours
F1	20.9 ± 8.0 (n = 4)	N/A	N/A
F1 (2 nd lot)	5.7 ± 1.6 (n = 6)	BQL (n = 6)	N/A
F2	N/A	BQL (n = 1)	N/A
F3	7.7 ± 3.7 (n = 3)	0.8 ± 0.7 (n = 4)	BQL (n = 3)
F3 (2 nd lot)	5.5 (n = 1)	BQL (n = 1)	BQL (n = 1)
F4	N/A	BQL (n = 1)	N/A
F5	0.99 ± 0.1 (n = 2)	BQL (n = 3)	BQL (n = 2)
F6	N/A	2.72 (n = 1)	N/A
F7	11.2 ± 3.4 (n = 2)	1.7 ± 0.3 (n = 3)	1.3 ± 0.9 (n = 2)
F8	N/A	BQL (n = 1)	N/A
F9	N/A	2.06 (n = 1)	N/A
F10	BQL (n = 2)	0.36 ± 0.6 (n = 3)	BQL (n = 2)
F11	10.1 ± 0.2 (n = 2)	BQL (n = 3)	BQL (n = 2)
F12	N/A	BQL (n = 1)	N/A
F13A	N/A	1.13 (n = 1)	N/A
F13B	6.4 ± 3.1 (n = 2)	1.0 ± 0.9 (n = 3)	BQL (n = 2)
F13C	N/A	BQL (n = 1)	N/A
F13D	N/A	2.99 (n = 1)	N/A
F14A	N/A	BQL (n = 1)	N/A
F14B	N/A	BQL (n = 1)	N/A
F14D	N/A	BQL (n = 1)	N/A
F15	5.7 ± 3.2 (n = 2)	1.8 ± 0.01 (n = 2)	BQL (n = 2)
F16	76.8 ± 89.4 (n = 2)	N/A	BQL (n = 2)
F17	25.6 ± 1.3 (n = 2)	N/A	BQL (n = 2)
F18	23.5 ± 3.3 (n = 2)	N/A	0.5 ± 0.8 (n = 2)

[0441] The amount of drug as a total amount found in the arterial tissue was determined for several formulations, as indicated in the following table.

For- mulation	Sirolimus in whole blood (µg)		
	5 min	24 hours	72 hours
F1	5.4 ± 2.3 (n = 4)	N/A	N/A
F1 (2 nd lot)	1.0 ± 0.3 (n = 6)	BQL (n = 6)	N/A
F2	N/A	BQL (n = 1)	N/A
F3	1.7 ± 0.6 (n = 3)	0.1 ± 0.1 (n = 4)	BQL (n = 3)
F3 (2 nd lot)	1.2 (n = 1)	BQL (n = 1)	BQL (n = 1)
F4	N/A	BQL (n = 1)	N/A
F5	0.18 ± 0.2 (n = 2)	BQL (n = 3)	BQL (n = 2)
F6	—	0.4 (n = 1)	N/A
F7	1.9 ± 0.6 (n = 2)	0.3 ± 0.1 (n = 3)	0.25 ± 0.01 (n = 2)
F8	N/A	BQL (n = 1)	N/A
F9	N/A	0.3 (n = 1)	N/A
F10	BQL (n = 2)	0.1 ± 0.1 (n = 3)	BQL (n = 2)
F11	2.0 ± 0.05 (n = 2)	BQL (n = 3)	BQL (n = 2)
F12	N/A	BQL (n = 1)	N/A
F13A	N/A	0.2 (n = 1)	N/A
F13B	1.3 ± 0.7 (n = 2)	0.2 ± 0.2 (n = 3)	BQL (n = 2)
F13C	N/A	BQL (n = 1)	N/A
F13D	N/A	0.6 (n = 1)	N/A
F14A	N/A	BQL (n = 1)	N/A
F14B	N/A	BQL (n = 1)	N/A
F14D	N/A	BQL (n = 1)	N/A

-continued

For-	Sirolimus in whole blood (μg)		
	5 min	24 hours	72 hours
F15	1.2 \pm 0.7 (n = 2)	0.4 \pm 0.0 (n = 2)	BQL (n = 2)
F16	18.7 \pm 21.9 (n = 2)	N/A	BQL (n = 2)
F17	6.2 \pm 0.3 (n = 2)	N/A	BQL (n = 2)
F18	5.5 \pm 0.6 (n = 2)	N/A	0.12 \pm 0.17 (n = 2)

[0442] The various formulations had the following average amount of sirolimus coated on each of the balloons tested in the rabbit arteries. These were average amounts of drug found on sample balloons coated according to the same procedures noted herein and from the same lots and batches as those tested in the rabbits as noted above.

Formulation	Sirolimus Coated on Balloons (μg)
F1	64.52 \pm 8.73
F1 (2 nd lot)	63.40 \pm 2.89
F2	41.05 \pm 7.17
F3	89.54 \pm 19.61
F3 (2 nd lot)	128.71 \pm 26.86

-continued

Formulation	Sirolimus Coated on Balloons (μg)
F13A	134.23 \pm 17.03
F13B	144.63 \pm 51.84
F13C	55.46 \pm 13.14
F13D	105.31 \pm 16.02
F14A	83.10 \pm 15.19
F14B	175.96 \pm 78.30
F14D	77.50 \pm 31.02
F15	106.53 \pm 22.55
F16	75.84 \pm 5.98
F17	197.64 \pm 15.89
F18	196.43 \pm 45.89

[0443] Following expansion of the balloons in the rabbit arteries, each of the balloons was removed from the animal and the residual sirolimus on each balloon was determined. Using the 5 minute data as an indication of the amount (and therefore percent) of sirolimus transferred to the artery, and using the amount of drug remaining on the balloon following the procedure, and using the average amount of drug on balloons of the same batch as an estimate of the total amount of drug on the original device (see the previous table), the percent of sirolimus transferred to the rabbit artery and the total percent of sirolimus released during the entire procedure was determined. The following table summarizes the results from the formulations tested in this manner

Formulation	Sirolimus on Balloon Post-Deployment (μg)	% Sirolimus Transferred to Artery (5 min) From Sirolimus Released off Respective Balloon	
		% Sirolimus Released	% Sirolimus Released
F1	12.8 \pm 4.0 (n = 8)	9.8 \pm 3.1% (n = 8)	78.9 \pm 6.8% (n = 8)
F1 (2 nd lot)	45.7 \pm 7.3 (n = 36)	23.0 \pm 8.5% (n = 12)	35.9 \pm 10.2% (n = 36)
F2	6.1 \pm 2.7 (n = 2)	N/A	85.1 \pm 3.6% (n = 2)
F3	27.6 \pm 9.1 (n = 20)	4.8 \pm 1.4% (n = 6)	68.4 \pm 15.4% (n = 20)
F3 (2 nd lot)	56.8 \pm 15.6 (n = 6)	1.2 \pm 0.6% (n = 2)	59.0 \pm 8.6% (n = 6)
F4	16.0 \pm 2.9 (n = 6)	5.1 \pm 3.5% (n = 4)	84.9 \pm 2.5% (n = 6)
F5	5.0 \pm 2.7 (n = 14)	0.6 \pm 0.2% (n = 4)	92.8 \pm 3.7% (n = 14)
F6	49.4 \pm 6.9 (n = 4)	3.5 \pm 0.2% (n = 2)	84.4 \pm 3.7% (n = 4)
F7	7.1 \pm 3.0 (n = 14)	3.9 \pm 2.4% (n = 4)	95.7 \pm 1.7% (n = 14)
F8	20.5 \pm 0.1 (n = 2)	N/A	78.1 \pm 3.8% (n = 2)
F9	37.0 \pm 4.1 (n = 2)	N/A	82.6 \pm 0.3% (n = 2)
F10	1.4 \pm 0.8 (n = 14)	4.0 \pm 0.3% (n = 4)	98.1 \pm 0.8% (n = 14)
F11	43.6 \pm 11.2 (n = 14)	1.7 \pm 0.4% (n = 4)	74.4 \pm 6.9% (n = 14)
F12	2.3 \pm 0.8 (n = 2)	N/A	97.1 \pm 1.0% (n = 2)
F13A	21.6 \pm 1.0 (n = 2)	N/A	85.0 \pm 0.8% (n = 2)
F13B	30.4 \pm 7.4 (n = 14)	3.8 \pm 0.6% (n = 4)	76.5 \pm 7.2% (n = 14)
F13C	2.1 \pm 0.1 (n = 2)	N/A	96.6 \pm 0.0% (n = 2)
F13D	9.2 \pm 2.6 (n = 2)	N/A	92.1 \pm 2.3% (n = 2)
F14A	11.6 \pm 0.8 (n = 2)	N/A	87.5 \pm 0.3% (n = 2)
F14B	16.4 \pm 0.6 (n = 2)	N/A	91.9 \pm 0.8% (n = 2)
F14D	1.7 \pm 0.1 (n = 2)	N/A	98.5 \pm 0.1% (n = 2)
F15	24.9 \pm 5.6 (n = 12)	5.3 \pm 0.7% (n = 4)	76.4 \pm 6.3% (n = 12)
F16	21.4 \pm 3.9 (n = 12)	4.2 \pm 1.6% (n = 4)	72.0 \pm 4.6% (n = 12)
F17	49.3 \pm 6.9 (n = 12)	6.6 \pm 1.9% (n = 4)	74.6 \pm 3.6% (n = 12)
F18	44.5 \pm 8.7 (n = 12)	2.5 \pm 0.8% (n = 4)	76.4 \pm 3.3% (n = 12)

-continued

Formulation	Sirolimus Coated on Balloons (μg)
F4	115.12 \pm 16.92
F5	68.49 \pm 4.73
F6	316.95 \pm 82.66
F7	165.25 \pm 17.47
F8	97.19 \pm 16.46
F9	218.86 \pm 26.73
F10	65.38 \pm 24.45
F11	170.66 \pm 14.30
F12	74.20 \pm 15.77

[0444] The following summary observations may be made with regard to the Rabbit arterial and blood testing noted in this Example. Formulation 15 has the most drug retention at 72 hours of any other formulation. Formulation 3 had a sirolimus retention of 3.9 \pm 3.4 ng/mg at 72 hours (both lots combined), and 3.2% of the drug released from the balloons (both lots combined) was retained in the artery five minutes after expansion of the balloon in the artery. Formulation 13B had a sirolimus retention of 0.9 \pm 1.7 ng/mg at 72 hours, and 3.8% of the drug released from the balloons was retained in the artery five minutes after expansion of the balloon in the

artery. Formulation 15 had a sirolimus retention of 46.5+/-46.1 ng/mg at 72 hours, and 5.3% of the drug released from the balloons was retained in the artery five minutes after expansion of the balloon in the artery.

[0445] In some embodiments of the methods, coatings, or devices provided herein, the coating comprises a 10:1 ratio of the active agent to the binding agent, wherein the active agent comprises sirolimus wherein the binding agent comprises Polyarginine. In some embodiments, the sirolimus has an average size of 1.5 μm or 2.5 μm . In some embodiments, the Polyarginine average molecular weight is 70 kDa. In some embodiments, the Polyarginine average molecular weight is 5-15 kDa. In some embodiments, the active agent and the binding agent are deposited on the balloon together using an eSTAT coating process. In some embodiments, the active agent and the binding agent are lyophilized prior to deposition on the balloon. In some embodiments, at least about 2 ng/mg of active agent are found in arterial tissue 72 hours after inflation of the balloon in the artery. In some embodiments, at least about 3 ng/mg of active agent are found in arterial tissue 72 hours after inflation of the balloon in the artery. In some embodiments, at least about 5 ng/mg of active agent are found in arterial tissue 72 hours after inflation of the balloon in the artery. In some embodiments, at least about 10 ng/mg of active agent are found in arterial tissue 72 hours after inflation of the balloon in the artery. In some embodiments, at least about 20 ng/mg of active agent are found in arterial tissue 72 hours after inflation of the balloon in the artery. In some embodiments, at least about 30 ng/mg of active agent are found in arterial tissue 72 hours after inflation of the balloon in the artery. In some embodiments, at least about 40 ng/mg of active agent are found in arterial tissue 72 hours after inflation of the balloon in the artery.

[0446] In some embodiments of the methods, coatings, or devices provided herein, in vivo measurement comprises inflating the balloon inside the artery of a porcine for about 1 minute and wherein the amount of active agent transferred to the artery is measured by UV-Vis evaluation of the coating remaining on the balloon as determined about five minutes after inflation of the balloon in the artery. In some embodiments of the methods, coatings, or devices provided herein, in vivo measurement comprises inflating the balloon inside the artery of a porcine for about 1 minute and wherein the amount of active agent transferred to the artery is measured by extracting the artery about five minutes after inflation of the balloon in the artery and determining the amount of drug in the extracted artery using standard methods described herein and/or known to one of skill in the art. In some embodiments of the methods, coatings, or devices provided herein, in vivo measurement comprises inflating the balloon inside the artery of a rabbit for about 1 minute and wherein the amount of active agent transferred to the artery is measured by UV-Vis evaluation of the coating remaining on the balloon as determined about five minutes after inflation of the balloon in the artery. In some embodiments of the methods, coatings, or devices provided herein, in vivo measurement comprises inflating the balloon inside the artery of a rabbit for about 1 minute and wherein the amount of active agent transferred to the artery is measured by extracting the artery about five minutes after inflation of the balloon in the artery and determining the amount of drug in the extracted artery using standard methods described herein and/or known to one of skill in the art.

[0447] Provided herein is a method of forming a coating on a medical device comprising depositing a polymer on the medical device using an RESS process, mixing a binding agent and active agent to create an active agent-binding agent mixture, lyophilizing the active agent-binding agent mixture and depositing the active agent-binding agent mixture on the medical device using an eSTAT process. In some embodiments, the binding agent comprises a surfactant.

[0448] Pharmacokinetic Studies in Porcine models:

[0449] Formulation 3 (F3) was coated on balloons of 3.0x17 Ghost Rapid Exchange (Rx) Catheters according to the procedures noted above and delivered in porcine to their coronary and mammary arteries. The animals were sacrificed and arterial tissue was extracted at several time points. The amount of drug found in the coronary arterial tissue was determined and is expressed in ng drug (Sirolimus) per mg of tissue, and is expressed in normalized form, i.e. normalized per mg of tissue and expressed in micrograms (μg) in the following table.

Time Point	Arterial Sirolimus Concentration (ng/mg)	SD	Total Sirolimus per Artery (μg)	SD
Day 1: Coronary (n = 5)	5.528	4.806	0.3647	0.3056
Day 3: Coronary (n = 6)	2.559	2.927	0.1436	0.1402
Day 7: Coronary (n = 5)	1.141	1.324	0.0948	0.1375
Day 14: Coronary (n = 5)	0.764	0.858	0.0645	0.0940
Day 30: Coronary (n = 5)	0.038	0.085	0.0013	0.0029

[0450] The amount of drug found in the mammary arterial tissue was determined and is expressed in ng drug (Sirolimus) per mg of tissue, and is expressed in normalized form, i.e. normalized per mg of tissue and expressed in micrograms (μg) in the following table.

Time Point	Arterial Sirolimus Concentration (ng/mg)	SD	Total Sirolimus per Artery (μg)	SD
Day 1: Mammary (n = 5)	2.722	2.931	0.1303	0.1285
Day 3: Mammary (n = 4)	0.243	0.386	0.0129	0.0200
Day 7: Mammary (n = 9)	0.277	0.648	0.0100	0.0225
Day 14: Mammary (n = 4)	0.105	0.066	0.0058	0.0037
Day 30: Mammary (n = 9)	0.030	0.090	0.0014	0.0043

[0451] A comparison was performed between arterial drug retention in a rabbit versus the porcine model, using the F3 formulation as described above. The comparison indicated that at Day 1, the Rabbit Iliac artery concentration of sirolimus was 25.20+/-20.20 in ng sirolimus per mg tissue, or 0.901 μg +/-0.684 μg when normalized by the amount of tissue in the sample (n=7-10). At the same time point at Day 1, the Porcine Coronary artery concentration of sirolimus was 5.528+/-4.806 in ng sirolimus per mg tissue, or 0.365 μg +/-0.306 μg when normalized by the amount of tissue in the sample (n=5-6). At Day 3, the rabbit iliac artery concentration of sirolimus was 4.66+/-3.65 in ng sirolimus per mg tissue, or 0.319 μg +/-0.338 μg when normalized by the amount of tissue in the sample. At the same time point at Day 3, the porcine coronary artery concentration of sirolimus was

2.559+/-2.927 in ng sirolimus per mg tissue, or 0.144 mg+/-0.144 mg when normalized by the amount of tissue in the sample.

[0452] Several formulations that were selected for 72-hour testing in the rabbit iliac model were submitted for elution testing using a standard elution method. FIG. 1 indicates the Average percent Sirolimus Eluted from the balloons at various time points for Formulations F3, F5, and F7. At time 0 days, the F5 is the highest percent elution at about 60%, and the F3 elution is the next highest data point at about 45% elution at 0 days, whereas F7 is the lowest line throughout all time points, at about 30% eluted at 0 days. The line for F5 is the top line of the graph, eluting the fastest of the three formulations indicated in the graph, whereas F3 is the middle line of the graph, and F7 eluting the slowest only reaching 100% elution at about day 13.

[0453] The coating may release the active agent into a treatment site over at least one of: about 3 days, about 5 days, about 1 week, about 1.5 weeks, about 2 weeks, about 14 days, about 3 weeks, about 21 days, about 4 weeks, about 28 days, about 1 month, about 1.5 months, about 2 months, at least about 3 days, at least about 5 days, at least about 1 week, at least about 1.5 weeks, at least about 2 weeks, at least about 14 days, at least about 3 weeks, at least about 21 days, at least about 4 weeks, at least about 28 days, at least about 1 month, at least about 1.5 months, at least about 2 months, about 7 to about 14 days, about 14 to about 21 days, about 14 to about 28 days, about 21 to about 28 days, and about 7 to about 28 days.

[0454] Provided herein is a coated medical device comprising: a medical device for delivering encapsulated active agent to a treatment site; and a coating on the medical device comprising the encapsulated active agent wherein the encapsulated active agent comprise active agent encapsulated in a polymer, and wherein the encapsulated active agent has a positive surface charge.

[0455] Provided herein is a coated medical device comprising: a medical device for delivering encapsulated active agent to a treatment site; and a coating on the medical device comprising the encapsulated active agent wherein the encapsulated active agent comprise a polymer that encapsulates at least a portion of an active agent, and wherein the encapsulated active agent has a positive surface charge.

[0456] In some embodiments, the active agent is not completely encapsulated. An active agent (or a portion thereof) need not be completely surrounded in order to be encapsulated by the polymer. In some embodiments, at least 10% of the surface area of the active agent is encapsulated in the polymer. In some embodiments, at least 20% of the surface area of the active agent is encapsulated in the polymer. In some embodiments, at least 25% of the surface area of the active agent is encapsulated in the polymer. In some embodiments, at least 30% of the surface area of the active agent is encapsulated in the polymer. In some embodiments, at least 40% of the surface area of the active agent is encapsulated in the polymer. In some embodiments, at least 50% of the surface area of the active agent is encapsulated in the polymer. In some embodiments, at least 60% of the surface area of the active agent is encapsulated in the polymer. In some embodiments, at least 70% of the surface area of the active agent is encapsulated in the polymer. In some embodiments, at least 75% of the surface area of the active agent is encapsulated in the polymer. In some embodiments, at least 80% of the surface area of the active agent is encapsulated in the polymer. In some embodiments, at least 90% of the surface area of the

active agent is encapsulated in the polymer. In some embodiments, at least 95% of the surface area of the active agent is encapsulated in the polymer. In some embodiments, at least one of: at least 5% of the surface area of the active agent is at least partially surrounded by the polymer, at least 10% of the surface area of the active agent is at least partially surrounded by the polymer, at least 15% of the surface area of the active agent is at least partially surrounded by the polymer, at least 20% of the surface area of the active agent is at least partially surrounded by the polymer, at least 25% of the surface area of the active agent is at least partially surrounded by the polymer, at least 30% of the surface area of the active agent is at least partially surrounded by the polymer, at least 40% of the surface area of the active agent is at least partially surrounded by the polymer, at least 50% of the surface area of the active agent is at least partially surrounded by the polymer, at least 60% of the surface area of the active agent is at least partially surrounded by the polymer, at least 70% of the surface area of the active agent is at least partially surrounded by the polymer, at least 75% of the surface area of the active agent is at least partially surrounded by the polymer, at least 80% of the surface area of the active agent is at least partially surrounded by the polymer, at least 90% of the surface area of the active agent is at least partially surrounded by the polymer, and at least 95% of the surface area of the active agent is at least partially surrounded by the polymer.

[0457] Provided herein is a coating for a medical device comprising encapsulated active agent comprising active agent encapsulated in a polymer, wherein the encapsulated active agent has a positive surface charge, and wherein the coating delivers active agent to a treatment site over at least about 1 day.

[0458] Provided herein is a method of forming a coating on a medical device comprising providing encapsulated active agent comprising a polymer and active agent, wherein the encapsulated active agent have a positive surface charge, depositing the encapsulated active agent on the medical device. In some embodiments, the coating delivers the active agent to the treatment site over at least about 1 day.

[0459] Provided herein is a method of forming a coating on a medical device comprising providing encapsulated active agent comprising a polymer at least partially encapsulating at least a portion of an active agent wherein the encapsulated active agent has a positive surface charge, and depositing the encapsulated active agent on the medical device. In some embodiments, the coating delivers the active agent to the treatment site over at least about 1 day.

[0460] Provided herein is a coated medical device comprising: a medical device for delivering an active agent to a treatment site; and a coating on the device comprising the active agent, wherein the coated medical device delivers at least a portion of the coating to the treatment site which portion releases active agent into the treatment site over at least about 1 day.

[0461] Provided herein is a coating for a medical device comprising an active agent, wherein the coating delivers the into a treatment site over at least about 1 day.

[0462] Provided herein is a method of forming coating on a medical device with of an active agent comprising depositing the active agent on the medical device using an eSTAT process.

[0463] In some embodiments of the devices, coatings and/or methods provided herein the polymer comprises PLGA. The PLGA may have at least one of: a MW of about 30 KDa

and a Mn of about 15 KDa, a Mn of about 10 KDa to about 25 KDa, and a MW of about 15 KDa to about 40 KDa.

[0464] In some embodiments of the methods and/or devices provided herein, the coating comprises a bioabsorbable polymer. In some embodiments, the active agent comprises a bioabsorbable polymer. In some embodiments, the bioabsorbable polymer comprises at least one of: Polylactides (PLA); PLGA (poly(lactide-co-glycolide)); Poly-anhydrides; Polyorthoesters; Poly(N-(2-hydroxypropyl)methacrylamide); DLPLA—poly(dl-lactide); LPLA—poly(l-lactide); PGA—polyglycolide; PDO—poly(dioxanone); PGA-TMC—poly(glycolide-co-trimethylene carbonate); PGA-LPLA—poly(l-lactide-co-glycolide); PGA-DLPLA—poly(dl-lactide-co-glycolide); LPLA-DLPLA—poly(l-lactide-co-dl-lactide); and PDO-PGA-TMC—poly(glycolide-co-trimethylene carbonate-co-dioxanone), and combinations, copolymers, and derivatives thereof. In some embodiments, the bioabsorbable polymer comprises between 1% and 95% glycolic acid content PLGA-based polymer.

[0465] In some embodiments of the methods and/or devices provided herein, the polymer comprises at least one of polycarboxylic acids, cellulosic polymers, proteins, polypeptides, polyvinylpyrrolidone, maleic anhydride polymers, polyamides, polyvinyl alcohols, polyethylene oxides, glycosaminoglycans, polysaccharides, polyesters, aliphatic polyesters, polyurethanes, polystyrenes, copolymers, silicones, silicone containing polymers, polyalkyl siloxanes, polyorthoesters, poly-anhydrides, copolymers of vinyl monomers, polycarbonates, polyethylenes, polypropylenes, polylactic acids, polylactides, polyglycolic acids, polyglycolides, polylactide-co-glycolides, polycaprolactones, poly(ϵ -caprolactone)s, polyhydroxybutyrate valerates, polyacrylamides, polyethers, polyurethane dispersions, polyacrylates, acrylic latex dispersions, polyacrylic acid, polyalkyl methacrylates, polyalkylene-co-vinyl acetates, polyalkylenes, aliphatic polycarbonates polyhydroxyalkanoates, polytetrahydroalkylenes, poly(phosphasones), polytetrahydroalkylenes, poly(phosphasones), and mixtures, combinations, and copolymers thereof. The polymers of the present invention may be natural or synthetic in origin, including gelatin, chitosan, dextrin, cyclodextrin, Poly(urethanes), Poly(siloxanes) or silicones, Poly(acrylates) such as [rho]oly(methyl methacrylate), poly(butyl methacrylate), and Poly(2-hydroxy ethyl methacrylate), Poly(vinyl alcohol) Poly(olefins) such as poly(ethylene), [rho]oly(isoprene), halogenated polymers such as Poly(tetrafluoroethylene)- and derivatives and copolymers such as those commonly sold as Teflon(R) products, Poly(vinylidene fluoride), Poly(vinyl acetate), Poly(vinyl pyrrolidone), Poly(acrylic acid), Polyacrylamide, Poly(ethylene-co-vinyl acetate), Poly(ethylene glycol), Poly(propylene glycol), Poly(methacrylic acid); etc. Suitable polymers also include absorbable and/or resorbable polymers including the following, combinations, copolymers and derivatives of the following: Polylactides (PLA), Polyglycolides (PGA), Poly-Lactide-co-glycolides (PLGA), Poly-anhydrides, Polyorthoesters, Poly(N-(2-hydroxypropyl)methacrylamide), Poly(1-aspartamide), including the derivatives DLPLA—poly(dl-lactide); LPLA—poly(l-lactide); PDO—poly(dioxanone); PGA-TMC—poly(glycolide-co-trimethylene carbonate); PGA-LPLA—poly(l-lactide-co-glycolide); PGA-DLPLA—poly(dl-lactide-co-glycolide); LPLA-DLPLA—poly(l-lactide-co-dl-lactide); and PDO-PGA-TMC—poly(glycolide-co-trimethylene carbonate-co-dioxanone), and combinations thereof.

[0466] In some embodiments of the methods and/or devices provided herein, the polymer has a dry modulus between 3,000 and 12,000 KPa. In some embodiments, the polymer is capable of becoming soft after implantation. In some embodiments, the polymer is capable of becoming soft after implantation by hydration, degradation or by a combination of hydration and degradation. In some embodiments, the polymer is adapted to transfer, free, and/or dissociate from the substrate when at the intervention site due to hydrolysis of the polymer.

[0467] In some embodiments of the methods and/or devices provided herein, the bioabsorbable polymer is capable of resorption in at least one of: about 1 day, about 3 days, about 5 days, about 7 days, about 14 days, about 3 weeks, about 4 weeks, about 45 days, about 60 days, about 90 days, about 180 days, about 6 months, about 9 months, about 1 year, about 1 to about 2 days, about 1 to about 5 days, about 1 to about 2 weeks, about 2 to about 4 weeks, about 45 to about 60 days, about 45 to about 90 days, about 30 to about 90 days, about 60 to about 90 days, about 90 to about 180 days, about 60 to about 180 days, about 180 to about 365 days, about 6 months to about 9 months, about 9 months to about 12 months, about 9 months to about 15 months, and about 1 year to about 2 years.

[0468] In some embodiments of the methods and/or devices provided herein, the coating comprises a microstructure. In some embodiments, particles of the active agent are sequestered or encapsulated within the microstructure. In some embodiments, the microstructure comprises microchannels, micropores and/or microcavities. In some embodiments, the microstructure is selected to allow sustained release of the active agent. In some embodiments, the microstructure is selected to allow controlled release of the active agent.

[0469] In some embodiments of the devices, coatings and/or methods provided herein the coating comprises a positive surface charge. The positive surface charge may be about 20 mV to about 40 mV. The positive surface charge may be at least one of: at least about 1 mV, over about 1 mV, at least about 5 mV, at least about 10 mV, about 10 mV to about 50 mV, about 20 mV to about 50 mV, about 10 mV to about 40 mV, about 30 mV to about 40 mV, about 20 mV to about 30 mV, and about 25 mV to about 35 mV.

[0470] In some embodiments of the devices, coatings and/or methods provided herein, the w/w percent of active agent in the encapsulated active agent is about 5%. In some embodiments of the devices, coatings and/or methods provided herein, the w/w percent of active agent in the encapsulated active agent is about 10-25%.

[0471] In some embodiments, the encapsulated active agent comprises a polymer at least partially encapsulating at least a portion of an active agent wherein the encapsulated active agent has a positive surface charge. In some embodiments, the active agent is not completely encapsulated. An active agent (or a portion thereof) need not be completely surrounded in order to be encapsulated by the polymer. In some embodiments, at least 10% of the surface area of the active agent is encapsulated in the polymer. In some embodiments, at least 20% of the surface area of the active agent is encapsulated in the polymer. In some embodiments, at least 25% of the surface area of the active agent is encapsulated in the polymer. In some embodiments, at least 30% of the surface area of the active agent is encapsulated in the polymer. In some embodiments, at least 40% of the surface area of the

active agent is encapsulated in the polymer. In some embodiments, at least 50% of the surface area of the active agent is encapsulated in the polymer. In some embodiments, at least 60% of the surface area of the active agent is encapsulated in the polymer. In some embodiments, at least 70% of the surface area of the active agent is encapsulated in the polymer. In some embodiments, at least 75% of the surface area of the active agent is encapsulated in the polymer. In some embodiments, at least 80% of the surface area of the active agent is encapsulated in the polymer. In some embodiments, at least 90% of the surface area of the active agent is encapsulated in the polymer. In some embodiments, at least 95% of the surface area of the active agent is encapsulated in the polymer. In some embodiments, at least one of: at least 5% of the surface area of the active agent is at least partially surrounded by the polymer, at least 10% of the surface area of the active agent is at least partially surrounded by the polymer, at least 15% of the surface area of the active agent is at least partially surrounded by the polymer, at least 20% of the surface area of the active agent is at least partially surrounded by the polymer, at least 25% of the surface area of the active agent is at least partially surrounded by the polymer, at least 30% of the surface area of the active agent is at least partially surrounded by the polymer, at least 40% of the surface area of the active agent is at least partially surrounded by the polymer, at least 50% of the surface area of the active agent is at least partially surrounded by the polymer, at least 60% of the surface area of the active agent is at least partially surrounded by the polymer, at least 70% of the surface area of the active agent is at least partially surrounded by the polymer, at least 75% of the surface area of the active agent is at least partially surrounded by the polymer, at least 80% of the surface area of the active agent is at least partially surrounded by the polymer, at least 90% of the surface area of the active agent is at least partially surrounded by the polymer, and at least 95% of the surface area of the active agent is at least partially surrounded by the polymer.

[0472] In some embodiments of the devices, coatings and/or methods provided herein, at least a portion of the encapsulated active agent are nanoparticles. At least a portion of the encapsulated active agent may be at least one of: a spherical shape, a discoidal shape, a hemispherical shape, a cylindrical shape, a conical shape, a nanoreef shape, a nanobox shape, a cluster shape, a nanotube shape, a whisker shape, a rod shape, a fiber shape, a cup shape, a jack shape, a hexagonal shape, an ellipsoid shape, an oblate ellipsoid shape, a prolate ellipsoid shape, a torus shape, a spheroid shape, a taco-like shape, a bullet shape, a barrel shape, a lens shape, a capsule shape, a pulley wheel shape, a circular disc shape, a rectangular disc shape, a hexagonal disc shape, a flying saucer-like shape, a worm shape, a ribbon-like shape, and a ravioli-like shape.

[0473] The active agent in some embodiments of the devices, coatings and/or methods provided herein comprises a macrolide immunosuppressive drug. The active agent may be selected from sirolimus, a prodrug, a hydrate, an ester, a salt, a polymorph, a derivative, and an analog thereof. A portion of the active agent may be in crystalline form.

[0474] The active agent may be, on average, at least one of: at most 5 microns, over 1 micrometer, between 1 micrometer and 5 micrometers, about 1.5 micrometers on average, and about 2.5 micrometers on average. In some embodiments, the size of the active agent in the coating is controlled in order to improve drug retention in the artery. For non-limiting example, in the case of sirolimus as an active agent, the

sirolimus may have an average size (mean diameter) of at least one of: 1.5 μm , 2.5 μm , 645 nm, 100-200 nm, another controlled size, or a combination thereof. In some embodiments, the active agent is sirolimus and wherein the sirolimus has a median size of at least one of: 1.5 μm , 2.5 μm , 645 nm, 100-200 nm, another controlled size, or a combination thereof. In some embodiments, the active agent is sirolimus and wherein the sirolimus has an average size (mean diameter) of at least one of: about 1.5 μm , about 2.5 μm , about 645 nm, about 100-200 nm, another controlled size, or a combination thereof. In some embodiments, the active agent is sirolimus and wherein the sirolimus has a median size of at least one of: about 1.5 μm , about 2.5 μm , about 645 nm, about 100-200 nm, another controlled size, or a combination thereof. In some embodiments the size of the active agent is controlled. For example, in some embodiments, sirolimus is the active agent and at least 75% of the sirolimus as is 1.5 μm , 2.5 μm , 645 nm, 100-200 nm, or another controlled size. In some embodiments, sirolimus is the active agent and at least 50% of the sirolimus as is 1.5 μm , 2.5 μm , 645 nm, 100-200 nm, or another controlled size. In some embodiments, sirolimus is the active agent and at least 90% of the sirolimus as is 1.5 μm , 2.5 μm , 645 nm, 100-200 nm, or another controlled size. In some embodiments, sirolimus is the active agent and at least 95% of the sirolimus as is 1.5 μm , 2.5 μm , 645 nm, 100-200 nm, or another controlled size. In some embodiments, sirolimus is the active agent and at least 98% of the sirolimus as is 1.5 μm , 2.5 μm , 645 nm, 100-200 nm, or another controlled size. In some embodiments, sirolimus is the active agent and at least 99% of the sirolimus as is 1.5 μm , 2.5 μm , 645 nm, 100-200 nm, or another controlled size.

[0475] In some embodiments of the devices, coatings and/or methods provided herein the coating delivers the active agent to the treatment site over at least about 1 day. In some embodiments of the devices, coatings and/or methods provided herein the coating delivers the active agent to the treatment site over at least one of: about 3 days, about 5 days, about 1 week, about 1.5 weeks, about 2 weeks, about 14 days, about 3 weeks, about 21 days, about 4 weeks, about 28 days, about 1 month, about 1.5 months, about 2 months, at least about 3 days, at least about 5 days, at least about 1 week, at least about 1.5 weeks, at least about 2 weeks, at least about 14 days, at least about 3 weeks, at least about 21 days, at least about 4 weeks, at least about 28 days, at least about 1 month, at least about 1.5 months, at least about 2 months, about 7 to about 14 days, about 14 to about 21 days, about 14 to about 28 days, about 21 to about 28 days, and about 7 to about 28 days.

[0476] In some embodiments of the devices, coatings and/or methods provided herein the treatment site is a vessel wall. In some embodiments of the devices, coatings and/or methods provided herein the treatment site is a coronary artery. In some embodiments of the devices, coatings and/or methods provided herein the treatment site is bypass graft. In some embodiments of the devices, coatings and/or methods provided herein the treatment site is a bifurcated lesion. In some embodiments of the devices, coatings and/or methods provided herein the treatment site is a small coronary lesions (for example, with reference diameter < 2.5 mm). In some embodiments of the devices, coatings and/or methods provided herein the treatment site is a peripheral artery. In some embodiments of the devices, coatings and/or methods provided herein the treatment site is vein. In some embodiments of the devices, coatings and/or methods provided herein the treatment site is an AV graft. In some embodiments of the

devices, coatings and/or methods provided herein the treatment site is an AV fistula. In some embodiments of the devices, coatings and/or methods provided herein the treatment site is a biliary tract. In some embodiments of the devices, coatings and/or methods provided herein the treatment site is a biliary duct. In some embodiments of the devices, coatings and/or methods provided herein the treatment site is a sinus. In some embodiments of the devices, coatings and/or methods provided herein the treatment site is a vein graft.

[0477] In some embodiments of the devices, coatings and/or methods provided herein the coating comprises a positive surface charge on a surface of the coating configured to contact the treatment site.

[0478] In some embodiments of the devices, coatings and/or methods provided herein the encapsulated active agent are micelles.

[0479] In some embodiments of the devices, coatings and/or methods provided herein the medical device comprises a balloon. In some embodiments the medical device is a balloon of a balloon catheter.

[0480] In some embodiments of the devices, coatings and/or methods provided herein depositing the encapsulated active agent comprises using an eSTAT process. In some embodiments of the devices, coatings and/or methods provided herein depositing a second polymer on the medical device following depositing the encapsulated active agent on the medical device.

[0481] In some embodiments of the methods, coatings or and/or devices provided herein, the coating is formed on the substrate by a process comprising depositing a polymer and/or the active agent by an RESS, e-RESS, an e-SEDS, or an e-DPC process. In some embodiments of the methods and/or devices provided herein, wherein the coating is formed on the substrate by a process comprising at least one of: depositing a polymer by an RESS, e-RESS, an e-SEDS, or an e-DPC process, and depositing the pharmaceutical agent by an e-RESS, an e-SEDS, eSTAT, or an e-DPC process. In some embodiments of the methods and/or devices provided herein, the coating is formed on the substrate by a process comprising at least one of: depositing a polymer by an RESS, e-RESS, an e-SEDS, or an e-DPC process, and depositing the active agent by an eSTAT, e-RESS, an e-SEDS, or an e-DPC process. In some embodiments, the process of forming the coating provides improved adherence of the coating to the substrate prior to deployment of the device at the intervention site and facilitates dissociation of the coating from the substrate at the intervention site. In some embodiments, the coating is formed on the substrate by a process comprising depositing the active agent by an eSTAT, e-RESS, an e-SEDS, or an e-DPC process without electrically charging the substrate. In some embodiments, the coating is formed on the substrate by a process comprising depositing the active agent on the substrate by an e-RESS, an e-SEDS, or an e-DPC process without creating an electrical potential between the substrate and a coating apparatus used to deposit the coating.

[0482] In some embodiments of the devices, coatings and/or methods provided herein the second polymer comprises PLGA. The PLGA may have at least one of: a MW of about 30 KDa and a Mn of about 15 KDa, a Mn of about 10 KDa to about 25 KDa, and a MW of about 15 KDa to about 40 KDa. Depositing the second polymer on the medical device may use at least one of a RESS coating process, an eSTAT coating process, a dip coating process, and a spray coating process.

[0483] In some embodiments of the methods, coatings, and/or devices provided herein, the intervention site is in or on the body of a subject. In some embodiments, the intervention site is a vascular wall. In some embodiments, the intervention site is a non-vascular lumen wall. In some embodiments, the intervention site is a vascular cavity wall. In some embodiments of the methods and/or devices provided herein, the intervention site is a wall of a body cavity. In some embodiments, the body cavity is the result of a lumpectomy. In some embodiments, the intervention site is a cannulized site within a subject. In some embodiments of the methods and/or devices provided herein, the intervention site is a sinus wall. In some embodiments, the intervention site is a sinus cavity wall. In some embodiments, the active agent comprises a corticosteroid.

[0484] In some embodiments of the methods, coatings, and/or devices provided herein, the coating is capable of at least one of: retarding healing, delaying healing, and preventing healing. In some embodiments, the coating is capable of at least one of: retarding, delaying, and preventing the inflammatory phase of healing. In some embodiments, the coating is capable of at least one of: retarding, delaying, and preventing the proliferative phase of healing. In some embodiments, the coating is capable of at least one of: retarding, delaying, and preventing the maturation phase of healing. In some embodiments, the coating is capable of at least one of: retarding, delaying, and preventing the remodeling phase of healing. In some embodiments, the active agent comprises an anti-angiogenic agent.

[0485] Provided herein is a method comprising providing a medical device, wherein the medical device comprises a substrate and a coating on at least a portion of the substrate, and wherein the coating comprises a plurality of layers, wherein at least one layer comprises a pharmaceutical agent in a therapeutically desirable morphology, and transferring at least a portion of the coating from the substrate to the intervention site upon stimulating the coating with a stimulation.

[0486] Other compounds that may be used in lieu of Sirolimus (or in addition thereto) include, for non-limiting example: Sirolimus which has a FKBP12 binding (nM) of 0.4-2.3 nM and an Antiproliferative potency (nM) of 0.1-3.5 nM; Everolimus which has a FKBP12 binding (nM) of 1.8-2.6 nM and an Antiproliferative potency (nM) of 0.9-3.6 nM; Zotarolimus which has a FKBP12 binding (nM) of 2.0-3.2 nM and an Antiproliferative potency (nM) of 0.2-2.7 nM; Biolimus which has an Antiproliferative potency (nM) of about 10 nM; Temsirolimus which has a FKBP12 binding (nM) and an Antiproliferative potency (nM) that is about the same as Sirolimus; Tacrolimus which has a FKBP12 binding (nM) of 0.2-0.4 nM and an Antiproliferative potency (nM) of about 350 nM; Pimecrolimus which has a FKBP12 binding (nM) of about 1.2 nM and an Antiproliferative potency (nM) of about 1 μ M.

[0487] Alternative compounds that may be used in lieu of sirolimus (or in addition thereto) include drugs that were not sufficiently potent to effectively deliver from a drug stent platform may be more effective when delivered from a coated balloon (if the drug is highly lipophilic), for non-limiting example: Dipyradamole, Cerivastatin, Troglitazone, and/or Cilostazol. Dipyradamole may be an appropriate drug for use on a coating of a balloon, for example, since it inhibits VSMC (vascular smooth muscle cell) proliferation, is anti-inflammatory, improves endothelial function, and provides local release of t-PA (tissue plasminogen activator). Cerivastatin

may be an appropriate drug for use on a coating of a balloon, for example, since it inhibits VSMC proliferation, is anti-inflammatory, improves endothelial function, and can stabilize vulnerable plaque. Troglitazone may be an appropriate drug for use on a coating of a balloon, for example, since it inhibits VSMC proliferation, is anti-inflammatory, improves endothelial function, and may provide vascular lipid reduction. Cilostazol may be an appropriate drug for use on a coating of a balloon, for example, since it inhibits VSMC proliferation, may be anti-inflammatory, improves endothelial function, and is a vasodilator and/or increases NO (nitric oxide) release and/or production of NO.

[0488] Other drugs that may be appropriate for use on a drug balloon as a coating that is released thereby include the following: Drugs to prevent elastic recoil such as smooth muscle cell relaxants and/or agents that bind elastin; Drugs to prevent reperfusion injury such as ANP, atorvastatin, erythropoietin, and/or glucagon-like peptide 1; Drugs to stimulate collateral blood flow such as Vasodilators and/or Growth factors (GF) and GF activators. Drug coated balloons may be useful in lower extremities and in peripheral indications, such as in PTA (Percutaneous transluminal angioplasty) and in combination with a bare stent, in situations of in stent restenosis, following atherectomy. Drug coated balloons may be particularly useful in certain coronary indications, such as following in stent restenosis, in small vessel angioplasty situations, in bifurcations, and in combination with a bare metal stent. Other uses include in AV Fistulae and Grafts (dialysis), in the nasal sinus, in neurovascular vessels, in renal vessels or applications, in anti-cancer applications, and in urological applications. a) Fistulae and Grafts (dialysis) Fistulae and Grafts (dialysis)Fistulae and Grafts (dialysis).

[0489] In some embodiments, the device releases at least 3% of the active agent to artery in vivo. In some embodiments, the device releases at least 5% of the active agent to artery in vivo. In some embodiments, the device releases at least 10% of the active agent in vivo. In some embodiments, the device releases at least 5% of the active agent to artery upon inflation of the balloon in vivo. In some embodiments, the device releases at least 7% of the active agent to artery upon inflation of the balloon in vivo. In some embodiments, the device releases at least 10% of the active agent to artery upon inflation of the balloon in vivo. In some embodiments, the device releases at least 15% of the active agent to artery upon inflation of the balloon in vivo. In some embodiments, the device releases at least 20% of the active agent to artery upon inflation of the balloon in vivo. In some embodiments, the device releases at least 25% of the active agent to artery upon inflation of the balloon in vivo. In some embodiments, the device releases at least 30% of the active agent to artery upon inflation of the balloon in vivo. In some embodiments, the device releases at least 40% of the active agent to artery upon inflation of the balloon in vivo. In some embodiments, the device releases at least 50% of the active agent to artery upon inflation of the balloon in vivo. In some embodiments, the device releases between 2% and 50% of the active agent to artery upon inflation of the balloon in vivo. In some embodiments, the device releases between 3% and 50% of the active agent to artery upon inflation of the balloon in vivo. In some embodiments, the device releases between 5% and 50% of the active agent to artery upon inflation of the balloon in vivo. In some embodiments, the device releases between 3% and 30% of the active agent to artery upon inflation of the balloon in vivo. In some embodiments, the device releases between 3% and 25%

of the active agent to artery upon inflation of the balloon in vivo. In some embodiments, the device releases between 3% and 20% of the active agent to artery upon inflation of the balloon in vivo. In some embodiments, the device releases between 3% and 15% of the active agent to artery upon inflation of the balloon in vivo. In some embodiments, the device releases between 1% and 15% of the active agent to artery upon inflation of the balloon in vivo. In some embodiments, the device releases between 1% and 10% of the active agent to artery upon inflation of the balloon in vivo. In some embodiments, the device releases between 3% and 10% of the active agent to artery upon inflation of the balloon in vivo. In some embodiments, the device releases between 1% and 5% of the active agent to artery upon inflation of the balloon in vivo.

[0490] As used herein, depending on the embodiment, "upon inflation" means as soon as reasonably possible following removal of the device from the treatment site. This may include timings such as about 1 minute, about 5 minutes from removal of the device from the treatment site, within 1 to 15 minutes from the removal of the device from the treatment site, within 1 to 15 minutes from the removal of the device from the treatment site, within 1 to 20 minutes from the removal of the device from the treatment site, within 1 minute to 1 hour from the removal of the device from the treatment site, within 1 minute to 2 hour from the removal of the device from the treatment site, and/or within 1 minute to 3 hours from the removal of the device from the treatment site.

Example 5

Delivery of Rapamycin From Coated Invertable Balloons

[0491] Provided herein is a device comprising an invertable balloon, a coating on the abluminal side of the invertable balloon, wherein the coating comprises an active agent and a binding agent. In some embodiments, the device releases at least 3% of the active agent to artery upon inflation of the balloon in vivo.

[0492] In some embodiments, the device releases at least 5% of the active agent to artery upon inflation of the balloon in vivo. In some embodiments, the device releases at least 7% of the active agent to artery upon inflation of the balloon in vivo. In some embodiments, the device releases at least 10% of the active agent to artery upon inflation of the balloon in vivo. In some embodiments, the device releases at least 15% of the active agent to artery upon inflation of the balloon in vivo. In some embodiments, the device releases at least 20% of the active agent to artery upon inflation of the balloon in vivo. In some embodiments, the device releases at least 25% of the active agent to artery upon inflation of the balloon in vivo. In some embodiments, the device releases at least 30% of the active agent to artery upon inflation of the balloon in vivo. In some embodiments, the device releases at least 40% of the active agent to artery upon inflation of the balloon in vivo. In some embodiments, the device releases at least 50% of the active agent to artery upon inflation of the balloon in vivo. In some embodiments, the device releases between 2% and 50% of the active agent to artery upon inflation of the balloon in vivo. In some embodiments, the device releases between 3% and 50% of the active agent to artery upon inflation of the balloon in vivo. In some embodiments, the device releases between 5% and 50% of the active agent to artery upon inflation of the balloon in vivo. In some embodiments, the device releases between 3% and 50% of the active agent to artery upon inflation of the balloon in vivo. In some embodi-

ments, the device releases between 3% and 30% of the active agent to artery upon inflation of the balloon in vivo. In some embodiments, the device releases between 3% and 25% of the active agent to artery upon inflation of the balloon in vivo. In some embodiments, the device releases between 3% and 20% of the active agent to artery upon inflation of the balloon in vivo. In some embodiments, the device releases between 3% and 15% of the active agent to artery upon inflation of the balloon in vivo. In some embodiments, the device releases between 1% and 15% of the active agent to artery upon inflation of the balloon in vivo. In some embodiments, the device releases between 1% and 10% of the active agent to artery upon inflation of the balloon in vivo. In some embodiments, the device releases between 3% and 10% of the active agent to artery upon inflation of the balloon in vivo. In some embodiments, the device releases between 1% and 5% of the active agent to artery upon inflation of the balloon in vivo.

[0493] Example investable balloons (which may also and/or alternatively be called evertable balloons) include, but are not limited to, those described in U.S. 6039721 filed Dec. 3, 1997; and U.S. 4606347 filed Aug. 8, 1985 which patents are incorporated herein by reference in their entirety. In some embodiments the abluminal surface of the balloon is coated prior to inversion, and once coated, the balloon is inverted such that the abluminal surface of the balloon is protected from either blood flow during tracking or tracking contact with the vessel wall, or both, until the balloon catheter is positioned near the treatment site, usually just proximally to the site. As used herein, “abluminal side” or “abluminal surface” refers to a portion of the balloon having coating thereon, and intended to deliver the coating (agent) to the treatment site or location—i.e. the lumen of the vessel in the case of a treatment site that is a vessel. The balloon is then un-inverted such that the abluminal surface is positioned within the treatment site.

[0494] In an embodiment wherein the balloon is inverted within a catheter, it may be pushed out of the catheter using either pressure from the inflater or another form of un-inversion of the balloon, such as for nonlimiting example, by moving the distal end of the balloon distally through the balloon itself, essentially unrolling the balloon into the treatment site such that the coated portion of the balloon is adjacent the treatment site. In certain embodiments where the balloon is inverted on the outside of the catheter, a similar movement and/or pressure from the inflater can move the distal end of the balloon distally thereby unrolling the coated side of the balloon into proximity of the treatment site. In some embodiments, the balloon may be partially un-inverted, such that the treatment length may be controlled. The balloon thereafter is inflated such that the abluminal surface that is coated contacts and/or dilates the treatment site, thereby delivering the coating or a portion thereof to the treatment site.

[0495] Any of the devices, coatings, and/or methods described herein may be combined with an invertible type of balloon to deliver the coating in a manner that reduces and/or substantially eliminates loss of coating due to tracking and/or blood flow and/or other in-transit coating loss prior to locating the device at the treatment site (i.e. delivering the device to the treatment site). In some embodiments, at most 1% of coating is removed from the balloon due to tracking of the coated balloon to the treatment site. In some embodiments, at most 3% of coating is removed from the balloon due to tracking of the coated balloon to the treatment site. In some

embodiments, at most 5% of coating is removed from the balloon due to tracking of the coated balloon to the treatment site. In some embodiments, at most 10% of coating is removed from the balloon due to tracking of the coated balloon to the treatment site. In some embodiments, at most 15% of coating is removed from the balloon due to tracking of the coated balloon to the treatment site. In some embodiments, at most 20% of coating is removed from the balloon due to tracking of the coated balloon to the treatment site. In some embodiments, at most 25% of coating is removed from the balloon due to tracking of the coated balloon to the treatment site. In some embodiments, at most 30% of coating is removed from the balloon due to tracking of the coated balloon to the treatment site.

[0496] As used herein, depending on the embodiment, “upon inflation” means as soon as reasonably possible following removal of the device from the treatment site. This may include timings such as about 1 minute, about 5 minutes from removal of the device from the treatment site, within 1 to 15 minutes from the removal of the device from the treatment site, within 1 to 15 minutes from the removal of the device from the treatment site, within 1 to 20 minutes from the removal of the device from the treatment site, within 1 minute to 1 hour from the removal of the device from the treatment site, within 1 minute to 2 hour from the removal of the device from the treatment site, and/or within 1 minute to 3 hours from the removal of the device from the treatment site.

Example 6

Delivery of Rapamycin from Sheathed Coated Balloons

[0497] Provided herein is a device comprising an balloon, a coating on the abluminal side of the balloon, and a sheath over the balloon, wherein the coating comprises an active agent and a binding agent. In some embodiments, the device releases at least 3% of the active agent to artery upon inflation of the balloon in vivo. In some embodiments, the sheath may be retracted. In some embodiments, the sheath may be retracted to expose the coating to the treatment site. In some embodiments, the sheath covers the coated balloon until the balloon reaches the treatment site. In some embodiments the sheath may be retracted once the coated balloon is positioned near and/or at the treatment site. In some embodiments, the sheath covers the coated balloon until the balloon is proximal to the treatment site. In some embodiments, the sheath covers the coated balloon until the balloon is distal to the treatment site. In some embodiments, the sheath covers the coated balloon until the balloon is within to the treatment site. In some embodiments, the sheath may be moved over the balloon following deflation of the balloon after the coating (or a portion thereof) has been released to the artery, and the catheter may be removed such that the coated balloon is covered during removal from the subject. In some embodiments, the sheath may remain in a retracted state following deflation of the balloon after the coating (or a portion thereof) has been released to the artery, and the catheter may be removed such that the coated balloon is exposed to the delivery track during removal from the subject.

[0498] Any of the devices, coatings, and/or methods described herein may be combined with a sheath to deliver the coating in a manner that reduces and/or substantially eliminates loss of coating due to tracking and/or blood flow and/or other in-transit coating loss prior to locating the device at the

treatment site (i.e. delivering the device to the treatment site). In some embodiments, at most 1% of coating is removed from the balloon due to tracking of the coated balloon to the treatment site. In some embodiments, at most 3% of coating is removed from the balloon due to tracking of the coated balloon to the treatment site. In some embodiments, at most 5% of coating is removed from the balloon due to tracking of the coated balloon to the treatment site. In some embodiments, at most 10% of coating is removed from the balloon due to tracking of the coated balloon to the treatment site. In some embodiments, at most 15% of coating is removed from the balloon due to tracking of the coated balloon to the treatment site. In some embodiments, at most 20% of coating is removed from the balloon due to tracking of the coated balloon to the treatment site. In some embodiments, at most 25% of coating is removed from the balloon due to tracking of the coated balloon to the treatment site. In some embodiments, at most 30% of coating is removed from the balloon due to tracking of the coated balloon to the treatment site.

[0499] In some embodiments, the device releases at least 5% of the active agent to artery upon inflation of the balloon in vivo. In some embodiments, the device releases at least 7% of the active agent to artery upon inflation of the balloon in vivo. In some embodiments, the device releases at least 10% of the active agent to artery upon inflation of the balloon in vivo. In some embodiments, the device releases at least 15% of the active agent to artery upon inflation of the balloon in vivo. In some embodiments, the device releases at least 20% of the active agent to artery upon inflation of the balloon in vivo. In some embodiments, the device releases at least 25% of the active agent to artery upon inflation of the balloon in vivo. In some embodiments, the device releases at least 30% of the active agent to artery upon inflation of the balloon in vivo. In some embodiments, the device releases at least 40% of the active agent to artery upon inflation of the balloon in vivo. In some embodiments, the device releases at least 50% of the active agent to artery upon inflation of the balloon in vivo. In some embodiments, the device releases between 2% and 50% of the active agent to artery upon inflation of the balloon in vivo. In some embodiments, the device releases between 3% and 50% of the active agent to artery upon inflation of the balloon in vivo. In some embodiments, the device releases between 5% and 50% of the active agent to artery upon inflation of the balloon in vivo. In some embodiments, the device releases between 3% and 30% of the active agent to artery upon inflation of the balloon in vivo. In some embodiments, the device releases between 3% and 25% of the active agent to artery upon inflation of the balloon in vivo. In some embodiments, the device releases between 3% and 20% of the active agent to artery upon inflation of the balloon in vivo. In some embodiments, the device releases between 3% and 15% of the active agent to artery upon inflation of the balloon in vivo. In some embodiments, the device releases between 1% and 15% of the active agent to artery upon inflation of the balloon in vivo. In some embodiments, the device releases between 1% and 10% of the active agent to artery upon inflation of the balloon in vivo. In some embodiments, the device releases between 3% and 10% of the active agent to artery upon inflation of the balloon in vivo. In some embodiments, the device releases between 1% and 5% of the active agent to artery upon inflation of the balloon in vivo.

[0500] As used herein, depending on the embodiment, "upon inflation" means as soon as reasonably possible following removal of the device from the treatment site. This

may include timings such as about 1 minute, about 5 minutes from removal of the device from the treatment site, within 1 to 15 minutes from the removal of the device from the treatment site, within 1 to 15 minutes from the removal of the device from the treatment site, within 1 to 20 minutes from the removal of the device from the treatment site, within 1 minute to 1 hour from the removal of the device from the treatment site, within 1 minute to 2 hour from the removal of the device from the treatment site, and/or within 1 minute to 3 hours from the removal of the device from the treatment site.

Example 7

Delivery of Rapamycin from Coated Balloons with Occluder

[0501] Provided herein is a device comprising a balloon, a coating on the balloon, and an occluder, wherein the coating comprises an active agent and a binding agent. In some embodiments, the occluder is a flow occluder configured to block the flow of bodily fluids (e.g. blood) at the treatment site during exposure of the coating to the treatment site. In some embodiments, the device releases at least 3% of the active agent to artery upon inflation of the balloon in vivo. In some embodiments, the occluder comprises a second balloon that occludes the flow of the blood at the treatment site. In some embodiments, the balloon comprises the occluder, such that the balloon has two sections the flow occluder and the coated portion, wherein the flow occluder occludes the flow of the blood at the treatment site. In some embodiments, the balloon is dual-noded, wherein the distal node is coated and wherein the proximal node is the occluder. In some embodiments, the occluder is located proximally from the balloon, and/or portion thereof, having coating thereon. In some embodiments, the balloon is dual-noded, wherein the proximal node is coated and wherein the distal node is the occluder. In some embodiments the occluder is located distally from the balloon, and/or portion thereof, having coating thereon. In some embodiments, the balloon is a shape appropriate for the treatment site, such that the occluder portion of the balloon is the appropriate shape to occlude flow of blood at the treatment site. In some embodiments, the occluder substantially conforms to the shape of a treatment area near the treatment site such blood flow at the treatment site is occluded thereby. In some embodiments, the balloon is only partially coated, such that either or both the distal and proximal end of the balloon is not coated, and the distal and/or proximal end of the balloon is the occluder.

[0502] Provided herein is a device comprising a first balloon, a coating on the first balloon, and a second balloon capable of occluding flow of blood at the treatment site during expansion of the first balloon at the treatment site. In some embodiments, the occluder is a second balloon which is not the balloon having coating thereon. In some embodiments, the occluder is located proximally from the balloon, and/or portion thereof, having coating thereon. In some embodiments the occluder is located distally from the balloon, and/or portion thereof, having coating thereon.

[0503] Provided herein is a device comprising a first balloon, a coating on the first balloon, and a second balloon configured such that the second balloon expands prior to expansion of the first balloon. In some embodiments the occluder occludes the flow of the blood at the treatment prior to expansion of the portion of the balloon. In some embodiments, the occluder is located proximally from the balloon,

and/or portion thereof, having coating thereon. In some embodiments the occluder is located distally from the balloon, and/or portion thereof, having coating thereon.

[0504] In some embodiments, the occluder is not a balloon, but is another form of occluder that is configured to occlude flow of blood at the treatment site. In some embodiments, the occluder is deployable and retractable, such that it can be deployed prior to inflation of the balloon having coating thereon, and following balloon inflation and delivery of the agent to the treatment site, the occluder can be retracted and removed either with the removal of the balloon, or following removal of the balloon from the treatment site.

[0505] In some embodiments, the occluder has a second coating thereon, having a second agent and/or polymer coated thereon as described elsewhere herein, according to any of the methods and processes as noted herein. The second coating in some embodiments comprises a binding agent. The second coating in some embodiments does not comprise a binding agent.

[0506] In some embodiments, the device releases at least 5% of the active agent to artery upon inflation of the balloon in vivo. In some embodiments, the device releases at least 7% of the active agent to artery upon inflation of the balloon in vivo. In some embodiments, the device releases at least 10% of the active agent to artery upon inflation of the balloon in vivo. In some embodiments, the device releases at least 15% of the active agent to artery upon inflation of the balloon in vivo. In some embodiments, the device releases at least 20% of the active agent to artery upon inflation of the balloon in vivo. In some embodiments, the device releases at least 25% of the active agent to artery upon inflation of the balloon in vivo. In some embodiments, the device releases at least 30% of the active agent to artery upon inflation of the balloon in vivo. In some embodiments, the device releases at least 40% of the active agent to artery upon inflation of the balloon in vivo. In some embodiments, the device releases at least 50% of the active agent to artery upon inflation of the balloon in vivo. In some embodiments, the device releases between 2% and 50% of the active agent to artery upon inflation of the balloon in vivo. In some embodiments, the device releases between 3% and 50% of the active agent to artery upon inflation of the balloon in vivo. In some embodiments, the device releases between 3% and 30% of the active agent to artery upon inflation of the balloon in vivo. In some embodiments, the device releases between 3% and 25% of the active agent to artery upon inflation of the balloon in vivo. In some embodiments, the device releases between 3% and 20% of the active agent to artery upon inflation of the balloon in vivo. In some embodiments, the device releases between 3% and 15% of the active agent to artery upon inflation of the balloon in vivo. In some embodiments, the device releases between 1% and 15% of the active agent to artery upon inflation of the balloon in vivo. In some embodiments, the device releases between 1% and 10% of the active agent to artery upon inflation of the balloon in vivo. In some embodiments, the device releases between 3% and 10% of the active agent to artery upon inflation of the balloon in vivo. In some embodiments, the device releases between 1% and 5% of the active agent to artery upon inflation of the balloon in vivo.

[0507] Much of the description herein is provided with reference to a balloon and a treatment site that is an artery for ease of description and brevity. Nevertheless, the methods,

descriptions, devices, and coatings described herein apply to alternative devices and treatment locations.

[0508] Unless otherwise stated, use of the term “about” in this description can mean variations of 0.1%, 0.5%, 1%, 2%, 3%, 5%, 10%, 15%, 20%, 25%, 30%, 40%, and/or 50%, depending on the particular embodiment. Where the element being described is itself expressed as a percent, the variations are not meant to be percents of percents, rather they are variations as an absolute percent—i.e. an element that is expressed as “about 5%” may be actually 5%+/-1%, or from 4% to 6%, depending on the embodiment. Only the variations that would be rational to one of ordinary skill in the art are contemplated herein. For example, where the element itself is expressed as a small percent, and a person of ordinary skill would know that the element is not rational to go below 0, the variations contemplated would not go below zero (i.e. about 5% could mean 5%+/-5% or 0-10%, but not 5%+/-10% or -5% to 15%, where this is not reasonable to one of skill in the art for the element being described).

[0509] The foregoing is illustrative of the present invention, and is not to be construed as limiting thereof. While embodiments of the present invention have been indicated and described herein, it will be obvious to those skilled in the art that such embodiments are provided by way of example only. Numerous variations, changes, and substitutions will now occur to those skilled in the art without departing from the invention. It should be understood that various alternatives to the embodiments of the invention described herein may be employed in practicing the invention. It is intended that the following claims define the scope of the invention and that methods and structures within the scope of these claims and their equivalents be covered thereby.

1. A medical device comprising:
 - a balloon; and
 - a coating on at least a portion of the balloon, wherein the coating comprises an active agent and a binding agent, and wherein the device releases at least 3% of the active agent to artery five minutes after expansion of the balloon in the artery in vivo.
2. (canceled)
3. The medical device of claim 1, wherein the binding agents comprises at least one of: Polyarginine, Polyarginine 9-L-pArg, DEAE-Dextran (Diethylaminoethyl cellulose-Dextran), DMAB (Didodecyldimethylammonium bromide), PEI (Polyethyleneimine), TAB (Tetradodecylammonium bromide), and DMTAB (Dimethylditetradecylammonium bromide).
4. The medical device of claim 1, wherein the active agent is sirolimus and wherein the sirolimus has an average size of at least one of: 1.5 μm , 2.5 μm , 645 nm, and 100-200 nm.
5. (canceled)
6. (canceled)
7. (canceled)
8. The medical device of claim 1, wherein the coating comprised and a 10:1 ratio of the active agent to the binding agent, wherein the active agent comprises sirolimus wherein the binding agent comprises Polyarginine.
9. (canceled)
10. The medical device of claim 1, wherein at least about 3 ng/mg of active agent are found in arterial tissue 72 hours after inflation of the balloon in the artery.
11. (canceled)
12. (canceled)

13. (canceled)
14. A method comprising—providing a device comprising a balloon; and a coating on at least a portion of the balloon, wherein the coating comprises an active agent and a binding agent, and wherein the device is configured to transfer to tissue of an artery at least 3% of the active agent five minutes after inflation and expansion of the balloon in the artery in vivo.
15. (canceled)
16. The method of claim 14, wherein the binding agents comprises at least one of:
Polyarginine, Polyarginine 9-L-pArg, DEAE-Dextran (Diethylaminoethyl cellulose-Dextran), DMAB (Didodecyldimethylammonium bromide), PEI (Polyethyleneimine), TAB (Tetradodecylammonium bromide), and DMTAB (Dimethylditetradecylammonium bromide).
17. (canceled)
18. The method of claim 14, wherein the active agent is sirolimus and wherein the sirolimus has have an average size of at least one of: 1.5 μm , 2.5 μm , 645 nm, and 100-200 nm.
19. (canceled)
20. (canceled)
21. The method of claim 14, wherein the coating comprised and a 10:1 ratio of the active agent to the binding agent, wherein the active agent comprises sirolimus wherein the binding agent comprises Polyarginine.
22. (canceled)
23. The method of claim 14, comprising lyophilizing the active agent and the binding agent prior to depositing the active agent and the binding agent on the balloon.
24. The method of claim 14, wherein at least about 3 ng/mg of active agent are found in arterial tissue 72 hours after inflation of the balloon in the artery.
25. (canceled)
26. (canceled)
27. (canceled)
28. The medical device of claim 1, wherein the balloon comprises an invertable portion, and wherein the coating is on an abluminal side of the invertable portion of the balloon.
29. (canceled)
30. (canceled)
31. (canceled)
32. The method of claim 14 wherein the portion of the balloon having the coating thereon is invertable.
33. (canceled)
34. (canceled)
35. (canceled)
36. The medical device of claim 1 comprising: a sheath over the portion of the balloon having coating thereon.
37. (canceled)
38. (canceled)
39. The method of claim 14 wherein the device comprises a sheath over the portion of the balloon having coating thereon.
40. (canceled)
41. (canceled)
42. The medical device of claim 1 comprising: an occluder configured to block the flow of bodily fluids at a treatment site during exposure of the coating to the tissue.
43. (canceled)
44. The medical device of claim 42, wherein the occluder comprises a second balloon.
45. (canceled)
46. The medical device of claim 42, wherein the balloon comprises a distal node and a proximal node, and wherein the distal node comprises the coating and wherein the proximal node comprises the occluder.
47. The method of claim 14 wherein the device comprises an occluder configured to block the flow of bodily fluids at a treatment site during exposure of the coating to the tissue.
48. (canceled)
49. (canceled)
50. (canceled)
51. (canceled)
52. (canceled)
53. (canceled)
54. (canceled)
55. The method of claim 14, wherein at least one of: at most 1% of coating is removed from the balloon due to tracking of the coated balloon to the treatment site, at most 5% of coating is removed from the balloon due to tracking of the coated balloon to the treatment site, at most 10% of coating is removed from the balloon due to tracking of the coated balloon to the treatment site, at most 15% of coating is removed from the balloon due to tracking of the coated balloon to the treatment site, at most 20% of coating is removed from the balloon due to tracking of the coated balloon to the treatment site, at most 25% of coating is removed from the balloon due to tracking of the coated balloon to the treatment site, and at most 30% of coating is removed from the balloon due to tracking of the coated balloon to the treatment site.
56. (canceled)
57. (canceled)
58. (canceled)
59. (canceled)
- * * * * *