

Sept. 21, 1971

R. JOERGER ET AL

3,606,919

CONTAINER

Filed July 25, 1969

2 Sheets-Sheet 1

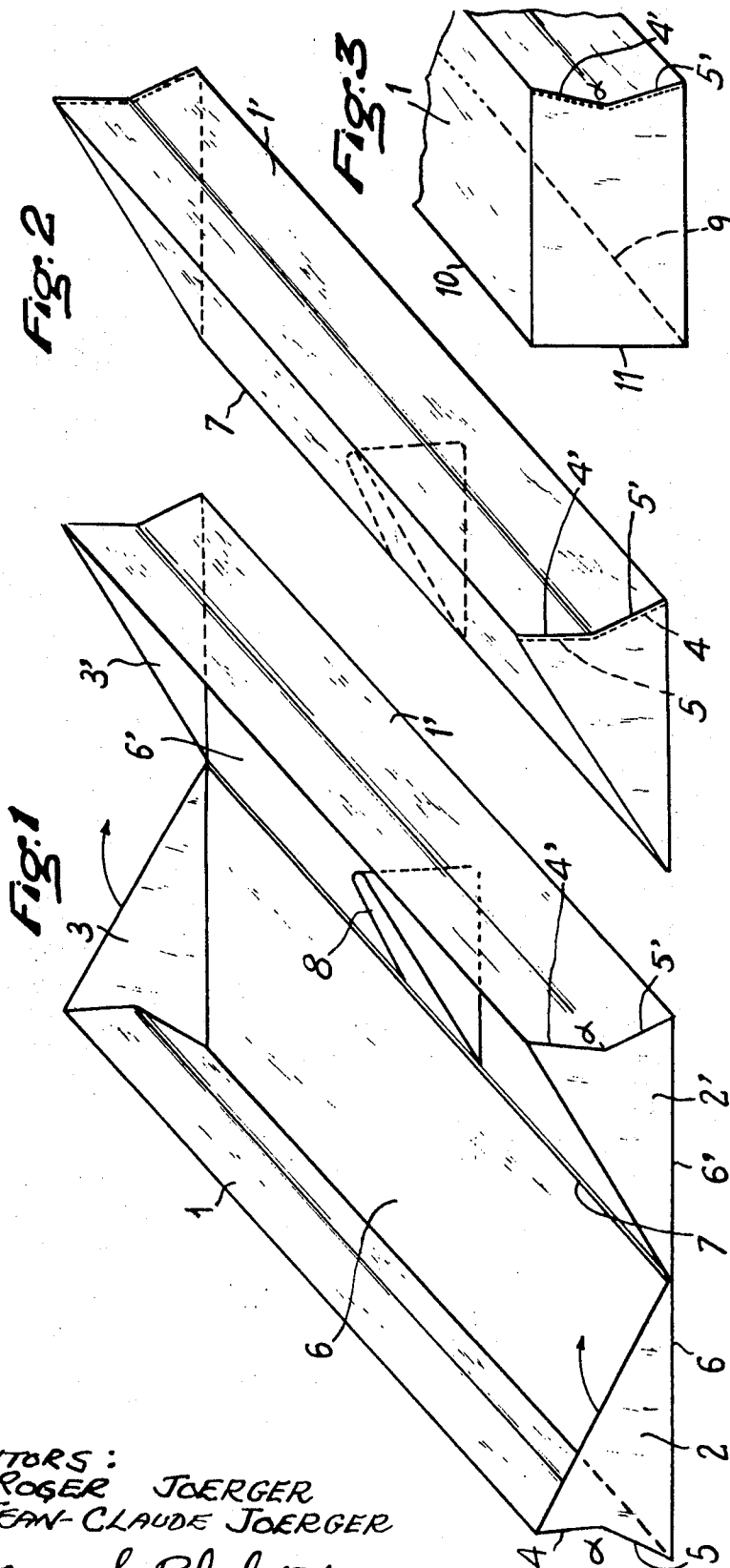

INVENTORS:  
ROGER JOERGER  
JEAN-CLAUDE JOERGER  
BY *Harold S. Blodgett*  
ATTORNEY

Fig. 4

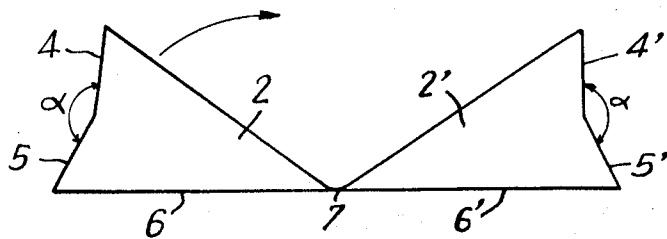

Fig. 5

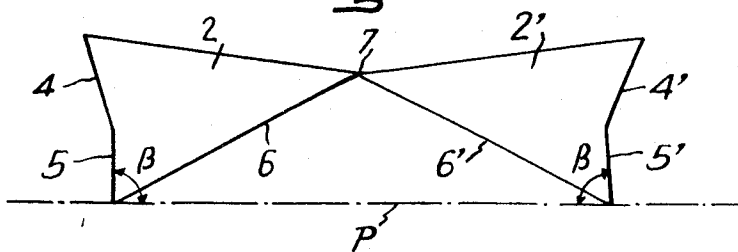

Fig. 6

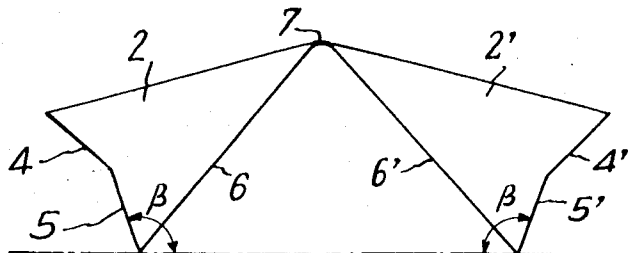
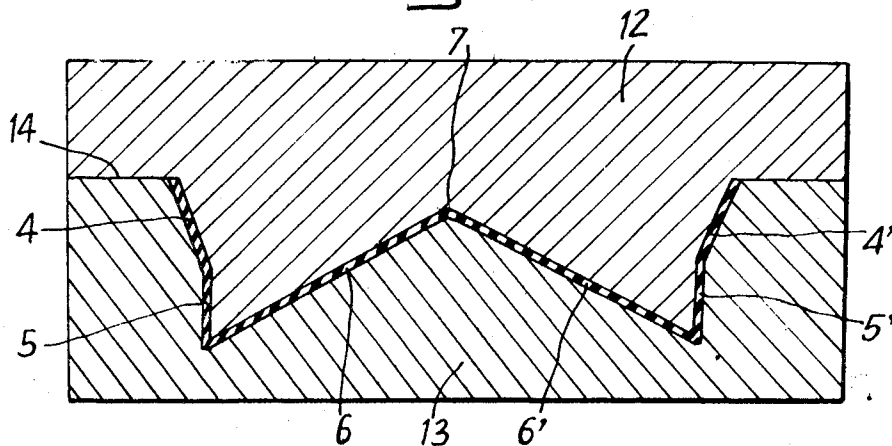

Fig. 7



1

2

3,606,919

CONTAINER

Roger Joerger and Jean-Claude Joerger, Paris, France,

assignors to Joerger & Fils, Paris, France

Filed July 25, 1969, Ser. No. 844,804

Claims priority, application France, Aug. 9, 1968,

162,436

Int. Cl. B65d 1/26

U.S. Cl. 150—5

3 Claims

## ABSTRACT OF THE DISCLOSURE

This invention relates to a container and, more particularly, to a container having two hinged portions which can be held in closed condition by the interengagement of locking walls associated with the portions.

## BACKGROUND OF THE INVENTION

One kind of container which is widely used is a cardboard box closed by means of an extension of a side or flap that is bent in such a way that it can be inserted into the box. This method of closure, however, is not perfect because the flap is held in position only by friction, which is not always sufficient. In other systems, in order that the flap may be kept in position more firmly, opening the box is made more difficult, and often it is necessary to use a knife-blade or one's fingernails to lift the flap; ultimately, it causes the container to deteriorate. As far as plastic cases are concerned, it has so far not been possible to produce a practical system of flap closure, and the types used at present either include a separate cover, lid, or top, a pressure-type arrangement, or a zip-fastener-type closure. These and other difficulties experienced with the prior art devices have been obviated in a novel manner by the present invention.

It is, therefore, an outstanding object of the invention to provide a container having a simple, yet effective, locking means.

Another object of this invention is the provision of a container adapted to be formed in one piece of plastic material.

A further object of the present invention is the provision of a container having a closure construction that has no complex locking mechanism that is difficult to operate and readily deteriorates.

With these and other objects in view, as will be apparent to those skilled in the art, the invention resides in the combination of parts set forth in the specification and covered by the claims appended hereto.

## SUMMARY OF THE INVENTION

In general, the invention relates to a container consisting of a first portion and a second portion. Each portion has a main wall and a locking wall extending from the main wall. The main walls are joined together along a hinge line which is a substantial distance from the locking walls. Each locking wall has two parts that extend at an angle to one another, so that the first portion and the second portion can be rotated about the hinge line until the locking walls nest together.

## BRIEF DESCRIPTION OF THE DRAWINGS

The character of the invention, however, may be best understood by reference to one of its structural forms, as illustrated by the accompanying drawings, in which:

FIG. 1 is a perspective view in open condition of a container embodying the principles of the present invention,

FIG. 2 is a perspective view of the container in closed condition,

FIG. 3 is a perspective view of a modified form of the container in closed condition,

FIG. 4 is an end view of the container of FIG. 1,

FIG. 5 is an end view of the container showing a form in which it is manufactured,

FIG. 6 is an end view of the container showing another form in which it can be manufactured, and

FIG. 7 is a vertical sectional view of mold used in making the container, showing the container in place in the cavity.

## DESCRIPTION OF THE PREFERRED EMBODIMENT

As shown in FIG. 1, the container (which is shown as a box for eyeglasses) comprises two prismatic components or portions, open at one side, having main walls 6, 6'. Each of these portions has side walls 2, 2' and 3, 3', and terminates in a longitudinal dihedral locking wall 1, 1'. The dihedral or locking wall 1 is formed by two parts 4 and 5 which form between them an angle  $\alpha$ . In the same way, the dihedral locking wall 1' comprises parts 4' and 5', one inclined towards the other at the same angle  $\alpha$ . The surfaces 6 and 6' of the base, common for both prisms, are connected along a hinge line 7. A boss 8 is provided to be used as a support for the bridge-piece connecting the two lenses of the spectacles.

To close the case, it is only necessary to pivot the left prismatic portion, following the arrows, around the hinge line 7, and to push dihedral 1 into dihedral 1'. In this way, the two dihedrons are nested or superimposed one onto the other, i.e., 4' on 5, and 5' on 4, as shown in FIG. 2, which represents the closed container. It will be understood that to achieve such superimposing, a certain pressure must be exerted, because the upper edge of 1 is at a certain distance from the hinge line 7, and this is a little greater than the distance between the base of the angle  $\alpha$  and the hinge line. Consequently, when the edge of 1, i.e., the outside extremity of 4, has been brought to the underside of 5' (FIG. 2), the container is, so to say, locked by the cavity created by the angle  $\alpha$ .

As another eventuality, the case may be designed in such a way that the prismatic part 1, on the left, comes to encase the right-hand part 1', instead of being inserted into it, as indicated above. The result of superimposing 4 on 5' is the same as 5 on 4'. For this, it is sufficient to have a small dimensional difference between the two prismatic parts.

Another practical embodiment of the invention is shown in FIG. 3 wherein the same principle will be found, but the single hinge line 7 is replaced by a side 11 which is wider and gives to the assembly a polygonal shape having an almost rectangular cross-section. The side 1 may pivot around the hinge line 10 or 9, or around both, at the same time.

To understand the manufacturing process by molding a container according to the invention, it will be useful to compare FIGS. 4 and 5. The end view shown in FIG. 4, which corresponds to the open container as shown in FIG. 1, could give the impression that molding is not possible because of recessed areas limited, respectively, by the inclined sides 5 and 5' of the dihedrons. But, according to this invention, this problem is solved by making the mold of such shape that the container at the time of molding is open to such a degree that the recessed areas are no longer present. To achieve this (as shown in FIG. 5), it is necessary for each of the dihedral sides 5 and 5' to make an angle  $\beta$ , which is not less than 90° with a plane P connecting the extreme ridges of the sides 5, 5'. It is understood that the angle  $\beta$  is measured on the inside of the assembly, i.e., in relation to the imaginary plane P which closes the space 6-7-6'.

FIG. 6 shows, as an example, a container for which angle  $\beta$  is equal approximately  $110^\circ$ ; this angle may be even larger, but the method can be applied starting from  $\beta=90^\circ$ , as shown in FIGS. 5 and 7.

FIG. 7 shows the cross-section of a mold designed according to this invention in order to produce the container shown in FIG. 1; the opening angle during molding will be as shown in FIG. 5. It may be seen that, with this arrangement, the two parts of the mold 12 and 13 fit together perfectly, and they may be easily separated after molding. Withdrawal of the container 4-5-6-7-6'-5'-4' from the mold cavity may be carried out in the usual manner. The necessary condition for this is to ensure that sides 4 and 5 of the left-hand dihedral form an angle exceeding  $90^\circ$  with the parting surface 14 between two parts 12 and 13 of the mold. Also, parts 4' and 5' should be no less than  $90^\circ$  in relation to the plane 14. This condition is equivalent to that condition according to which the angle  $\beta$  (FIG. 5) should be equal to  $90^\circ$  or exceed  $90^\circ$ .

That which has been said about making a container whose dihedral angle  $\alpha$  is convex towards the inside, is also valid for dihedrons which are convex towards the outside. In that case, the fact that the angle  $\beta$  must be greater than  $90^\circ$  applies to the sides 4 and 4', instead of 5, 5'.

It is desirable that the container be formed of a material such as plastic that will not easily break, i.e., is not brittle; on the other hand, the material should have a degree of resilience to permit the locking sides to snap together adequately.

The present invention satisfies the deficiencies of the prior art. It is a new system for closing boxes, cases, or shaped packings, without requiring another separate or additional component, or cutting off a part of a case. The container made according to this invention can be closed by the simple pivoting of one of its parts in relation to the other, providing a fitting which gives excellent closure and which does not deteriorate. In addition, the subject of this invention has the advantage of being extremely simple, and it can be manufactured in one single operation, if produced by a molding process.

It should be noted that the main advantage of this invention consists in the fact that the closure is excellent, and is obtained by the tension (pressure) which has to be applied to separate the two superimposed dihedrons. As a matter of fact, to close or to open a case or box made according to this invention, it is necessary to pass the edge of one of the dihedral sides over the edge of the other dihedral side. By making use of this invention, it is easy to alter the dihedral angle in order to obtain the result required, i.e., according to the nature of the material used (i.e., its elasticity), the thickness of the sides, the box size, and according to the predetermined value of the force required for closing.

According to the invention, the dihedral of the two parts of the side is an obtuse angle; it may, according to requirements, vary between  $100^\circ$  and  $170^\circ$ ; its most generally used values are between  $130^\circ$  and  $160^\circ$ . The dihedral parts of the case may have their convex surfaces directed towards the inside of the case, or towards the outside.

It is obvious that the other parts of a container made according to this invention may have any shape as desired; in fact, as a whole, the case may have the shape of a prism, a parallelepiped, a sphere, a hemisphere, an ellipsoid. It may also incorporate several parts having different shapes. Also, it may have embossings or other reliefs, raised parts, or cavities, of any sort, which might be provided in the sides of the walls, or even, should it be required, in the dihedral parts themselves. It is also

obvious that, when a case is produced by molding, the various shapes mentioned above are or may be such that it is possible to withdraw them from the molds without difficulty.

Although this invention may be most useful for the production of boxes or cases of a type to be completely closed, it may also be applied for packing purposes, by way of enclosing or enveloping only one part of the object; such packings may have the shape of strips or sleeves surrounding the object to be packed or wrapped, which may protrude at one or on two ends.

It is obvious that minor changes may be made in the form and construction of the invention without departing from the material spirit thereof. It is not, however, desired to confine the invention to the exact form herein shown and described, but it is desired to include all such as properly come within the scope claimed.

The invention having been thus described, what is claimed as new and desired to secure by Letters Patent is:

1. A container formed of flexible sheet material, comprising

- (a) a first rectangular main wall,
- (b) a second rectangular main wall identical to the first main wall,
- (c) a hinge joining an elongated edge of the first main wall to an elongated edge of the second main wall,
- (d) a generally triangular end wall integrally formed with each end edge of the first and second main walls, the end walls being identical and each being arranged to have one apex located at the said elongated edge of its respective main wall,
- (e) a first side wall joining and integrally formed with the other elongated edge of the first main wall and with the sides opposite the said apices of the two end walls associated with the first main wall, the first side wall consisting of two rectangular portions integrally formed with and lying at an obtuse angle to each other, the apex of the angle extending parallel to the said other elongated edge of the first main wall with the interior of the angle facing away in a given direction relative to the said hinge, and
- (f) a second side wall joining and integrally formed with the other elongated edge of the second main wall and with the sides opposite the said apices of the two end walls associated with the second main wall, the second side wall consisting of two rectangular portions integrally formed with and lying at an obtuse angle to each other, the apex of the angle extending parallel to the said other elongated edge of the second wall with the interior of the angle facing away from the said direction.

2. A container as recited in claim 1, wherein the hinge is a strip of flexible sheet material integral with the first and second main walls.

3. A container as recited in claim 1, wherein the said direction is away from the hinge.

#### References Cited

##### UNITED STATES PATENTS

1,851,518	3/1932	McGovern	229—44
2,852,054	9/1958	Motley	150—5
3,043,354	7/1962	Fitzgerald	150—5
3,397,774	8/1968	Tjaden	220—60X
3,412,890	11/1968	Rich	220—60X

DONALD F. NORTON, Primary Examiner

U.S. Cl. X.R.

220—31S, 60R; 229—44R, 45