



- (51) **International Patent Classification:**  
*F04B 43/04* (2006.01)    *A61M 5/142* (2006.01)
- (21) **International Application Number:**  
PCT/SE2009/050514
- (22) **International Filing Date:**  
8 May 2009 (08.05.2009)
- (25) **Filing Language:** English
- (26) **Publication Language:** English
- (71) **Applicant (for all designated States except US):**  
XAVITECH AB [SE/SE]; Järnvägsgatan 2, S-871 45  
Härnösand (SE).
- (72) **Inventor; and**
- (75) **Inventor/Applicant (for US only): GRIP, Jonathan** [SE/  
SE]; Johan Nybergsväg 6, S-871 33 Härnösand (SE).
- (74) **Agents: OLSSON, Jan et al.;** Bjerkéns Patentbyrå KB,  
Box 1274, S-801 37 Gävle (SE).
- (81) **Designated States (unless otherwise indicated, for every  
kind of national protection available):** AE, AG, AL, AM,

AO, AT, AU, AZ, BA, BB, BG, BH, BR, BW, BY, BZ, CA, CH, CN, CO, CR, CU, CZ, DE, DK, DM, DO, DZ, EC, EE, EG, ES, FI, GB, GD, GE, GH, GM, GT, HN, HR, HU, ID, IL, IN, IS, JP, KE, KG, KM, KN, KP, KR, KZ, LA, LC, LK, LR, LS, LT, LU, LY, MA, MD, ME, MG, MK, MN, MW, MX, MY, MZ, NA, NG, NI, NO, NZ, OM, PG, PH, PL, PT, RO, RS, RU, SC, SD, SE, SG, SK, SL, SM, ST, SV, SY, TJ, TM, TN, TR, TT, TZ, UA, UG, US, UZ, VC, VN, ZA, ZM, ZW.

- (84) **Designated States (unless otherwise indicated, for every  
kind of regional protection available):** ARIPO (BW, GH, GM, KE, LS, MW, MZ, NA, SD, SL, SZ, TZ, UG, ZM, ZW), Eurasian (AM, AZ, BY, KG, KZ, MD, RU, TJ, TM), European (AT, BE, BG, CH, CY, CZ, DE, DK, EE, ES, FI, FR, GB, GR, HR, HU, IE, IS, IT, LT, LU, LV, MC, MK, MT, NL, NO, PL, PT, RO, SE, SI, SK, TR), OAPI (BF, BJ, CF, CG, CI, CM, GA, GN, GQ, GW, ML, MR, NE, SN, TD, TG).

**Published:**

— with international search report (Art. 21(3))

(54) **Title:** A MEMBRANE PUMP

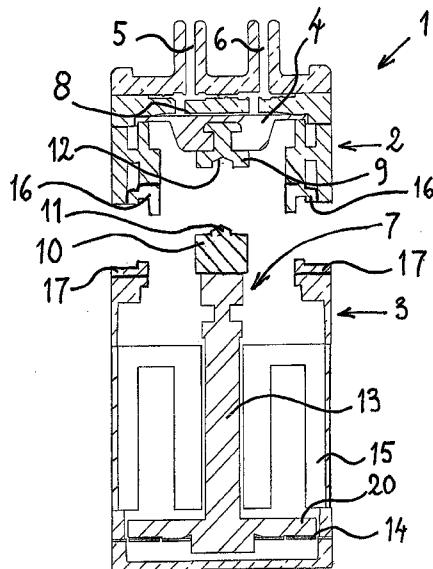

Fig 1

(57) **Abstract:** A membrane pump (1) comprising, a pump housing, a membrane (4), which is mounted to the pump housing and delimits a pump chamber (8) inside the pump housing, an inlet (5) and an outlet (6) for feeding medium into and out from the pump chamber, and actuating means (7) for moving the membrane back and forth between a first and a second position. The membrane, the inlet and the outlet are arranged in a first part (2) of the pump housing, the first part being detachably connected to a second part (3) of the pump housing, in which the actuating means is arranged. The membrane is detachably connected to the actuating means by means of a magnetic coupling, which comprises a first magnetic coupling part (9) fixed to the membrane and a corresponding second magnetic coupling part (10) fixed to the actuating means.

## A membrane pump

### FIELD OF THE INVENTION AND PRIOR ART

- 5 The invention relates to a membrane pump according to the preamble of claim 1.

10 Pumps that are used for driving a fluid in a circuit are found in a large variety of forms and sizes and are used in many different applications, from large industry pumps to small pumps for medical purposes. In some application it is desired to keep the circuit strictly clean during pumping, which may imply that parts that are in contact with the fluid to be pumped have to be replaceable and/or cleanable.

15

In medical applications it is usually very important that all parts of the apparatus that are in contact with the fluid to be pumped are kept in a sterilized condition. Pumps are usually expensive parts and costly to exchange, and nowadays this is solved by providing the apparatus with a peristaltic pump, provided with a gear, which never is in direct contact with the fluid. Instead, the gear of the peristaltic pump engages and compresses a plastic tube which leads the fluid in a driving direction. The gear rotates while the cogs of the gear are sliding along said tube in the driving direction. Portions of the fluid in the tube are thereby transported by the sliding cogs in said direction. When parts of the apparatus that are in contact with the fluid the only thing that needs to be exchanged is the plastic tube. Since the peristaltic pump works by sliding the cogs of its gear along a plastic tube the friction created between the plastic tube and the cogs demands a relatively strong motor of the peristaltic pump, which of course means that the peristaltic pump has relatively high energy consumption. Peristaltic pumps are used for numerous medical applications and the high energy consumption may be acceptable on large apparatuses in for

20

25

30

35

instance hospitals, but for portable systems there is a need to significantly lower the energy consumption.

5 In some medical applications fluids are driven in circuits by membrane pumps. A membrane pump is relatively expensive so it is desirable to provide an arrangement in which only the parts of the membrane pump that have been in contact with the fluid are exchanged.

10 EP 0333305 A2 discloses a membrane pump which is provided with an exchangeable pump chamber in the form of a cassette. An actuator is used for driving the membrane back and forth and the cassette is screwed onto a threaded part of the actuator.

15 EP 0398583 A2 discloses a membrane pump which is provided with an exchangeable pump chamber. The membrane comprises piezoelectric driving means which also are exchanged when the pump chamber is exchanged.

20 US 5816779 A discloses a disposable pumping cassette, which has a membrane to be actuated by an actuator. The actuator abuts the membrane and is arranged for compressing a pump chamber by pressing said membrane in one direction. The decompression of the pump chamber is accomplished by the  
25 intrinsic flexibility of the membrane, which causes the membrane to return to its initial position which restores the pump chamber into its decompressed state.

## SUMMARY OF THE INVENTION

30

The object of the present invention is to provide a new and favourable membrane pump with an exchangeable pump chamber.

35 This object is according to the invention achieved by means of a membrane pump having the features defined in claim 1, wherein

the membrane pump comprises a pump housing, a membrane, which is mounted to the pump housing and delimits a pump chamber inside the pump housing, an inlet for feeding medium into the pump chamber, the inlet having a first non-return valve  
5 connected thereto, an outlet for discharging medium from the pump chamber, the outlet having a second non-return valve connected thereto, and actuating means for moving the membrane back and forth between a first position and a second position. The membrane, the inlet and the outlet are arranged in  
10 a first part of the pump housing, the first part being detachably connected to a second part of the pump housing, in which the actuating means is arranged. The membrane is detachably connected to the actuating means by means of a magnetic coupling, which comprises a first magnetic coupling part fixed to  
15 the membrane and a corresponding second magnetic coupling part fixed to the actuating means.

When using the membrane pump of the invention for pumping a medium, all the parts that are in contact with the medium are  
20 arranged in the first part of the pump housing. The first part is detachable from the second part which allows the first part to be exchanged if necessary. During pumping, the membrane needs to be actuated by the actuating means in order to oscillate and thereby provide the pumping force. In the inventive membrane  
25 pump the membrane is firmly connected to the actuating means by a magnetic coupling, and this allows for the first part of the pump housing to be swiftly exchanged by detaching it from the second part of the pump housing. The membranes of small membrane pumps are usually made of relatively soft materials,  
30 such as polymers, and if the membrane of a small membrane pump is connected to the actuating means by a screwed coupling as disclosed in EP 0333305 A2, the screwing could damage the membrane or twist it into an unwanted shape. The magnetic coupling in the inventive membrane pump provides a  
35 firm connection between the membrane and the actuator without the need of screwing any part onto another part, which ensures

that the membrane is kept intact after mounting the first part of the pump housing to the second part of the pump housing. During pumping with a membrane pump, for instance for driving a fluid in a circuit, it is important that significant driving forces  
5 can be applied by the actuating means to the membrane in both the first and the second direction. When using a membrane pump as disclosed in US 5816779 A the driving force is only applied in one direction, which significantly impair the pumping ability of the membrane pump.

10

According to one embodiment of the invention one of the first and the second magnetic coupling parts comprises a permanent magnet and the other magnetic coupling part comprises a ferromagnetic material. A permanent magnet attracts a  
15 ferromagnetic material which ensures that the magnetic coupling provides a firm connection between the membrane and the actuating means.

According to another embodiment of the invention the first  
20 magnetic coupling part comprises a ferromagnetic material and the second magnetic coupling part comprises a permanent magnet. A permanent magnet is usually more expensive than a ferromagnetic material and since the first part of the pump housing is the part of the pump housing to be exchanged it is  
25 advantageous if the first magnetic coupling part comprises the inexpensive ferromagnetic material and the second magnetic coupling part, which is not to be exchanged, comprises the more expensive permanent magnet.

30 According to another embodiment of the invention one of the first and second magnetic coupling parts comprises a protrusion configured for insertion into a corresponding recess comprised in the other magnetic coupling part. If the magnetic coupling comprises a protrusion and a corresponding recess, movements  
35 of the first and second coupling parts in relation to each other

are significantly suppressed when they are connected to each other.

5 According to another embodiment of the invention the actuating means comprises a shaft, which at one end is provided with said second magnetic coupling part. The actuating means is driven for instance by a spring and an electromagnet or by two electromagnets and it is advantageous to have a part of the actuating means comprising a shaft affected by said spring  
10 and/or electromagnet/electromagnets. The shaft preferably moves back and forth in its longitudinal direction during pumping and is at one end connected to the membrane by said magnetic coupling. When the shaft moves, the membrane moves in the same direction as the shaft.

15 According to another embodiment of the invention the first part of the pump housing comprises guiding means configured for radially guiding the shaft so as to guide said protrusion into said recess. The guiding means can for instance comprise an annular  
20 opening configured for receiving the shaft of the actuating means when the first part of the pump housing is connected to the second part of the pump housing. The guiding means facilitates a correct connection of the membrane to the actuating means. This is important since pumping with the inventive pump  
25 is dependent upon a firm connection between the membrane and the actuating means. If the membrane is incorrectly connected to the actuating means there is a risk for interruption in the service during pumping.

30 According to another embodiment of the invention the second part of the pump housing comprises guiding means configured for restricting radial movement of the shaft in said second part of the pump housing. Radial movement of the shaft in the second part of the pump housing may damage said shaft.

35

According to another embodiment of the invention the first part of the pump housing is detachably connected to the second part of the pump housing by means of a coupling, which comprises a first coupling part fixed to the first part of the pump housing and  
5 a second coupling part fixed to the second part of the pump housing.

According to another embodiment of the invention the coupling of the pump housing is a snap coupling. A snap coupling  
10 provides a quick and reliable connection between the first part and the second part of the pump housing.

According to another embodiment of the invention the coupling of the pump housing is a magnetic coupling. A magnetic  
15 coupling provides a quick and reliable connection between the first part and the second part of the pump housing and it does not deteriorate over time.

According to another embodiment of the invention one of the  
20 first and second coupling parts comprises a permanent magnet and the other coupling part comprising a ferromagnetic material. A permanent magnet attracts a ferromagnetic material which ensures that the magnetic coupling provides a firm connection between the first part and the second part of the pump housing.  
25 The magnetic coupling can of course instead comprise two permanent magnets, one permanent magnet comprised in the first part and one in the other part.

According to another embodiment of the invention the first  
30 coupling part comprises a ferromagnetic material and the second coupling part comprises a permanent magnet. A permanent magnet is usually more expensive than a ferromagnetic material and since the first part of the pump housing is the part of the pump housing to be exchanged it is  
35 advantageous if the first part of the pump housing comprises the inexpensive ferromagnetic material and the second part of the

pump housing, which is not to be exchanged, comprises the more expensive permanent magnet.

Other advantages and advantageous features of the invention will appear from the dependent claims and the subsequent description.

#### BRIEF DESCRIPTION OF THE DRAWINGS

With reference to the appended drawings, below follows a specific description of embodiments of the invention cited as examples.

In the drawings:

15

Fig 1 shows a membrane pump according to an embodiment of the invention with a first part of the pump housing separated from a second part of the pump housing,

20

Fig 2 shows the membrane pump of Fig 1 with the two parts of the pump housing connected to each other, and

Fig 3 shows a membrane pump according to another embodiment of the invention

25

#### DETAILED DESCRIPTION OF PREFERRED EMBODIMENTS OF THE INVENTION

Explained herein are preferred embodiments of the invention, describing the membrane pump of the invention. The invention may, however, be embodied in many different forms and should not be construed as being limited to the exemplary embodiments set forth herein; rather, these embodiments are provided so that this disclosure will be thorough and complete, and will fully convey the concept of the invention to those skilled in the art.

35



A membrane pump 1 according to the invention is shown in Figs 1 and 2. In Fig 1 the membrane pump 1 is separated into two parts 2, 3 and in Fig 2 the membrane pump is shown in its assembled form in which the two separated parts shown in Fig 1 are assembled. The membrane pump 1 comprises a pump housing which comprises two parts 2,3, a first part 2 in which a membrane 4, an inlet 5 and an outlet 6 are arranged and a second part 3 in which actuating means 7 is arranged. The membrane 4 is mounted to the first part 2 of the pump housing and delimits a pump chamber 8 inside said first part 2. The inlet 5, which has a first non-return valve (not shown) connected thereto, is arranged for feeding medium into the pump chamber 8, and the outlet 6, which has a second non-return valve (not shown) connected thereto, is arranged for discharging medium from the pump chamber 8. The actuating means 7 is configured for moving the membrane 4 back and forth between a first and a second position when the membrane pump 1 is in its assembled form and in use. The membrane 4 is configured to be detachably connected to the actuating means 7 by means of a magnetic coupling, which comprises a first magnetic coupling part 9 fixed to the membrane 4 and a corresponding second magnetic coupling part 10 fixed to the actuating means 7. The magnetic coupling can be achieved by having one of the first 9 and the second 10 magnetic coupling parts comprising a permanent magnet and the other magnetic coupling part comprising a ferromagnetic material. The magnetic coupling can of course instead comprise two permanent magnets, one permanent magnet comprised in the first magnetic coupling part 9 and one in the second magnetic coupling part 10. An electromagnetic coupling is of course also possible. Preferably, the first magnetic coupling part 9 comprises a ferromagnetic material and the second magnetic coupling part 10 comprises a permanent magnet. The second magnetic coupling part 10 also comprises a protrusion 11 configured for insertion into a corresponding recess 12 comprised in the first magnetic coupling part 9. Of course a protrusion instead can be

comprised in the first magnetic coupling part 9 for insertion into a corresponding recess comprised in the second magnetic coupling part 10. The actuating means 7 comprises a shaft 13, which at one end is provided with said second magnetic coupling part 10. To move the membrane 4 back and forth the shaft 13 of the actuating means 7 is driven by a spring, preferably a flat spring 14, longitudinally in one direction and an electromagnet 15 longitudinally in the opposite direction. The spring 13 can of course be replaced by a second electromagnet.

10

The first part 2 of the pump housing is detachably connected to the second part 3 of the pump housing by means of a coupling, which coupling comprises a first coupling part 16 fixed to the first part 2 of the pump housing and a second coupling part 17 fixed to the second part 3 of the pump housing. The coupling of the pump housing shown in Figs 1 and 2 is a magnetic coupling, wherein one of the first 16 and second 17 coupling parts comprises a permanent magnet and the other coupling part comprises a ferromagnetic material. The magnetic coupling can of course instead comprise two permanent magnets, one permanent magnet comprised in the first coupling part 16 and one in the second coupling part 17. Preferably the first coupling part 16 comprises a ferromagnetic material and the second coupling part 17 comprises a permanent magnet. The coupling of the pump housing can also be a snap coupling or any other coupling suitable for the purpose of connecting the first 2 and the second 3 parts of the pump housing to each other.

The first part 2 of the pump housing is exchangeable and in order to detach it from the second part 3 of the pump housing said first part 2 is moved in the longitudinal direction of said shaft 13 away from the second part 3 of the pump housing, whereby the first magnetic coupling part 9 is detached from the second magnetic coupling part 10 and the first coupling part 16 of the pump housing is detached from the second coupling part 17 of the pump housing. If the coupling of the pump housing is a

35

5 snap coupling or any other coupling, other operations may be needed for detaching the first part 2 of the pump housing from the second part 3 of the pump housing. To attach the first part 2 of the pump housing to the second part 3 of the pump housing the two parts 2, 3 of the pump housing are moved towards each other so as to allow the corresponding coupling parts to come into engagement with each other.

10 In Fig 3 it is shown a membrane pump 1 according to another embodiment of the invention. The membrane pump 1 shown in Fig 1 resembles the membrane pumps shown in Fig 2 and Fig 3 but here the first part 2 of the pump housing comprises guiding means 18 configured for radially guiding the shaft 13 of the actuating means 7 so as to guide the protrusion 11 of the  
15 second magnetic coupling part 10 into the recess 12 of the first magnetic coupling part 9 when the first part 2 of the pump housing is connected to the second part 3 of the pump housing. The guiding means 18 of the first part 2 of the pump housing has a central opening configured for receiving said shaft 13 and/or the second magnetic coupling part 10. The second part 3  
20 of the pump housing comprises guiding means 19 configured for restricting radial movement of the shaft 13 in said second part 3 of the pump housing. The guiding means 19 of the second part 3 of the pump housing is especially important when the first part 2 of the pump housing is detached, due to the risk for damaging the shaft 13 by having it hit the electromagnet 15 if said guiding means 19 is absent. The guiding means 19 of the second part 3 of the pump housing has a central opening configured for receiving said shaft 13.

30 During pumping using the membrane pumps 1 shown in Figs 1-3, in a first phase the flat spring 14 affects the shaft 13, and thereby the membrane 4, with a force pulling the membrane 4 in a direction away from the pump chamber 8, whereby the volume  
35 of the pump chamber 8 expands and the first non-return valve is opened so as to allow medium to flow into the pump chamber 8

through the inlet 5. During this first phase, the membrane 4 is moved under the action of the spring 14 from a first end position to a second end position. In a second phase the electromagnet 15 is activated, whereby the electromagnet 15 attracts a protruding magnetic part 20 of the shaft 13 and the shaft 13 is pulled in a direction towards the pump chamber 8, and the membrane 4 consequently also moves towards the pump chamber 8. The pump chamber 8 is thereby contracted and the medium flows out from the pump chamber 8 through the second non-return valve and the outlet 6. During this second phase, the membrane 4 is moved under the action of the electromagnet 15 and against the action of the spring 14 from the second end position to the first end position. Of course another electromagnet can replace the spring 14 and provide the force for pulling the membrane 4 away from the pump chamber 8. If the spring 14 is replaced by an electromagnet, the other electromagnet 15 can be replaced by another spring, which provides the force for pushing the membrane 4 towards the pump chamber 8.

20 The invention is of course not in any way limited to the embodiments described above. On the contrary, several possibilities to modifications thereof should be apparent to a person skilled in the art without departing from the basic idea of the invention as defined in the appended claims.

## Claims

1. A membrane pump (1) comprising:
- a pump housing,
  - 5 - a membrane (4), which is mounted to the pump housing and delimits a pump chamber (8) inside the pump housing,
  - an inlet (5) for feeding medium into the pump chamber (8), the inlet (5) having a first non-return valve connected thereto,
  - 10 - an outlet (6) for discharging medium from the pump chamber (8), the outlet (6) having a second non-return valve connected thereto, and
  - actuating means (7) for moving the membrane (4) back and forth between a first and a second position,
  - 15 **characterized in** that the membrane (4), the inlet (5) and the outlet (6) are arranged in a first part (2) of the pump housing, the first part (2) being detachably connected to a second part (3) of the pump housing, in which the actuating means (7) is arranged, and that the membrane
  - 20 (4) is detachably connected to the actuating means (7) by means of a magnetic coupling, which comprises a first magnetic coupling part (9) fixed to the membrane (4) and a corresponding second magnetic coupling part (10) fixed to the actuating means (7).
  - 25
2. A membrane pump (1) according to claim 1, **characterized in** that one of the first (9) and the second (10) magnetic coupling parts comprises a permanent magnet and the other magnetic coupling part comprises a ferromagnetic material.
- 30
3. A membrane pump (1) according to claim 2, **characterized in** that the first magnetic coupling part (9) comprises a ferromagnetic material and that the second magnetic coupling part (10) comprises a permanent magnet.
- 35

4. A membrane pump (1) according to any of the preceding claims, **characterized in** that one of the first (9) and second (10) magnetic coupling parts comprises a protrusion (11) configured for insertion into a corresponding recess (12) comprised in the other magnetic coupling part.
- 5
5. A membrane pump (1) according to claim 4, **characterized in** that the second magnetic coupling part (10) comprises said protrusion (11) configured for insertion into said corresponding recess (12) comprised in the first magnetic coupling part (9).
- 10
6. A membrane pump (1) according to any of the preceding claims, **characterized in** that the actuating means (7) comprises a shaft (13), which at one end is provided with said second magnetic coupling part (10).
- 15
7. A membrane pump (1) according to claim 6 in combination with claim 4 or 5, **characterized in** that the first part (2) of the pump housing comprises guiding means (18) configured for radially guiding the shaft (13) so as to guide said protrusion (11) into said recess (12) when the first part (2) of the pump housing is connected to the second part (3) of the pump housing.
- 20
- 25
8. A membrane pump (1) according to claim 6 or 7, **characterized in** that the second part (3) of the pump housing comprises guiding means (19) configured for restricting radial movement of the shaft (13) in said second part (3) of the pump housing.
- 30
9. A membrane pump (1) according to any of claims 1-8, **characterized in** that the first part (2) of the pump housing is detachably connected to the second part (3) of the pump housing by means of a coupling, which comprises a first
- 35

coupling part (16) fixed to the first part (2) of the pump housing and a second coupling part (17) fixed to the second part (3) of the pump housing.

- 5 10. A membrane pump (1) according to claim 9, **characterized in** that the coupling of the pump housing is a snap coupling.
- 10 11. A membrane pump (1) according to claim 9, **characterized in** that the coupling of the pump housing is a magnetic coupling.
- 15 12. A membrane pump (1) according to claim 11, **characterized in** that one of the first (16) and second (17) coupling parts comprises a permanent magnet and the other coupling part comprises a ferromagnetic material.
- 20 13. A membrane pump (1) according to claim 12, **characterized in** that the first coupling part (16) comprises a ferromagnetic material and the second coupling part (17) comprises a permanent magnet.







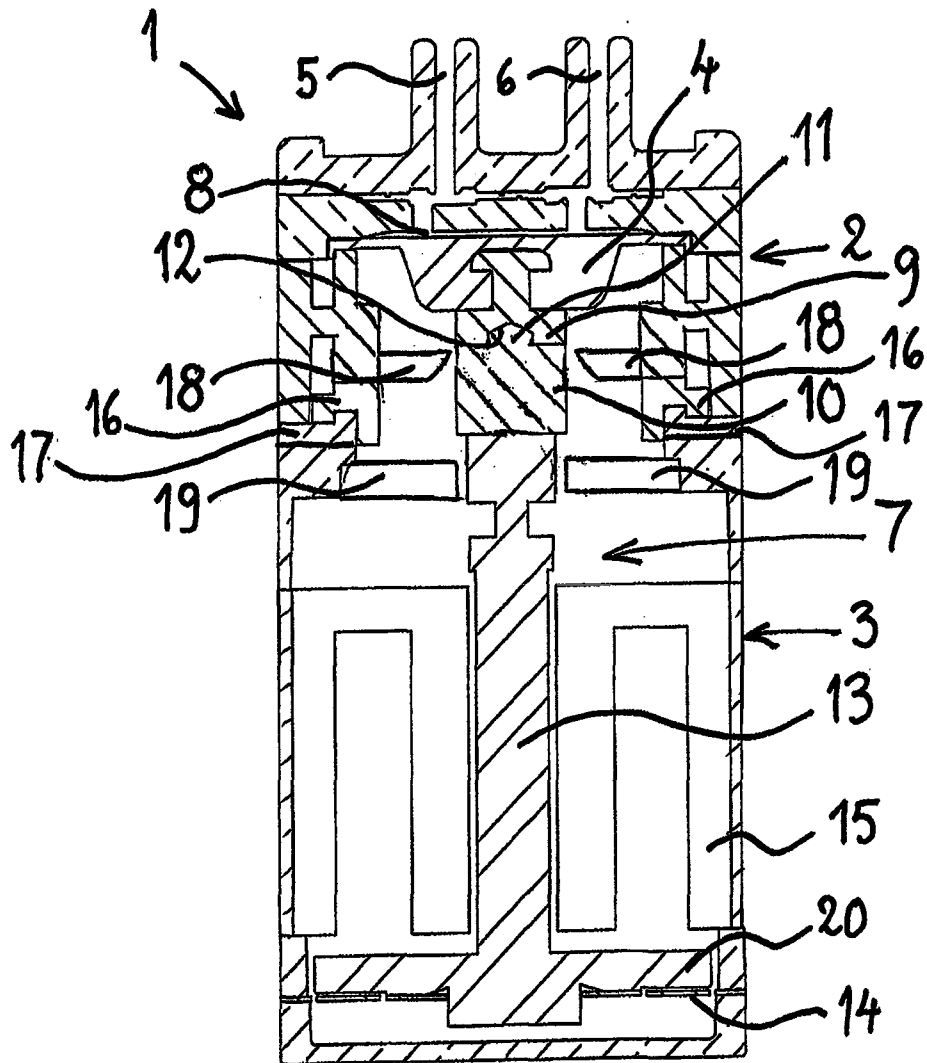

Fig 3

INTERNATIONAL SEARCH REPORT

International application No.

PCT/SE2009/050514

A. CLASSIFICATION OF SUBJECT MATTER

IPC: see extra sheet

According to International Patent Classification (IPC) or to both national classification and IPC

B. FIELDS SEARCHED

Minimum documentation searched (classification system followed by classification symbols)

IPC: A61M, F04B

Documentation searched other than minimum documentation to the extent that such documents are included in the fields searched

SE,DK,FI,NO classes as above

Electronic data base consulted during the international search (name of data base and, where practicable, search terms used)

EPO-INTERNAL, WPI DATA, PAJ

C. DOCUMENTS CONSIDERED TO BE RELEVANT

Category*	Citation of document, with indication, where appropriate, of the relevant passages	Relevant to claim No.
A	EP 0333305 B1 (CRITIKON, INC.), 28 July 1993 (28.07.1993), figures 12,13, pos. 45 --	1-13
A	EP 0398583 B1 (BESPAK PLC), 8 April 1994 (08.04.1994), figure 1, claim 1, pos. 10 --	1-13
A	US 5816779 A (LAWLESS ET AL), 6 October 1998 (06.10.1998), figures 8,9, abstract -- -----	1-13

Further documents are listed in the continuation of Box C.

See patent family annex.

\* Special categories of cited documents:

"A" document defining the general state of the art which is not considered to be of particular relevance

"E" earlier application or patent but published on or after the international filing date

"L" document which may throw doubts on priority claim(s) or which is cited to establish the publication date of another citation or other special reason (as specified)

"O" document referring to an oral disclosure, use, exhibition or other means

"P" document published prior to the international filing date but later than the priority date claimed

"T" later document published after the international filing date or priority date and not in conflict with the application but cited to understand the principle or theory underlying the invention

"X" document of particular relevance: the claimed invention cannot be considered novel or cannot be considered to involve an inventive step when the document is taken alone

"Y" document of particular relevance: the claimed invention cannot be considered to involve an inventive step when the document is combined with one or more other such documents, such combination being obvious to a person skilled in the art

"&" document member of the same patent family

Date of the actual completion of the international search

3 November 2009

Date of mailing of the international search report

03-11-2009

Name and mailing address of the ISA/  
Swedish Patent Office  
Box 5055, S-102 42 STOCKHOLM  
Facsimile No. +46 8 666 02 86

Authorized officer

Lena Nilsson / JA A  
Telephone No. +46 8 782 25 00

**International patent classification (IPC)****F04B 43/04** (2006.01)**A61M 5/142** (2006.01)**Download your patent documents at [www.prv.se](http://www.prv.se)**

The cited patent documents can be downloaded:

- From "Cited documents" found under our online services at [www.prv.se](http://www.prv.se) (English version)
- From "Anförda dokument" found under "e-tjänster" at [www.prv.se](http://www.prv.se) (Swedish version)

Use the application number as username. The password is **XBXEVSUSRO**.

Paper copies can be ordered at a cost of 50 SEK per copy from PRV InterPat (telephone number 08-782 28 85).

Cited literature, if any, will be enclosed in paper form.

## INTERNATIONAL SEARCH REPORT

Information on patent family members

International application No.

PCT/SE2009/050514

EP	0333305	B1	28/07/1993	AT	91907	T	15/08/1993
EP	0398583	B1	08/04/1994	AR	242718	A	31/05/1993
				AU	635262	B	18/03/1993
				AU	5486590	A	15/11/1990
				BR	9002191	A	13/08/1991
				CA	2016595	A,C	25/08/1998
				CN	1022852	C	24/11/1993
				CN	1047368	A	28/11/1990
				DE	69007855	D,T	28/07/1994
				IE	64119	B	12/07/1995
				IE	901698	A,L	11/11/1990
				JP	1909888	C	09/03/1995
				JP	3001876	A	08/01/1991
				JP	6034824	B	11/05/1994
				NO	902073	A	12/11/1990
				NZ	233636	A	25/11/1992
				PT	94017	A	08/01/1991
US	5816779	A	06/10/1998	AT	245040	T	15/08/2003
				AU	702480	B	25/02/1999
				AU	2586695	A	05/12/1995
				CA	2190098	A,C	25/04/2006
				DE	69531292	D,T	13/05/2004
				DK	751794	T	03/11/2003
				EP	0751794	A,B	16/07/2003
				SE	0751794	T3	
				ES	2202365	T	01/04/2004
				JP	3628699	B	16/03/2005
				JP	10503665	T	07/04/1998
				PT	751794	E	31/12/2003
				US	5586868	A	24/12/1996
				WO	9531233	A	23/11/1995