

A&A Ref: 153338

PUBLICATION PARTICULARS AND ABSTRACT
(Section 32(3)(a) - Regulations 22(1)(g) and 31)

21	01	PATENT APPLICATION NO	22	LOGGING DATE	43	ACCEPTANCE DATE
		2005/08048	5 October 2005		19-09-2006	
51	INTERNATIONAL CLASSIFICATION			NOT FOR PUBLICATION		

B01D B01J

CLASSIFIED BY: **ISA**

71	FULL NAME(S) OF APPLICANT(S)
----	------------------------------

Crystaphase International, Inc.

72	FULL NAME(S) OF INVENTOR(S)
----	-----------------------------

GLOVER, John N.

EARLIEST PRIORITY CLAIMED	COUNTRY	NUMBER	DATE
	33 US	31 10/396,851	32 25 March 2003

NOTE: The country must be indicated by its International Abbreviation - see schedule 4 of the Regulations

54	TITLE OF INVENTION
----	--------------------

Filtration, flow distribution and catalytic method for process streams

57	ABSTRACT (NOT MORE THAN 150 WORDS)
----	------------------------------------

NUMBER OF SHEETS	55
------------------	-----------

The sheet(s) containing the abstract is/are attached.

If no classification is furnished, Form P.9 should accompany this form.
The figure of the drawing to which the abstract refers is attached.

(12) INTERNATIONAL APPLICATION PUBLISHED UNDER THE PATENT COOPERATION TREATY (PCT)

(19) World Intellectual Property
Organization
International Bureau



(43) International Publication Date
4 November 2004 (04.11.2004)

PCT

(10) International Publication Number
WO 2004/094039 A3

- (51) International Patent Classification⁷: B01D 46/42, B01J 39/20 (72) Inventor: and
(75) Inventor/Applicant (for US only): GLOVER, John, N. [US/US]: 16418 Graven Hill, Spring, TX 77379 (US).
- (21) International Application Number: PCT/US2004/006366 (74) Agent: BROWN, Kimberly, L.; Bracewell & Patterson, L.L.P., P.O. Box 61389, Houston, TX 77208-1389 (US).
- (22) International Filing Date: 2 March 2004 (02.03.2004) (81) Designated States (unless otherwise indicated, for every kind of national protection available): AE, AG, AL, AM, AT, AU, AZ, BA, BB, BG, BR, BW, BY, BZ, CA, CH, CN, CO, CR, CU, CZ, DE, DK, DM, DZ, EC, EE, EG, ES, FI, GB, GD, GE, GH, GM, HR, HU, ID, IL, IN, IS, JP, KE, KG, KP, KR, KZ, LC, LK, LR, LS, LT, LU, LV, MA, MD, MG, MK, MN, MW, MX, MZ, NA, NI, NO, NZ, OM, PG, PH, PL, PT, RO, RU, SC, SD, SE, SG, SK, SL, SY, TJ, TM, TN, TR, TT, TZ, UA, UG, US, UZ, VC, VN, YU, ZA, ZM, ZW.
- (25) Filing Language: English
- (26) Publication Language: English
- (30) Priority Data: 10/396,851 25 March 2003 (25.03.2003) US
- (71) Applicant (for all designated States except US): CRYSTAPHAISE INTERNATIONAL, INC. [US/US]; 16825 Northchase Drive, Suite 660, Houston, TX 77060-6029 (US). (84) Designated States (unless otherwise indicated, for every kind of regional protection available): ARIPO (BW, GH, GM, KE, LS, MW, MZ, SD, SL, SZ, TZ, UG, ZM, ZW),

[Continued on next page]

(54) Title: FILTRATION, FLOW DISTRIBUTION AND CATALYTIC METHOD FOR PROCESS STREAMS

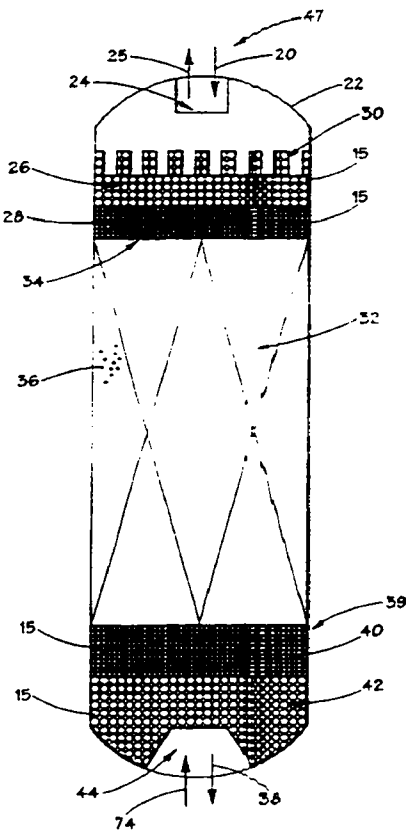

Abstract: A method for removing contaminants from a process stream that includes the use of reticulated material to filter the process stream. The reticulated material also facilitate process stream flow distribution in process units. The reticulated material can be packed with a void space between a substantial number of the reticulated material that can be varied to enhance filtration and flow distribution. The method of filtering also provides a method of removing contaminants leaving process equipment. The methods can be used on a variety of process streams and process equipment. The reticulated material can include ceramics, metallic materials, and chemical vapor deposition elements. The reticulated material can be of various shapes and sizes, and can also be catalytically active

WO 2004/094039 A3

FILTRATION, FLOW DISTRIBUTION AND CATALYTIC METHOD FOR PROCESS STREAMS

BACKGROUND OF THE INVENTION

5 1. Field Of The Invention

[0001] The invention relates to a method of providing filtration of contaminants from process streams. In another aspect, this invention relates to a method for providing flow distribution of process streams in process units. In yet another aspect, this invention provides filtration or flow distribution or both while concurrently catalyzing
10 at least one reaction to at least partially remove and/or convert certain chemical species within the process stream.

2. Description Of Related Art

[0002] Contaminants in process streams can be deleterious to processes and also to process units. Contaminants can damage process units, potentially resulting in an
15 environmental or safety incident. Contaminants can also damage processes by decreasing efficiencies within processes, stopping production, affecting the specifications of products, or the like. Contaminants can be found in all types of process streams, such as feed streams, discharge streams, or effluent streams. Contaminants can affect various types of process units, such as reactors, extractors,
20 distillation columns, scrubbers, tail gas treaters, incinerators, exchangers, boilers, condensers, and the like.

[0003] Process units may be configured such that process streams in the unit flows vertically downward or upward or both. Alternatively, process streams in the unit may flow radially from the center out or from the external part of the unit to the center
25 or both.

[0004] Reactors are one type of process unit. Many reactors include discrete solid catalyst particles contained in one or more fixed beds. Catalyst beds are typically very efficient at trapping contaminants in process streams fed to the catalyst bed. Such catalyst beds, however, can quickly become clogged by these trapped

contaminants. As the bed becomes clogged, pressure drop across the process unit rises resulting in eventual premature shutdown of the process unit.

[0005] Partly to mitigate this problem, catalyst bed process units as well as non-catalyst bed process units are often supplemented with conventional retention material beds that are somewhat less resistant to clogging. These conventional retention material beds are typically located at the inlet to the process unit. In the case of catalyst bed process units, the conventional retention material beds are typically inert to the reactions in the catalyst bed. These conventional retention material beds can be somewhat effective in trapping or filtering all or some contaminants such as dirt, iron oxide, iron sulfide, asphaltenes, coke fines, catalyst fines, sediments or other entrained foreign particulate material in the process stream entering, within or leaving the process unit. The trapping of the contaminants is to prevent undesirable material from clogging or poisoning or otherwise harming the process unit. When these conventional retention material beds are inert they are typically made of conventional ceramic materials in the form of pellets, rings, saddles or spheres and typically must be resistant to crushing, high temperatures and/or high pressures. While these conventional retention material beds can be somewhat effective in preventing the process unit from being clogged, the conventional retention material beds themselves eventually become clogged.

[0006] Conventional retention material beds may also facilitate flow distribution of the process stream in a direction perpendicular to the flow of the process stream across the process unit. Such behavior will be referred to herein as perpendicular flow distribution. As an example, in an upflow or downflow process unit, the process stream flow is in the axial direction and the perpendicular flow distribution is in the radial direction.

[0007] To increase the efficiency of conventional retention material beds, graduated layers of these materials in different sizes and shapes along with perforated discs, or screen baskets, have been used to retard the process unit from becoming clogged with contaminants such as dirt, iron oxide, iron sulfide, asphaltenes, coke fines, catalyst fines, sediments, or other entrained foreign particulate material.

[0008] Conventional retention material beds exposed to contaminants at the inlet to a process unit will eventually become clogged with contaminants. As this happens, the pressure drop across the process unit rises, resulting in the eventual shutdown of the unit. When this happens in catalyst bed process units, it is typical that part of the catalyst bed itself becomes somewhat or completely clogged with contaminants. After such shutdown of the process unit, skimming, or removal, of the clogged portion of the conventional retention material, as well as the clogged portion of the catalyst bed, is required.

[0009] In addition to clogging by contaminants in the process stream, polymerization of polymer precursors, e.g., diolefins, found in the process streams fed to catalyst bed process units may also foul, gum or plug such process units. In particular, two mechanisms of polymerization, free radical polymerization and condensation-type polymerization, may cause catalyst bed fouling, gumming or plugging. The addition of antioxidants to control free radical polymerization has been found useful where the process stream has encountered oxygen. Condensation polymerization of diolefins typically occurs after an organic-based feed is heated. Therefore, filtering prior to the process stream entering the catalyst bed process unit may not be helpful to remove these foulants as the polymerization reactions generally take place in the unit.

[0010] It is highly desirable to have retention materials that do not just clog with contaminants but efficiently and effectively filter contaminants from the process stream. Efficiency relates to the percent of contaminants removed by such materials from the process stream, as well as, to the range of sizes of contaminants that can be removed by such materials. Effectiveness relates to the extent that such materials do not impede the flow of the decontaminated process stream through the retention materials. Such materials would desirably remove virtually all contaminants within a broad range of sizes from the process stream, while not causing an unacceptable pressure drop increase across the process unit. It is also highly desirable to have retention materials that promote perpendicular flow distribution. The method of the present invention for filtration and flow distribution for process streams, when compared with previously proposed prior art methods, has the advantages of providing highly efficient and highly effective filtering of contaminants; increasing

the life and activity of catalysts in catalyst bed process units; decreasing catalyst losses; allowing for the optimization of process unit configuration; improving the perpendicular flow distribution of process streams into and within process units and eliminating the need to take process units off-line when conventional retention
5 material beds have clogged to the point that pressure drop across units have risen to unacceptable levels. These benefits may result in both capital and operating cost savings, reduced downtimes, increased process unit performance and extended process unit operating time.

[0011] Weaknesses of conventional retention material beds are that they are neither
10 particularly efficient nor particularly effective as filters. Conventional retention material beds are typically efficient at removing some contaminants from the process stream for a limited period of time. The contaminants so trapped are typically those about 50 microns and larger. The effectiveness of conventional retention material
15 beds suffers due to eventual clogging, which prevents flow of the decontaminated process stream through the conventional retention material beds and leads to unacceptable increase in process unit pressure drop. Furthermore, conventional retention material beds appear to trap contaminants within about the top six to twelve inches of depth. Deeper beds of conventional retention materials do not increase the
20 trapping capacity of these materials. Therefore, the art has sought filtration methods that remove particulate contaminants smaller than 50 microns, that filter particulate contaminants while allowing the free flow of decontaminated process streams with no significant rise in process unit pressure drop and that have a filtering capacity that increases with bed depth, regardless of bed depth.

[0012] Disadvantages associated with current perpendicular flow distribution designs
25 and methods in process units may result in poor distribution within the process unit. Clogging or other fouling such as that caused by particulate contaminants or the products of undesired polymerization reactions may also cause maldistribution. The maldistribution may result in channeling and corresponding bypassing of portions of the process unit, reduction in the efficiency of contaminant removal and reduction in
30 unit efficiency. Usually, a maldistribution problem is also evidenced by so-called temperature hot-spots. Such hot-spots can, for example, lead to increased coking and

reduced activity in catalyst bed process units. Therefore, the art has sought a perpendicular flow distribution method that may distribute the process stream more uniformly within the process unit, provide efficient filtering of contaminants, reduce the occurrence of hot-spots and reduce fouling caused by undesired polymerization reactions.

[0013] U.S. Patent Nos. 6,258,900 and 6,291,603, both of which are incorporated by reference in their entireties, describe reticulated ceramic materials that are used to filter and distribute organic feed streams in a chemical reactor. A need exists for filtering and flow distribution capabilities for other types of process streams besides organic-based streams and for other types of process units besides chemical reactors.

[0014] It is desirable for the filtering and flow distribution methods for all process streams and all process units to increase the filtering efficiency and effectiveness of materials utilized to remove contaminants from process streams, to improve perpendicular flow distribution within process units, to have unit run length determined by factors other than pressure drop increase, to minimize pressure drops across process equipment, and to minimize process safety and environmental concerns arising from catalyst bed channeling and flow maldistribution, temperature hot-spots and process unit shutdowns and start-ups.

SUMMARY OF INVENTION

[0015] In accordance with the invention, the foregoing advantages have been achieved through the present method of filtering a process stream, for distributing a process stream within a process unit and for accomplishing one or both while concurrently catalyzing desired reactions using reticulated elements. The present invention advantageously provides a method of removing contaminants from a contaminated process stream. The method preferably is performed by passing the process stream over a plurality of reticulated elements in a process unit. The reticulated elements are randomly packed in the process unit such that there is significant void space between each reticulated element to enhance filtration of contaminants on a surface of the reticulated elements while allowing the decontaminated process stream to pass unimpeded through the plurality of reticulated

elements. A surface can include an inner surface and an outer surface. Reticulated elements made in accordance with the present invention will have more inner surface area available for filtering than outer surface area. Reticulated elements can include foam materials and monolith materials. Foam materials generally have a random pattern, while the monoliths have a more uniform pattern. The reticulated elements can be made from any commercially available materials, for example, zirconia toughened alumina, commonly referred to as ZTA. ZTA is available, in a ceramic foam, from Fiber Ceramics, Inc. headquartered in Cudahy, Wisconsin. Another suitable type of ceramic is a monolith, which is manufactured by Corning, Inc. headquartered in Corning, New York. The process stream can be a liquid stream, a vapor phase, or a combination of both phases, and the contaminants can include dirt, iron oxide, iron sulfide, asphaltenes, coke fines, soot, catalyst fines, sediments or other entrained foreign particulate matter, salts in distillation columns, particulates in gas streams, or sulfur or sulfides from tail gas units. The process stream can also be an organic-based process stream. The reticulated elements should be provided in an amount sufficient to remove some or all of the contaminants from the process stream. Another feature of the present invention may include the step of providing a decontaminated process stream for further processing.

[0016] More particularly, the invention relates to a process for improving stream quality of process streams entering to process units. An exemplary example includes improving stream quality of organic-based process streams going to catalytic bed process units. Preferably, the catalytic bed process units use discrete, solid element, fixed catalyst beds. The catalytic bed process units can include hydrotreater, hydrorefiner, hydrocracker, reformer, alkylation, dealkylation, isomerization, oxidation, esterification, and polymerization reactors. The discrete solid catalyst particles may be contained in one or more fixed beds and in either an upflow, downflow or radial flow design.

[0017] In addition to catalytic bed process units, the reticulated elements of the present invention can be used to remove contaminants from other types of process equipment. Such process equipment can include incinerators, scrubbers, tail gas treaters, and distillation columns and any manufacturing units that operate in a

continuous fashion. When used in a distillation column, the reticulated elements can be placed in the bottom of the distillation column to act as a filter to remove salts from the distillation process. Removal of salts will reduce the pressure drop across the tower, allow for better separation efficiency in the column, and increase the time
5 between downtimes typically required to remove these salts from the column.

[0018] The present invention also advantageously provides a method of perpendicular flow distribution in process units. This perpendicular flow distribution method includes providing one or more reticulated elements in the process unit. When only one reticulated element is used, it is typically large enough to effectively span the
10 process unit. When multiple reticulated elements are used, they are typically arranged in a randomly packed bed. Regardless of the configuration of the reticulated elements, each reticulated element has a plurality of web members that define a plurality of flow passageways through the reticulated element. A process stream contacted with the plurality of reticulated elements is therefore subdivided into a
15 plurality of smaller fluid streams by passing the process stream through the plurality of flow passageways defined by the web members of each reticulated element. The flows of the process stream through the flow passageways within the reticulated elements and through the void spaces between the reticulated elements when multiple
20 reticulated elements are used provides for effective flow distribution perpendicular to the flow of the process stream through the process unit. This method can be applied to process streams that are entering the process unit, at any location within the process unit, at the exit from the process unit or any combination of these locations. This method can be applied to process streams while concurrently providing for filtration
25 of contaminants from the process stream. This method can be applied to process streams while concurrently performing catalytic reactions to partially or totally remove or convert desired chemical species in the process stream.

[0019] An additional feature of the present invention can include the step of using reticulated elements in a variety of shapes. The shapes can include substantially spherical shaped balls, monoliths, squares, raschig rings, saddles, hollow cylinders,
30 perforated disks, disks, single sheets, and solid cylinders, among others. Each shape can be sized to individual specifications. Sizes for the shapes used can include

substantially spherical balls of about ¼ to 2-inch diameters; monoliths with widths of about ¼ to 2-inches and lengths of about ¼ to 2-inches; squares with widths of about ¼ to 2-inches and lengths of about ¼ to 2-inches; raschig rings with inside diameters of about ¼ to 1 inch and outside diameters of about ¼ to 1 ½ inches, and heights of about ¼ to 2 inches; saddle shapes with radii of about ¼ to 2 inches; hollow cylinders having inside diameters of about ¼ to 1 ¼ inches, outside diameters of about ¼ to 2 inches, and heights of about ¼ to 3 inches; and solid cylinders having diameters of about ¼ to 1 inch and heights of about ¼ to 2 inches. Custom-made one-piece disks or single sheet construction can be custom-fit to the physical configuration of a reactor. A further feature of this aspect of the present invention is that the reticulated elements can be formed in either a disk or single sheet, each optionally having perforations. An additional feature of the present invention is that the reticulated elements when constructed can be formed into a plurality of segments in order to form an assembled sheet or disk that is custom-fit to the reactor's physical configuration.

15 [0020] An additional feature of the present invention can include the step of using reticulated elements in a variety of porosities and pore sizes. The reticulated elements can be manufactured such that they have a porosity of so many pores per inch ("ppi"). For example, this means that a reticulated element of 30 ppi will, when examined by one skilled in the art, have on average 30 pores per inch. Given that there are about 20 25 millimeters per inch, the pore sizes of such a material would be just under one millimeter. Pore size in this context is the general size of the cavity of the pore recognizing that pores are not perfect spheres. Another important element of pore size is the size of the window opening into the pore. It is this measure that determines the size of the largest particle that be trapped or filtered within the pore. The porosity 25 range of the reticulated elements of the present invention are from 4 to 800 ppi . This enables customization of the size and shape of the reticulated elements for the application constraints including particulate loading and pressure drop constraints. The pores of the reticulated elements can be in a range of about 6 millimeters to about 30 100 microns, each being defined by a plurality of web members forming a plurality of flow passageways through the reticulated elements.

[0021] An additional feature of the present invention can include the step of using reticulated elements with different pore sizes in the same process unit so as to remove contaminant materials of a broad range of sizes. The materials of the present invention can filter contaminants down to about 1 micron in size. Commercially available retention materials are capable of trapping particles down to about 50 micron in size.

[0022] Another feature of the present invention advantageously provides providing a plurality of reticulated elements over an entire length of a process unit. The plurality of reticulated elements can be commingled throughout the process unit with a catalyst, with multiple catalysts or with other materials, such as structured packing materials and the like.

[0023] In accordance with another aspect of the present invention, the step of contacting the contaminated process stream with the reticulated elements may include depositing a catalyst on the reticulated elements prior to contacting the contaminated process stream. Another feature of this aspect of the present invention may include the use of reticulated elements as a substrate having a substantially uniform coating of a selected catalyst including a porous alumina coating with a Group VI-B metal or a Group VIII metal, or both. Preferably, the Group VI-B metal is molybdenum and preferably, the Group VIII metal is either nickel or cobalt. More preferably, the Group VI-B metal and Group VIII metal are impregnated into the reticulated elements. The method of the present invention is useful to extend the run life of the catalyst bed. The catalytically active reticulated elements can be utilized to react diolefins or other polymer precursors and also to act as a filter and as a flow distributor. By filtering solids and partially reacting any polymer precursors, e.g., diolefins, fouling of the catalyst is reduced, effectively extending the run time of the reactor.

[0024] In accordance with another aspect of the present invention, the filtration method may include the step of filtering solid particulate material or sediments that form within a process unit in order to reduce fouling or plugging of downstream equipment. This aspect of the present invention may include the steps of providing

one or more reticulated elements; contacting a process stream containing the particulate material or sediments with the reticulated elements; removing the particulate material or sediments from the process stream; and providing a relatively particulate material or sediments-free process stream for further processing. The reticulated elements can be located at one or more locations within the process unit or at the outlet of the process unit or a combination of both. This method of removing sediments can also be used in distillation columns to provide a relatively sediment free process stream for further processing. The method of the present invention for filtering process streams in catalytic bed process units, when compared with prior art methods, has the advantages of reducing the volume of retention materials required; lowering capital costs; improving the filtration of the solid particular matter from the feed streams; decreasing the pressure drop across the system; increasing run time of the reactor; allowing for the use of catalysts that have higher activity, lowering operating costs; increasing process safety; and reducing environmental concerns.

15

BRIEF DESCRIPTION OF DRAWING

[0025] In the drawing:

[0026] FIG. 1 is partial a cross-sectional side view of a single fixed catalytic bed process unit showing a specific embodiment of the present invention;

[0027] FIG. 2 is a partial cross-sectional side view of a multiple fixed bed chemical reactor showing another embodiment of the present invention;

[0028] FIG. 3 is a partial cross-sectional side view of a combustor-style regenerator fluidized bed reactor showing an embodiment of the present invention;

[0029] FIG. 4 is a partial cross-sectional side view of a two-stage regenerator fluidized bed reactor showing an embodiment of the present invention;

[0030] FIG. 5 is a partial cross-sectional side view of a radial flow reactor showing another embodiment of the present invention;

[0031] FIG. 6 is a perspective view of a perforated disk made of reticulated material in accordance with the present invention;

[0032] FIG. 7 is a perspective view of a saddle made of reticulated material in accordance with the present invention;

5 [0033] FIG. 8 is a perspective view of a hollow cylinder made of reticulated material in accordance with the present invention;

[0034] FIG. 9 is a perspective view of an example of a one-piece sheet made of reticulated material in accordance with the present invention;

10 [0035] FIG. 10 is a perspective view of an assembled disk made of reticulated material in accordance with the present invention;

[0036] FIG. 11 is a perspective view of balls made of reticulated material in accordance with the present invention;

[0037] FIG. 12 is a perspective view of a solid cylinder made of reticulated material in accordance with the present invention;

15 [0038] FIG. 13 is a perspective view of a hollow cylinder made of reticulated material in accordance with the present invention;

[0039] FIG. 14 is a perspective view of a monolith made of reticulated material in accordance with the present invention;

20 [0040] FIG. 15 is a partial cross-sectional side view of a distillation column showing an embodiment of the present invention;

[0041] FIG. 16 is a perspective view of a layer of reticulated elements with a void space between each reticulated element that is varied in accordance with the present invention;

[0042] FIG. 17 is a graph comparing the pressure drop in distillate hydrotreaters with the reticulated elements of the present invention installed to the pressure drop in a distillate hydrotreaters with prior art, retention materials installed;

5 [0043] FIG. 18 is a graph illustrative of the effect of the present invention on the pressure drop in naphtha hydrotreater units;

[0044] FIG 19 is a partial cross-sectional side view of a down-flow process unit with multiple layers of reticulated elements to provide the methods of the present invention at the entrance of the process unit, at two other locations within the process unit and at the outlet of the process unit in accordance with an embodiment of the present
10 invention;

[0045] FIG. 20 is a partial cross-sectional view of a process unit with layers of reticulated elements of differing porosities to enable filtering of contaminants with a wide range of particle sizes in accordance with an embodiment of the present invention;

15 [0046] FIG. 21 is a perspective view of a top and a bottom of a piece of a reticulated element on which had been dripped water tinted with food coloring illustrating the perpendicular flow distribution of the reticulated elements in accordance with the present invention; and

[0047] FIG. 22 is a perspective view of a process unit with the reticulated elements of
20 the present invention randomly packed throughout an entire length of a catalyst bed according to an embodiment of the present invention.

[0048] While the invention will be described in connection with the preferred
embodiment, it will be understood that it is not intended to limit the invention to that
embodiment. On the contrary, it is intended to cover all alternatives, modifications,
25 and equivalents, as may be included within the spirit and the scope of the invention as defined by the appended claims.

DETAILED DESCRIPTION AND SPECIFIC EMBODIMENTS

[0049] With reference to FIG. 1, for treatment of a process stream a single fixed catalytic bed process unit 22 with reticulated elements 15 in the shape of substantially spherical balls 122 (FIG. 11) will be described, although as previously discussed other shapes of the reticulated elements 15 may be used, as well as other process units . If the process unit 22 is of a downflow configuration, the contaminated process stream 20 will enter the process unit 22 at the inlet 24. The invention may be used in either fixed or fluidized catalytic bed process units. Preferably, the present invention is used in one or more fixed beds, in either an upflow or downflow or radial flow configuration. Preferably, the catalytic bed process units include hydrotreater, hydrorefiner, hydrocracker, reformer, alkylation, dealkylation, isomerization, esterification, and polymerization reactors. Contaminants typically found in the feed stream include dirt, iron oxide, iron sulfide, asphaltenes, coke fines, soot, catalyst fines, sediments or other entrained foreign particulate matter, salts in distillation columns, particulates in gas streams, sulfur or sulfides from tail gas units, or polymer precursors such as diolefins. A layer 26, preferably layers 26, 28, of reticulated elements 15 is provided in the vessel in an amount sufficient to filter the contaminants from the process stream 20 for as long as desired including, but not limited to, as long as the catalyst within the reactor is sufficiently active to justify operation of the reactor. Preferably, multiple layers 26, 28 can be provided wherein the size of the reticulated elements 15 such as balls 122 is graduated from one size in layer 26 to another size in layer 28 as the incoming process stream flows through the bed of reticulated elements 15. Reticulated elements can include foam materials and monolith materials. Foam materials generally have a random pattern, while the monoliths have a more uniform pattern. If a reticulated ceramic element is used, the reticulated ceramic elements can be made from any commercially available materials, for example, zirconia toughened alumina, commonly referred to as ZTA. ZTA is available from Fiber Ceramics, Inc. headquartered in Cudahy, Wisconsin. An exemplary monolith for use in the present invention is available from Corning, Inc. headquartered in Corning, New York. The graduated sizing of the reticulated elements 15 allows the filtering of a broad range of sizes of contaminants.

[0050] The present invention advantageously provides a method of removing contaminants from a contaminated process stream. The method preferably is performed by providing reticulated elements preferably randomly packed with a void space between each reticulated element to enhance filtration of contaminants in such a way that the decontaminated process stream may pass through the reticulated material unimpeded. The present invention provides a method whereby the entirety of the reticulated elements can be utilized to filter contaminants from the process stream. In catalytic bed process units, the reticulated elements can be sized such that the catalyst bed has exhausted its catalytic activity before the reticulated elements have exhausted their ability to filter out contaminant particles. This method enables use of the entire bed of reticulated elements, as opposed to current methods that eventually clog the top six to twelve inches of the retention materials conventionally available. With such materials, beds deeper than about one foot are essentially of no use in removing particulate contaminants from process streams. Further, with such materials, once the top of the bed is plugged, the pressure drop in the equipment begins to escalate, requiring a shutdown to remove and replace the clogged materials from the process unit.

[0051] Data has been collected from different process units that have experimented with the reticulated elements of the present invention. The reticulated elements of the current invention have performed dramatically better than conventional retention materials available commercially.

Example 1 – Use in a Distillate Hydrotreater

[0052] Data was obtained from a refinery for four distillate hydrotreaters in virtually identical process conditions. Two of the hydrotreaters, A and B, contained conventional reticulated materials, known as “ring grading systems.” The remaining two hydrotreaters, C and D, used the reticulated elements of the present invention. FIG. 17 shows a comparison of the pressure drop of the four hydrotreaters using conventional ring grading systems and the reticulated elements of the present invention. As can be seen in the graph, the pressure drop remained low relative to start-of-run pressure drop over a period in excess of 450 days in the C and D

hydrotreaters containing the reticulated elements, while the A and B hydrotreaters using the conventional ring grading system showed a dramatic pressure increase after only 200 days in service. The results of the pressure drop comparison can be seen in Table 1. The contaminated process streams in the distillate hydrotreaters were predominantly in a liquid phase. In the C hydrotreater, the differential pressure was only 8 psi at 450 days. In the D hydrotreater, the differential pressure was only 0.5 psi at 450 days. The differential pressure for the A and B hydrotreaters was 82.5 psi and 54 psi respectively. In comparison, the C and D hydrotreaters with the reticulated elements of the present invention performed significantly better than the conventional ring grading systems. The lower differential pressure associated with the reticulated elements of the present invention allows the time between turnarounds to be extended dramatically.

Hydrotreater	Initial ΔP at 0 day	ΔP at 200 days	ΔP at 450 days	% Change from 0 days to 450 days
A	17.5	38	100	470% increase
B	21	38	75	257% increase
C	30	30	38	27% increase
D	39	40.5	39.5	1.3% increase

[0053] A typical pressure drop scenario is to have a low pressure drop for the first months of operation, but then, at a time that is not predictable, the pressure increases significantly over a relatively short period to a point where the unit must be shutdown to remove the pluggage, replace the removed material and restart the unit. This can be problematic given the unpredictability of the event, the need to acquire replacement materials with very short lead-time or to maintain sufficient extra inventory of replacement materials or to extend the down-time to await delivery of replacement materials. With use of the reticulated elements in accordance with the methods described herein, the pressure drop remains low for a predictable period of

time based on the level of contaminants in the process stream and the capacity of the reticulated elements loaded in the process unit. Sufficient reticulated elements may be loaded such that the catalyst in the unit is exhausted before the reticulated elements are saturated.

5 Example 2 – Use in a Naphtha Hydrotreater

[0054] Data was obtained from a refinery with four naphtha hydrotreaters. Three of the hydrotreaters (A, B, and C) used conventional ring grading systems, while the remaining hydrotreater (D) used the reticulated elements of the present invention. FIG. 18 illustrates that comparative pressure drop between the four hydrotreaters. At
10 the end of 200 days, the unit with the reticulated elements D experienced minimal pressure drop, i.e. -4 psi for hydrotreater D, compared to the pressure drop experienced by the three units containing ring grading systems, i.e. 10 psi for hydrotreater B and 22 psi for hydrotreater C. The contaminated process streams in the naphtha hydrotreaters were predominantly in a vapor phase. The reticulated
15 elements of the present invention filtered efficiently and effectively while the conventional ring grading systems became clogged.

[0055] Referring again to FIG. 1, unless otherwise noted, in addition to filtering the contaminated process stream 20, the reticulated material 15 may also enable a uniform distribution and flow of the incoming process stream 20 to the catalyst bed
20 32.

[0056] By passing the process stream through a plurality of flow passageways 120 (FIG. 9) defined by web members 123 (FIG. 9) of the reticulated material 15 in layers 26, 28, the incoming process stream 20 may also be distributed by subdividing the incoming process stream into a plurality of smaller fluid streams and then
25 resubdividing, a plurality of times, the smaller streams so that the incoming process stream is spread uniformly across the fluid entry cross-section 34, taken along line 34 – 34, of the catalyst bed 32. The process stream 20 is reacted in the catalyst bed 32. Preferably the catalyst bed 32 contains discrete solid catalyst particles 36.

[0057] For catalytic bed process units, methods of the present invention filter particulate contaminants before they reach the catalytic bed. This allows for increased efficiency of the catalyst bed since more of the surface area of the catalyst is available for use as a catalyst when compared to systems with conventional retention materials, such as the ring grading systems used in Examples 1 and 2. As a result, smaller sized, more catalytically active catalyst elements can be used due to the lower average pressure drop of the unit resulting in a gain in catalyst activity of about 10%–15%.

[0058] The reticulated material 15 may be used to filter and retain particulates 36 from the outgoing process stream 38. Small particulate material 36 that may be entrained in the outlet process stream may be filtered, or captured, from the process stream 38 and retained by reticulated material layers 40, 42. Preferably, the size of the reticulated material in layers 40, 42 is graduated from a size in layer 40 to another size in layer 42 at the outlet 44 of the reactor 22. In addition, sediments of material may form in the process unit, e.g., sediments formed by excessive hydrocracking of residual oils, that may plug or foul downstream equipment. These sediments may be filtered from the outgoing process stream 38 by the reticulated material 15. Preferably, the size of the reticulated material in layers 40, 42 is graduated from a size in layer 40 to another size in layer 42 at the outlet 44 of the reactor 22. Alternately, the invention may also be used in an upflow configuration wherein the contaminated process stream 46 would instead enter the unit at 44 at the lower end 39 and the outlet process stream 25 would exit the process unit at 24 at the upper end 47 of reactor 22.

[0059] As previously discussed, another advantage of the present invention is to react activated or partially activated reticulated material 15 with polymer precursors in a contaminated process stream 20. Condensation polymerization of diolefins may occur in the process unit 32 after the contaminated process stream 20 is heated, generally prior to introduction into the process unit 22, thereby forming foulants in the process unit 32 itself that may gum or plug the process unit 32. As the foulants form in the process unit, they cannot be filtered from the contaminated process stream 20 before flowing across the fluid entry cross-section 34. Therefore, the layer or layers 26, 28, 40, 42 of reticulated material 15 may be coated with an alumina powder that

may also act as a substrate for catalyst materials to form partially activated reticulated material. As used herein, an "activated support" means (1) a reticulated material that has been impregnated with catalyst materials or (2) a reticulated material that may be an oxide, nitride, or carbide of a metal or (3) a reticulated material that contains
5 zeolite or inorganic oxides, e.g., alumina, silica, silica-alumina, magnesia, silica-magnesia or titania. As used herein, a "partially activated support" means an activated support material that has been purposefully made less active or partially deactivated in order to achieve a slower reaction rate or to partially react the materials contacted.

[0060] Coated reticulated material 15 may also be used, wherein the coating may
10 comprise one of several conventional catalysts. Alumina may be used as an active coating, optionally but preferably, alumina may be used as a support to strengthen the catalyst. The catalyst according to this invention preferably comprises a metal of Group VI-B or a member of Group VIII, or both, impregnated into an alumina based support. Accordingly, the catalyst may comprise at least one of chromium,
15 molybdenum and tungsten in combination with at least one of iron, nickel, cobalt, platinum, palladium and iridium. The use of palladium is particularly useful in the removal of acetylene and diolefins from ethylene, the removal of oxygen, and the removal of hydrogen. Of the Group VI-B metals, molybdenum is most preferred. The catalyst preferably will contain from about 2% to about 14% by weight of Group
20 VI-B metal. Of the Group VIII metals, nickel and cobalt are most preferred. The amount of Group VIII metal in the catalyst is preferably from about 0.5% to about 10% by weight.

[0061] With reference to FIG. 2, a multiple fixed catalyst bed process unit 46 having
25 two fixed catalyst beds 48, 50 with reticulated material 15 in the shape of saddles 126 (FIG. 7) will be described. The reactor 46 is illustrated in a downflow configuration, wherein the contaminated process stream 51 will enter the unit 46 at the inlet 52 and the outlet process stream 54 will exit the unit at the outlets 56, 60. A partially reacted process stream 58 may be accumulated at the outlet 61 of the first fixed bed 48 and withdrawn at the collector tray 60. The partially reacted process stream 58 may be
30 heated or quenched or otherwise treated before reintroduction into the reactor 46 as a partially reacted process stream 62 at the mixing chamber 64. The partially reacted

process stream 58 may be removed for redistribution, heating, or other processing steps as required before reintroducing the partially reacted process stream 62 into the reactor 46 for reaction with a succeeding catalyst bed 50. An additional layer 70 of reticulated material 15 may be provided for filtration and distribution to remove any
5 contaminants entrained from or formed by the processing equipment used in the additional processing steps such as dirt, iron oxide, iron sulfide, asphaltenes, coke fines, soot, catalyst fines, sediments or other entrained foreign particulate matter, salts in distillation columns, particulates in gas streams, sulfur or sulfides from tail gas units, or polymer precursors such as diolefins.

10 [0062] Layers 66, 68, 70 of reticulated material 15 are provided in the reactor 46 below the inlet 52 and mixing chamber 64 in an amount sufficient to filter the process stream 51 and the partially reacted process stream 62. Preferably, the multiple layers 66, 68, 70 are provided such that the porosity of the reticulated material 15 is graduated from a porosity in layer 66 to another porosity in layer 68 to another
15 porosity in layer 70 as the incoming contaminated process stream flows through the reticulated material 15. Optionally, the present invention may be practiced with or without conventional basket screens 72. Preferably, the fixed catalyst beds 48, 50 contain discrete solid catalyst particles 74.

[0063] Another feature of the present invention advantageously provides providing a
20 plurality of reticulated elements 15 over an entire length of a process unit. The plurality of reticulated elements 15 can be commingled throughout the process unit with a catalyst 19, as shown in FIG. 22.

[0064] As previously discussed, an advantage of the present invention is that it may also be used to distribute the process stream. The process stream 51 may also be
25 distributed while being filtered by subdividing the incoming process stream into a plurality of smaller fluid streams by passing the process stream through a plurality of flow passageways 120 (FIG. 9) defined by the web members 123 (FIG. 9) of the reticulated material 15; then resubdividing, a plurality of times, the smaller streams so that the incoming process stream is spread uniformly across the fluid entry cross-
30 section of the catalyst bed 76. The feed 51 is then reacted in the catalyst bed 48,

before being withdrawn as a partially reacted process stream 58 at the collector plate 60. The method of filtration and distribution is then repeated for the partially reacted process stream 62 as it flows into the mixing chamber 64 and passes through the reticulated material layer 70.

- 5 [0065] Another feature of the present invention is that the reticulated material 15 may also be used to capture and retain catalyst particles 74 from the outflowing partially reacted process stream 58 and the reacted process stream 54. The reticulated material 126 in layers 78, 80 at the outlet 61 of the first fixed bed 48 and the reticulated material 126 in layers 82, 84 at the outlet 56 of the second fixed bed 50 are used to
10 filter and retain catalyst particles 74 that may be entrained in the partially reacted process stream 58 or reacted process stream 54. As discussed with reference to FIG. 1, for capturing and retaining catalyst 74 from a partially reacted or a reacted outflowing process stream in either a single or a multiple fixed bed chemical reactor, the reticulated material 15 is preferably graduated from a porosity to another porosity
15 as shown in FIG. 2 for layers 78, 80 and 82, 84, respectively for each bed 48, 50. Optionally, the porosity of the reticulated material may also be graduated from small pores to large pores. Alternatively, the porosity of the reticulated material may be inversely graduated from large pores to small pores to filter sediments that may form in the catalyst bed.
- 20 [0066] A further advantage of the present invention is that the reticulated material 15 may be activated or impregnated with catalytically active material to react with polymer precursors in process streams 51, 62. As depicted in FIG. 2, layers 66, 68, 70 of reticulated material 15 may contain an activated support including inorganic oxides preferably selected from the group consisting of alumina, silica, silica-alumina,
25 magnesia, silica-magnesia or titania or zeolites preferably selected from the group consisting of zeolite L, zeolite X, and zeolite Y, which may be added to the reticulated material as a substrate for catalyst materials. Optionally, the reticulated material may be impregnated with catalyst materials or the reticulated material may be an oxide, nitride, carbide or boride of a metal as disclosed in U.S. Patent No. 5,399,535, which
30 is hereby incorporated by reference to the extent it is not inconsistent with the present invention.

[0067] Activated or partially activated reticulated material as described above may be used to control the hydrogenation rate of the diolefins or other polymer precursors to prevent fouling or gum formation. When endothermic reactions require the addition of heat to the partially reacted process stream 58, preferably the reticulated material 5 of layer 70 is also activated or partially activated. The invention may also be practiced with coated reticulated material, wherein the coating may comprise one of several conventional catalysts. Alumina may be used on an active coating or support. The catalyst according to this invention preferably comprises a metal of Group VI-B or a member of Group VIII, or both, impregnated into the reticulated material, 10 inorganic oxide or zeolite. Accordingly, the catalyst may comprise at least one of chromium, molybdenum and tungsten in combination with at least one of iron, nickel, cobalt, platinum, palladium and iridium. Of the Group VI-B metals, molybdenum is most preferred. The catalyst preferably will contain from about 2% to about 14% by weight of Group VI-B metal. Of the Group VIII metals, nickel and cobalt are most 15 preferred. The amount of Group VIII metal in the catalyst is preferably from about 0.5% to about 10% by weight.

[0068] FIG. 3 illustrates a conventional combustor-style fluidized bed reactor 88, 90. Layers 86, 92 of reticulated material 15 may be used in fluidized bed chemical reactors 90 and in a combustor, or regenerator 88, to reduce entrance losses and 20 maldistribution of the vapor or air flows. The inlet air 94 to the combustor or regenerator 88 is flowed through the reticulated material layer 86 to subdivide the stream into a plurality of smaller flowing streams. The reticulated material 15 may be a single circular disk 124 (FIG. 6) without the illustrated perforation 125; however it may be an oval or square sheet 121 (FIG. 9), or any geometric configuration desired 25 including an assembled disk 134 (FIG. 10). Optionally, multiple disks 86, 92 (FIG. 3) may be used. Also, the disk 124 (FIG. 7) or sheet 121 (FIG. 9) may optionally contain perforations. The subdivision of the vapor or air flows may reduce the turbulence of the incoming vapor or air streams, thus reducing the compressor horsepower usage or allowing for an increase in flow rate, depending on the process 30 constraints of the particular combustor-style fluidized bed reactor (FIG. 3). A further advantage of the present invention is that the subdivided vapor or air flows may more

uniformly distribute the vapor or air 94 throughout the combustor or regenerator 88. In addition, another layer 92 of reticulated material 15 may be used to uniformly distribute any fluffing vapors 96 used in the fluidized bed reactor 90.

[0069] Alternatively, in FIG. 4, which depicts a conventional two-stage regenerator fluidized bed reactor 104, layers 98, 112 of the reticulated material 15 may be used
5 similarly as discussed in FIG. 3 for a single-stage combustor or regenerator. The turbulent inlet air 102 to the combustor or regenerator first stage 108 is flowed through the layer 98 of reticulated material 15 to subdivide the stream, preferably into a plurality of smaller flowing streams. Preferably, the reticulated material 15 is a
10 single circular disk 124 (FIG. 6) without the perforations 125; however it may be an oval or square sheet 121 (FIG. 9), or any geometric configuration desired including an assembled disk 134 (FIG. 10). Optionally, multiple disks 98,112 (FIG. 4) may be used. Also, the disk 124 (FIG. 7) or sheet 121 (FIG. 9) may optionally contain perforations. Similarly, for the second-stage 110, the turbulent inlet air 106 may be
15 flowed through the layer 100 of reticulated material 15 to subdivide the stream into a plurality of smaller flowing streams. The subdivision of the vapor or air flows may reduce the turbulence of the incoming vapor or air streams, thus reducing the compressor horsepower usage or allowing for an increase in flow rate, depending on the process constraints of the two-stage regenerator fluidized bed reactor 104, 116. A
20 further advantage of the present invention is that the subdivided vapor or air flows may more uniformly distribute the vapor or air throughout the combustor or regenerator chambers 108, 110. In addition, another layer of reticulated elements 112 may be used to uniformly distribute any fluffing vapors 114 used in the fluidized bed reactor 116.

[0070] With reference to FIG. 5, for treatment of a contaminated process stream in vapor form, a radial flow fixed bed chemical reactor 94 with reticulated material 15 in the shape of substantially spherical balls 122 (FIG. 11) is illustrated, although, as previously discussed, other shapes may be used. The contaminated process stream in vapor form 92 will enter the radial flow reactor 94 at the inlet 96. A layer 98 of
30 reticulated material 15, more preferably layers 98, 100 of reticulated material 15, is provided in the vessel between the deflection baffle 102 and the scallop 104. The

layers of 98, 100 reticulated material 15 aid in filtering contaminants such as dirt, iron oxide, iron sulfide, asphaltenes, coke fines, soot, catalyst fines, sediments or other entrained foreign particulate matter, or polymer precursors such as diolefins entrained in the contaminated vapor feed 92 before reaction in the fixed catalyst bed 108 and discharge through the center pipe 110 as the reacted process stream 112. Also as previously discussed, an advantage of the present invention is that the reticulated material 15 may be used to capture and retain catalyst from outlet streams, shown here in the unloading tubes 106.

[0071] The reticulated elements can be used to filter contaminants, such as sediments, in other types of process equipment. FIG. 15 illustrates another embodiment of the present invention. In this embodiment, reticulated elements 95 are used for removing sediments, such as salts, in a distillation column 90. The method of filtering sediments formed in process equipment preferably includes providing a layer of reticulated elements packed with a void space between each reticulated element. The void space is varied to enhance filtration of smaller contaminants on a surface of the reticulated elements while allowing larger contaminants to pass through to prevent pluggage of the layer of reticulated elements. The method further provides for contacting a process stream containing the sediments with the reticulated elements thereby removing the sediments from the process stream by removing the smaller contaminants on the surface of the reticulated elements and allowing the larger contaminants to proceed through the void spaces between each reticulated element. This method produces a relatively sediment-free process stream for further processing.

[0072] FIG. 6 illustrates a specific embodiment of the present invention as a reticulated elements disk 124. Optionally, the disks may have perforations 125. Preferably, multiple perforations are used to accommodate screen baskets that may optionally be filled with reticulated elements. Other shapes may include saddles 126 (FIG. 7), hollow cylinders 128 (FIG. 8), single sheets 121 of reticulated material 15 (FIG. 9), disks 134 formed from a plurality of segments 134 a-f (FIG. 10), substantially spherical balls 122 (FIG. 11), solid cylinders 132 (FIG. 12), raschig rings 130 (FIG. 13), squares (FIG. 14), and monoliths (FIG. 14). Each shape may be sized

to individual specifications. Sizes for the shapes used may include substantially spherical balls of about $\frac{1}{8}$ to 2 inch diameters; raschig rings with inside diameters of about $\frac{1}{8}$ to 1 inch and outside diameters of about $\frac{1}{4}$ to 1 $\frac{1}{2}$ inches and heights of about $\frac{1}{4}$ to 2 inches; saddle shapes with radii of about $\frac{1}{4}$ to 2 inches; hollow cylinders
5 having inside diameters of about $\frac{1}{8}$ to $1\frac{1}{4}$ inches, outside diameters of about $\frac{1}{4}$ to 2 inches, and heights of about $\frac{1}{4}$ to 3 inches; and solid cylinders having diameters of about $\frac{1}{8}$ to 1 inch and heights of about $\frac{1}{4}$ to 2 inches. Custom-made one-piece disks 124 or single sheet 121 construction may be custom-fit to the physical configuration of a reactor. A further feature of this aspect of the present invention is that the
10 reticulated material 15 may be formed in either a disk 124 or single sheet 121 having perforations 125. An additional feature of the present invention is that the reticulated elements when constructed may be formed into a plurality of segments in order to form an assembled sheet or disk that is custom-fit to the reactor's physical configuration. Porosities of the reticulated elements may range from 4 to 800 ppi.
15 Preferably, the porosity may range from about 4 to 80 ppi. More preferably, the porosity may range from about 10 to 60 ppi. This enables customization of the size and shape of the reticulated material 15 for the application, size, particulate loading and pressure drop constraints. The reticulate element material surrounding the pores, or openings, of the reticulated elements form the web members 123 (FIG. 9), which in
20 turn define the flow passageways 120 (FIG. 9).

[0073] The present invention also advantageously provides a method of perpendicular flow distribution in process units. This perpendicular flow distribution method includes providing one or more reticulated elements in the process unit. When only
25 one reticulated element is used, it is typically large enough to effectively span the process unit. When multiple reticulated elements are used, they are typically arranged in a randomly packed bed. Regardless of the configuration of the reticulated elements, each reticulated element has a plurality of web members that define a plurality of flow passageways through the reticulated element. A process stream contacted with the plurality of reticulated elements is therefore subdivided into a
30 plurality of smaller fluid streams by passing the process stream through the plurality of flow passageways defined by the web members of each reticulated element. The

flows of the process stream through the flow passageways within the reticulated elements and through the void spaces between the reticulated elements when multiple reticulated elements are used provides for effective flow distribution perpendicular to the flow of the process stream through the process unit. This method can be applied
5 to process streams that are entering the process unit, at any location within the process unit, at the exit from the process unit or any combination of these locations, as illustrated in FIG. 19. This method can be applied to process streams while concurrently providing for filtration of contaminants from the process stream. This method can be applied to process streams while concurrently performing catalytic
10 reactions to partially or totally remove or convert desired chemical species in the process stream.

[0074] FIG. 21 illustrates the amount of perpendicular flow that the reticulated elements of the present invention are capable of producing. An experiment was performed using a dropper with a dropper diameter of approximately 1/16". The
15 reticulated element distributed the liquid perpendicularly to a diameter of about seven times the diameter of the dropper. The flow was not distributed down the reticulated element as much. The significant distribution was made in the horizontal plane and not a vertical plane. When used in process units, the reticulated elements significantly perpendicularly disperses the fluid to prevent channeling and other problems
20 discussed herein.

[0075] An additional feature of the present invention can include the step of using reticulated elements in a variety of porosities and pore sizes, as shown in FIG. 20. The reticulated elements can be manufactured such that they have a porosity of so many pores per inch ("ppi"). For example, this means that a reticulated element of 30
25 ppi will, when examined by one skilled in the art, have on average 30 pores per inch. The pore sizes of such a material would be just under one millimeter. Pore size in this context is the general size of the cavity of the pore recognizing that pores are not perfect spheres. Another important element of pore size is the size of the window opening into the pore. It is this measure that determines the size of the largest particle
30 that be trapped or filtered within the pore. The porosity range of the reticulated elements of the present invention are from 4 to 800 ppi . This enables customization

of the size and shape of the reticulated elements for the application constraints including particulate loading and pressure drop constraints. The pores of the reticulated elements can be in a range of about 6 millimeters to about 100 microns, each being defined by a plurality of web members forming a plurality of flow
5 passageways through the reticulated elements.

[0076] As an advantage of the present invention, the filtering method provides for more efficient filtration within the process unit. Since the contaminants do not cake up on the first inches of the reticulated elements, as with conventional retention materials, all of the filter bed can be effectively used. Pressure drop through the
10 reticulated elements can remain low as long as sufficient reticulated elements are utilized such that the process unit reaches an end-of-run condition other than pressure drop increase. The lower pressure drop increases the safety of operating the unit since downstream equipment is not deprived of flow and the upstream equipment does not pressure up. The run times between catalyst changes are significantly increased since
15 the process equipment can operate much longer than with previous filtration methods before the process equipment end-of-run conditions.

[0077] Another advantage of the present invention is that smaller sized catalysts can be used in catalyst bed process units since the catalyst bed is subjected to a much lower cycle-average pressure drop. The result of using the smaller, more catalytically
20 reactive catalyst is a gain in activity of about 10% to about 15%. The entire surface area of the catalyst can be used for its intended purpose, which is to modify and increase the rate of a reaction, due to a much lower average pressure drop per cycle for the process unit.

[0078] Another advantage of the present invention is, as depicted in FIG 21, the use
25 of one or more layers of reticulated elements at various locations within a process unit to facilitate perpendicular flow redistribution to mitigate channeling and other symptoms of flow maldistribution. Such one or more layers of reticulated elements within a process unit also facilitate filtration of particulate contaminants within the process unit.

[0079] It is to be understood that the invention is not to be limited to the exact details of construction, operation, exact materials, or embodiments shown and described, as obvious modifications and equivalents will be apparent to one skilled in the art. For example, special liquid distributors or conventional liquid distributors could be used
5 the reticulated elements to facilitate the spreading of the liquid across process equipment. Conversely, the reticulated elements could be used only for particulate removal. Accordingly, the invention is therefore to be limited only by the scope of the appended claims.

CLAIMS**WHAT IS CLAIMED:**

1. A method of removing contaminants from a contaminated process stream comprising the steps of:
 - 5 (a) providing a plurality of reticulated elements in a process unit;
 - (b) randomly packing the plurality of reticulated elements within the process unit thereby providing a void space between a substantial number of the reticulated elements to enhance filtration of contaminants on a surface of the plurality of reticulated elements to produce a substantially
10 decontaminated process stream; and
 - (c) contacting the contaminated process stream with the plurality of reticulated elements to remove contaminants from the contaminated process stream while allowing the substantially decontaminated process stream to pass unimpeded through the plurality of reticulated elements.
- 15 2. The method of claim 1, wherein the plurality of reticulated elements have different pore sizes so that the plurality of reticulated elements can filter contaminants of different sizes.
3. The method of claim 1, wherein the contaminated process stream is a contaminated organic-based process stream.
- 20 4. The method of claim 3, further including depositing a catalyst on the plurality of reticulated elements prior to contacting the contaminated process stream.
5. The method of claim 1, wherein the reticulated elements comprise a material selected from the group consisting of a ceramic material, a metallic material, and a chemical vapor deposition material.
- 25 6. The method of claim 1, wherein a substantial number of the plurality of reticulated elements have a plurality of pores defined by a plurality of web members forming a plurality of flow passageways through the plurality of reticulated elements and an average pore size of the pores is about 6 millimeters to about 100 microns.
7. The method of claim 1, wherein the plurality of reticulated elements have a
30 porosity of about 4 to 800 pores per linear inch.
8. The method of claim 1, wherein the reticulated elements are formed from a reticulated foam material.

9. The method of claim 1, wherein the reticulated elements have a shape selected from the group consisting of substantially spherical shaped balls, raschig rings, saddle shaped pieces, monoliths, squares, a single sheet, hollow cylinders, solid cylinders, and a single disk.
- 5 10. The method of claim 9, wherein the reticulated elements are formed having perforations.
11. The method of claim 1, wherein the process unit has an inner cross-sectional configuration and the plurality of the reticulated elements are formed into an assembled sheet that, when constructed, is custom-fit to the process unit's inner cross-
- 10 sectional configuration.
12. The method of claim 1, wherein the process unit has an inner cross-sectional configuration and the plurality of the reticulated elements are formed into a plurality of segments forming an assembled disk that, when constructed, is custom-fit to the process unit's inner cross-sectional configuration.
- 15 13. The method of claim 1, wherein the process unit is selected from the group consisting of a distillation column, a tail gas treater, an incinerator, and a scrubber.
14. The method of claim 1, wherein the reticulated elements comprise a substrate of reticulated elements having a substantially uniform coating of a selected catalyst including a porous alumina coating with one Group VI-B metal.
- 20 15. The method of claim 14, wherein the Group VI-B metal is molybdenum.
16. The method of claim 1, wherein the reticulated elements comprise a substrate of reticulated elements having a substantially uniform coating of a selected catalyst including a porous alumina coating with one Group VIII metal.
17. The method of claim 16, wherein a Group VIII metal is nickel or cobalt.
- 25 18. The method of claim 1, wherein a Group VI-B metal is impregnated into the reticulated element.
19. The method of claim 1, wherein a Group VIII metal is impregnated into the reticulated element.
20. The method of claim 1, wherein the reticulated elements comprise a porous
- 30 inorganic oxide selected from the group consisting of alumina, silica, silica-alumina, magnesia, silica-magnesia and titania.

21. The method of claim 1, wherein the reticulated elements comprise a metal oxide selected from the group consisting of titanium, tin, lead, zirconium, ruthenium, tungsten, yttrium, nickel, magnesium, calcium, aluminum, silicon or boron.
22. The method of claim 1, wherein the reticulated elements comprise a metal
5 nitride selected from the group consisting of titanium, zirconium, tungsten, silicon or boron.
23. The method of claim 1, wherein the reticulated elements comprise a metal carbide selected from the group consisting of titanium, zirconium, tungsten, silicon or boron.
- 10 24. The method of claim 1, wherein the reticulated elements comprise a metal boride selected from the group consisting of titanium, zirconium or tungsten.
25. The method of claim 1, wherein the reticulated elements comprise a zeolite selected from the group consisting of zeolite L, zeolite X and zeolite Y.
26. A method of perpendicular flow distribution in a process unit comprising the
15 steps of:
- (a) providing a plurality of reticulated elements in a process unit having a plurality of web members that define flow passageways that facilitate perpendicular flow distribution; and
 - (b) contacting a process stream with the zone of reticulated
20 elements; and
 - (c) subdividing the process stream into a plurality of smaller fluid streams by passing the process stream through the plurality of flow passageways defined by the web members of the plurality of reticulated elements so that the process stream is significantly dispersed in a
25 perpendicular direction.
27. The method of claim 26 further comprising the following steps:
- (a) removing contaminants from the contaminated process stream by randomly placing the plurality of reticulated elements within the process unit thereby providing a void space between each reticulated element to
30 enhance filtration of contaminants on a surface of the plurality of reticulated elements; and

(b) providing a decontaminated and uniformly spread process stream for further processing in downstream process unit.

28. The method of claim 26, wherein the step of providing a plurality of reticulated elements includes providing the plurality of reticulated elements at a location selected from the group consisting of a process unit inlet, an interior of a process unit, a process unit outlet, and combinations thereof.

29. The method of claim 26, wherein the process unit has an inner cross-sectional configuration and the plurality of the reticulated elements are formed into an assembled sheet that, when constructed, is custom-fit to the process unit's inner cross-sectional configuration.

30. A method of filtering sediments formed within process unit, the method comprising the steps of:

(a) providing a plurality of reticulated elements in the process unit;

(b) randomly packing the plurality of reticulated elements within the process unit thereby providing a void space between a substantial number of the reticulated elements to enhance filtration of contaminants on a surface of a substantial number of the reticulated elements to produce a substantially sediment-free process stream;

(c) contacting a process stream containing the sediments with a substantial number of the reticulated elements;

(d) removing the sediments from the process stream; and

(e) providing a substantially sediment-free process stream for further processing.

31. A reactor assembly comprising a reactor, the reactor including

(a) a plurality of reticulated elements randomly packed within the reactor thereby providing a void space between a substantial number of the reticulated elements to enhance filtration of contaminants on a surface of a substantial number of the reticulated elements to produce a substantially decontaminated process stream; and

(b) a catalyst bed located downstream of the plurality of reticulated elements, the catalyst bed including an effective size of catalyst to provide an increase in catalyst activity in a range of about 15% to about 20%.

32. The reactor assembly of claim 31, wherein the plurality of reticulated elements are randomly packed throughout an entire length of a process unit.
33. The reactor assembly of claim 32, wherein the plurality of reticulated elements are commingled with catalyst over an entire length of a process unit.
- 5 34. A method of removing contaminants from a contaminated process stream comprising the steps of:
- (a) providing a plurality of ceramic monoliths in a chemical reactor;
 - 10 (b) randomly packing the plurality of ceramic monoliths within the chemical reactor thereby providing a void space between a substantial number of the ceramic monoliths to enhance filtration of contaminants on a surface of a substantial number of the ceramic monoliths to produce a substantially decontaminated process stream; and
 - 15 (c) contacting the contaminated process stream with a substantial number of the ceramic monoliths to remove contaminants from the contaminated process stream while allowing the substantially decontaminated process stream to pass unimpeded through the plurality of ceramic monoliths.

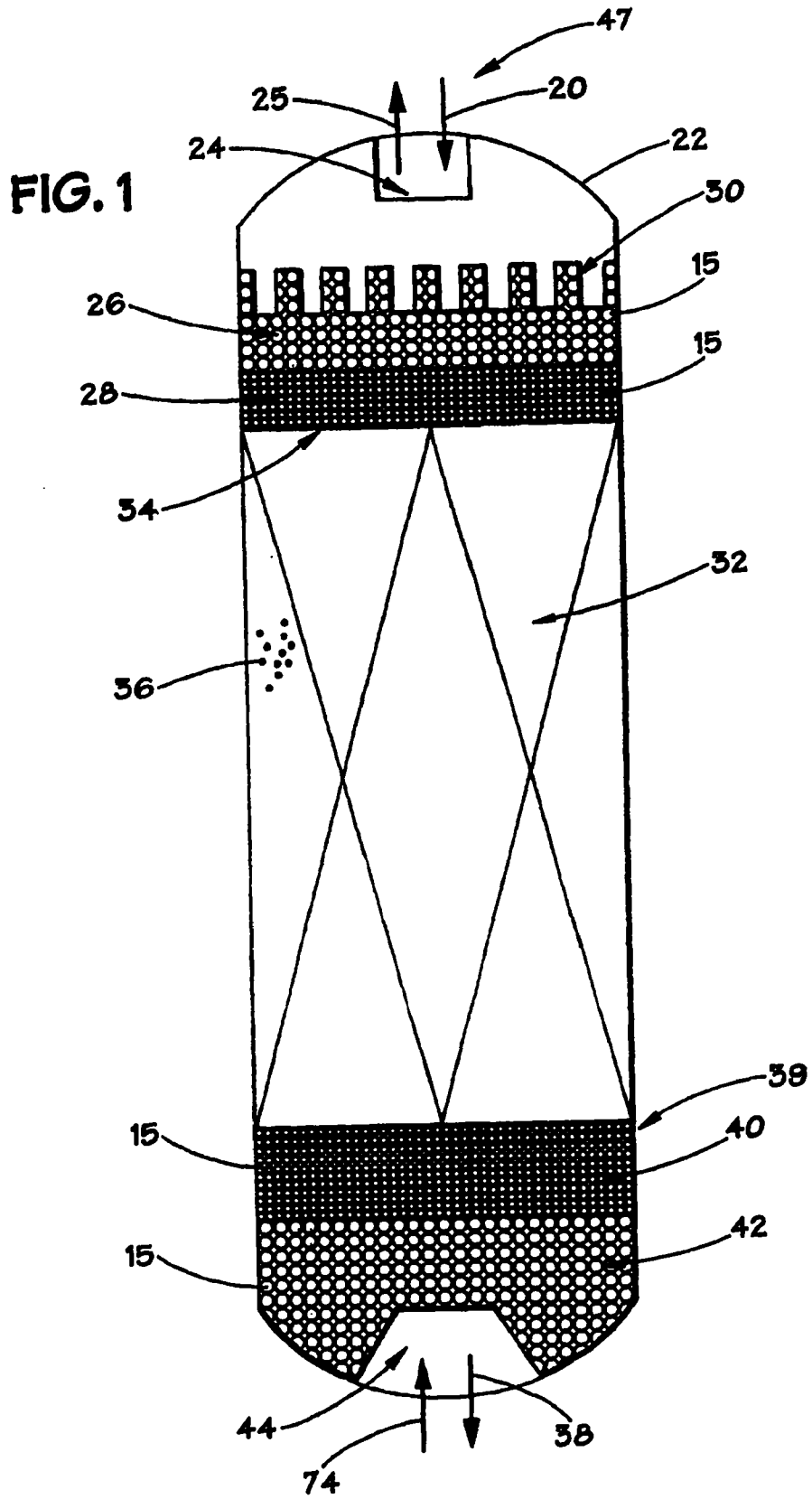

FIG. 2

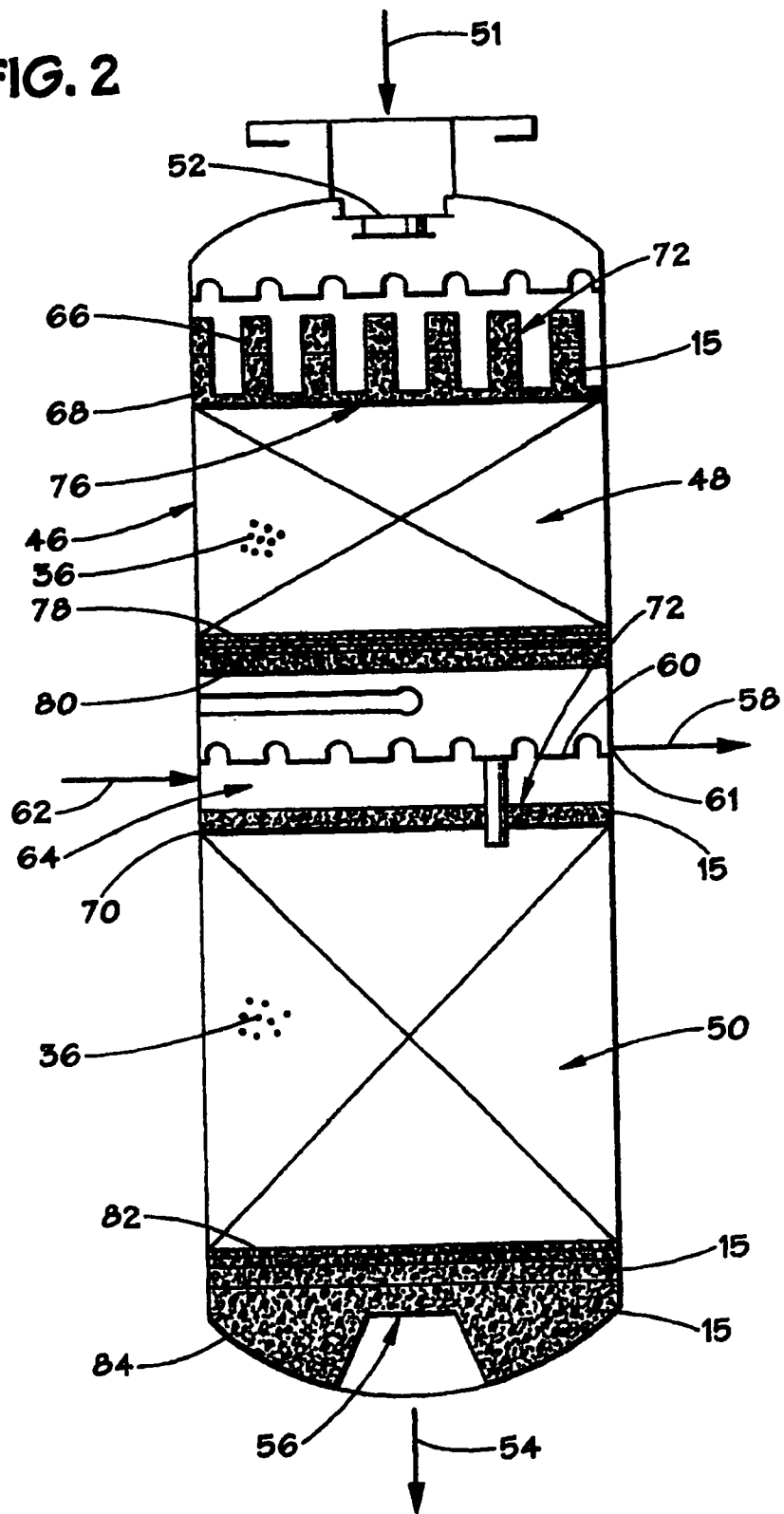

FIG. 3

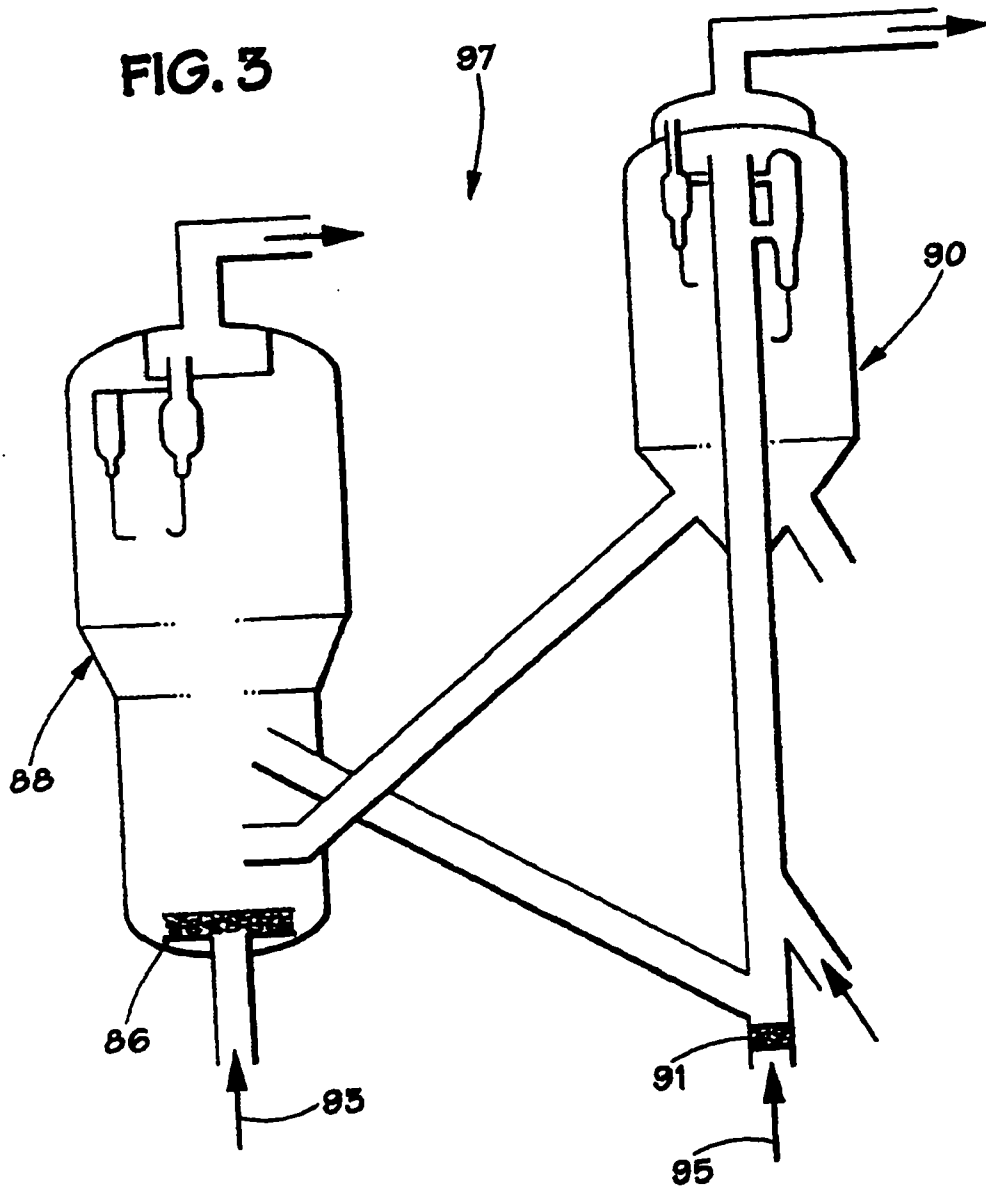

FIG. 4

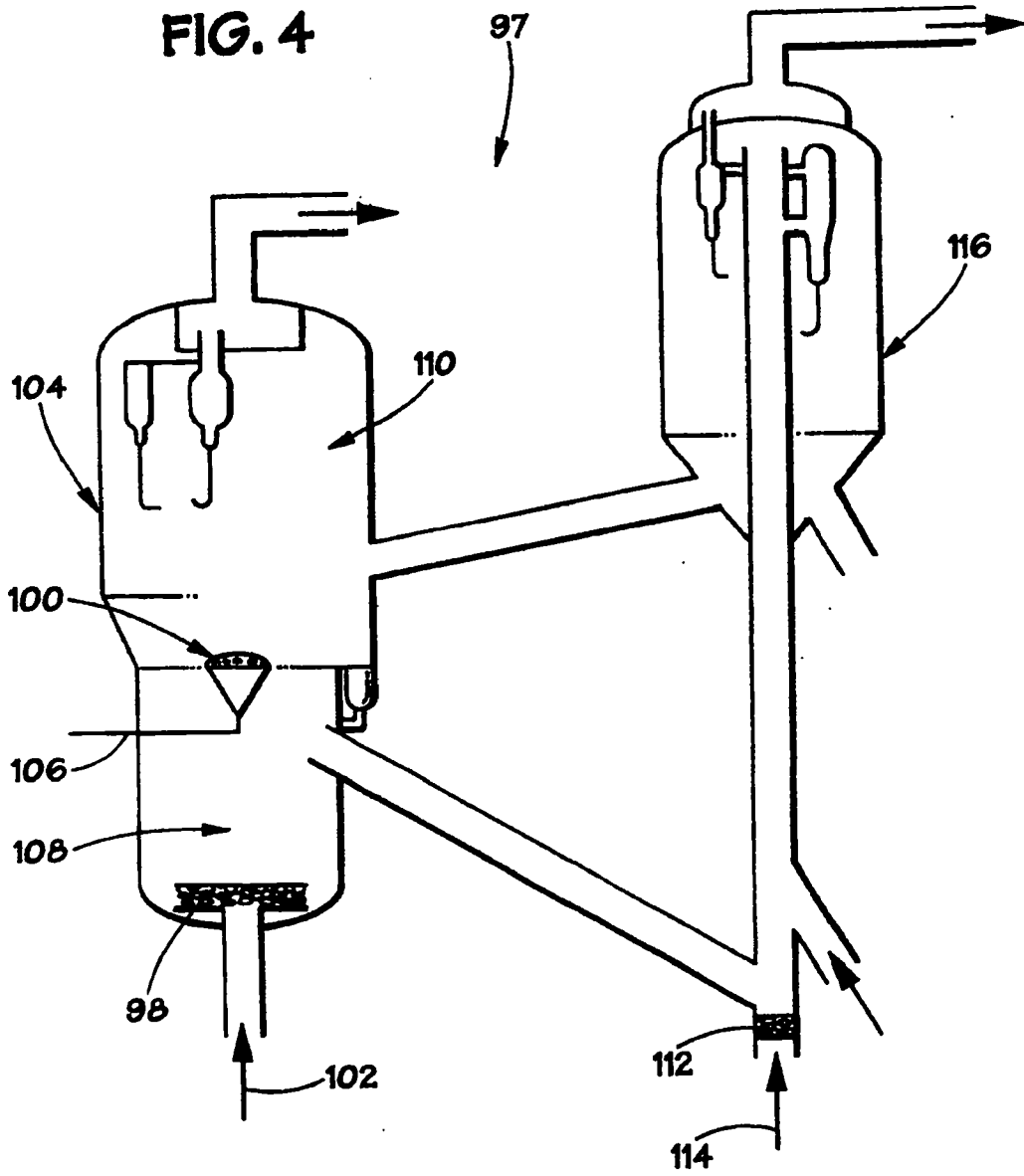
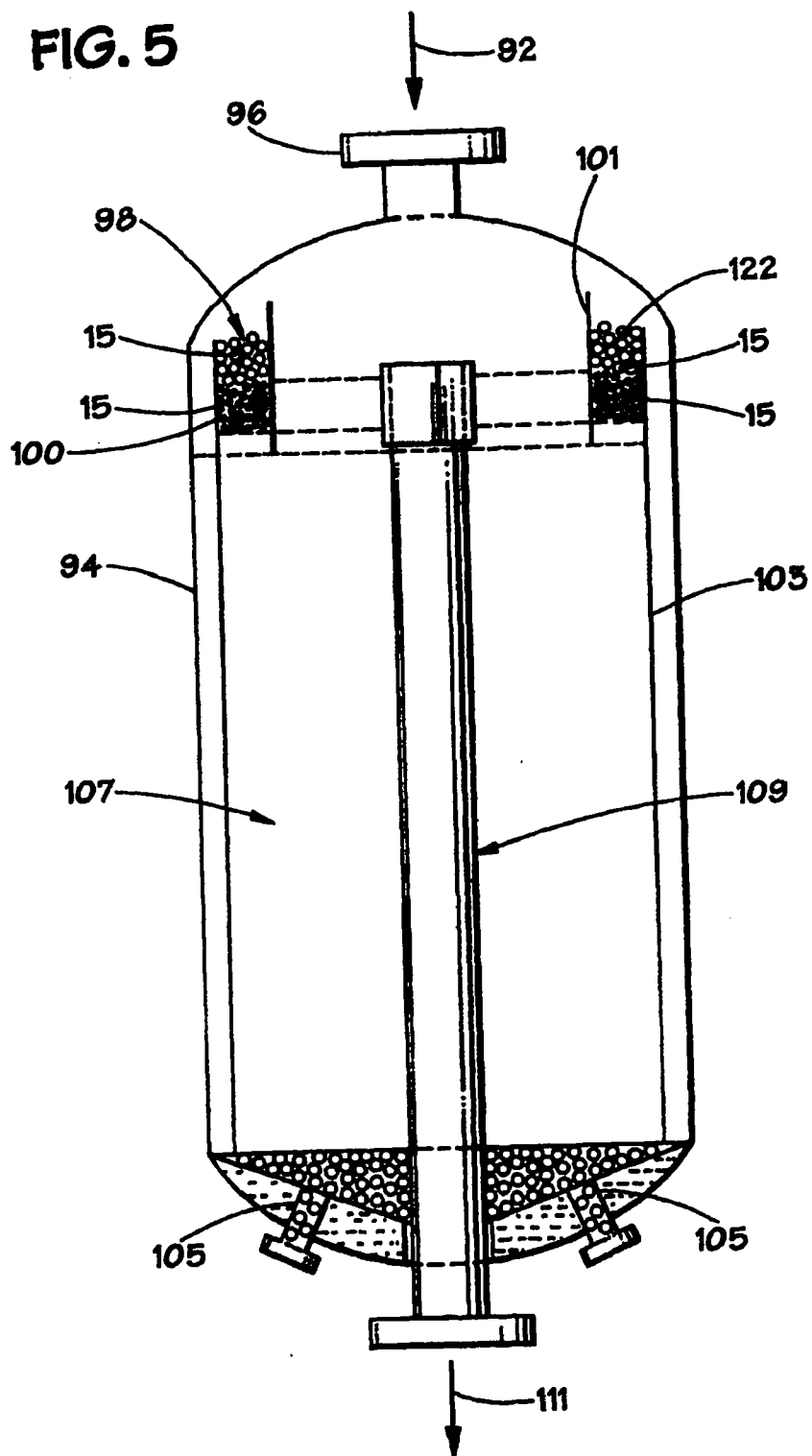

FIG. 5



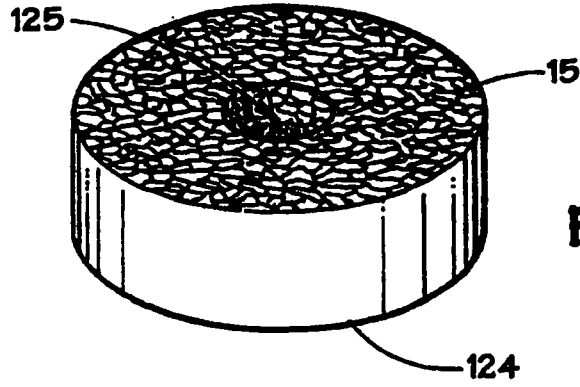

FIG. 6

FIG. 7

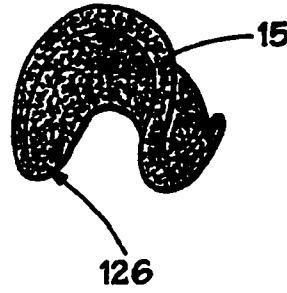

FIG. 8

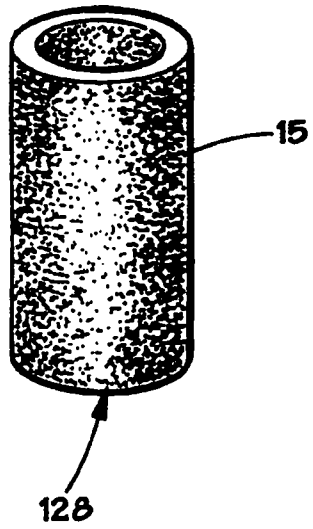
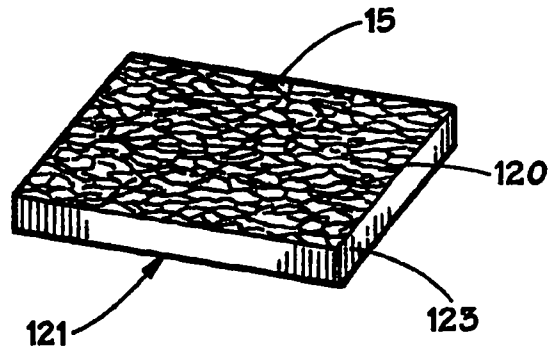

FIG. 9



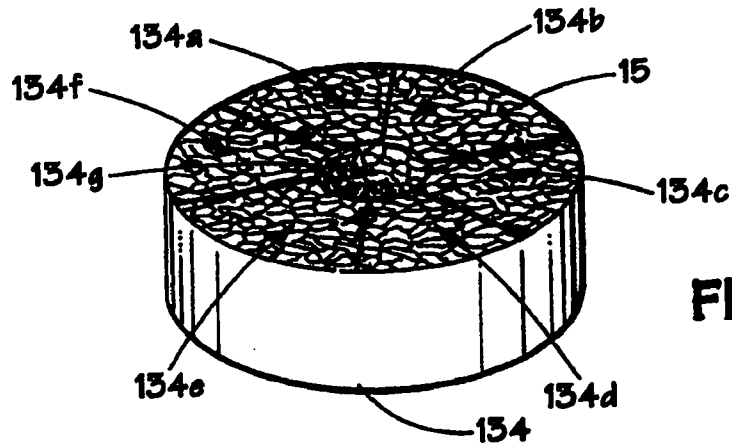

FIG. 10

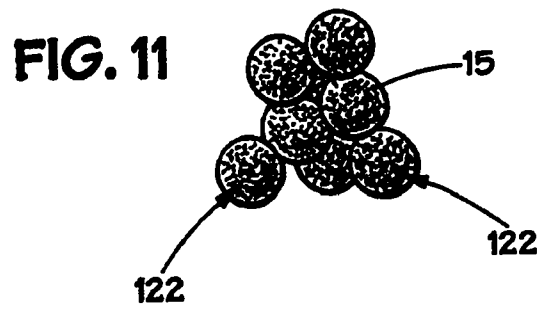

FIG. 11

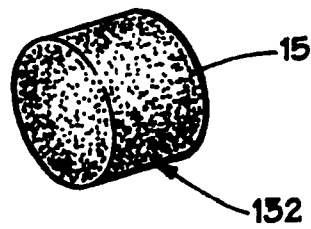
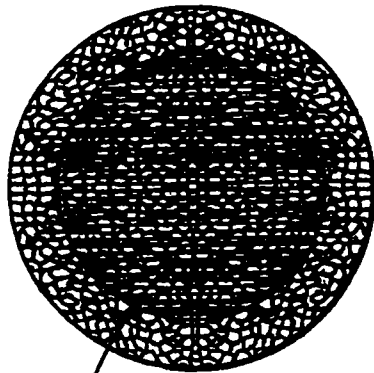
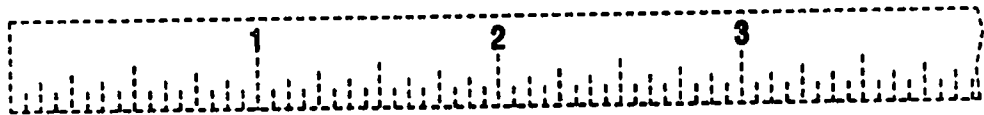
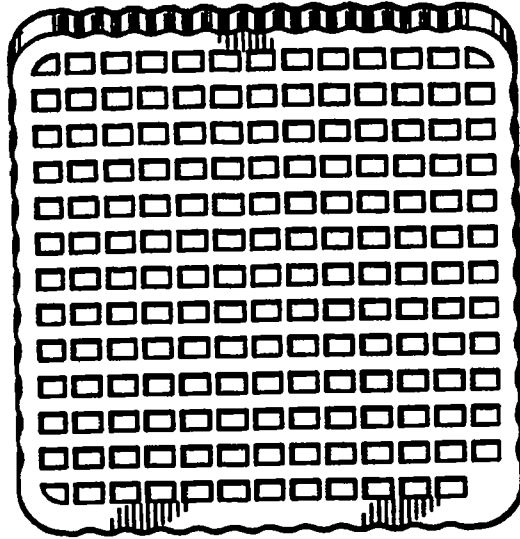

FIG. 12

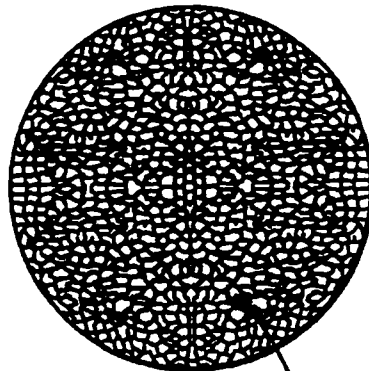

FIG. 13

FIG. 14



**DYE DRIPPED ON THIS
SIDE OF DISK**



**BOTTOM OF DISK AFTER
DYE RAN THROUGH**

FIG. 21

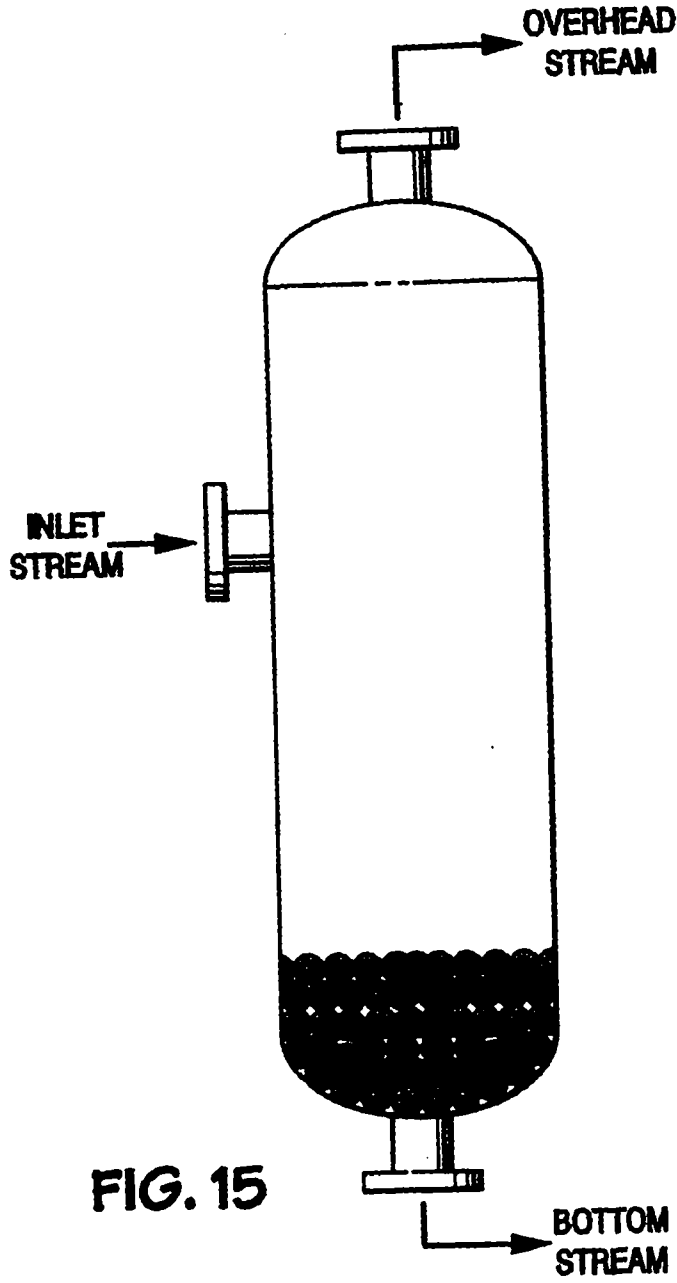

FIG. 19

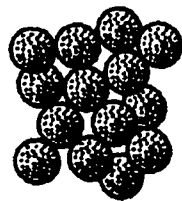
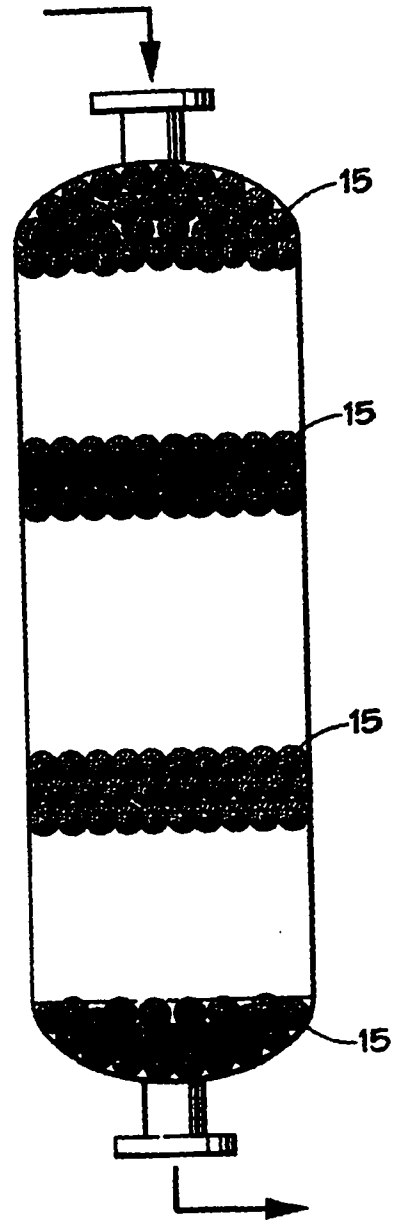
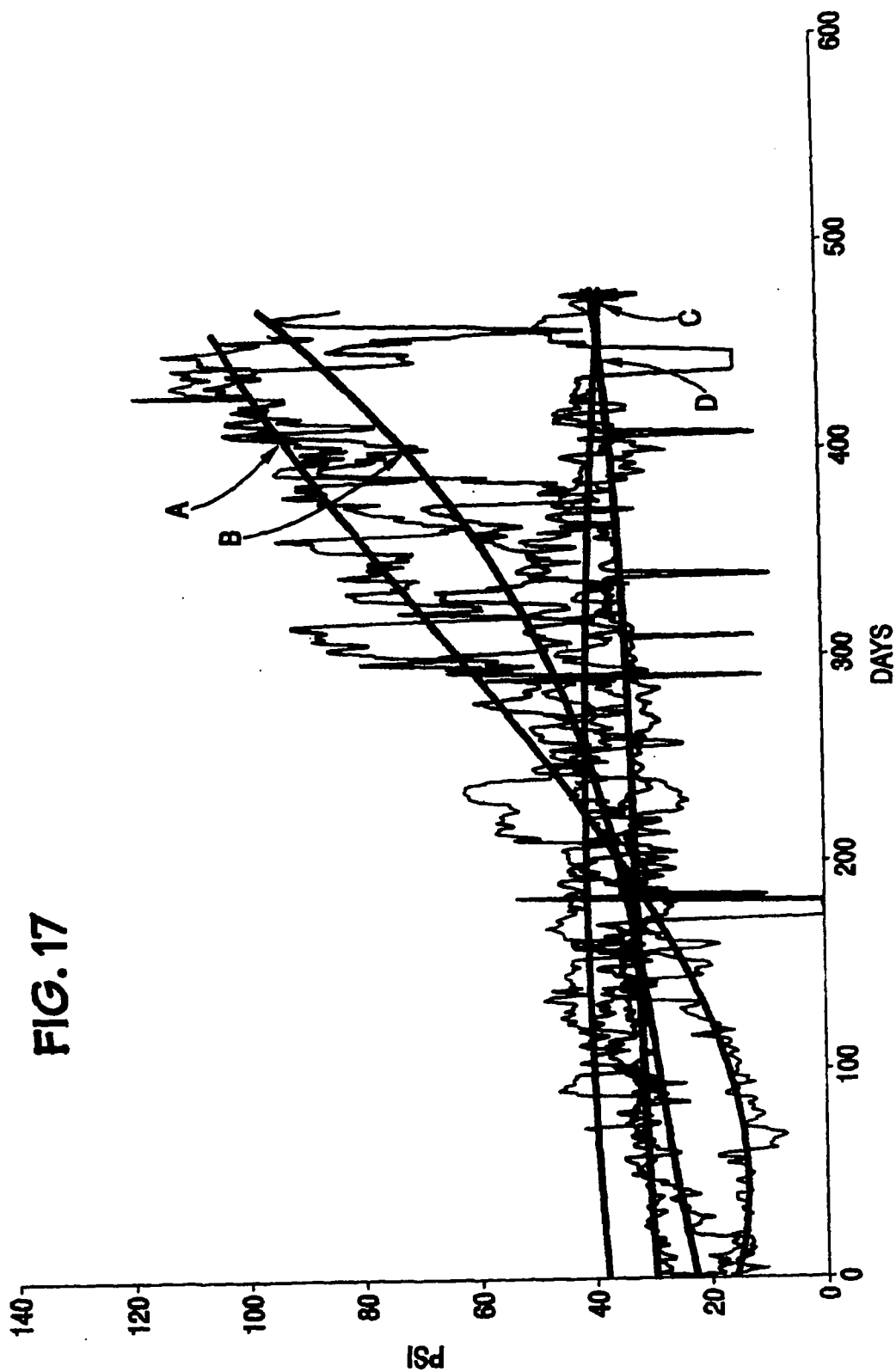

FIG. 16



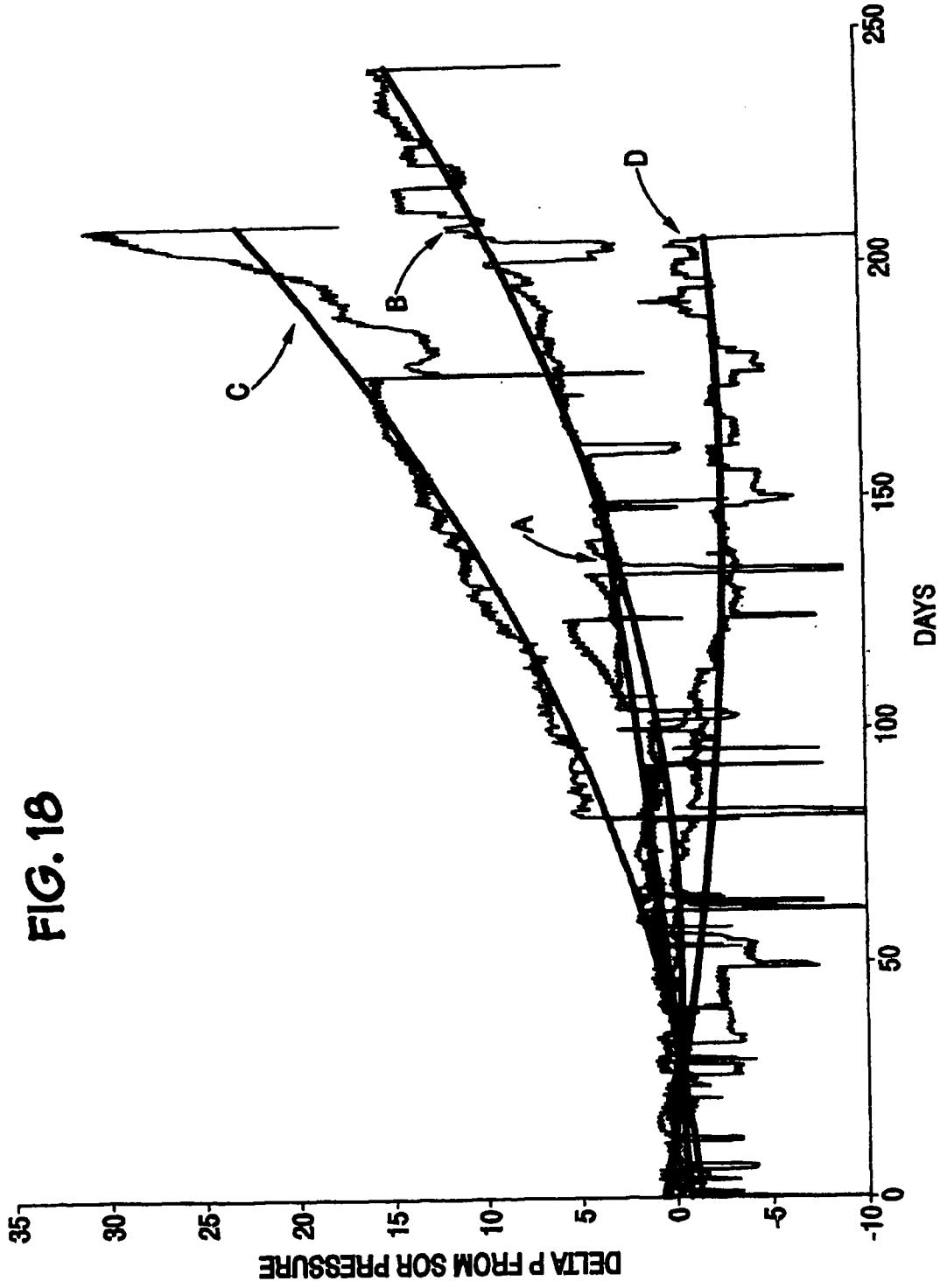

FIG. 18

