

(No Model.)

2 Sheets—Sheet 1.

E. B. GOODWIN.
ROASTING FURNACE.

No. 527,746.

Patented Oct. 16, 1894.

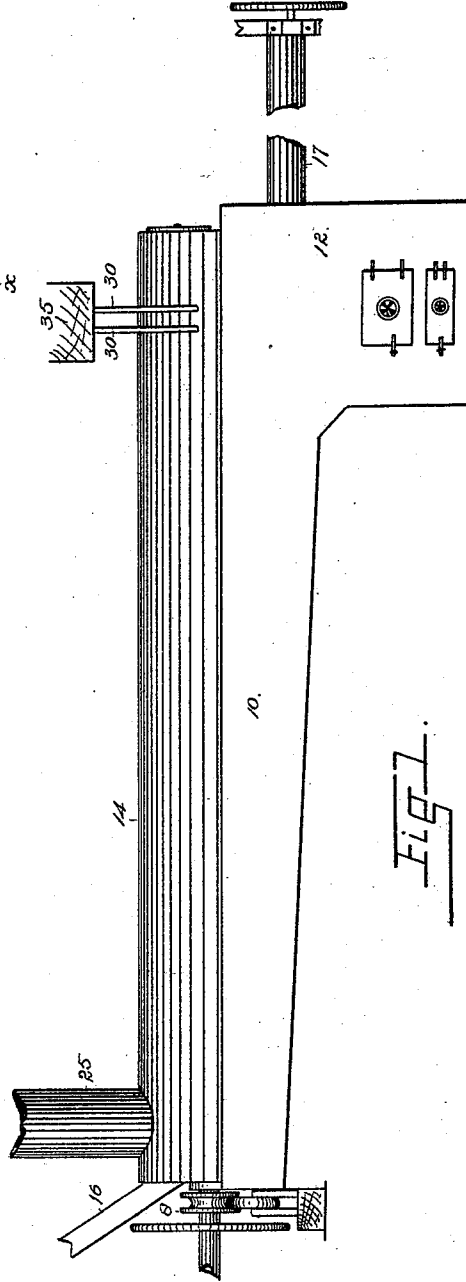
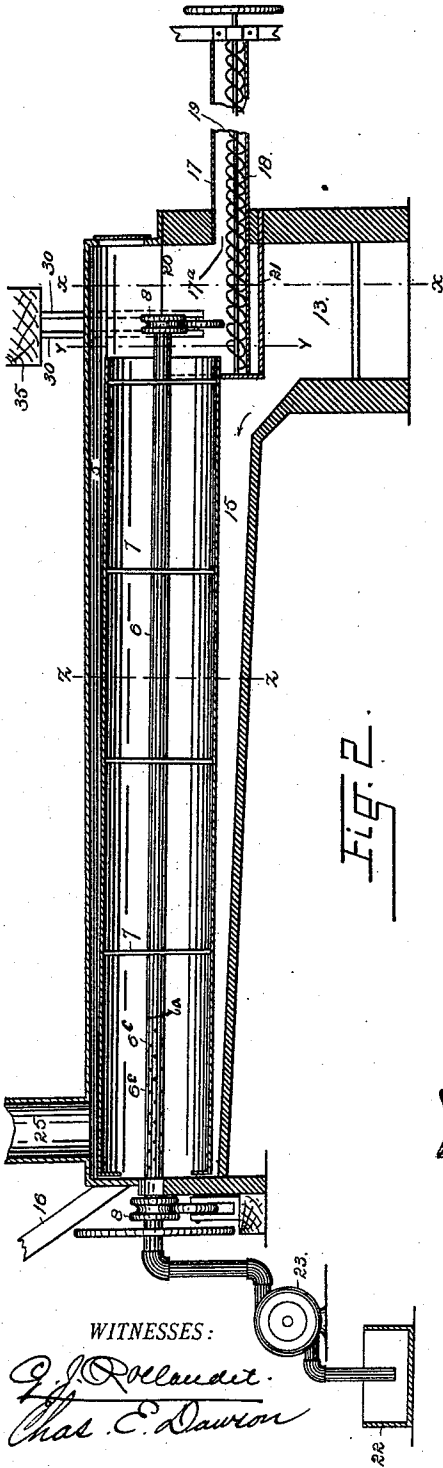

WITNESSES:

E. J. O'Connell
Chas. E. Dawson

INVENTOR

Edwin B. Goodwin
BY
A. J. Brown
ATTORNEY

(No Model.)

2 Sheets—Sheet 2.

E. B. GOODWIN.
ROASTING FURNACE.

No. 527,746.

Patented Oct. 16, 1894.

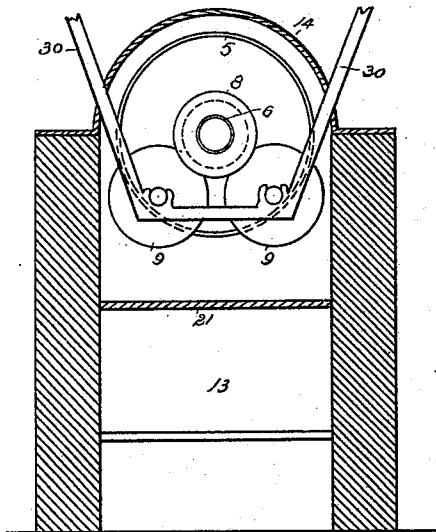

Fig. 4

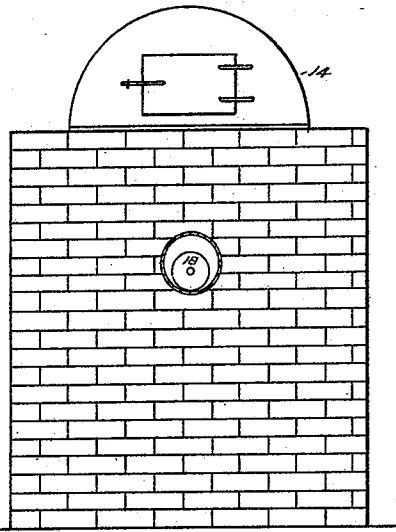

Fig. 3

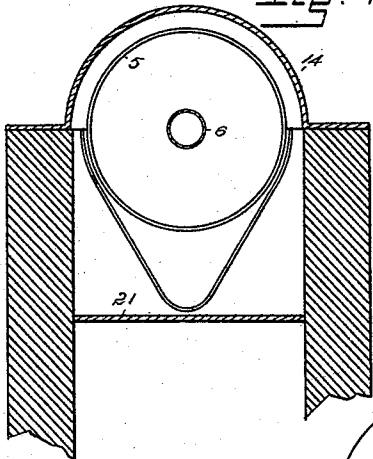

Fig. 5

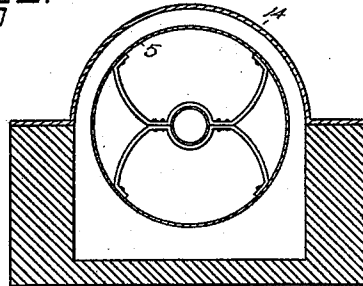

Fig. 6

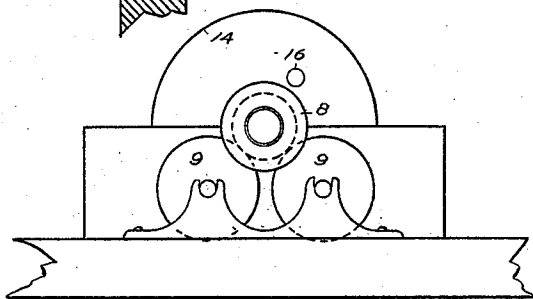

Fig. 7

WITNESSES:

G. J. Dollander.
Chas. E. Dawson.

INVENTOR

Edwin B. Goodwin

BY

A. J. Brien

ATTORNEY

UNITED STATES PATENT OFFICE.

EDWIN B. GOODWIN, OF BOULDER, COLORADO.

ROASTING-FURNACE.

SPECIFICATION forming part of Letters Patent No. 527,746, dated October 16, 1894.

Application filed December 5, 1893. Serial No. 492,812. (No model.)

To all whom it may concern:

Be it known that I, EDWIN B. GOODWIN, a citizen of the United States of America, residing at Boulder, in the county of Boulder and State of Colorado, have invented certain new and useful Improvements in Roasting-Furnaces; and I do declare the following to be a full, clear, and exact description of the invention, such as will enable others skilled in the art to which it appertains to make and use the same, reference being had to the accompanying drawings, and to the figures of reference marked thereon, which form a part of this specification.

My invention relates to improvements in ore roasting furnaces, the ultimate object being the same as that sought to be accomplished by all furnaces of this class, namely, the separation from the ore by heat-volatilization of certain elements such as sulphur, arsenic, &c., whereby the ore is prepared for subsequent treatment, as by amalgamation, to the end that the precious metals may be separated therefrom. Hence, my improved roaster consists of the features, arrangements and combinations hereinafter described and claimed, all of which will be fully understood by reference to the accompanying drawings in which is illustrated an embodiment thereof.

In the drawings, Figure 1 is a side elevation of the furnace. Fig. 2 is a longitudinal section taken therethrough. Fig. 3 is an end elevation of the furnace. Figs. 4, 5 and 6 are sections taken on the lines $x-x$, $y-y$, and $z-z$, respectively, Fig. 2. Fig. 7 is an end elevation of the feed extremity of the furnace.

Similar reference characters indicating corresponding parts or elements of the mechanism in the several views, let the numeral 5 designate a hollow, rotatable cylinder or drum mounted upon a hollow shaft 6 passing through its longitudinal center. This shaft is connected with the interior walls of the cylinder by spiders 7, and projects from the cylinder at both extremities which are provided with collars 8 for the engagement of the friction disks 9 which are journaled in suitable stationary supports. This roasting cylinder is partly inclosed by walls 10 which are continuous with the walls 12 inclosing the fire chamber 13. The upper portion of the cylinder is protected by a suitable cover 14

formed of some material which is a poor conductor of heat, the object being to confine the heat in the roasting chamber 15 through which the cylinder passes, until it has traversed the entire length of said chamber. The pulverized ore is fed to the cylinder from any suitable ore bin or receptacle (not shown) through a chute 16. From this feed extremity the cylinder is inclined downward to its discharge extremity, which is lowest. This inclination of the cylinder is such as to cause the ore to travel through the cylinder from the feed to the discharge extremity, but it must be so regulated that the ore shall be retained within the cylinder a sufficient length of time to deprive it of those impurities of the class heretofore mentioned, and which readily volatilize when subjected to heat.

From the discharge extremity of the furnace, the ore passes to a pipe 17 in which is located a screw conveyer 18 whose extremities are journaled at the ends of the pipe. The diameter of the conveyer is somewhat less than that of the pipe in which it is located, whereby a space 19 is left in the upper part of the pipe for the passage of cold air which is admitted at the outer extremity of the pipe. This air while passing through the pipe 17 aids in cooling the ore which has left the roasting cylinder. From pipe 17, the air passes to the hot air chamber 20 located above the fire chamber and separated therefrom by a metal partition 21. The pipe 17 is provided with an outlet opening 17^a whence the air passes to the chamber 21, and thence into the discharge extremity of the roasting cylinder which is also located within chamber 20. This air previous to entering the roasting cylinder, has become heated in chamber 20, but is not subjected in this chamber to a degree of heat sufficient to deprive it of any of its oxygen. Hence when this air enters the roasting cylinder, it supplies the ore therein with the necessary amount of oxygen for roasting purposes.

The hollow shaft 6 is closed at a point 6^a near the outer extremity of the cylinder, and from this point to the adjacent end of the cylinder it is perforated as shown at 6^c for the entrance of vapors released by the roasting process, and whence they are carried and discharged into a condensing tank 22 contain-

ing water, through the agency of suitable suction inducing and air compression mechanism 23 suitably connected with the outer extremity of the hollow shaft 6 and located 5 between the said shaft extremity and the tank 22.

The object of the condensing tank is to save that portion, if any, of the precious metals which have become volatilized during the 10 roasting process.

The suction inducing or blowing mechanism 23, besides the function heretofore stated, causes a continuous draft of air from the outer extremity of pipe 17 through the space 15 19 in said pipe, thence through the hot air chamber 20, and thence through the roasting cylinder.

It will be observed that the air in chamber 20 is heated only by radiation from the partition 21, since this chamber is closed against the entrance of heated gases from the fire chamber 13, since the heated gases from the last named chamber do not enter the interior of the roasting cylinder, but are confined to 25 the chamber 15, and only come in contact with the exterior surface of said cylinder.

The stack 25, connected with the chamber 15, is for the escape of the ordinary products of combustion.

The friction disks 9 located at the discharge end of the roasting cylinder, are journaled and supported in a double yoke-shaped frame 30, the parts of which are made fast to a stationary support 35 suitably located 30 above the furnace.

Having thus described my invention, what I claim is—

1. In an ore-roasting furnace, the combination of the roasting chamber connected with 40 a suitable source of heat, the hollow cylinder rotatably mounted in said chamber and inclined downward from the feed to its discharge extremity, a hot air chamber surrounding the discharge extremity of the cylinder and separated from the source of heat whence it receives heat only by radiation, and an ore 45

discharge pipe connected with the hot air chamber and open to receive the ore from the roasting cylinder, said pipe being provided with a conveyer, and an air passage forming 50 the supply for the hot air chamber, and suitable suction inducing mechanism connected with the outer extremity of the cylinder, substantially as described.

2. In an ore-roasting furnace, the combination of the roasting chamber connected with 55 a suitable source of heat, the hollow inclined cylinder rotatably mounted in said chamber, said cylinder being provided with a hollow perforated shaft, a hot air chamber at the discharge extremity of the cylinder, said chamber being separated from the source of heat, but located in suitable proximity thereto, a discharge pipe having one extremity located 60 within the hot air chamber for the reception of the ore from the cylinder, said pipe having a conveyer and an air passage for supplying the hot air chamber, suitable suction inducing mechanism connected with the outer extremity of the hollow shaft of the cylinder, 65 and a condensing tank, substantially as described.

3. In an ore roasting furnace, the combination of the roasting chamber connected with a suitable source of heat, a hollow cylinder rotatably mounted in said chamber, the hot air 75 chamber surrounding the discharge extremity of the cylinder, and separated from the source of heat which it receives only by radiation, and an ore discharge pipe connected with the hot air chamber, and open to receive 80 the air from the roasting cylinder, said pipe being provided with a conveyer and an air passage forming the supply for the hot air chamber, substantially as described. 85

In testimony whereof I affix my signature in the presence of two witnesses.

EDWIN B. GOODWIN.

Witnesses:

G. J. ROLLANDET,
CHAS. E. DAWSON.