



US00D357712S

United States Patent [19]

[11] Patent Number: Des. 357,712

Wu

[45] Date of Patent: ** Apr. 25, 1995

[54] VIDEO GAME CONTROL UNIT

OTHER PUBLICATIONS

[76] Inventor: **James Wu**, No. 40, Yuan Tan Rd., Yuan Lin Chen, Chang Hua Hsien, Taiwan, Prov. of China

Merchandizing, Feb. 1983, p. 58.
Playthings, Sep. 1988, p. 50.
Hongkong Enterprise Oct. 1990, p. 813.

[**] Term: **14 Years**

Primary Examiner—Prabhakar G. Deshmukh
Attorney, Agent, or Firm—Varndell Legal Group

[21] Appl. No.: **16,992**

[57] CLAIM

[22] Filed: **Jan. 3, 1994**
[52] U.S. Cl. **D21/48**
[58] Field of Search D21/13, 48;
273/433-438, 148 B, DIG. 28; D14/100, 114

The ornamental design for video game control unit, as shown and described.

DESCRIPTION

[56] **References Cited**

U.S. PATENT DOCUMENTS

D. 317,946 7/1991 Tse D21/48
D. 317,948 7/1991 Tse D21/48
D. 340,479 10/1993 Ho D21/48
4,509,383 4/1985 Yeh 273/438 X
4,658,666 4/1987 Liu 273/438 X

FIG. 1 is a perspective view of video game control unit showing my new design thereof;
FIG. 2 is a front elevational view thereof;
FIG. 3 is a rear elevational view thereof;
FIG. 4 is a left side elevational view thereof;
FIG. 5 is a right side elevational view thereof;
FIG. 6 is a top plan view thereof; and,
FIG. 7 is a bottom plan view thereof.

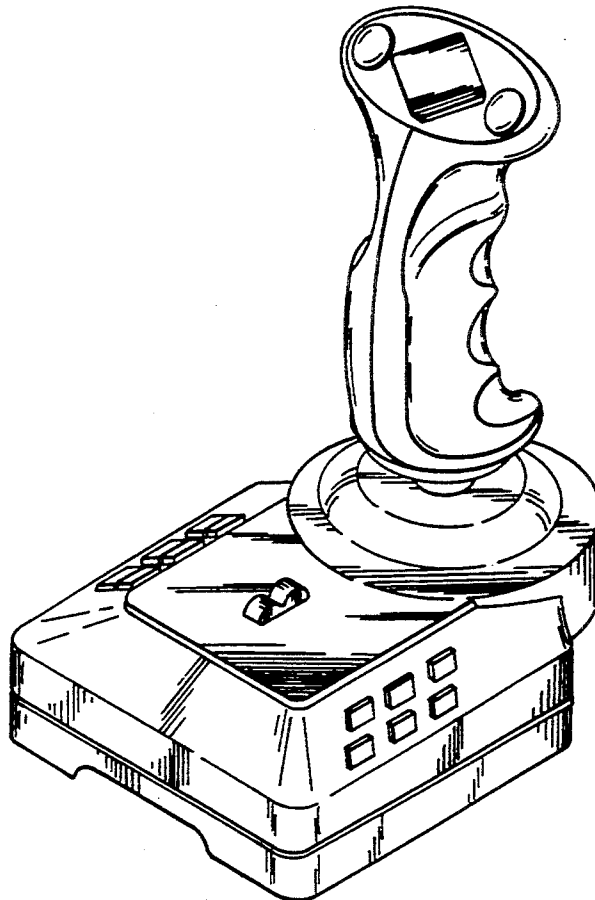

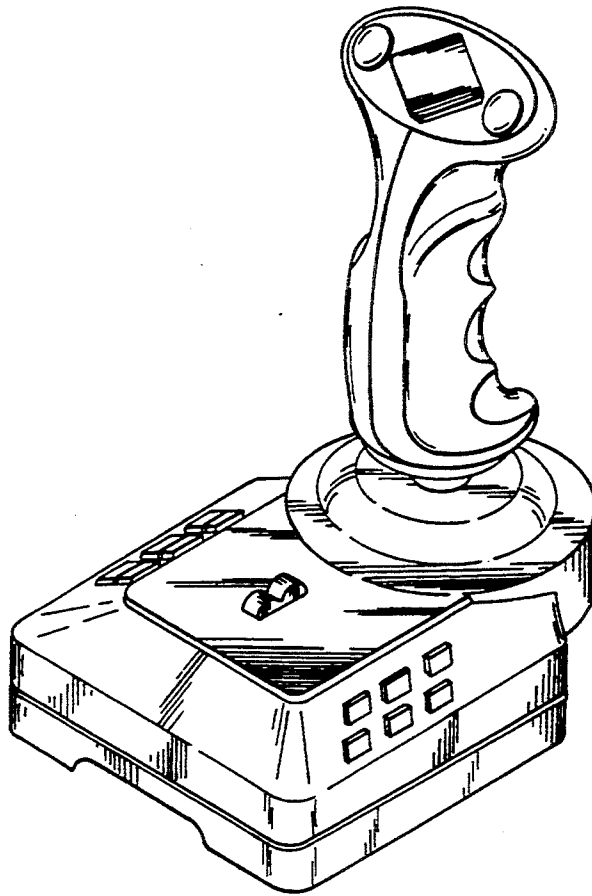

FIG. 1

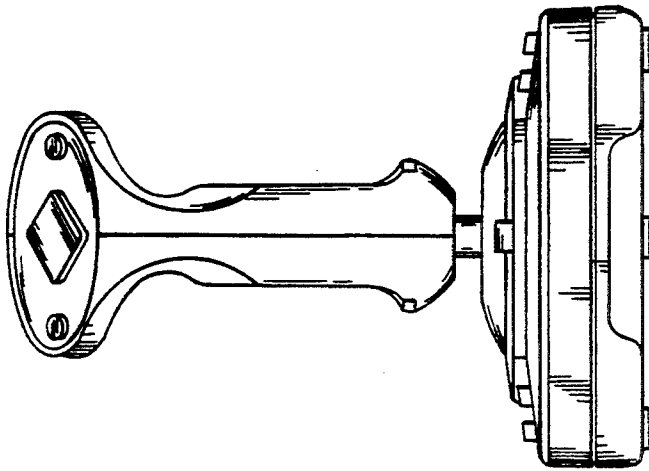

FIG.3

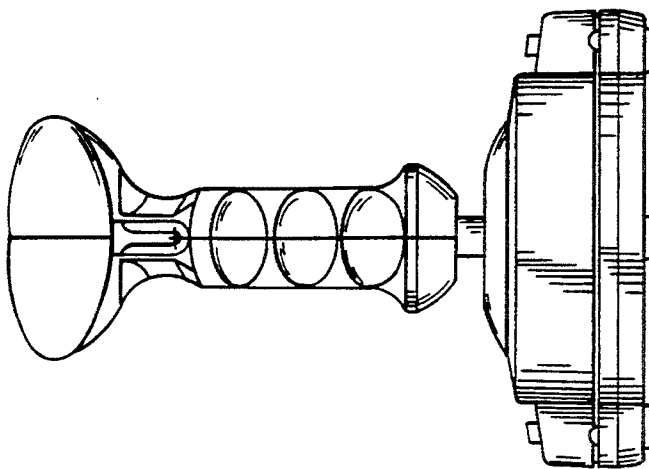

FIG.2

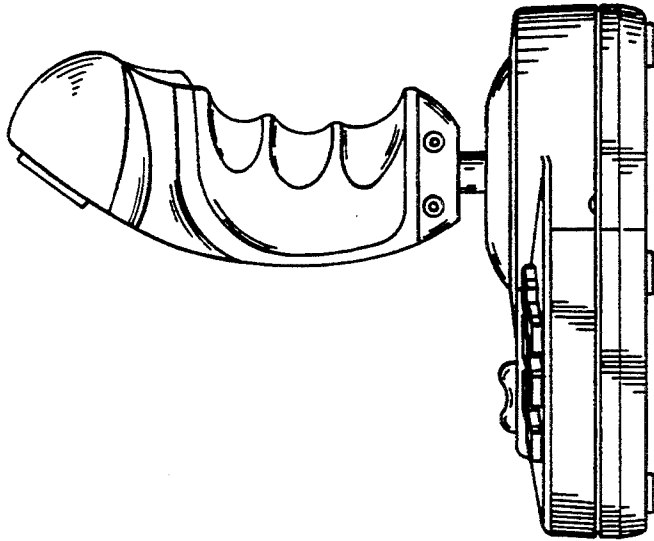

FIG.5

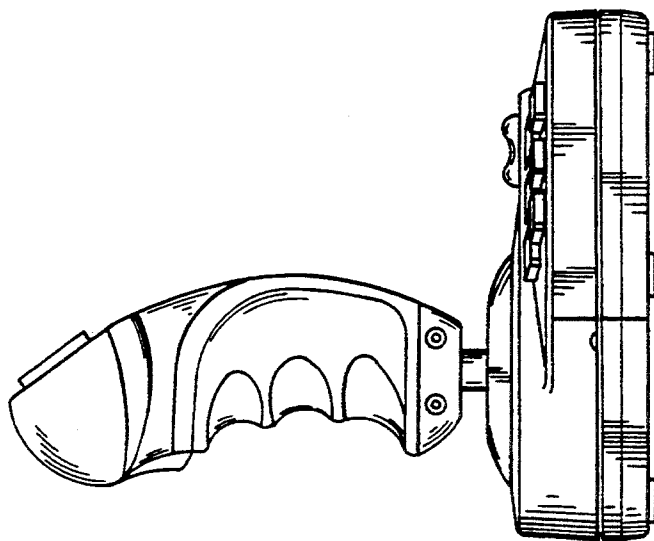

FIG.4

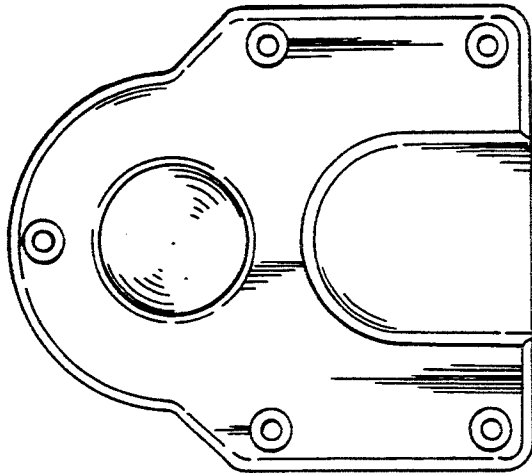

FIG. 7

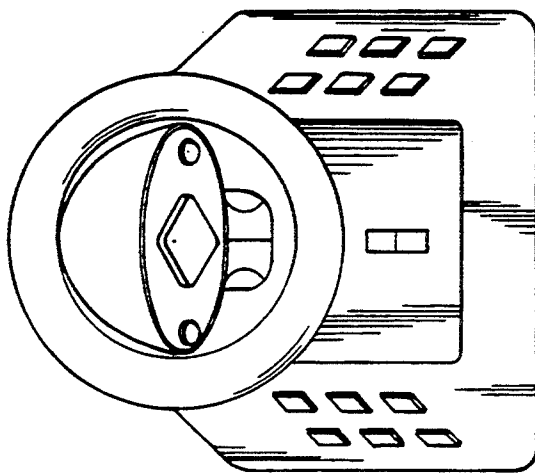

FIG. 6