

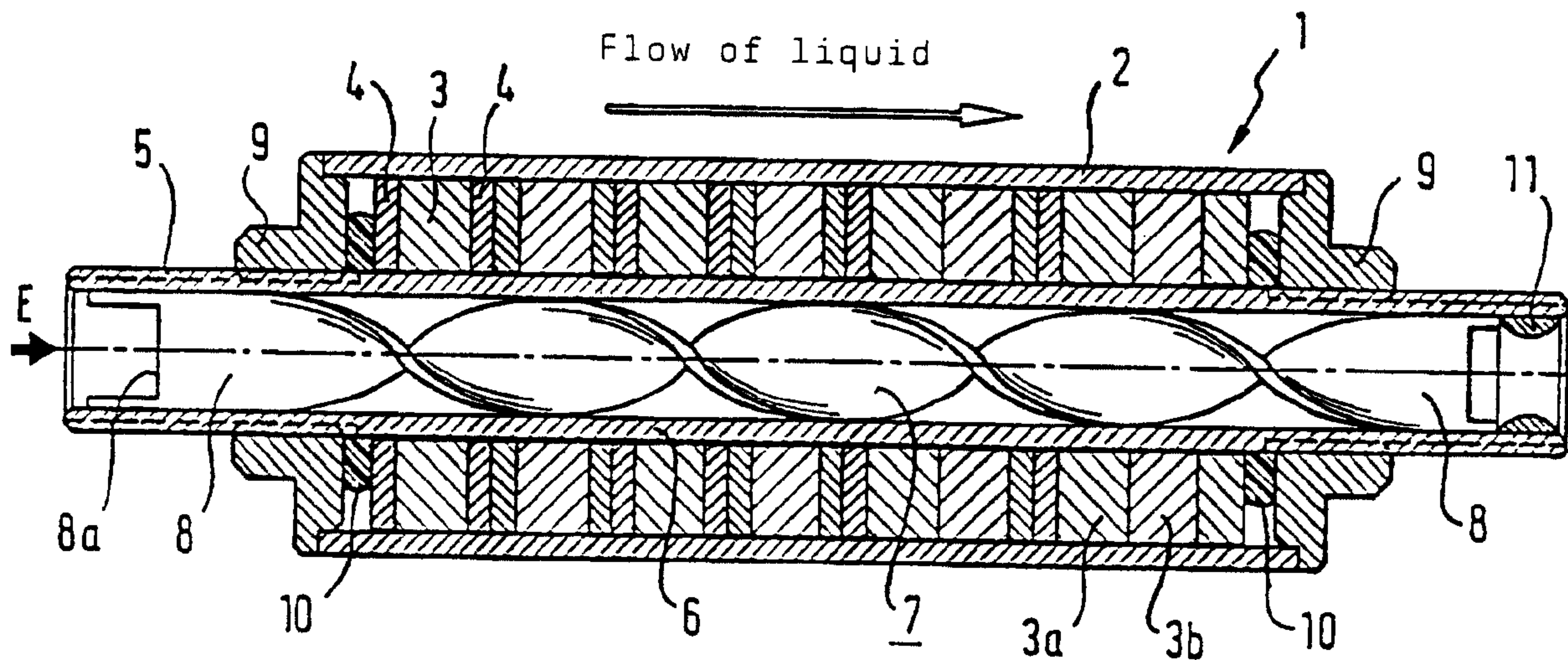

(86) Date de dépôt PCT/PCT Filing Date: 1999/09/02
 (87) Date publication PCT/PCT Publication Date: 2001/03/02
 (85) Entrée phase nationale/National Entry: 2002/05/31
 (86) N° demande PCT/PCT Application No.: EP 1999/006454
 (87) N° publication PCT/PCT Publication No.: 2001/017913

(51) Cl.Int.⁷/Int.Cl.⁷ C02F 1/48
 (71) Demandeur/Applicant:
 JANS, MANFRED ERNST, DE
 (72) Inventeur/Inventor:
 JANS, MANFRED ERNST, DE
 (74) Agent: BORDEN LADNER GERVAIS LLP

(54) Titre : APPAREIL DE TRAITEMENT DE LIQUIDE PAR AIMANT PERMANENT
 (54) Title: PERMANENT MAGNETIC LIQUID TREATING DEVICE



(57) Abrégé/Abstract:

The invention relates to a permanent magnetic liquid treatment device (1), comprising a tubular housing (2) in which ring magnets (3) and magnetizable spacer discs (4) are located, coaxially to the longitudinal axis of the housing, and which has contact pieces (5) at both ends. The device also has mechanisms which produce a screw motion in the liquid passing through and an inner tube (6) which is located in the housing, coaxially to the longitudinal axis thereof and at a distance from the inner housing wall. The liquid to be treated flows through said inner tube and the ends of the inner tube are liquid-tightly connected to the contact pieces (5). The ring magnets (3) and the spacer discs (4) are installed in the liquid-free area between the inner tube (6) and the tubular housing (2) in such a way that they lie one behind the other in the direction of the longitudinal axis of the housing. The tubular housing (2) consists of a non-magnetizable material. The inner tube (6) and the contact pieces (5), which form a single piece with the same, consist of a magnetizable, non-rusting metal. A strip (7) which is coiled 1 to 3 times and consists of a magnetizable, non-rusting metal, is fixed in the inner tube, the width of said strip corresponding to the inner diameter of the inner tube (6). Ring magnets (3) and spacer discs (4) are arranged in a stack in the liquid-tight ring area between the housing (2) and the inner tube (6). This stack is held in place in such a way that it cannot move and is tightly enclosed by means of sleeves (9) screwed onto the contact pieces (5).

ABSTRACT

The invention relates to a permanent magnetic liquid treatment device (1), comprising a tubular housing (2) in which magnets (3) and magnetizable spacer discs (4) are located, coaxially to the longitudinal axis of the housing, and which has contact pieces (5) at both ends. The device also has mechanisms which produce a screw motion in the liquid passing through and an inner tube (6) which is located in the housing, coaxially to the longitudinal axis thereof and at a distance from the inner housing wall. The liquid to be treated flows through said inner tube and the ends of the inner tube are liquid-tightly connected to the contact pieces (5). The ring magnets (3) and the spacer discs (4) are installed in the liquid-free area between the inner tube (6) and the tubular housing (2) in such a way that they lie one behind the other in the direction of the longitudinal axis of the housing. The tubular housing (2) consists of a non-magnetizable material. The inner tube (6) and the contact pieces (5), which form a single piece with the same, consist of a magnetizable, non-rusting metal. A strip (7) which is coiled 1 to 3 times and consists of a magnetizable, non-rusting metal, is fixed in the inner tube, the width of said strip corresponding to the inner diameter of the inner tube (6). Ring magnets (3) and spacer discs (4) are arranged in a stack in the liquid-tight ring area between the housing (2) and the inner tube (6). This stack is held in place in such a way that it cannot move and is tightly enclosed by means of sleeves (9) screwed onto the contact pieces (5).

Permanent magnetic liquid treating device

The invention relates to a permanent magnetic liquid treating device comprising a tubular housing in which ring magnets and magnetizable spacer discs are located, coaxially to the longitudinal axis of the housing, and which has connecting pieces at both ends, said device comprising means which cause a spiral motion of the liquid passing therethrough, and an inner tube which is located in the housing, coaxially to the longitudinal axis thereof and at a distance from the inner wall of the housing, the ends of said inner tube being connected liquid-tight to said connecting pieces, and the ring magnets and spacer discs being installed in the liquid-free space between the inner tube and the tubular housing so that they lie one behind the other in the direction of the longitudinal axis of the housing

A permanent magnetic liquid treating device of this kind is known by DE 195 32 357 A1 and this document forms the basis of the pre-characterizing part of claim 1. Such devices, which are also known from other patent documents, are used especially for the magnetic treatment of water in order to avoid the formation of lime deposits at the inner wall of pipes and tanks by causing that the calcium carbonate which is dissolved in the water is deposited not at the walls but in the form of separable fine particles.

While the treating device referred to above is in principle suitable for this purpose, its effect is not yet fully satisfactory. The rotating turbine which in the known device is used for creating a spiral motion of the liquid flowing therethrough can not provide for a spiral motion which is constant over the total length of the device, and the construction of the known device furthermore causes an undesirable higher pressure drop.

The object of the invention is therefore to improve a treating device of the above described type in such way that its construction is simplified and its effectiveness is clearly improved, that is that the formation of scale in pipes and tanks through which tap water flows but also in the liquid circulation of for example boilers or washing machines is avoided to an even higher degree.

This object is achieved by the dispositions of the characterizing part of claim 1. Preferred embodiments are described in the dependent claims.

By the cooperation of the specific coaxial arrangement of a stack of cylindrical ring magnets which are separated from each other by spacer discs consisting of metal and which surround an inner tube, with a helically wound strip consisting of a magnetizable rustproof metal, the width of which corresponds to the inner diameter of the inner tube and which is arranged in said inner tube, the desired helical motion of the liquid flowing therethrough is realized in an even manner and practically without pressure drop and without moving parts, and an improvement of the magnetic flow which acts upon the molecules of the water flowing there-through is achieved. The device according to the invention is of notably simple construction and can be manufactured at low costs.

Further features and advantages of the invention will become apparent by the following description of an embodiment, by way of example, and without limitation, referring to the attached drawings which show:

- Fig. 1 a schematical view of an axial longitudinal section of a liquid treating device according to the invention, the strip being shown in side view;
- Fig. 2 the arrangement of the ring magnets of fig. 1 without the housing and inner tube;
- Fig. 3 and 4 a detail of two other embodiments of the inlet terminal part of the strip of the device of fig. 1.

The permanent magnetic liquid treating device 1 shown in fig. 1 comprises a tubular housing 2 in which ring magnets 3 and magnetizable spacer discs 4 are arranged coaxially to the longitudinal axis of the housing and which at both ends comprises connecting pieces 5 which are formed in one piece with the inner tube 6 and form an extension thereof. The tubular housing 2 consists of a non-magnetizable material, here an aluminium alloy, while the inner tube 6 and the tubular connecting pieces 5 consists of a magnetizable rustproof metal, here special (stainless) steel, and the ring magnets and spacer discs are mounted one behind the other in form of a stack in the liquid-free space between the inner tube and the tubular housing. The stack is held unmovable and tightly enclosed in the housing by terminal sleeves 9 which are screwed on the connecting pieces 5 from both sides, an elastic sealing ring (O-ring) 10 being

inserted between the stack and each sleeve. The terminal sleeves 9 preferably consists also of special steel.

In order to cause a helical movement of the liquid flowing therethrough, a strip 7 of magnetizable rustproof metal which is wound to 1 to 2 helical windings is arranged in the inner tube 6, the width of the strip corresponding to the inner diameter of the inner tube 6. This strip is fixedly connected at both ends with the tubular connecting pieces, for example by welding to the inner wall thereof. The stack of ring magnets 3 which are all alike and spacer discs 4 is arranged as shown in fig. 2, so that beginning from the liquid inlet E, after a single spacer disc 4, a ring magnet 3 with its south pole at the inlet side, then is followed by two single spacer discs 4 and three ring magnets 3, each separated from the next by two spacer discs (4) and each with a polarization inverted from one to the next, and at last two twinned ring magnets 3a, 3b, again separated from the preceding ring magnet (3) and from each other by two spacer discs (4) and having a polarization which is inverted in respect to the preceding ring magnets and to the following twinned ring magnets, the single ring magnets 3a, 3b forming the twinned ring magnets contacting each other with opposite poles, so that at the outlet side of the stack there is a south pole, and the stack is terminated by a thicker spacer disc 4.

In the embodiment shown, the ring magnets have each an axial dimension of 9 mm and the spacer discs 4 an axial dimension of 3 mm, the last spacer disc at the outlet side having a thickness of 6 mm. Also in this example as shown, the inner tube 6 has a diameter of 0,5 inch (12,6 mm) and a length of 100 mm, and the helically wound strip is formed as a helix from a sheet of special steel of 0,5 mm thickness.

The helical windings of the wound strip lie within the inner tube 6, that is between the connecting pieces 5, and their number can be between 1 and 3, for example 2 as shown in fig. 1. The helically wound strip 7 extends into both connecting pieces 5 with each a diametrical opposed terminal part 8 without helical winding and is in this part provided with a recess 8a in order to facilitate fixation at the connecting part 5, for example by spot welding.

Optionally, the strip 7 can be formed without recess 8a at the inlet end thereof and can be provided with an inlet tip 14 which projects from the connecting piece 5 (fig. 3). This tip is directed against the direction of the flow and is rounded in front and at the edges 14a and preferably, at least at the edge, provided with smooth plastic coating. Instead, the inlet tip 12

can also be rounded with rounded edges 12a and preferably also be provided with a plastic coating (at least at the edge) (fig. 4). These smooth inlet tips avoid the attaching of fluff on the inlet edge of the metal strip 7. Optionally, the metal strip 7 can be coated with plastic material over all of its length.

If required, the flow section at the liquid outlet can be somewhat diminished by means of an insert 11 which is held at the end of the outlet connecting piece 5 in order to upwardly reduce the velocity of the liquid flow upwards of this end. In order to facilitate the installation of the permanent magnetic liquid treating device in a liquid conduct the connecting pieces 5 are provided at their end with an appropriate threading for connection to a pipe or provided with smooth ondulations for insertion in and fixation of connecting tubing.

Claims

1. A permanent magnetic liquid treating device (1) comprising a tubular housing (2) in which ring magnets (3) and magnetizable spacer discs (4) are located, coaxially to the longitudinal axis of the housing, and which has connecting pieces (5) at both ends, and comprising means causing a spiral motion of the liquid passing therethrough, and an inner tube (6) which is located in the housing, coaxially to the longitudinal axis thereof and at a distance from the inner wall of the housing, the ends of said inner tube being connected liquid-tightly to said connecting pieces, the liquid to be treated flowing through said inner tube, and the ring magnets (3) and spacer discs (4) being installed in the liquid-free space between the inner tube (6) and the tubular housing (2) in such a way that they lie one behind the other in the direction of the longitudinal axis of the housing, **characterized by** the following features:
 - a) the tubular housing (2) consists of a non-magnetizable material;
 - b) the inner tube (6) consists of a magnetizable rustproof metal;
 - c) the tubular connecting pieces (5) consisting of a magnetizable rustproof metal extend the inner tube (6) and form a single piece therewith;
 - d) the ring magnets (3) which are identical to each other are arranged in the ring space between the housing (2) and the inner tube (6) so that, beginning from the liquid inlet (E), there follow, after a single spacer disc (4), a ring magnet (3) with its south pole directed towards the inlet, then, each time after two single spacer discs (4), three ring magnets (3) with the polarity inverted from one to the next, and at last two twinned ring magnets (3a, 3b), again with polarity inverted in relation to the preceding ring magnet and to the following twinned ring magnet, the single ring magnets (3a, 3b) which constitute each twinned magnet contacting each other with opposite poles so that a south pole is at the outside of the stack, and a final thicker spacing disc (4).
 - e) the complete stack of ring magnets (3) and spacer discs (4) is held immovable and tightly enclosed in the housing (2) by means of sleeves (9) screwed upon the connecting pieces (5);
 - f) in the inner tube (6) there is fixedly held a strip (7) consisting of a magnetizable rustproof metal having a width corresponding to the inner diameter of the inner tube (6), said strip being wound to a helix with 1 to 3 turns;

- g) the metal strip (7) extends with each one of its end sections (8) into the connecting pieces (5), said end sections being without helix and diametrically opposed.
2. A permanent magnetic liquid treating device according to claim 1, **characterized in that** the housing (2) consists of aluminium or an aluminium alloy and that the inner tube (6), the connecting pieces (5) and the end sleeves which are screwed upon the threading of the connecting pieces consist of special steel.
 3. A permanent magnetic liquid treating device according to one of claims 1 or 2, **characterized in that** the axial dimension of each ring magnet (3) is 9 mm and that of the spacer discs (4) is 3 mm, and the last spacer disc (4) at the outlet side having a thickness of 6 mm.
 4. A permanent magnetic liquid treating device according to any of claims 1 to 3, **characterized in that** the inner tube (6) has a diameter of 0,5 inch (12,6 mm) and a length of 100 mm and that the helically wound strip (7) being prepared from a sheet of special steel of 0,5 mm thickness has 1 to 2 helix windings in the inner tube.
 5. A permanent magnetic liquid treating device according to any of the preceding claims, **characterized in that** an elastic sealing ring (10) surrounding the inner tube (6) is inserted between each of the outwardly last spacer discs (4) and the adjacent sleeve (9).
 6. A permanent magnetic liquid treating device according to any of claims 1 to 5, **characterized in that** the helically wound strip (7) is smooth or provided with projections which serve to create turbulence within the liquid flowing therethrough.
 7. A permanent magnetic liquid treating device according to any of the claims 1 to 6, **characterized in that** the helix-free diametrical terminal section (8) of the metal strip (7) at the inlet end extends outwardly from the connecting piece (5) and terminates in a tip (14) with rounded straight edges or in a rounded tip (12) with a rounded round edge (12a).
 8. A permanent magnetic liquid treating device according to any of claims 1 to 7, **characterized in that** at least the edges (14a, 12a) of the tips (14, 12) of the strip (7) have a coating of plastics material.

9. A permanent magnetic liquid treating device according to any of the claims 1 to 8, **characterized in that** both sides of the strip (7) are covered with a plastic coating.
10. A permanent magnetic liquid treating device according to any of the claims 1 to 9, **characterized in that** an insert (11) which reduces the flow section is arranged in the connecting piece (5) which is situated at the outlet side.
11. A permanent magnetic liquid treating device according to any of the claims 1 to 10, **characterized in that** the terminal outer part of the connecting pieces (5) is provided with a threading or smooth undulations for connection with a connecting pipe or tube, respectively.

Fig. 1

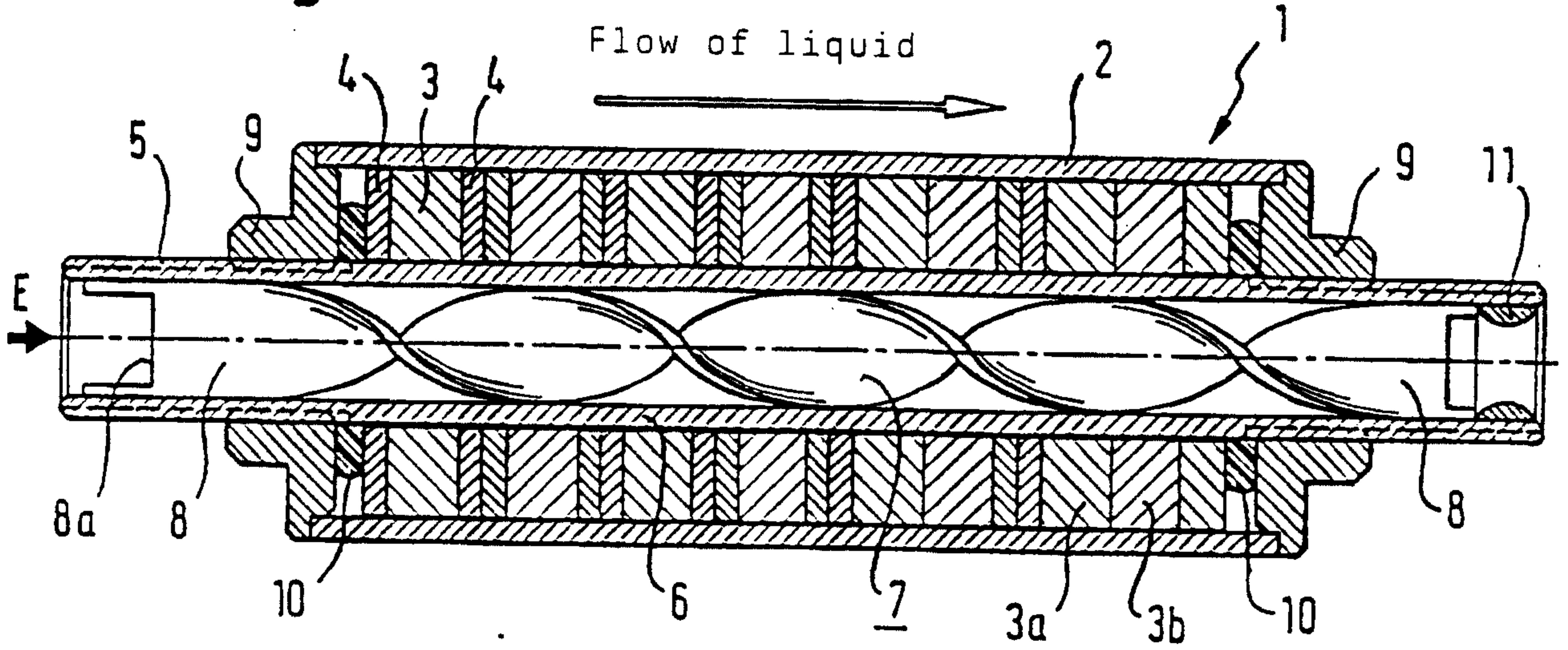

Fig. 2

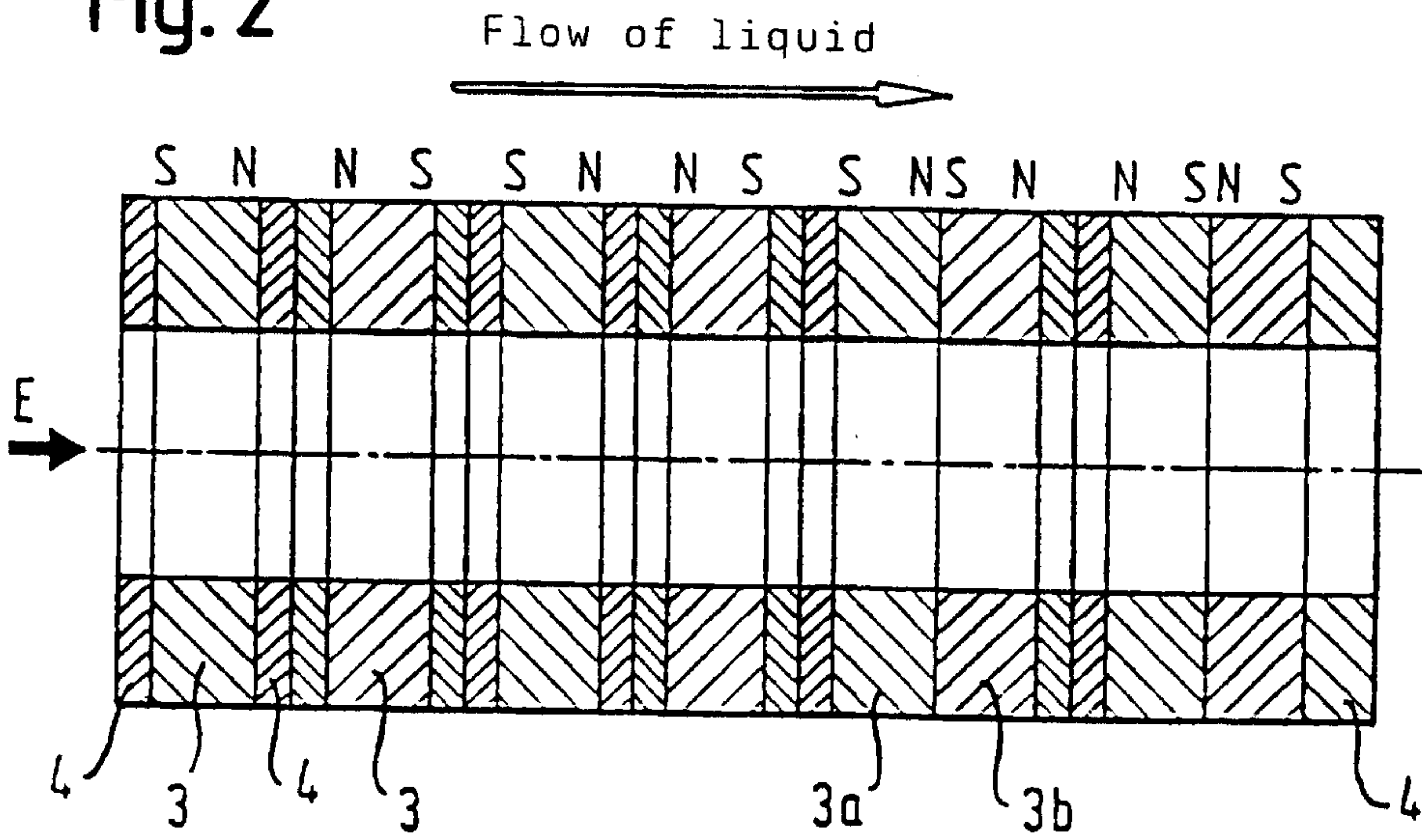

Fig. 3

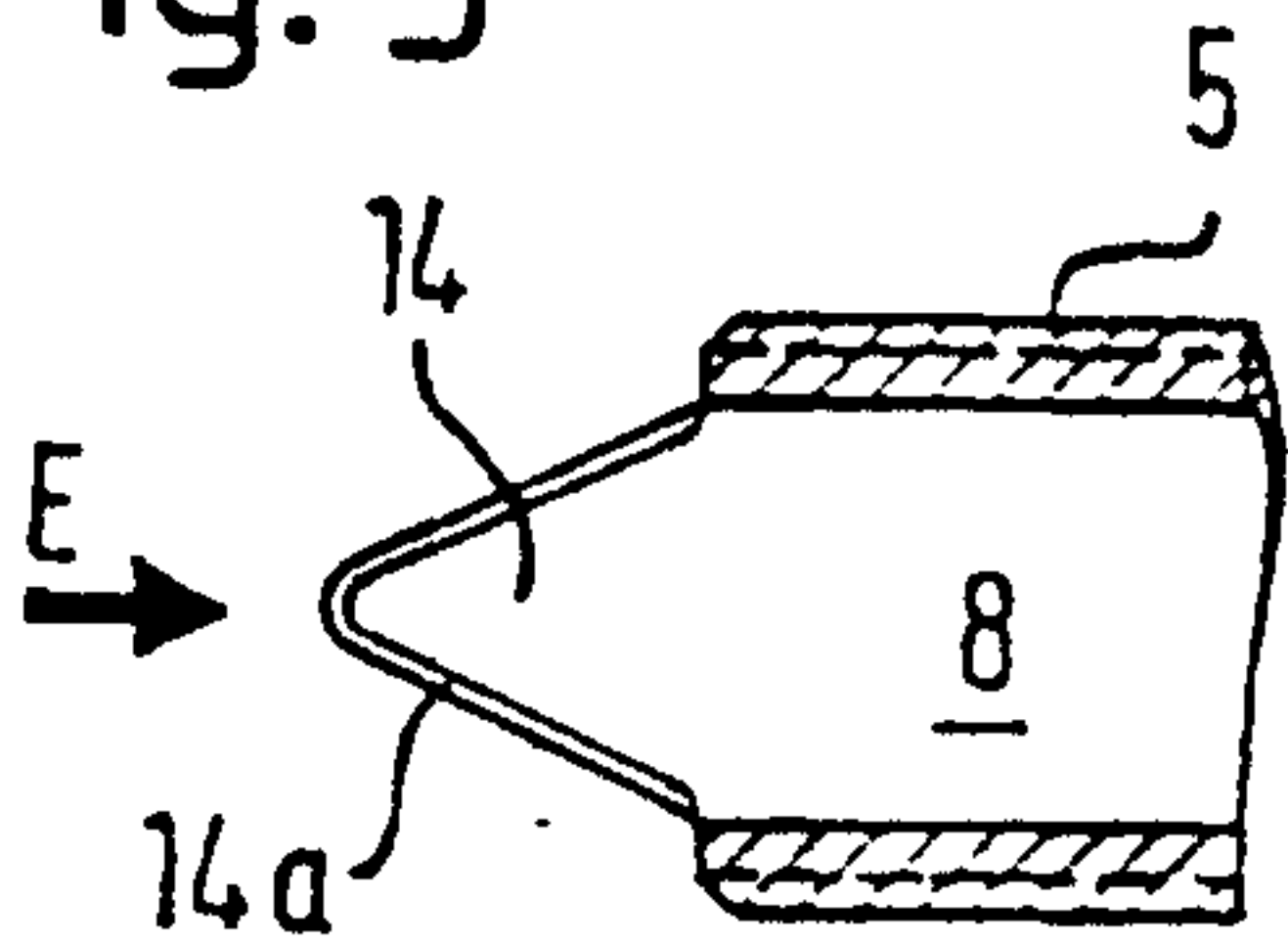

Fig. 4

