



(43) International Publication Date
5 January 2017 (05.01.2017)

- (51) International Patent Classification:
G06F 3/01 (2006.01)
- (21) International Application Number:
PCT/EP2016/062600
- (22) International Filing Date:
3 June 2016 (03.06.2016)
- (25) Filing Language: English
- (26) Publication Language: English
- (30) Priority Data:
15306024.9 29 June 2015 (29.06.2015) EP
- (71) Applicant: **ESSILOR INTERNATIONAL (COMPAGNIE GÉNÉRALE D'OPTIQUE)** [FR/FR]; 147, rue de Paris, 94220 Charenton-le-Pont (FR).
- (72) Inventors: **ROUSSEAU, Denis**; c/o Essilor International (Compagnie Générale d'Optique), 147, rue de Paris, 94227 Charenton-le-Pont Cedex (FR). **VILLETTE, Thierry**; c/o Essilor International (Compagnie Générale d'Optique), 147, rue de Paris, 94227 Charenton-le-Pont Cedex (FR).
- (74) Agents: **CABINET NOVITECH** et al.; 188, grande rue Charles de Gaulle, 94130 Nogent-sur-Marne (FR).

- (81) Designated States (unless otherwise indicated, for every kind of national protection available): AE, AG, AL, AM, AO, AT, AU, AZ, BA, BB, BG, BH, BN, BR, BW, BY, BZ, CA, CH, CL, CN, CO, CR, CU, CZ, DE, DK, DM, DO, DZ, EC, EE, EG, ES, FI, GB, GD, GE, GH, GM, GT, HN, HR, HU, ID, IL, IN, IR, IS, JP, KE, KG, KN, KP, KR, KZ, LA, LC, LK, LR, LS, LU, LY, MA, MD, ME, MG, MK, MN, MW, MX, MY, MZ, NA, NG, NI, NO, NZ, OM, PA, PE, PG, PH, PL, PT, QA, RO, RS, RU, RW, SA, SC, SD, SE, SG, SK, SL, SM, ST, SV, SY, TH, TJ, TM, TN, TR, TT, TZ, UA, UG, US, UZ, VC, VN, ZA, ZM, ZW.
- (84) Designated States (unless otherwise indicated, for every kind of regional protection available): ARIPO (BW, GH, GM, KE, LR, LS, MW, MZ, NA, RW, SD, SL, ST, SZ, TZ, UG, ZM, ZW), Eurasian (AM, AZ, BY, KG, KZ, RU, TJ, TM), European (AL, AT, BE, BG, CH, CY, CZ, DE, DK, EE, ES, FI, FR, GB, GR, HR, HU, IE, IS, IT, LT, LU, LV, MC, MK, MT, NL, NO, PL, PT, RO, RS, SE, SI, SK, SM, TR), OAPI (BF, BJ, CF, CG, CI, CM, GA, GN, GQ, GW, KM, ML, MR, NE, SN, TD, TG).

Published:

— with international search report (Art. 21(3))

(54) Title: A SCENE IMAGE ANALYSIS MODULE

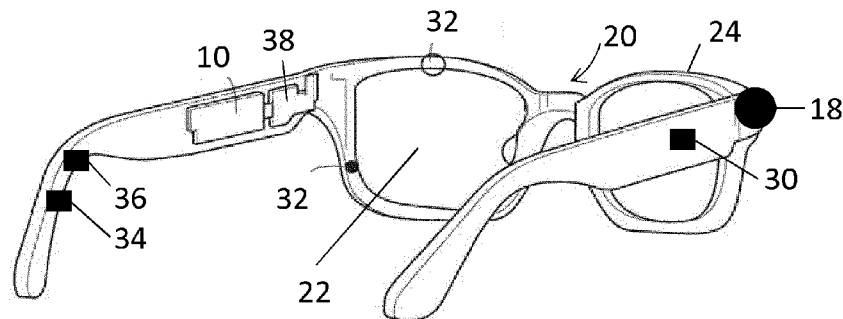

Figure 3

(57) Abstract: The invention relates to an analysis module (10) comprising: - a communication component (12) arranged to receive scene images from a scene camera (18) mounted on a head mounted device (20), the scene images corresponding to images of the environment facing the user of the head mounted device (20) when worn by the user, - an image analysis component (14) arranged to identify at least one predefined element from a list of predefined elements in a predefined analyzing zone (28) of the images received from the scene camera (18) and to analyze at least part of the scene images based on the identified at least one predefined element, and - a feedback component (16) arranged to generate feedback data and to send such data to the user of the head mounted device (20).

A scene image analysis module

FIELD OF THE INVENTION

5 The invention relates to an analysis module arranged to generate feedback to a user of a head mounted device based on the analysis of scene images.

 The invention further relates to a head mounted device comprising an analysis module according to the invention.

10 BACKGROUND OF THE INVENTION

 Usually, visually-impaired persons need a visual help and/or an audio help to better apprehend the real world.

 A head mounted device may fulfill such requirements.

15 However, actual head mounted devices are not optimized to analyze the environment facing the user of such head mounting device. Indeed, such devices comprise long computing times, extended response time to the user and manual confirmation. Moreover, such devices are not adapted to the user's viewing ability.

 Therefore, there is a need to provide a head-mounted device adapted to a user
20 and in particular adapted to automatically analyze scene images facing the user based on identified predefined elements according to the user's viewing ability.

SUMMARY OF THE INVENTION

25 To this end, the invention proposes an analysis module comprising:

- a communication component arranged to receive scene images from a scene camera mounted on a head mounted device, the scene images corresponding to images of the environment facing the user of the head mounted device when worn by the user,
- an image analysis component arranged to identify at least one predefined
30 element from a list of predefined elements in a predefined analyzing zone of the images received from the scene camera and to analyze at least part of the scene images based on the identified at least one predefined element, and

- a feedback component arranged to generate feedback data based on the analyze of at least part of the scene images and to send such data to the user of the head mounted device.

5 Advantageously, the analysis module according to the invention allows a relevant analysis of the environment facing the user of the head mounted device. Indeed, the image analysis component and the feedback component allows an automatic, fast and optimized analysis of the scene images facing the user of a head mounted device based on a predefined element according to the user's needs.

10

According to embodiments, the analysis module according to the invention may further comprise one or any possible combination of the following features:

- 15 - the communication component is arranged to receive scene images in real time, the image analysis component is arranged to identify at least one predefined element and analyze at least part of the scene images in real time and the feedback component is arranged to generate and send feedback data in real time; and/or
- 20 - the image analysis component is arranged to analyze at least part of the scene images upon identification of the at least one predefined element in the predefined analyzing zone over a predefined period of time; and/or
- 25 - the image analysis component is arranged to analyze at least part of the scene images upon confirmation from the user of the head mounted device; and/or
- the analysis module further comprises a head movement detection component arranged to detect head movement of the user of the head mounted device and wherein the image analysis component is arranged to analyze at least part of the scene images upon detection a stabilized head posture of the user; and/or
- 30 - the analysis module further comprises an eye tracking device arranged to track eye movements of the user of the head mounted device and wherein the image analysis component is arranged to analyze at least part of the scene images upon detection that the user is gazing in a direction corresponding to the predefined analyzing zone; and/or
- the predefined element comprises at least written characters and the analysis of the scene images comprises at least text recognition; and/or

- the predefined element comprises at least human face and the analysis of the scene images comprises at least face recognition; and/or
- the predefined element comprises at least traffic light and the analysis of the scene images comprises at least color recognition; and/or
- 5 - the predefined element comprises at least street sign and the analysis of the scene images comprises at least text and/or sign recognition; and/or
- the feedback component is arranged to provide a visual feedback to the user by applying an image processing on the scene images receive from scene camera of the head mounted device; and/or
- 10 - the feedback component is arranged to provide a visual feedback to the user by applying an image processing on the scene images receive from scene camera of the head mounted device; and/or
- the image processing is selected in the list comprising: magnifying, edge enhancing, color remapping, text recognition, pattern recognition, contrast enhancement and brightness enhancement; and/or
- 15 - the feedback component is arranged to provide an audio feedback to the user.

The invention also relates to a head mounted device comprising:

- a frame adapted to be worn on the head of a user,
- 20 - a scene camera fixed to the frame and adapted to acquire scene images of the environment facing the user when the head mounted device is being worn, and
- a communication unit arranged to send the scene images to an analysis module according to any of the preceding claims.

25

According to embodiments, the head mounted device according to the invention may further include one or any possible combination of the following features:

- the head mounted device further comprises an analysis module according to the invention,
- 30 - the head mounted device further comprises an output device arranged to output a signal to the user based on the feedback data sent by the feedback component,
- the output device is a display device and/or an audio output device.

Unless specifically stated otherwise, as apparent from the following discussions, it is appreciated that throughout the specification discussions utilizing terms such as "computing", "calculating", or the like, refer to the action and/or processes of a computer or computing system, or similar electronic computing device, that manipulate and/or transform data represented as physical, such as electronic, quantities within the computing system's registers and/or memories into other data similarly represented as physical quantities within the computing system's memories, registers or other such information storage, transmission or display devices.

Embodiments of the present invention may include apparatuses for performing the operations herein. This apparatus may be specially constructed for the desired purposes, or it may comprise a general purpose computer or Digital Signal Processor ("DSP") selectively activated or reconfigured by a computer program stored in the computer. Such a computer program may be stored in a computer readable storage medium, such as, but is not limited to, any type of disk including floppy disks, optical disks, CD-ROMs, magnetic-optical disks, read-only memories (ROMs), random access memories (RAMs) electrically programmable read-only memories (EPROMs), electrically erasable and programmable read only memories (EEPROMs), magnetic or optical cards, or any other type of media suitable for storing electronic instructions, and capable of being coupled to a computer system bus.

The processes and displays presented herein are not inherently related to any particular computer or other apparatus. Various general purpose systems may be used with programs in accordance with the teachings herein, or it may prove convenient to construct a more specialized apparatus to perform the desired method. The desired structure for a variety of these systems will appear from the description below.

In addition, embodiments of the present invention are not described with reference to any particular programming language. It will be appreciated that a variety of programming languages may be used to implement the teachings of the inventions as described herein.

BRIEF DESCRIPTION OF THE DRAWINGS

Other characteristics and advantages of the invention will become more apparent from the claims and from the following description of some embodiments given by way of example without limitation with reference to the drawings, in which:

- Figure 1 illustrates an embodiment of an analysis module according to the invention,
- Figure 2 represents a schematic scene image corresponding to an image of the environment facing the user of a head mounted device according to the invention when worn by the user,
- Figure 3 represents an embodiment of a head mounted device according to the invention,
- Figure 4 is a networked data-processing device according to the invention, and
- Figure 5 represents a schematic representation of a part of a head mounted device according to a further embodiment of the invention.

DETAILED DESCRIPTION OF PREFERRED EMBODIMENTS

Elements in the figures are illustrated for simplicity and clarity and have not necessarily been drawn to scale. For example, the dimensions of some of the elements in the figure may be exaggerated relative to other elements to help improve the understanding of the embodiments of the present invention.

Figure 1 illustrates an analysis module 10 according to the invention. The analysis module 10 comprises a communication component 12, an image analysis component 14 and a feedback component 16.

The communication component 12 is arranged to receive scene images from a scene camera 18 mounted on a head mounted device 20. The scene images correspond to images of the environment facing the user of the head mounted device 20 when worn by the user.

A scene image 26 is divided into at least two zones: a predefined analyzing zone 28 and a zone complementary to the predefined analyzing zone 28. For example, as illustrated in Figure 2, the predefined analyzing zone 28 corresponds to the right upper side of the scene image 26.

The predefined analyzing zone 28 is the same for all the scene images analyzed by the analysis module 10.

According to an embodiment of the invention, the predefined analyzing zone 28 may be the whole scene image.

In a preferred embodiment, the predefined analyzing zone 28 is a part of the scene image in order to reduce the computing time and to provide a quick response to the user of the head mounted device 20.

5 The predefined analyzing zone 28 may be adapted to the user of the head mounted device 20.

10 Moreover, the predefined analyzing zone 28 may be configured by the user of the head mounted device 20. For example, the configuration can be realized by communicating with the head mounted device 20 using a computer connected via Bluetooth. The user may indicate the predefined analyzing zone 28 with a computer mouse, or by entering coordinates, or with an eye tracking device for example. The size and the position of the predefined analyzing zone 28 may therefore be customized by the user of the head mounted device 20. During configuration, an external screen like a computer screen or a television can be used, or a display device mounted on the head mounted device 20. This display device can be removed after configuration, or not used
15 during standard system use, to save battery life and not perturbate standard vision. For example it can be active only when a predefined element has been detected in the predefined analyzing zone 28.

20 The image analysis component 14 is arranged to identify at least one predefined element from a list of predefined elements in the predefined analyzing zone 28 of the images received from the scene camera 18. The image analysis component 14 is further arranged to analyze at least part of the scene images based on the identified at least one predefined element.

25 In a preferred embodiment, the image analysis component 14 is arranged to analyze the predefined analyzing zone 28 of the scene images based on the identified at least one predefined element.

The predefined elements may be divided into different categories of predefined elements. For example, the categories of predefined elements may be written characters, human faces, traffic lights or street signs.

30 Each category of predefined elements may comprise different predefined sub-elements. For example, the street sign category may comprise a stop sign, a no entry sign, or a crosswalk sign. As a further example, the written character category may be a list of the usual words of a dictionary, or the human face category may comprise the faces of friends and/or acquaintances of the user of the head mounted device. The traffic

light category may, for example, comprise one predefined element, a tricolor traffic light.

For each predefined element may correspond an analysis, such as for example text recognition, face recognition, color recognition or sign recognition.

5 The predefined element may comprise at least written characters. For example, if the user is reading, he places the written characters in the predefined analyzing zone 28 and stops moving his head in order to analyze the scene images. In this case, the analysis of the scene images may comprise at least text recognition. The text recognition may comprise, for example, a detection and/or recognition of the words, spaces, uppercase, punctuation, color of the written characters...

10 The predefined element may further comprise at least human face. As an example, if the user seems to recognize an acquaintance, he places the human face in the predefined analyzing zone 28 and stops moving his head in order to analyze the scene images. In this case, the analysis of the scene images may further comprise at least face recognition. The face recognition may comprise a detection and/or recognition of the hair color, eyes color, form and edges of the face... in order to compare the results of the automatic face recognition with a predefined face database.

15 The predefined element may also comprise at least traffic light. Given by way of example, if the user is walking and wants to cross the street, he places the traffic light in the predefined analyzing zone 28 and stops moving his head. In this case, the analysis of the scene images may also comprise at least color recognition. The color recognition may comprise a detection and/or recognition of the green or red color, associated with brightness analysis.

20 The predefined element may further comprise at least street sign. In this case, the analysis of the scene images may further comprise at least text and/or sign recognition. The sign recognition may comprise a detection and/or recognition of the sign color, sign form, sign pattern... in order to compare the results of the automatic sign recognition with the list of predefined street sign.

25 In a preferred embodiment, the predefined element comprises at least written characters and human face and traffic light and street sign and the analysis of the scene images comprises at least text recognition and face recognition and color recognition and sign recognition.

30 The list of predefined elements is obviously not limited to the elements cited above and could comprise other elements.

The predefined element may be an element comprised in a database of elements and/or in a list of elements, or in any possible index of elements.

In a preferred embodiment, the predefined element is comprised in a list of predefined elements.

5 If the list of predefined elements comprises only one predefined element, the image analysis component 14 may be arranged to identify the predefined element in the predefined analyzing zone 28 of the images received from the scene camera 18. For example, an analysis module 10 may be configured to analyze only written characters, and thus, the user of the head mounted device might use it only when he would like to
10 read.

The list of predefined elements may be stored in a memory comprised in the image analysis component 14 and/or in a distant entity, such a smartphone, a touch pad, a computer or the Internet.

15 In a preferred embodiment, the list of predefined elements is stored in the image analysis component 14.

Moreover, when the list of predefined elements is not stored in the analysis module 10, the communication component may also be arranged to access to the list of predetermined elements.

20 The list of predefined elements may also be given and/or completed by the user of the head mounted device 20.

Advantageously, the image analysis component 14 may be arranged to analyze at least part of the scene images upon identification of the at least one predefined element in the predefined analyzing zone 28 over a predefined period of time.

25 The predefined period of time is defined as the time a user should maintain the predefined element in the predefined analyzing zone 28 or in any predefined zone without moving his head in order to have the image analysis component 14 to start the analysis of the scene images.

The predefined period of time may be of 2 or 3 seconds. Advantageously, the predefined period of time is greater than or equal to one second.

30 According to an embodiment of the invention, the image analysis component 14 may be arranged to analyze the whole scene images upon identification of the at least one predefined element in the predefined analyzing zone over the predefined period of time. For example, if the user places the predefined element at the limit of the predefined analyzing zone 28, or if the predefined element exceeds the predefined

analyzing zone 28, the image analysis component 14 may analyze the whole scene images.

In a preferred embodiment, the image analysis component 14 is arranged to analyze the predefined analyzing zone of the scene images upon identification of the at least one predefined element in the predefined analyzing zone over the predefined period of time in order to reduce the computing time and to provide quick response to the user of the head mounted device.

The image analysis component may further be arranged to analyze at least part of the scene images upon confirmation from the user of the head mounted device.

The confirmation from the user of the head mounted device 20 may be a vocal confirmation. The vocal confirmation may be a word said by the user of the head mounted device 20. The head mounted device 20 may comprise, for example, a vocal recognition sensor 30. The vocal recognition sensor 30 may be located on the frame 24 of the head mounted device 20, as illustrated on Figure 3.

The confirmation from the user of the head mounted device may further be a manual confirmation. The manual confirmation may be a press from the user of the head mounted device 20 on a button (not shown) placed on the frame 24 of the device.

The confirmation from the user of the head mounted device may also be a visual confirmation. The visual confirmation may be detected by an eye tracking device 32. As an example, an eye tracking device 32 is illustrated on Figure 3. For example, after the display of a virtual confirmation button to the user of the head mounted device, the eye tracking device track eyes movements of the user upon detection that the user is gazing in the direction corresponding to the virtual confirmation button. The virtual confirmation button may be displayed on a display device mounted on the head mounted device 20. The visual confirmation may also be a prolonged eye's blink.

Moreover, the image analysis component 14 may be arranged to analyze the whole scene images upon confirmation from the user of the head mounted device 20.

In a preferred embodiment, the image analysis component 14 is arranged to analyze the predefined analyzing zone 28 of the scene images upon confirmation from the user of the head mounted device 20.

The analysis module 10 may further comprise a head movement detection component 34 arranged to detect head movement of the user of the head mounted device 20. The image analysis component 14 may be arranged to analyze at least part of the scene images upon detection a stabilized head posture of the user.

In another words, when the user of the head mounted device 20 wants to analyze of the scene images, he places the predefined element in the predefined analyzing zone 28 and stops moving its head. The head movement detection component 34 detects that a stabilized head posture of the user and send a signal to the analysis component 10
5 which analyzes at least part of the scene images.

The head movement detection component 34 can comprise an accelerometer and/or gyroscope and/or compass configured to sense the orientation and position and variation of orientation and position of the module.

The head movement detection component 34 may be placed on the frame 24 of
10 the head mounted device 20, as illustrated on Figure 3.

The analysis module 10 may further comprise an eye tracking device 32 arranged to track eye movements of the user of the head mounted device 20. The image analysis component 14 is arranged to analyze at least part of the scene images upon detection that the user is gazing in a direction corresponding to the predefined analyzing
15 zone 28.

In another words, when the user of the head mounted device 20 wants an analysis of the scene images, he places the predefined element in the predefined analyzing zone 28 and gazes on the direction of the predefined analyzing zone 28 or in any another predetermined zone.

If there is no eye tracking device, only the head positioning can be used to select
20 the predefined zone. In this case the user just needs to verify that in the display device mounted on the head mounted device, the predefined element is placed at the right place. If there is no eye tracking device and no display device, the user must remember the location of the predefined analyzing zone 28 to place the predefined element into.
25 For example, if he wears standard glasses, a small marking on the glasses can help to indicate the predefined analyzing zone 28, like color change or contour indication of the zone. In this case the glasses must be positioned correctly on user's head, just like during the predefined analyzing zone configuration stage.

With an eye tracking device, there is not necessarily a display device on the head
30 mounted device.

The eye tracking device 32 detects that the user is gazing in a direction corresponding to the predefined analyzing zone 28 or corresponding to any another predetermined zone. Then the eye tracking device 32 sends a signal to the analysis component 10 to analyze at least part of the scene images.

Moreover, the eye tracking device 32 can send a signal to the analysis component 10 when the user places the predefined element in the predefined analyzing zone 28 and gazes in the direction corresponding to the predefined analyzing zone 28 without moving his head during at least a predefined period of time. The predefined
5 period of time may be more than one second. For example, the predefined period of time may be 2 or 3 seconds.

The eye tracking device 32 may also be combined with mirrors and/or prisms in order to obtain an optical path for the eye tracking orthogonal to the pupil of the user.

Moreover, the eye tracking information may be averaged and dampened in order
10 to minimize the sensitivity to random eye movements and/or blinks.

The head mounted device may also comprise one eye tracking device 32 for each eye of the user.

The feedback component 16 is arranged to generate feedback data based on the analysis of at least part of the scene images and to send such data to the user of the head
15 mounted device 20.

The feedback component may be arranged to provide a visual feedback to the user by applying an image processing on the scene images received from scene camera 18 of the head mounted device 20.

The image processing may preferably be selected in the list comprising:
20 magnifying, edge enhancing, color remapping, text recognition, pattern recognition, contrast enhancement and brightness enhancement.

In another words, the visual feedback provided to the user can be an image of the scene images customized according to the visual behavior of the user. For example, for a color-blinded user, the improved image can be an image with color remapping, or
25 for a short-sighted user, the improved image can be a zoom on the predefined analyzing zone 24 of the scene images.

The visual feedback data can also be a text. For example, for a short-sighted user, if the user is walking and wants an analysis of a street sign, the visual feedback can be a zoom on the text written on the street sign.

The visual feedback may be provided on a display device mounted on the head
30 mounted device 20.

The head mounted device 20 may also comprise one display device for each eye of the user. In this case, the visual feedback may be provided to the user on the two display devices of the head mounted device.

In a preferred embodiment, the visual feedback is provided to the user in the predefined analyzing zone 28.

The visual feedback can be done on the full display for zoom operation, or other processing that can improve feedback effect, like text display with more readable fonts and/or colors.

The feedback component may further be arranged to provide an audio feedback to the user.

For example, if the user is reading a book, the audio feedback can be an audio sound corresponding to the book. Moreover, for a color-blinded user, if the user is looking at traffic lights, the audio feedback can be a sentence such as “the light is green” or “the light is red”.

The audio feedback can be provided through an earphone, a speaker, a headset or any possible audio output device. Advantageously, the audio output device 36 is located on the frame 24 of the head mounted device 20, as illustrated on Figure 3. The audio output device 36 may also be located in the ear of the user.

In a preferred embodiment, the audio output device 36 is located the closest possible to the user’s ear.

The feedback data may also depends on the predefined element and on the user. Indeed, for example, a color-blinded user may prefer an audio feedback rather than a visual when the predefined element is a traffic light. As a further example, a user which is reading may prefer a visual feedback, such as a zoom on the scene image, rather than an audio feedback.

A simple LED feedback can also be done with LED elements (not shown) positioned on the frame, for example on both sides for color-blind user, or a single multi-color LED for other users.

Moreover, the feedback component 16 can be arranged to generate feedback data based on the analysis of the whole scene images and to send such data to the user of the head mounted device 20.

In a preferred embodiment, the feedback component 16 is arranged to generate feedback data based on the analysis of the predefined analyzing zone 28 of the scene images and to send such data to the user of the head mounted device 20.

Furthermore, the communication component 12 may be arranged to receive scene images in real time, the image analysis component 14 may be arranged to identify at least one predefined element and analyze at least part of the scene images in real time

and the feedback component 16 may be arranged to generate and send feedback data in real time.

In the sense of the invention, the “real time” is when the time between the scene images reception by the communication component 12 of the analysis module 10 and the feedback generation by the feedback component 16 of the analysis module 10 is less than one second, for example less than 200ms.

Advantageously, a 4 time ratio between the predefined period of time and the real time provides good results. For example the predefined period of time during which the user should gaze the analyzing zone 28 may be 2 seconds and the time during which the analysis module may receive and analyze the image scene and generate feedback data may be 500ms.

A head mounted device according to an embodiment of the invention will now be described.

Figure 3 represents an example of a head mounted device 20 according to the invention. The head mounted device comprises a frame 34 adapted to be worn on the head of a user, a scene camera 18 fixed to the frame 24 and a communication unit 38.

The head mounted device 20 represented on Figure 3 also comprises two lenses 22, vocal recognition sensor 30, an eye tracking device 32, a head movement detection component 34 and an audio output device 36, directed at the left side of the wearer’s head (not shown).

The scene camera 18 is adapted to acquire scene images of the environment facing the user when the head mounted device 20 is being worn.

Advantageously, the scene camera 18 is located on the frame 24 of the head mounted device 20. More precisely, the scene camera 18 may be located between the eyes of the user or may be located on a side of the head mounted device 20, in order to acquire scene images corresponding to the environment seen by one eye of a user. For example, if the scene camera is located on the right side of the frame 24, the environment corresponding to the scene images seen by the right eye of the user are acquired.

The scene camera 18 may comprise a charged coupled device (CCD) image sensor, a complementary metal oxide semiconductor (CMOS) image sensor, or in any other image sensor with an analog or digital signal output that can be sent to the communication component 12.

The head mounted device may also comprise one scene camera for each eye of the user. In this case, each scene camera may be located on a side of the frame in order to acquire scene images seen by both eyes of the user of the head mounted device.

5 The lenses 22 of the head mounted device may be spectacle lenses or spectacle glasses. The lenses 22 may correspond to the optical prescription of the user.

The lenses 22 may also be active lenses with an optical function which can be adapted to the user's needs.

10 The head mounted device 20 may also comprise a display device 40. An example of display device 40 is represented on Figure 5. The display device allows the wearer to see both virtual images and/or texts and the real world through it. The display device 40 can be divided into two zones, a zone for the virtual image and/or text and a zone for the real world.

15 The display device 40 is able to display images and/or texts. An electronic driving system (memory + processor, not shown) sends to the display device 40 the image and/or text to display. Preferably it is able to display image and/or text in different viewing directions.

By way of example, the display device 40 may be a liquid crystal display, or use liquid crystal on silicon technology or organic light emitting diode technology, associated with a light guide, that can be transparent or semi-transparent.

20 The communication unit 38 is arranged to send the scene images to an analysis module 10 according to the invention. The communication unit 38 will be described more precisely latter in the description.

The head mounted device 20 may further comprise an analysis module 10 according to the invention, as illustrated on Figure 3.

25 The head mounted device 20 may comprise an output device arranged to output a signal to the user based on the feedback data sent by the feedback component 16.

The output device may be a display device and/or an audio output device. As represented on Figure 3, the head mounted device comprises a display device 40 and an audio output device 36.

30 Although not represented, the head mounted device 20 may further comprise a power source, for example a battery and/or other electronics.

In a preferred embodiment, the components and/or devices of the head mounted device 20 are arranged so that the weight of the head mounted device 20 may be substantially equal on each side of the frame 24. For example, all the components

and/or devices of the head mounted device 20 can be in the left side of the frame 24 when the power source is located on the right side of the frame 24.

5 According to an embodiment of the invention, illustrated on Figure 4, the head mounted device 20 communicates with a distant entity that comprises an analysis module 10.

Communication can be done through different communication devices and protocols, like Bluetooth, Zigbee, WiFi or others.

10 For example, the communication unit 38 may be configured to communicate with the distance entity either to store the analysis of at least part of the scene images in a memory MEM or to provide a feedback data based on the analysis of the at least part of the scene images corresponding to images of the environment facing the user of the head mounted device 20.

15 Typically, the distance entity comprises a communication unit COM configured to communicate at least with the head mounted device 20, a memory MEM, at least one processor PROC and program instructions stored on a non-transitory computer-readable medium and executable by the at least one processor to generate a feedback data based on the analysis of the at least part of the scene images corresponding to images of the environment facing the user of the head mounted device 20.

20 The distance entity can include different computing objects such as personal digital assistants, audio/video devices, mobile phones, MPEG-1 Audio Layer 3 (MP3) players, personal computers, laptops, tablets, Bluetooth headset, watch, wristband, etc...

25 In a network environment in which the communications network/bus can be the Internet, the computing objects can be Web servers, file servers, media servers, etc. with which the client computing objects or devices communicate via any of a number of known protocols, such as the hypertext transfer protocol (HTTP).

30 The invention has been described above with the aid of embodiments without limitation of the general inventive concept. Moreover, the embodiments of the invention may be combined without any restriction.

Many further modifications and variations will suggest themselves to those skilled in the art upon making reference to the foregoing illustrative embodiments, which are given by way of example only and which are not intended to limit the scope of the invention, that being determined solely by the appended claims.

In the claims, the word “comprising” does not exclude other elements or steps, and the indefinite article “a” or “an” does not exclude a plurality. The mere fact that different features are recited in mutually different dependent claims does not indicate that a combination of these features cannot be advantageously used. Any reference signs
5 in the claims should not be construed as limiting the scope of the invention.

CLAIMS

1. An analysis module (10) comprising:

5 - a communication component (12) arranged to receive scene images from a scene camera (18) mounted on a head mounted device (20), the scene images corresponding to images of the environment facing the user of the head mounted device (20) when worn by the user,

10 - an image analysis component (14) arranged to identify at least one predefined element from a list of predefined elements in a predefined analyzing zone (28) of the images received from the scene camera (18) and to analyze at least part of the scene images based on the identified at least one predefined element, and

15 - a feedback component (16) arranged to generate feedback data based on the analyze of at least part of the scene images and to send such data to the user of the head mounted device (20).

2. The analysis module (10) according to claim 1, wherein the communication component (12) is arranged to receive scene images in real time, the image analysis component (14) is arranged to identify at least one predefined element and analyze at least part of the scene images in real time and the feedback component (16) is arranged to generate and send feedback data in real time.

3. The analysis module (10) according to claim 1 or 2, wherein the image analysis component (14) is arranged to analyze at least part of the scene images upon identification of the at least one predefined element in the predefined analyzing zone (28) over a predefined period of time.

4. The analysis module (10) according to any of the preceding claims, wherein the image analysis component (14) is arranged to analyze at least part of the scene images upon confirmation from the user of the head mounted device (20).

5. The analysis module (10) according to any of the preceding claims, further comprising a head movement detection component (34) arranged to detect head movement of the user of the head mounted device (20) and wherein the image analysis

component (14) is arranged to analyze at least part of the scene images upon detection a stabilized head posture of the user.

5 6. The analysis module (10) according to any of the preceding claims, further comprising an eye tracking device (32) arranged to track eye movements of the user of the head mounted device (20) and wherein the image analysis component (14) is arranged to analyze at least part of the scene images upon detection that the user is gazing in a direction corresponding to the predefined analyzing zone (28).

10 7. The analysis module (10) according to any of the preceding claims, wherein the predefined element comprises at least written characters and the analysis of the scene images comprises at least text recognition.

15 8. The analysis module (10) according to any of the preceding claims, wherein the predefined element comprises at least human face and the analysis of the scene images comprises at least face recognition.

20 9. The analysis module (10) according to any of the preceding claims, wherein the predefined element comprises at least traffic light and the analysis of the scene images comprises at least color recognition.

25 10. The analysis module (10) according to any of the preceding claims, wherein the predefined element comprises at least street sign and the analysis of the scene images comprises at least text and/or sign recognition.

30 11. The analysis module (10) according to any of the preceding claims, wherein the feedback component (16) is arranged to provide a visual feedback to the user by applying an image processing on the scene images receive from scene camera (18) of the head mounted device (20).

12. The analysis module (10) according to the preceding claim, wherein the image processing is selected in the list comprising: magnifying, edge enhancing, color remapping, text recognition, pattern recognition, contrast enhancement and brightness enhancement.

13. The analysis module (10) according to any of the preceding claims, wherein the feedback component (16) is arranged to provide an audio feedback to the user.

5 14. A head mounted device (20) comprising:

- a frame (24) adapted to be worn on the head of a user,
- a scene camera (18) fixed to the frame (24) and adapted to acquire scene images of the environment facing the user when the head mounted device (20) is being worn, and
- 10 - a communication unit (38) arranged to send the scene images to an analysis module (10) according to any of the preceding claims.

15 15. The head mounted device (20) according to claim 14, further comprising an analysis module (10) according to any of claims 1 to 13.

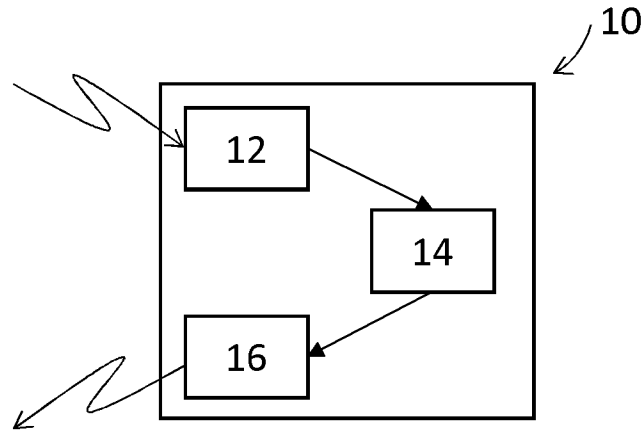

Figure 1

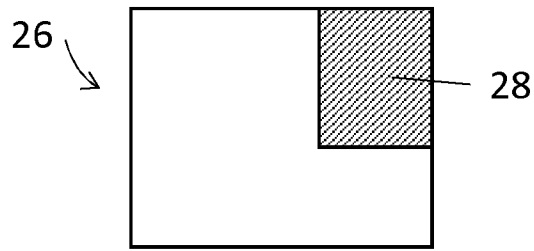

Figure 2

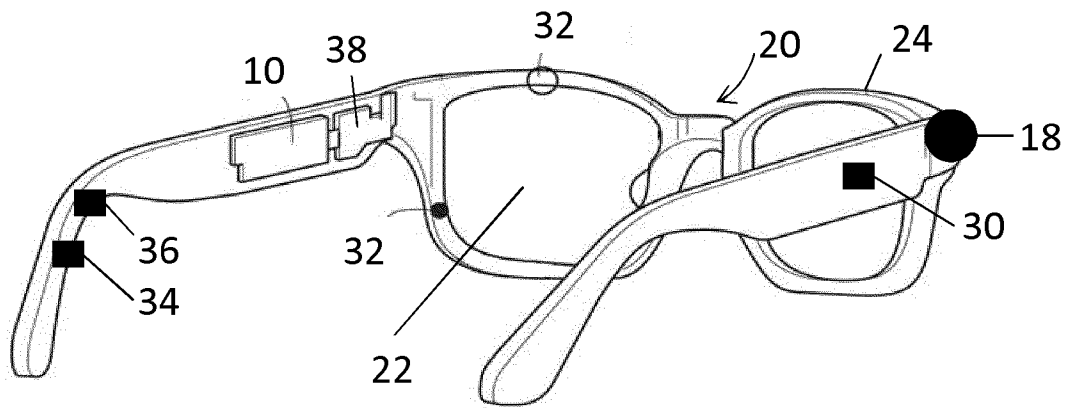

Figure 3

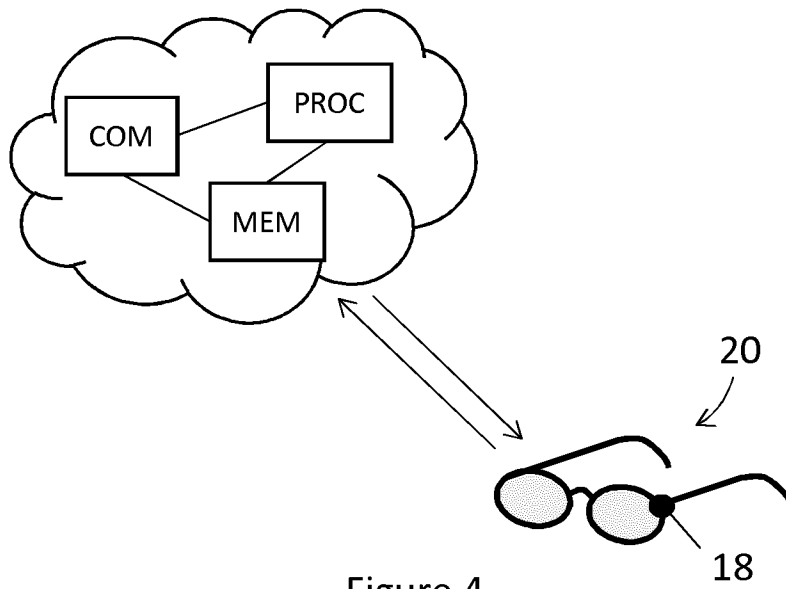

Figure 4

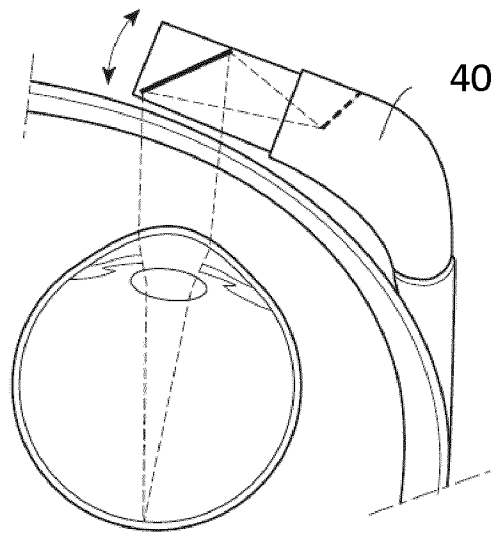

Figure 5

INTERNATIONAL SEARCH REPORT

International application No
PCT/EP2016/062600

A. CLASSIFICATION OF SUBJECT MATTER
INV. G06F3/01
ADD.

According to International Patent Classification (IPC) or to both national classification and IPC

B. FIELDS SEARCHED
Minimum documentation searched (classification system followed by classification symbols)
G06F

Documentation searched other than minimum documentation to the extent that such documents are included in the fields searched

Electronic data base consulted during the international search (name of data base and, where practicable, search terms used)
EPO-Internal, WPI Data, INSPEC, COMPENDEX, IBM-TDB

C. DOCUMENTS CONSIDERED TO BE RELEVANT

Category*	Citation of document, with indication, where appropriate, of the relevant passages	Relevant to claim No.
X	US 2012/075168 A1 (OSTERHOUT RALPH F [US] ET AL) 29 March 2012 (2012-03-29) paragraphs [0183], [0199], [0276], [0331] - [0333], [0335], [0338], [0339], [0343], [0357], [0379], [0384] - paragraphs [0385], [0395] - [0397] -----	1-15

Further documents are listed in the continuation of Box C.

See patent family annex.

* Special categories of cited documents :

- "A" document defining the general state of the art which is not considered to be of particular relevance
- "E" earlier application or patent but published on or after the international filing date
- "L" document which may throw doubts on priority claim(s) or which is cited to establish the publication date of another citation or other special reason (as specified)
- "O" document referring to an oral disclosure, use, exhibition or other means
- "P" document published prior to the international filing date but later than the priority date claimed

- "T" later document published after the international filing date or priority date and not in conflict with the application but cited to understand the principle or theory underlying the invention
- "X" document of particular relevance; the claimed invention cannot be considered novel or cannot be considered to involve an inventive step when the document is taken alone
- "Y" document of particular relevance; the claimed invention cannot be considered to involve an inventive step when the document is combined with one or more other such documents, such combination being obvious to a person skilled in the art
- "&" document member of the same patent family

Date of the actual completion of the international search 8 July 2016	Date of mailing of the international search report 19/07/2016
------------------------------------------------------------------------------	----------------------------------------------------------------------

Name and mailing address of the ISA/ European Patent Office, P.B. 5818 Patentlaan 2 NL - 2280 HV Rijswijk Tel. (+31-70) 340-2040, Fax: (+31-70) 340-3016	Authorized officer Wiedmeyer, Vera
----------------------------------------------------------------------------------------------------------------------------------------------------------------------	-------------------------------------------

INTERNATIONAL SEARCH REPORT

Information on patent family members

International application No

PCT/EP2016/062600

Patent document cited in search report	Publication date	Patent family member(s)	Publication date
US 2012075168	A1	NONE	