

[72] Inventor **Karl Schindlauer**
11, Ferdinand-Buchbergergasse, A-2340
Modling, Austria

[21] Appl. No. **777,699**

[22] Filed **Nov. 21, 1968**

[45] Patented **Apr. 13, 1971**

[32] Priority **Dec. 20, 1967**

[33] **Austria**

[31] **A11493/67**

[56] **References Cited**

UNITED STATES PATENTS			
2,653,656	9/1953	Kuebler.....	16/95UX
3,297,075	1/1967	Howell et al.....	160/19
FOREIGN PATENTS			
1,467,343	12/1966	France	16/95
402,347	11/1933	Great Britain.....	160/19
714,537	9/1954	Great Britain.....	16/87.4
184,833	9/1936	Switzerland	16/95
202,810	5/1939	Switzerland	16/95

Primary Examiner—Donald A. Griffin
Attorney—Eugene M. Eckelman

[54] **CURTAIN HOLDER**
4 Claims, 5 Drawing Figs.

[52] U.S. Cl..... **16/95,**
160/19

[51] Int. Cl..... **A47h 1/04**

[50] Field of Search..... **16/95, 87.4;**
160/19, 345

ABSTRACT: The invention includes a curtain holder having running slots for gliders. The holder incorporates a face panel for hiding the upper portion of the curtains and gliders. This face panel is removably attached to the holder by a snap-joint fit. The face panel can also be applied to the ends of the holder, and friction insert means are used to assist in attaching the ends of the face panel to the holder.

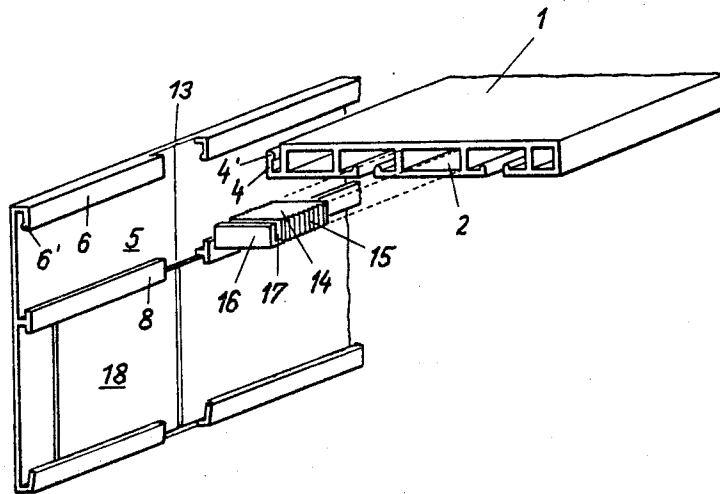

Patented April 13, 1971

3,574,887

2 Sheets-Sheet 1

FIG. 1

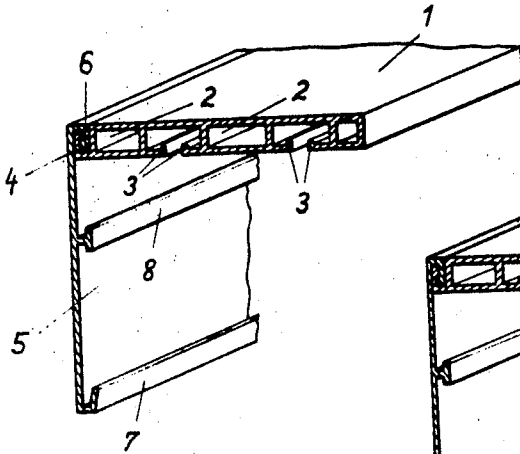

FIG. 2

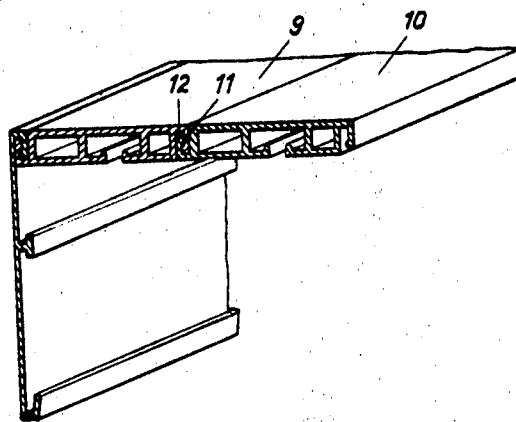
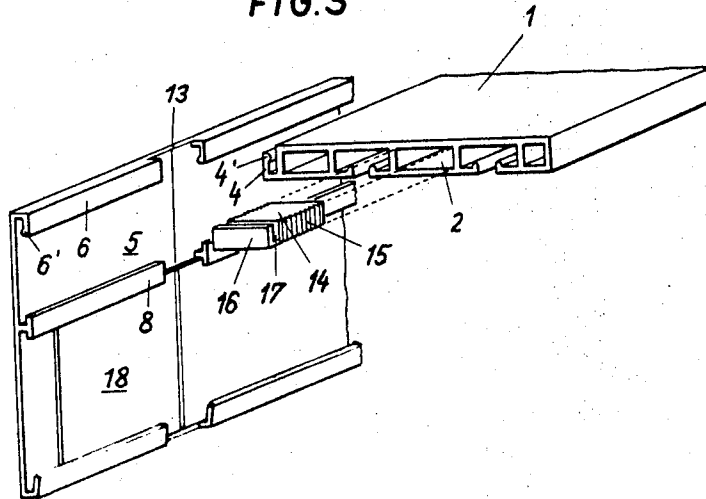

FIG. 3



INVENTOR
KARL SCHINDLAUER
By *Eugene M. Eckelman*
ATTORNEY

FIG. 4

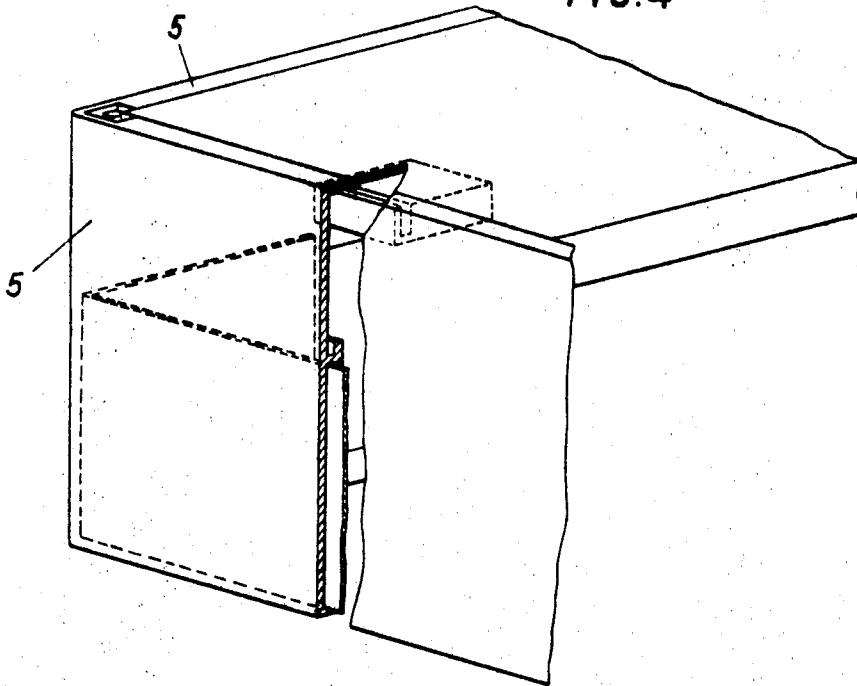
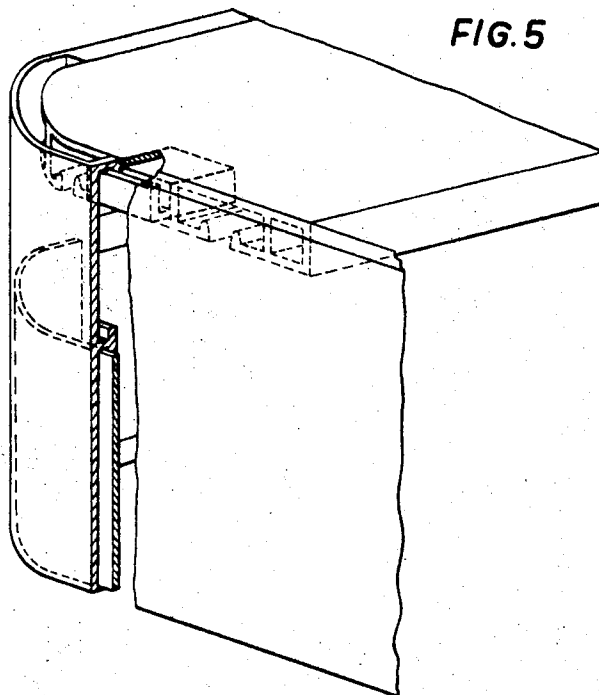

FIG. 5



INVENTOR
KARL SCHINDLAUER
By *Eugene M. Eckelman*
ATTORNEY

CURTAIN HOLDER

Various types of holders for curtains are known which have one or several running slots. These holders may be made of plastic in the shape of box profiles and are attached to the ceiling or the wall of a room by means of projecting brackets. In order to accomplish an appealing appearance, these curtain holders have to be concealed with face plates so that the supporting and gliding provisions are invisible from the inside of the room.

Until now such face means consisted either of wood moldings or metal rails, which likewise were fastened to the ceiling or to be brackets for the curtain holding provisions; thereby the expense for material and installation was considerable so that the costs for the face means were often higher than the curtain holders themselves.

The invention before us has the aim to avoid these disadvantages and has as its goal the creation of a simple and at the same time pleasing face plate, which can be connected by means of a simple push connection to the curtain holder, which also can be adapted to the various lengths of the curtain holder, according to the expense of the room; and which enables it furthermore to provide it with bent end parts, so that the curtain holder is covered not only towards the inside of the room but also at both its ends.

According to the invention, the face plate is recognizable in such a manner that its upper edge is bent downward like a hook and preferably thickened like a pad, whereby the hooklike part can be inserted by snap closure into a groove which extends upward from the border ledge of the curtain holder.

In order to obtain increased stiffness of the face plate, also, its lower edge is bent inward like a hook in an upward direction. The thought to increase the stiffness of the face plate led also to a T-like reinforcing rib along its full length. Face plates which have a hooklike edge bent in at the upper and lower rim, can also be made of a thinner material if they have such a T-like reinforcing rib and they have yet the same strength, especially torsion resistance, as wooden moldings, etc. By providing cutouts at predetermined locations of the bent-in edges and the reinforcing rib, the face plates can be bent round or at a 90° angle and then form the side limits for the ends of the curtain holder.

In a preferred form of the invention the face plate has an upper hooklike rim which is adapted to be inserted by friction closure in a void which runs longitudinally of the curtain holding portion. Connectors are used for holding the end portions of the face plates securely on the holder, and to better serve this purpose the connector can have ribbed surfaces.

The subject of the invention is illustrated as follows:

FIGS. 1 and 2 are perspective views of curtain holders with face plates attached thereto;

FIG. 3 is a perspective view of a corner closure for the curtain holder; and

FIGS. 4 and 5 are perspective views of two modifications of such corner closures.

In the illustrations, 1 signifies the curtain holder, which consists of a void 2 in a boxlike plastic profile. Running rails 3 are provided on the bottom part of the holder, which have slots for the guidance of the gliders. The curtain holder has on the side facing the room a projecting ledge 4, so that a groove is formed throughout the length of the holder. The projecting ledge 4 is thickened in a padlike structure at its upper end, as

designated by 4'. The face plate is designated by the numeral 5; its upper rim 6 is bent downwards in a hooklike fashion and thickened at the end in a padlike structure, as designated by the numeral 6'. Therefore, the hooklike part 6 can be inserted by a toothlike snap closure into the groove formed by the protruding ledge 4 and the accomplishes a simple and secure connection. In the examples shown in the drawings, the lower edge 7 of the face plate 5 is bent inward in a hook shape; further, the face plate has a reinforcing rib 8 assuming a T-shape running its entire length. In this manner a sufficient stiffness is obtained, especially torsional stiffness. FIG. 2 shows a changed form of the curtain holder, whereby the curtain holder is formed of two narrower parts 9 and 10 which are connected with push connection by toothlike interlocking edges 11 and 12. FIG. 3 shows the making of an end closure, whereby the face plate is bent 90° over a side end of the curtain holder. In order to accomplish this connection, a piece is cut out at the intended spot of bending 13, as well as the hooklike upper rim 6 and the hooklike lower rim 7 of the face plate; likewise the reinforcing rib 8 is cut out at that spot. Now the face plate can be bent along line 13 at a right angle. The connection of the side part of the face plate which was formed after bending the face plate is accomplished by means of an intermediate piece 14 which is dimensioned in such a manner that it can be inserted by friction closure in a boxlike void 2 of the curtain holder. In order to obtain a good snap closure, the surfaces of the intermediate piece are formed with ribs, as illustrated at 15. Furthermore, the intermediate piece has a projecting ledge 16 which reaches up into the boxlike void 2 after insertion of the intermediate piece 14, whereupon the hooklike part 6 of the side part of the face plate can be inserted in the groove 17, after having been bent at a right angle.

According to the form illustrated in FIG. 3, it is also possible to insert a metal leaf 18 between the reinforcing rib 8 and the lower hooklike part 7, which will be bent along with the plate 5 when bending, whereby the corner connection obtains a greater strength.

FIGS. 4 and 5 show corner closures, made according to the method shown in FIG. 3, whereby the face plate in FIG. 4 is bent at a right angle and in FIG. 5 is bent round.

I claim:

1. A curtain holder comprising a body portion, means in said body portion arranged to slidably support depending curtain-holding slides, a face plate, means in said body portion defining a groove, an upper hooklike, inwardly bent portion on said face plate arranged to have snap engagement in said groove for detachably connecting said face plate to said body portion, means at one end of said body portion forming a socket, and an insert frictionally engageable in said socket and having a downwardly extending groove on one end thereof, said groove being arranged to be engaged by the inwardly bent portion on said face plate when a portion of the latter is bent to form a corner and extend across an end of said body portion.

2. The curtain holder of claim 1 wherein said insert has ribbed surfaces to increase its frictional grip in said socket.

3. The curtain holder of claim 1 including a rigid leaf in said face plate at the corner thereof for reinforcing said plate.

4. The curtain holder of claim 1 including reinforcing means extending longitudinally of said face plate, said reinforcing means being interrupted at said corner, and a metal leaf in said face plate at the corner thereof for reinforcing said plate.