

(No Model.)

5 Sheets—Sheet 1.

L. D. BENNER.
PAPER BAG MACHINE.

No. 397,772.

Patented Feb. 12, 1889.

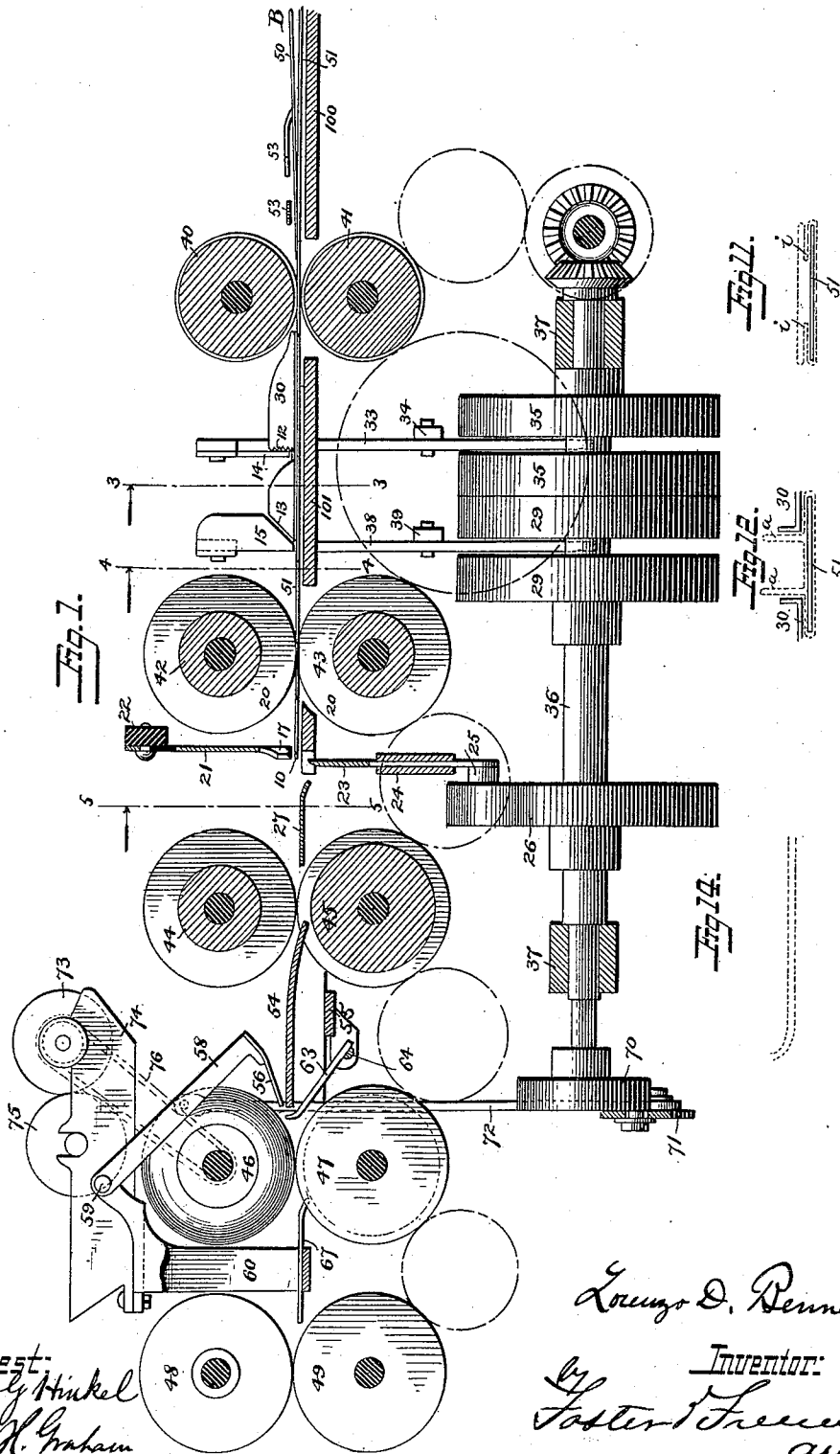

Attest:
Jno. Hinkel
Geo. N. Graham

Louise D. Benner,
Inventor:
Foster Freeman
att.

(No Model.)

5 Sheets—Sheet 2.

L. D. BENNER.
PAPER BAG MACHINE.

No. 397,772.

Patented Feb. 12, 1889.

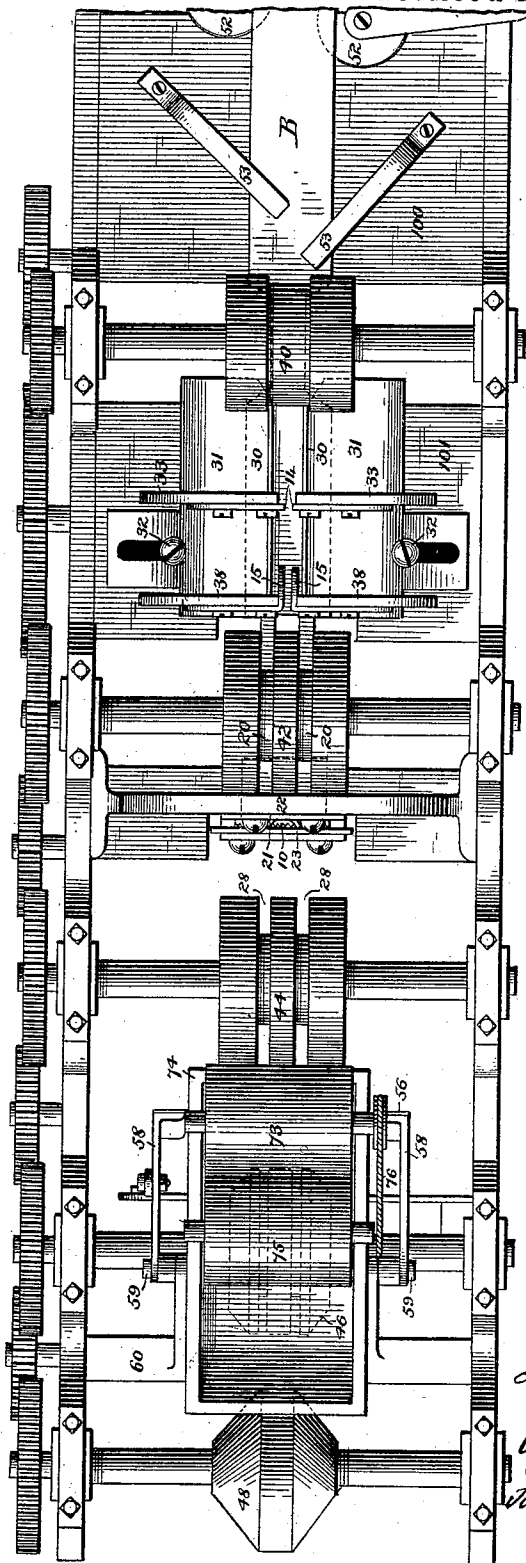

Fig. 2.

Attest:
Geo. Hinkel
L. M. Graham

Lorenzo D. Benner,
Inventor:
by Foster & Truman
attys

L. D. BENNER.
PAPER BAG MACHINE.

No. 397,772.

Patented Feb. 12, 1889.

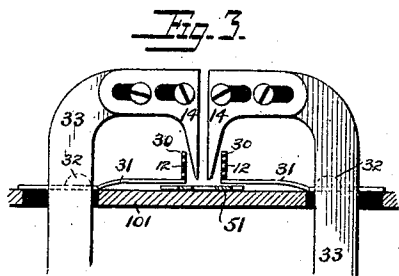

Fig. 3.

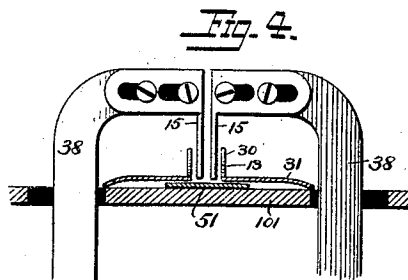

Fig. 4.

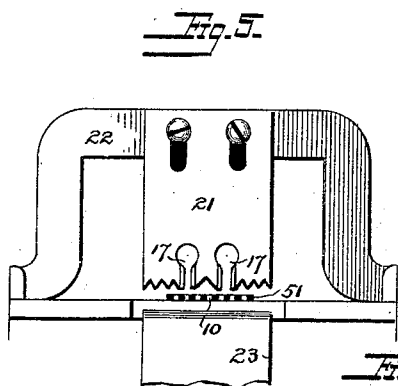

Fig. 5.

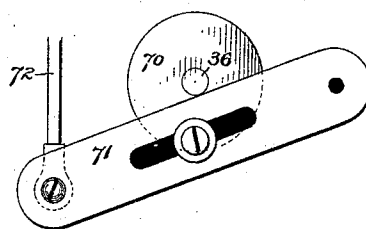

Fig. 6.

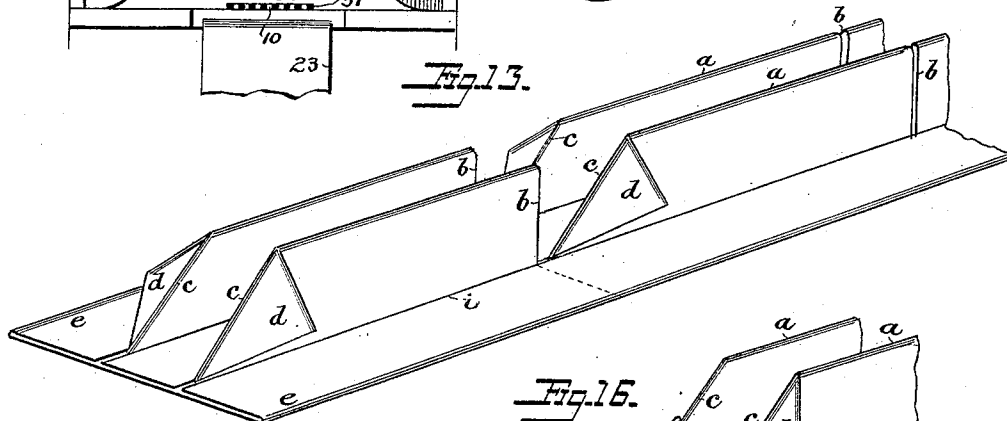

Fig. 13.

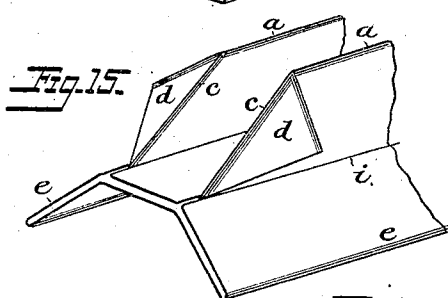

Fig. 15.

Fig. 16.

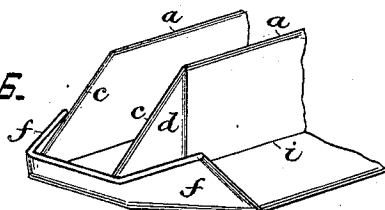

Fig. 17.

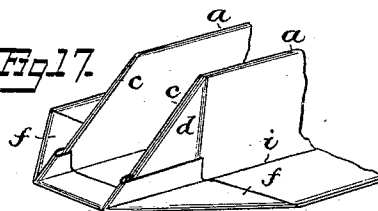
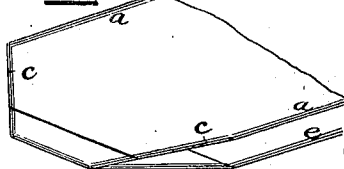

Fig. 18.



Attest:
 Geo. Hinkel Jr.
 Geo. M. Graham

Louis D. Benner,
 Inventor:
 by Foster & Shuman
 atty

L. D. BENNER.
PAPER BAG MACHINE.

No. 397,772.

Patented Feb. 12, 1889.

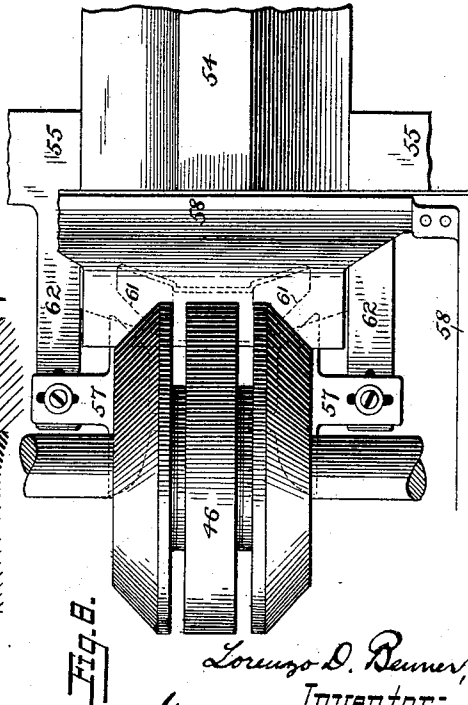
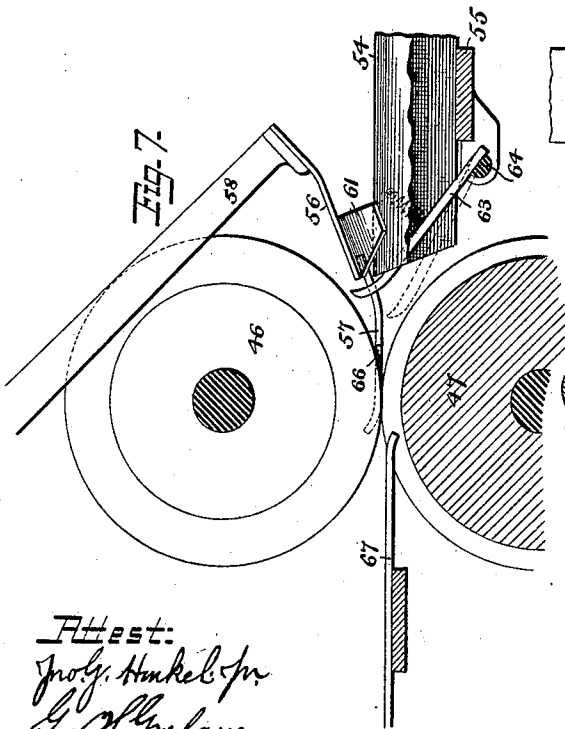
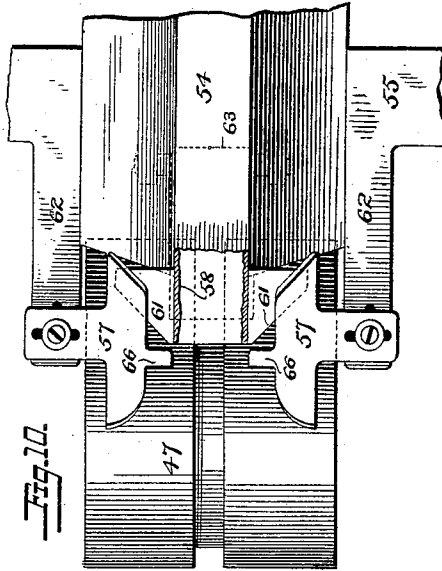
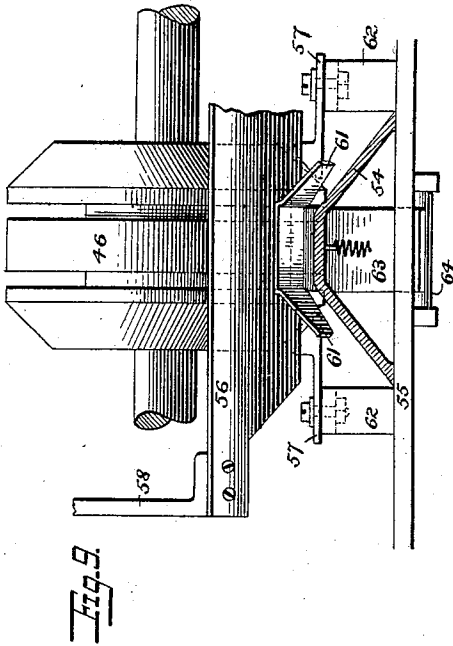

Attest:
 Prof. Hinkel for
 Geo. H. Krause

Lorenzo D. Benner,
 Inventor:
 by Foster & Freeman
 Atty

(No Model.)

5 Sheets—Sheet 5.

L. D. BENNER.
PAPER BAG MACHINE.

No. 397,772.

Patented Feb. 12, 1889.

Fig. 19.

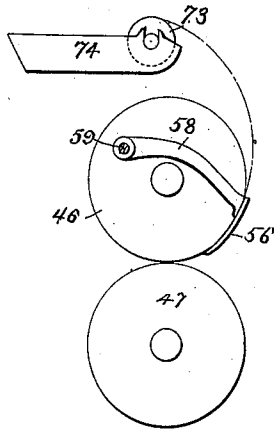

Fig. 21.

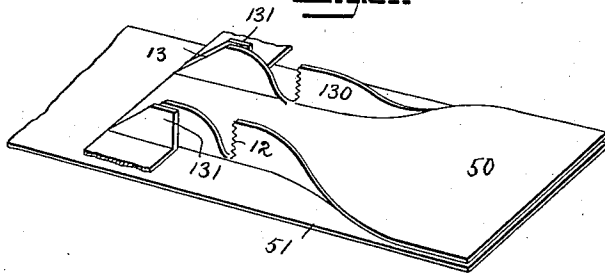
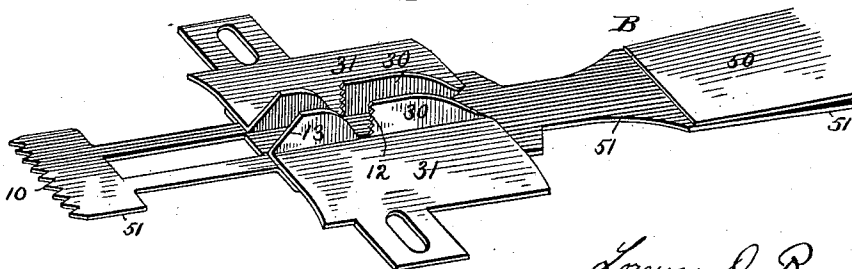

Fig. 20.



Witnesses.

Geo. G. Hinkel, Jr.
Geo. H. Graham

Lorenzo D. Benner,
Inventor.

Foster Freeman
Attorney &c

UNITED STATES PATENT OFFICE.

LORENZO D. BENNER, OF PEORIA, ILLINOIS, ASSIGNOR TO THE UNION PAPER BAG MACHINE COMPANY, OF PHILADELPHIA, PENNSYLVANIA.

PAPER-BAG MACHINE.

SPECIFICATION forming part of Letters Patent No. 397,772, dated February 12, 1889.

Application filed May 11, 1888. Serial No. 273,562. (No model.)

To all whom it may concern:

Be it known that I, LORENZO D. BENNER, a citizen of the United States, residing in Peoria, in the county of Peoria and State of Illinois, have invented certain new and useful Improvements in Paper-Bag Machines, of which the following is a specification.

The machine embracing the present improvements is designed to produce that class of paper bags made from a continuous flat tube having infolded sides or bellows folds, short sections of which tube forming bag lengths or blanks having one end closed to constitute bags that will open or distend into rectangular form.

The primary object of the present improvements is the organization, in a continuously-operating machine, of automatic devices adapted to the manufacture of the class of bags described and set forth in Letters Patent No. 304,403, granted to me September 2, 1884.

The accompanying drawings illustrate a machine embodying the improvements constituting the present invention, in which drawings—

Figure 1 is a longitudinal central sectional elevation of a bag-machine embodying my improvements. Fig. 2 is a plan view thereof. Figs. 3, 4, and 5 are transverse sections taken on the lines 3 3, 4 4, and 5 5, respectively, of Fig. 1; and Fig. 6 is an elevation of a crank-disk and immediate connections hereinafter referred to. Fig. 7 is an enlarged sectional elevation of the bottom-forming devices. Fig. 8 is a plan, and Fig. 9 is an end elevation, thereof; and Fig. 10 is a plan of the same, having the upper roll and the vibrating blade omitted for perspicuity sake. Figs. 11, 12, and 14 are diagrams hereinafter referred to. Figs. 13 and 15 to 18, inclusive, are perspective views of portions of the tube and bag-length, illustrating the operation of forming the bag-bottom and the laying of the bottom folds. Fig. 19 is a diagram of certain rolls and blade, hereinafter referred to. Fig. 20 is a perspective view of the former removed from the machine, and Fig. 21 is a similar view of a modified form of the same.

Like other machines of this character, it embraces a tubing mechanism adapted to

continuously convert a web of paper or other similar material into tubular form, feeding-rolls adapted to feed the tube onward, a severing device or devices for severing the tube transversely into bag lengths or blanks, bottom-folders suited to the folding over of certain portions of the ends of the bag-lengths to form the bag-bottoms, and pasting mechanism for applying paste to said portions or to the underlying material of the blanks to seal the bottom folds.

The web of paper in the form of a roll is supported in the usual manner at one end of the machine, and is led over a roll with one longitudinal edge traveling in contact with a paste disk that imparts a longitudinal line of paste thereto. From thence the web is led under a breaking-roll or directly under the heel of a former, B, and by suitable guiding devices coacting with the former is caused to gradually envelop the same, so that the opposite longitudinal edges of the web meet and lap each other over the center of the former and become united by said line of paste. As these features of a bag-machine are now so well known to those skilled in the art, and may in the present instance be of any of the known forms, no illustration or more specific description thereof is deemed necessary.

The former B is supported in the usual manner over a table, 100, and in the present machine is adapted to the formation of a bellows-sided tube. To this end it consists of two superimposed flat plates, 50 51, Fig. 20, separated at one end for a short distance by a central core to permit the material ultimately forming the bellows folds to be directed between the plates by side guides, 52, other guides or fingers, 53, serving to direct the opposite edges of the web over the center of the "former." The upper plate, 50, of the former terminates at some convenient point short of the feed-rolls 40 41, and the lower one, 51, is contracted to form a narrow neck to continue past said feed-rolls and contracted again to form a second narrow neck to pass a second set of feed-rolls, 42 43, and terminating at a convenient point beyond said last-mentioned feed-rolls in a serrated edge, 10. The feed-rolls 40 41 are each recessed centrally to permit the passage of the first neck

of the former, and are geared together to run in unison, and adapted to draw the web over and along the former and feed the completed tube onward.

5 In order to better impart the preliminary diagonal folds, hereinafter described, it has been found necessary to partially sever the tube to effect this result. Many modes of effecting this partial severance will present
10 themselves to a skilled mechanic, and hence I do not limit myself to the precise devices for this purpose now to be described. These devices in the present instance consist, essentially, of guides for turning the upper longitudinal edges of the tube at right angles to the remainder thereof, of severing devices for effecting a transverse severance of the upturned edges, and diagonal folders to impart diagonal creases or corner-fold lines to the
15 tube adjacent to said transverse severances. To this end the former B, between the two sets of feeding-rolls 40 41 and 42 43, passes over a table, 101, extending transversely between the side frames, and in connection therewith and extending above it there is provided a pair of vertically-arranged guides or lateral tube-supports, 30. These vertical guides project from plates 31, arranged upon
20 opposite sides of and partially overlying the former, and are adjustably secured upon the table by means of set-screws 32, passing through slots in said plates, so that the distance between said guides and their position in relation to the edges of the former may be readily adjusted. The upper ply and the bellows folds of the tube, after passing the end of the upper plate, 50, of the former, and beyond the bite of the feed-rolls, is free from the control of the former, and the rearward
25 ends of the vertical guides 30 are so shaped and positioned with respect to the inner folds, *i*, of the bellows sides that as said upper ply of the tube passes the feed-rolls the free longitudinal edges *a*, constituted by the upper
30 outer fold of the bellows sides, will be turned up at right angles to the remainder of the tube from the position shown in Fig. 11 to that shown in Fig. 12. Intermediate of the ends of these vertical guides 30 they abruptly terminate in a cutting-edge, 12, (see Figs. 1 and 3,) which may be either blunt, serrated, or sharpened, while the forward ends of the guides terminate in an inclined edge, 13. (See Figs. 1 and 4.) The cutting-edges 12 are
35 arranged transversely opposite each other, and with them coact a pair of vibrating cutters, 14, adjustably secured to the ends of vibrating arms 33, that are pivoted at 34 to brackets extending from the side frames, their lower ends being provided with studs which engage with suitably-shaped grooves in the face of the cams 35, one cam for each arm. These cams are mounted upon a longitudinally-arranged shaft, 36, supported in
40 brackets 37, extending transversely between the side frames of the machine. In their normal position the cutters 14 lie between the

vertical guides 30 and above the former, sufficient room being left between said guides and the cutters to permit the free passage of the longitudinally-folded edges *a* of the tube.
70 The effective edges of the cutters are slightly inclined, as shown in Fig. 3, so that in the act of partially severing the tube a shearing cut is obtained, and in this cutting movement
75 the arms 33 will be simultaneously vibrated so as to carry their cutters 14 suddenly across the face of the cutting-edges 12 and thus sever the opposite portions of the tube upon the lines *b*, as in Fig. 13, when said cutters
80 will be similarly vibrated in the opposite direction to their normal position between the vertical guides 30. Coacting with the inclined edges 13 is a pair of primary folders or creasers, 15, (see Figs. 1 and 4,) whose folding-edges are inclined in correspondence with the inclined edges 13. These primary folders are adjustably secured to the ends of vibrating arms 38, that are pivoted at 39 upon brackets extending from the side frames, and
85 at their lower ends are provided with studs engaging with suitably-shaped grooves in the cams 29, one cam for each arm, secured upon the longitudinal shaft 36. In their normal position these primary folders lie between the vertical guides 30 and above the former and are simultaneously vibrated at the proper times across the face of the inclined edges 13 in unison with the arrival of the incisions *b* at the forward end of the inclined edges, so as
90 to bend outwardly the end of the material of the vertically-extending portions of the tube immediately in rear of the incisions *b* and impart diagonal creases or corner fold-lines *c*, (hereafter forming the corner folds *d*.) when said primary folders will be vibrated back in the opposite direction to their normal position between the guides 30, from which it will be seen that the paper web is first formed into a bellows-sided tube, the opposite upper folds
95 thereof are turned up at right angles to the remainder of the tube, that the tube is transversely severed on said upturned portions, and then diagonal or corner creases or folds are imparted to the upturned portions. In practice these folders will contact with the vertical portions of the tube slightly in rear of the incisions *b*, and in folding the corner folds over the inclined edges of the guides will tear or break the tube on the fold-lines *i*
100 for a short distance, as indicated in Figs. 13 and 15, so as to leave a suitable projecting flap on the remaining portion of the tube forward of the corner folds.

The second pair of feeding-rolls, 42 43, are geared together to turn in unison, and are provided with a pair of grooves, 20, in line to permit the unobstructed passage of the vertical extending portions of the tube, and in passing through said grooves the corner folds, *d*, will contact with the face of the roll 42 and be laid back in contact with the adjacent surface of said vertically-extending portions and thus lay the folds. In order to se-

cure these corner folds in this position, of course suitable pasting mechanism may be provided near the entrance to the feed-rolls 42 43, or adjacent to the inclined edges 13 of the vertical guides, so that as the diagonal lines *c* are being defined by the primary folders the free edges of the tube may be directed in contact with the pasting appliance, and thus have imparted to them suitable lines of paste. As such pasting appliances may be of any of the well-known forms, it is not thought necessary to illustrate or set forth the same herein.

Over the serrated end 10 of the former is mounted a transverse cutting-plate, 21, adjustably secured to a bridge, 22, spanning the space between the side frames and secured thereto. This cutting-plate (see Fig. 5) is provided with a pair of slots, 17, in line to permit the free passage of the vertical portions of the tube, and upon its lower end is provided with a cutting-edge, preferably occupying a position just in rear of the end of the former, so as to impart, when the tube is severed, a projecting flap upon its under ply at the forward end of the tube and ultimate bag-length. Coacting with these two transverse cutting-edges is a reciprocating cutting-blade, 23, that normally lies immediately below the end of the former. This cutting-blade is mounted to reciprocate in suitable guides formed in a transverse bracket extending between the side frames of the machine, and is provided with an arm having a stud, 25, that engages with a suitably-shaped groove in a cam-wheel, 26, by which the blade is reciprocated to sever the tube transversely into bag-lengths upon lines approximately coincident with the incisions *b*. Of course other severing devices—such as a rotary striker—may be employed without departing from the essential features of this invention. The bag-lengths thus severed from the tube are guided by a plate, 27, between a pair of rolls, 44 45, that are geared together to run in unison, the upper one of which is provided with a pair of slots, 28, to permit the free passage of the vertically-extending portions of the bag-length and feed it forward over a table, 54. This table 54 is secured upon a cross-bar, 55, and bridges the space between the forwarding-rolls 44 45 and the fold-laying rolls 46, 47, and forms a suitable support for the bag-lengths during the formation of the bottom folds. In its preferred form this table has a narrow horizontal surface, substantially of the width of the tube, lying between the inner folds of the bellows sides, the opposite sides thereof being inclined downward, as shown in Fig. 9, for a purpose which will hereinafter appear.

The bottom folding devices consist, substantially, of said fold-laying rolls 46 47, a vibrating blade, 56, and a pair of fold-laying plates, 57. The vibrating blade 56 is carried by a pair of arms, 58, pivoted upon studs 59, projecting from brackets extending from a transverse bridge-piece, 60, as seen in Figs. 1

and 2. Suitable vibrations are imparted to this blade by a crank, 70, coacting with a pivoted arm, 71, connected to the blade by a connecting-rod, 72. (See Figs. 1 and 6.) The under side of the vibrating blade 56 is provided with a superposed plate secured thereto having oppositely-extending angular wings 61, the said plate and its wings partaking of the shape of the table 54 in cross-section. The forward edges of the wings 61 are inclined, as shown in Figs. 7, 8, and 10, so as to coincide with the diagonal fold-lines ultimately imparted to the opposite edges of the end of the bag-length. The fold-laying plates are adjustably secured upon the ends of brackets 62, extending from the cross-bar 55, and are arranged upon opposite sides of the central line of the travel of the bag-length. The forward ends of these plates extend beyond the bite of the fold-laying rolls and are provided with upwardly-curved ends to permit the sides *e* of the bag-blank to pass beneath them. There is also provided a spring-seated plate, 63, projecting at the end of the table 54 slightly above its surface. This spring-seated plate is mounted upon a transverse rock-shaft, 64, properly supported in bearings extending from the cross-bar 55, and its projecting end is adapted to be contacted by the end of the blade 56 and rocked down into the position shown in dotted lines, Fig. 7, so as to permit the forward movement of the bag-length. With this understanding of the bottom-forming devices their operation in imparting the bottom folds to the bag-length will now be described.

The forward end of the bag-length in moving over the table 54 will contact with the end of the spring-seated plate 63 and have its end turned upward, as shown in Fig. 14. At the time this occurs the blade 56 will have been vibrated downward, so that its end contacts with this upwardly-turned end of the bag-length substantially in the position shown in Fig. 7. This movement of the blade 56 causes the wings 61 to press upon the longitudinal sides of the bag-length and direct them against the inclined surfaces of the table 54, so as to incline the longitudinal edges *e* in the manner shown in Fig. 15. In this position of the material of the bag-length the upwardly-turned ends thereof will have contacted with the curved ends of the fold-laying plates 57, so as to cause the corners *f* of said ends to bear against the inclined front edges of the wings 61 and then turn upward, as in Fig. 16, on diagonal lines defined by said inclined edges of the wings. As the bag-blank moves forward, and the blade 56 and the wings 61 follow it, said corner folds will be laid down upon the adjacent surface of the bag-length until the end of the same meets the bite of the fold-laying rolls 46 47, when the forward movement of the blade and wings will be stopped and their return movement immediately commenced. In passing between the rolls 46 47 the central portion of the

upturned end of the blank will be laid down in contact with the adjacent surface of the bag end, as indicated in Fig. 17, and complete the laying of the bottom folds. In order to insure the complete laying of the corner folds, *f*, the fold-laying plates 57 are provided with laterally-extending tongues 66, whose ends lie in lines coincident with the inner folds, *i*, of the bellows sides, and hence as the corner folds, *f*, pass under the plates their tongues 66 will bear against the inner portions of said folds, so as to impart a creased line thereto corresponding with the said inner fold of the bellows side and insure the snug laying of the material, so that the vertically-extending portions *a* of the bag-lengths may be readily returned to their normal position against the portions *e* and lie flat in substantially the same manner shown in Fig. 18. In order to impart suitable lines of paste to these bottom folds to secure them in position when folded, the blade 56 will be vibrated to contact with a paste-roll, 73, turning in a vat, 74, which may also have a paste-laying roll, 75, turning in contact with said roll 73. Motion may be imparted to said rolls by an endless band or cord, 76, transmitting motion from the shaft of the roll 46.

The operation of the blade 56 may be so timed and the path of its vibrating movement may be so arranged that the vertically-extending portions *a* of the bag-length will not be turned down by the action of the blade and roll 46—as, for instance, in the manner shown in the diagram Fig. 19—and when this is the case said roll will be provided with a pair of grooves, as shown in Figs. 8 and 9, to permit the free passage of said portions of the bag-length, after passing which the bag will be directed by a guide, 67, between delivering-rolls 48 49, the upper one of which is provided with a narrow bearing-face and conical sides to lay the bag in its flat condition. (Shown in Fig. 18.) When, however, the blade 56 is pivoted in the manner shown in the other figures of the drawings, its under face will contact with the ends of the vertically-extending portions of the bag-length and turn them slightly from their vertical positions, so that the face and conical sides of the roll 46 will lay said portions down and deliver the bag in its complete condition, as shown in said Fig. 18, in which case the rolls 48 49 and the guide 67 may be dispensed with.

One of the essential characteristics of the described embodiment of these improvements is that the machine is also adapted to the manufacture of the well-known bellows-sided square bag after the patent to Crowell, No. 123,811, and hence that by simple changes one machine is capacitated to the manufacture of two styles of bags. The change necessary to the making of such square bags will simply consist in removing or sliding back from operative position the guides 30 and rendering inoperative the cutters 14 and primary folders 15, in which case the cutter 23 will

wholly sever the tube, and in removing the plate providing the wings 61 from the blade 56 and withdrawing the fold-laying plates 57 from operative position, so as to permit the blade 56 to make the ordinary transverse fold at the end of the bag-lengths.

Instead of the guides 30 being independent of the former, the upper plate, 50, thereof may be extended beyond the feed-rolls 40 41, so that its opposite edges may be gradually curved upwardly into vertical guides 130, as indicated in Fig. 21, and the cutting-edges 12 may be provided by the ends thereof, while the inclined edges 13 may be also provided by extensions of said upturned portions of the plate 50, in which case, however, it may be necessary to supplement them with outer guides, 131, having similar inclined edges, so that both plies of the tube will be creased during the action of the primary folders. So, also, instead of vibrating the cutters 14 and folders 15 from a position between the guides 30, they may be vibrated in the reverse direction and effect the same purpose, the only difference being that instead of the corner folds, *d*, being laid outwardly of the upturned portions *a* they would be laid inwardly of said portion and lie upon the outside of the blank instead of within the bellows folds.

The described vibratory cutters for primarily severing the tube might be substituted by rolling cutters or cutters carried by a roll, as one of the rolls 40 41, more fully set forth in an application filed March 21, 1888, Serial No. 267,944.

What I claim is—

1. In a paper-bag machine, the combination of a former adapted to form a web of paper into a bellows-sided tube, guides for turning the opposite upper plies of the tube at right angles to the remainder of the tube, and severing devices for severing both the upturned and flat portions, substantially as described.

2. In a paper-bag machine, the combination of a former adapted to form a web of paper into a bellows-sided tube, guides for turning the opposite upper plies of the tube at right angles to the remainder of the tube, transverse severing devices for severing said upturned portions, and diagonal creasing or folding devices for creasing or folding the ends of said severed upturned portions of the tube, substantially as described.

3. In a paper-bag machine, the combination of a former adapted to form a web of paper into a bellows-sided tube, guides for turning the opposite upper plies of the tube at right angles to the remainder of the tube, transverse severing devices for severing said upturned portions, diagonal creasing or folding devices for creasing or folding the ends of said severed upturned portions of the tube, a second severing device for severing bag-lengths from the tube, and bottom-folding devices for forming the bag-bottoms, substantially as described.

4. The combination of a former adapted to

form a bellows-sided tube, guides for turning the opposite upper plies of the tube at right angles to the remainder of the tube, severing devices for severing said upturned portion, 5 primary folders in advance of said severing devices for creasing or folding the corners of said upturned portions, and a second severing device in advance of said primary folders for completing the severing of bag-lengths 10 from the tube, substantially as described.

5. The combination of guides for turning the opposite upper plies of a bellows-sided tube at right angles to the remainder of the tube, a pair of cutters coacting with said 15 guides to sever said upturned portions transversely, diagonal creasing or folding devices for creasing or folding the ends of said severed upturned portions, a transverse severing device for severing bag-lengths from the 20 tube, and folding devices for completing the formation of the bag-bottom, substantially as described.

6. The combination of guides for turning the opposite upper plies of a bellows-sided 25 tube at right angles to the remainder of the tube, transverse severing devices for severing said upturned portions, a pair of angular creasing-edges and creasers coacting therewith for diagonally creasing or folding the 30 ends of said severed upturned portions, a transverse severing device for severing bag-lengths from the tube, and folding devices for completing the formation of the bag-bottoms, substantially as described.

35 7. The combination of the former, the guides 30, independent of said former and terminating in cutting-edges, and laterally-vibrating

cutters coacting with said edges, substantially as described.

8. The combination of the guides 30, severing devices, angular creasing-edges 13, and 40 laterally-vibrating creasers or folders coacting with said edges, substantially as described.

9. The combination of the guides 30, terminating in cutting-edges, laterally-vibrating 45 cutters coacting with said cutting-edges, angular creasing-edges 13, and laterally-vibrating creasers or folders coacting with said creasing-edges, substantially as described.

10. The combination, with tube-feeding devices and guides for turning the opposite upper plies of the tube at right angles to the remainder of the tube, of a transverse cutter provided with vertical openings 17, and a severing-blade coacting with said cutter, substantially 55 as described.

11. The combination, with tube-feeding devices and transverse severing devices, of an oppositely-inclined table, 54, folding-rollers, and a folding-blade coacting therewith, substantially 60 as described.

12. The combination, with tube-feeding devices and transverse severing devices, of an oppositely-inclined table, 54, folding-rollers, and a folding-blade having wings 61, coacting 65 with said table and rollers, substantially as described.

In testimony whereof I have signed my name to this specification in the presence of two subscribing witnesses.

LORENZO D. BENNER.

Witnesses:

P. F. HARMON,
GEO. M. GIBBONS.