

(19) World Intellectual Property Organization
International Bureau



(43) International Publication Date
29 September 2011 (29.09.2011)

(10) International Publication Number
WO 2011/116440 A1

- (51) International Patent Classification:
F03D 3/06 (2006.01) *F03D 3/00* (2006.01)
- (21) International Application Number:
PCT/BR2010/000200
- (22) International Filing Date:
24 June 2010 (24.06.2010)
- (25) Filing Language: English
- (26) Publication Language: English
- (30) Priority Data:
P11000815-2 23 March 2010 (23.03.2010) BR
- (72) Inventor; and
- (71) Applicant : **DULCETTI FILHO, Flávio Francisco**
[BR/BR]; Av. Generalissimo Deodoro, No.805 Apto
1502, NAZARÉ, 66050-160 Belém (BR).
- (74) Agent: **LLC INFO CONNECTION LTDA.**; Av. Ayrton
Senna, 3.000 Sala 205 Bloco 2, Via Parque Offices, Barra
Da Tijuca, 22775-003 Rio De Janeiro (BR).

AO, AT, AU, AZ, BA, BB, BG, BH, BR, BW, BY, BZ, CA, CH, CL, CN, CO, CR, CU, CZ, DE, DK, DM, DO, DZ, EC, EE, EG, ES, FI, GB, GD, GE, GH, GM, GT, HN, HR, HU, ID, IL, IN, IS, JP, KE, KG, KM, KN, KP, KR, KZ, LA, LC, LK, LR, LS, LT, LU, LY, MA, MD, ME, MG, MK, MN, MW, MX, MY, MZ, NA, NG, NI, NO, NZ, OM, PE, PG, PH, PL, PT, RO, RS, RU, SC, SD, SE, SG, SK, SL, SM, ST, SV, SY, TH, TJ, TM, TN, TR, TT, TZ, UA, UG, US, UZ, VC, VN, ZA, ZM, ZW.

(84) Designated States (unless otherwise indicated, for every kind of regional protection available): ARIPO (BW, GH, GM, KE, LR, LS, MW, MZ, NA, SD, SL, SZ, TZ, UG, ZM, ZW), Eurasian (AM, AZ, BY, KG, KZ, MD, RU, TJ, TM), European (AL, AT, BE, BG, CH, CY, CZ, DE, DK, EE, ES, FI, FR, GB, GR, HR, HU, IE, IS, IT, LT, LU, LV, MC, MK, MT, NL, NO, PL, PT, RO, SE, SI, SK, SM, TR), OAPI (BF, BJ, CF, CG, CI, CM, GA, GN, GQ, GW, ML, MR, NE, SN, TD, TG).

Published:

— with international search report (Art. 21(3))

(81) Designated States (unless otherwise indicated, for every kind of national protection available): AE, AG, AL, AM,

(54) Title: VERTICAL WIND TURBINE WITH ARTICULATED BLADES

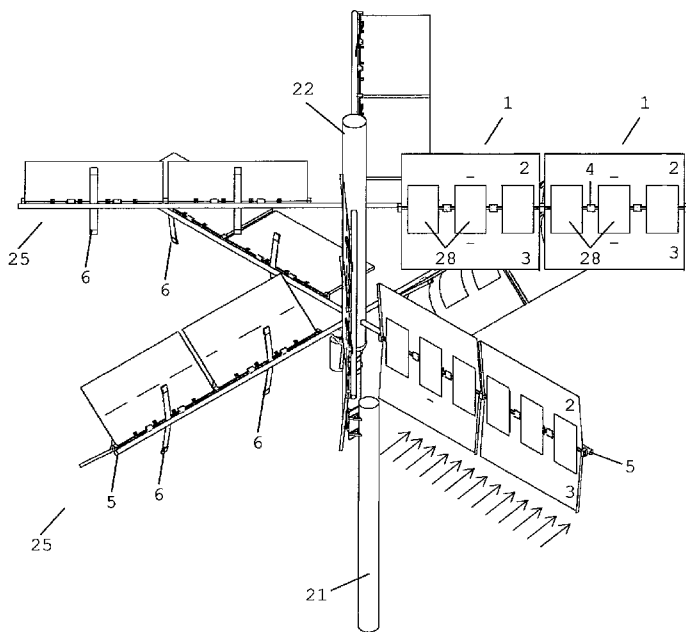

FIG. 14

(57) Abstract: A vertical wind turbine to catch the wind force characterized by its system of aerodynamic panels are provided with blades fixed into horizontal axis that open and close simultaneously and symmetrically upward and downward due the gears like the butterfly wings rotated by 90 degrees of its normal position, it is like opens an umbrella horizontally to receive on one side the wind buoyance or pressure and in the other side close by the action of the wind. The top and bottom blades works as counterweight one to another both to open and close (flatness) which makes your weight null in relation to the effort of wind to open or close them independent of the self-weight of the blades what propitiate the maximum use of the wind force in the traction side without loss to the return of the blades to the traction position driving a vertical axis.

WO 2011/116440 A1

VERTICAL WIND TURBINE WITH ARTICULATED BLADES**FIELD OF THE INVENTION**

The present invention, as a vertical wind turbine, is applied in the electric power generation by transforming the wind energy into rotational mechanical energy in a controlled way, starting equipments for electric power generation or hydraulic pumps, as well as rotors in general, or anything that can be moved rotationally by the wind force.

10 STATE OF THE ART

The traditional windmills are characterized by having propellers which rotate vertically in parallel to the equipment sustaining post, and directly connected to the generator axis or by shells which rotate in the horizontally direction perpendicular to the post, connected to a vertical rotational axis.

In the case of the propellers, they revolve solely by a component (fraction) of the wind force resultant that, by the angular step variation, provides a perpendicular rotation in relation to the wind direction.

The aerodynamic surfaces of the blade propeller besides profiting only one component of the wind force, have very small area compared to the circle described by its movement and this configuration cannot increase the yield using multiple propellers to boost the same axis in a catchment area of wind per square meter due to aerodynamic interaction and structural constraints since propellers have great length, are build with heavy materials and are merely fixed in only one point into a spinner and still need to be moved to the control of the step.

The propellers require relatively strong winds, for example 8 m/s, for its operation and when the winds are very

strong the propellers come under "Stol" stopping the turbine.

The propellers were developed primarily for producing the air mass displacement, i.e. to move the wind and not to be moved by the wind, situation where they are inefficient because the resulting from the work of the wind is expressed by the force on area and propellers are thin with small areas of catch.

In the case of shells, the problem is more serious, because they have the same aerodynamic surface in your front and back sides only with the different drag coefficients reason by why the resulting rotational force is extremely small which further reduces the efficiency of this method of catch the force of the wind.

The turbines that transform the speed of the wind into mechanical rotation of patent the applications filed internationally under the numbers PCT/BR2006/000260 and PCT/2008/000218 revolve by the resulting of the force between the difference of force obtained in the traction side produced by the wind on the upright panel and locked in his traction stoppers, and the force lost with the panel wind drag that will be raised by the pressure of the wind at its back to flat the opposite side.

Thus, in the present conception when the aerodynamic panel reaches the position where the wind beats in its back, how much lighter it is in relation to the wind force to raise the panel and flat it bigger will be the force gain obtained in the upright panel that receives the wind in its front face.

By this situation this system, for its perfect functioning, it needs one of the following options:

- a) That the panels be constructed with lightweight materials, and, preferably, be rectangular panels with low high compared with its width in order to reduce the

wind effort needed to raise them, once, approximately, a half of the panel weight shall be transmitted to the hinges support and the other half of the panel weight will be raised by the pressure of the wind to be flattened.

5

b) In the case that lightweight materials cannot be used so that resist for long periods, the panels can be provided with counterweights or springs capable of making them lighter in relation to the effort of wind to flat them and preferably limiting the height in relation with the width to minimize the effort to flat the panels.

10

As an example, consider a wind of 4 m/s which is equivalent with approximately a 1 kg/m² force on the panel. Then, if the self-weight of the panels is 2 kg/m² and this panel doesn't have springs or counterweights to reduce their weight to flat the panels, the system would be stopped without rotating, as if the two sides, the traction side and the opposite side, were locked.

15

Faced with this situation, we have small panels compared width heights, becoming necessary for the cases of greater power, the use of a greater number of sets of crosses and arms which makes the turbine slightly more costly.

20

Due the panel works only under the horizontal arm, when it exits the horizontal or flat position to the upright or vertical position and arrives at the stopper, it produces an twisting force on the arm (or horizontal axis), which requires greater robustness in the structure of the arm making the turbine little more expensive.

25

30

In order to solve the problems cited above was developed the present vertical wind turbine that presents an aerodynamic panels system capable of providing large catchment areas of the wind force into only one tower and

that uses simple and cheaper materials for its construction and which has no aerodynamic and structural limitations to expand the necessary capacity of power required in a single tower and has no aerodynamic panels mono supported and also
5 do not require great wind effort due to the weight of the aerodynamic turbine panels both to flat them in the opposite side of the wind direction, as to open them in a vertical position in the traction side, i.e., the wind effort to the operation of these aerodynamic panels independent of the
10 mass or the self-weight of the material which the panels are built.

The aerodynamic panels will always have its weight, to open them or close them in relation to the wind force, near to zero.

15 As the panels can be produced with materials more robust, the durability problem was also simpler solved.

The new aerodynamic panels system also solved the problem of the twist force in the turbine arms when the panels are in its traction position (vertical), because they
20 work with two blades moving in opposite directions and in a synchronized way nullifying the twist force in the arms (or horizontal axes).

SUMMARY OF THE INVENTION

The present vertical wind turbine has as main feature
25 be constituted by various aerodynamic panels that are opened being in an upright position by the exclusive action of the wind in their front face producing a spin movement around the vertical axis pivot and that be closed by the action of the wind at their back face during the contrary wind course
30 producing the lowest possible drag.

Thus, there are two distinct sides in relation to the wind direction. One is the buoyancy or traction side (panels open forming like a wall) and the other side is the

flattening inactive or drag side (panels closed with minimum drag being only the attack edge surface of the horizontal axis in the opposite direction against the wind).

The panels are composed by two aerodynamic surfaces that are open simultaneously and symmetrically one upwards and the another downwards by the action of wind in their front face and that are closed simultaneously and symmetrically from the bottom to the top and from the top to the bottom, by the action of the wind at their back as they were a single aerodynamic horizontal surface.

Each Panel is composed of two blades, each one attached to a horizontal axis with bearings at the ends, and between the two parallel horizontal axes near each other there are one or more gears, depending on the size of the axis, to link the movement of the upper blade with the lower blade doing that the blades open and close with symmetrical movement, with the goal of the lower blade when moving by the action of the wind goes down and opening almost to the vertical position, and serve as a counterweight to the top blade that is opening and rising symmetrically with the down blade by the action of the gears between the axis.

Similarly when the plate is moving to the side on which the wind reaches its back, the upper blade when it is down to close, the upper blade serves as a counterweight to the lower blade that is rising symmetrically for the two blades meet each other forming almost as a single blade horizontally to not cause aerodynamic drag in the inactive side or flatted side.

The blades fixed into horizontal axes open and close like butterfly wings as a butterfly turned in 90 degrees, or like an umbrella opened horizontally when receive in one side the buoyancy produced by the wind force and in the other side be closed by the action of the wind.

The aerodynamic blade surfaces can, if necessary, have an angulation on its borders, so as to allow them to open when they enter in traction cycle (active cycle) and close when enter in the flatten cycle (inactive cycle) to obtain
5 the full recovery of the wind force in the 180 degrees of the traction cycle and in the 180 degrees of the inactive cycle.

The blades, both upper and lower, may contain, in the centre of its extremities, opposite to the horizontal axes,
10 electromagnetic coils that are energized by a supervision and control system to maintain the blades horizontally or flatted regardless of the wind direction in order to prevent situations of storm or even to stop the turbine for maintenance.

The blades can contain, in its vertex aperture angle (meeting point between the two blades), a canvas or rubber flexible jacket in order to reduce the wind escape through its rotating fixing horizontal axis. In cases of major wingspan, in which the structure of the panels fixation arms
15 be opened against the wind direction and closed in the wind direction, it will not be necessary the use of flexible jackets, since that the own arm will exert the function of collaborating in take the wind force in the desired rotation direction.
20

The panels are fixed to the cross let arms which rotates on a vertical axis or on a vertical structure.
25

To set the rotation direction of the turbine, if the panels are positioned in their open condition on the right side of the vertical axis, the turbine will rotate in a
30 counter-clockwise sense, because these panels will be close to the left side of the vertical axis to be flatted or horizontally. And when the panels are placed to open on the left of the vertical axis the turbine rotates in the clockwise sense.

Once programmed the turbine rotation direction it will remain in the same rotation direction regardless of the wind direction.

Each horizontal arm or axis may receive one or more sets of aerodynamic traction panels. Each Panel is composed by two blades, one upper blade (2) moves in a 1/4 circle course from the horizontal position to upwards and the inferior blade (3) moves in a 1/4 circle course from the horizontal position to down symmetrically with the upper blade (2).

This system has no structural or aerodynamic limits to the horizontal arms or axis size, to the quantity of panels and to the number of levels of crossarms with panels.

Each panel composed by two aerodynamic blades is exclusively moved by the action of the wind and doesn't have any mechanical system of interdependence between the panels in the same arm or between panels from the traction side and the inactive side or horizontally side.

The big advantage of this system, type synchronized via gearing butterfly, is that the panels both to open as to be closed independent of their mass (weight) and material that are constructed, because they have always zero weight in relation to the work of the wind force to open them or close them due also to the function as counter-weight of each panel blade, resulting in the maximum use of wind force practically with zero percent of loss of the buoyancy obtained in the traction side in relation to the inactive side (only the area equivalent to the attack edge of the inactive side flattened or closed will produce a despicable drag).

This means that winds with low speeds will already produce a considerable gap between the buoyancy obtained in the traction side and the loss almost zero in the drag side, i.e., with a little wind speed the system rotates and comes

into operation, which is beneficial too to the regions that have low-speed winds, because this system is low cost construction compared to the systems currently used and has no limits to expand the catchment area to compensate the
5 reduction of the wind speed.

These panels may have a control of the wind catchment area in each one of the blades from a set of aerodynamic panels with the simple sliding of a second blade sliding over the other in both upper and lower plate symmetrically
10 to slide through the command of a servo motor on each panel blade open or close roles growing and decreasing the wind catchment area of each panel blade aerodynamic enabling the speed control and the torque of the turbine in areas where the wind speed varies greatly.

15 This vertical wind turbine captures the wind force in any direction not requiring equipment, sensors, windsock, engines, etc to redirect it to the wind direction.

Another advantage is that when the system opens by the wind pressure, by having symmetric surfaces, it not produces
20 a twist in the support arm or horizontal axis.

The panels, when it opens symmetrically, due the work of the gears between them, with a counterweight effect, they became restricted almost in a vertical position through rubber stops fixed on bars attached to their arms to up and
25 to down, or through elastic rope passing on a central axis that are between the panels with a pulley which gives passage rope which is fixed at the ends of the panels thus limiting the maximum opening, which also helps avoid noises when the blades reach its end of the course.

30 The present invention may have several embodiments according to the energy production capacity desired.

In order to better describe the invention and its possible embodiments follows the description of the drawings

and a detailed description of the invention based on the embodiments.

DESCRIPTION OF THE FIGURES

FIGURES 01A, 01B and 01C - perspective views of the movement evolution of the aerodynamic panels with limiter system implemented by backstop. In the Figure 01A the aerodynamic panels are fully closed. In the Figure 01B the aerodynamic panels are 50% open. In the Figure 01C the aerodynamic panels are fully open, demonstrating that the backstops are limiting its openness.

FIGURES 02A, 02B, and 02C - superior views of the movement evolution of the aerodynamic panels with limiter system implemented by backstop. In the Figure 02A the aerodynamic panels are fully closed. In the Figure 02B the aerodynamic panels are 50% open. In the Figure 02C the aerodynamic panels are fully open, demonstrating that the backstops are limiting its openness.

FIGURES 03A and 03B - lateral views of the movement evolution of the aerodynamic panels with limiter system implemented by backstop. In the Figure 03A the aerodynamic panels are 50% open. In the Figure 03B the aerodynamic panels are fully open, demonstrating that the backstops are limiting its openness.

FIGURES 04A, 04B and 04C - perspective views of the movement evolution of the aerodynamic panels with limiter system implemented by cables. In the Figure 04A the aerodynamic panels are fully closed. In the Figure 04B the aerodynamic panels are 50% open. In the Figure 04C the aerodynamic panels are fully open, demonstrating that the cables are limiting its openness.

FIGURES 05A, 05B, and 05C - superior views of the movement evolution of the aerodynamic panels with limiter system

implemented by cables. In the Figure 05A the aerodynamic panels are fully closed. In the Figure 05B the aerodynamic panels are 50% open. In the Figure 05C the aerodynamic panels are fully open, demonstrating that the cables are limiting its openness.

FIGURES 06A and 06B - lateral views of the movement evolution of the aerodynamic panels with limiter system implemented by cables. In the Figure 06A the aerodynamic panels are 50% open. In the Figure 06B the aerodynamic panels are fully open, demonstrating that the cables are limiting its openness.

FIGURE 07 - perspective detailed view of the aerodynamic panels with limiter system by cables demonstrating the gears and the central axis responsible for support the cables.

FIGURE 08 - lateral view of the AA cut in the figure 05C with the gears details.

FIGURE 09 - right lateral perspective view of the aerodynamic panels with limiting system by cables demonstrating the gears and the central axis responsible for support the cables.

FIGURE 10 - detailed view of the support axis of the limiting cables of the aerodynamic panels course showing the functioning of the pulleys by where the cables pass trough. Figure 10A is a top view of the axis. Figure 10B is a view of the BB cut of the axis. Figure 10C is a lateral view of the axis.

FIGURE 11 - front view of the aerodynamic panels fully open showing the option of the panels to have holes that can be opened and closed by means of a plate powered by servomotors thereby changing the catchment area of wind force and enabling the control of the turbine rotation.

FIGURE 12 - superior detailed perspective view of the aerodynamic panel showing the option of the panels to have holes that can be opened and closed by means of a plate powered by servo-motors thereby changing the catchment area of wind force and enabling the control of the turbine rotation. This figure demonstrates how a plate sliding behind the panel allowing open and close the holes.

FIGURE 13 - perspective view of the aerodynamic panels fully open showing the option of the panels to have holes that can be opened and closed by means of a plate powered by servo-motors thereby changing the catchment area of wind force and enabling the control of the turbine rotation.

FIGURE 14 - perspective view of the first embodiment of the vertical wind turbine where this system is coupled to a lamppost and has a generator in its basis to the energy production. The aerodynamic panels are using the course limitation through backstops. The arrows show the wind direction.

FIGURE 15 - front view of the first embodiment of the vertical wind turbine where this system is coupled to a lamppost and has a generator in its basis to the energy production. The aerodynamic panels are using the course limitation through backstops. The arrows show the wind direction.

FIGURE 16 - superior view of the first embodiment of the vertical wind turbine where this system is coupled to a lamppost and has a generator in its basis to the energy production. The aerodynamic panels are using the course limitation through backstops. The arrows show the wind direction.

FIGURE 17 - perspective view of the first embodiment of the vertical wind turbine where this system is coupled to a

lamppost and has a generator in its basis to the energy production. The aerodynamic panels are using the course limitation through cables. The arrows show the wind direction.

5 **FIGURE 18** - front view of the first embodiment of the vertical wind turbine where this system is coupled to a lamppost and has a generator in its basis to the energy production. The aerodynamic panels are using the course limitation through cables. The arrows show the wind
10 direction.

FIGURE 19 - superior view of the first embodiment of the vertical wind turbine where this system is coupled to a lamppost and has a generator in its basis to the energy production. The aerodynamic panels are using the course
15 limitation through cables. The arrows show the wind direction.

FIGURE 20 - cut front view of the first embodiment of the vertical wind turbine detailing the rotary hollow cylindrical cover.

20 **FIGURE 21** - perspective view of the second embodiment of the vertical wind turbine. The aerodynamic panels are using the course limitation through backstops. The arrows show the wind direction.

FIGURE 22 - front view of the second embodiment of the
25 vertical wind turbine. The aerodynamic panels are using the course limitation through backstops. The arrows show the wind direction.

FIGURE 23 - superior view of the second embodiment of the vertical wind turbine. The aerodynamic panels are using the
30 course limitation through backstops. The arrows show the wind direction.

FIGURE 24 - perspective view of the second embodiment of the vertical wind turbine. The aerodynamic panels are using the course limitation through cables. The arrows show the wind direction.

5 **FIGURE 25** - front view of the second embodiment of the vertical wind turbine. The aerodynamic panels are using the course limitation through cables. The arrows show the wind direction.

FIGURE 26 - superior view of the second embodiment of the
10 vertical wind turbine. The aerodynamic panels are using the course limitation through cables. The arrows show the wind direction.

FIGURE 27 - lateral cut view of the second embodiment of the vertical wind turbine. Show the details of the hollow
15 cylindrical cover, post and the elements inside the base that represents the electrical power generator set.

FIGURE 28 - front view of the second embodiment of the vertical wind turbine equipped with fixtures. The aerodynamic panels are using the course limitation through
20 backstops. The arrows show the wind direction.

FIGURE 29 - perspective view of the second embodiment of the vertical wind turbine equipped with fixtures. The aerodynamic panels are using the course limitation through backstops. The arrows show the wind direction.

25 **FIGURE 30** - front view of the second embodiment of the vertical wind turbine equipped with fixtures. The aerodynamic panels are using the course limitation through cables. The arrows show the wind direction.

FIGURE 31 - perspective view of the second embodiment of the
30 vertical wind turbine equipped with fixtures. The aerodynamic panels are using the course limitation through cables. The arrows show the wind direction.

FIGURE 32 - perspective view of the third embodiment of the vertical wind turbine.

FIGURE 33 - front view of the third embodiment of the vertical wind turbine with the final course of the aerodynamic panels limited through cables.

FIGURE 34 - superior view of the third embodiment of the vertical wind turbine with the energy generation made by a generator placed at the top of the central post.

FIGURE 35 - cut front view of the third embodiment of the vertical wind turbine demonstrating the internal structure of the central post, the rotary structure and the rotary axis.

FIGURE 36 - superior view of the third embodiment of the vertical wind turbine with the energy generation made by a generator placed at the base of the central post powered by the rotary axis which transmits the rotation to a generator through a multiplier box.

FIGURE 37 - detailed perspective view of the third embodiment of the vertical wind turbine with the energy generation made by a generator placed at the top of the central post.

FIGUREA 38 - superior view of the third embodiment of the vertical wind turbine with the final course of the panels limited by the backstops system.

FIGURE 39 - cut front view of the third embodiment of the vertical wind turbine demonstrating the internal structure of the central post, the rotary structure and the generator.

FIGURE 40 - detail and cut superior view of the third embodiment of the vertical wind turbine. It is shown the rotary structure, the central post, the wheels and the horizontal arms of the aerodynamic panels.

- FIGURE 41** - perspective view of the fourth embodiment of the vertical wind turbine with the energy generation made by a generator placed at the base of the central post and the final course of the panels limited by the backstops system.
- 5 **FIGURE 42** - front view of the fourth embodiment of the vertical wind turbine with the energy generation made by a generator placed at the base of the central post and the final course of the panels limited by the backstops system.
- FIGURE 43** - superior view of the fourth embodiment of the vertical wind turbine with the energy generation made by a generator placed at the base of the central post and the final course of the panels limited by the backstops system.
- 10 **FIGURE 44** - perspective view of the fourth embodiment of the vertical wind turbine with the energy generation made by a generator placed at the base of the central post and the final course of the panels limited by the cables system.
- 15 **FIGURE 45** - front view of the fourth embodiment of the vertical wind turbine with the energy generation made by a generator placed at the base of the central post and the final course of the panels limited by the cables system.
- 20 **FIGURE 46** - superior view of the fourth embodiment of the vertical wind turbine with the energy generation made by a generator placed at the base of the central post and the final course of the panels limited by the cables system.
- 25 **FIGURE 47** - detailed perspective view of the mobile structure of the fourth embodiment of the vertical wind turbine with the energy generation made by a generator placed at the base of the central post and the final course of the panels limited by the backstops or cables system.
- 30 **FIGURE 48** - front view of the mobile structure of the fourth embodiment of the vertical wind turbine with the energy generation made by a generator placed at the base of the

central post and the final course of the panels limited by the backstops or cables system.

FIGURE 49 - superior view of the mobile structure of the fourth embodiment of the vertical wind turbine with the energy generation made by a generator placed at the base of the central post and the final course of the panels limited by the backstops or cables system.

FIGURE 50 - section view of the tower of the fifth embodiment of the vertical wind turbine with the power generation concentrated at the base of the tower and the final course of the panels limited by the backstops system.

FIGURE 51 - section view of the tower of the fifth embodiment of the vertical wind turbine with the power generation concentrated at the base of the tower and the final course of the panels limited by the cables system.

FIGURE 52 - superior view of the tower of the fifth embodiment of the vertical wind turbine in the D-D cut in figure 50, with the power generation concentrated at the base of the tower.

FIGURE 53 - detail view of the wheels system of the mobile metal structure of the tower of the fifth embodiment of the vertical wind turbine.

DETAILED DESCRIPTION OF THE INVENTION

For a better understanding of the present invention will be described below five possible ways of implementing or embodiments, however, the invention is not limited to the drawings and the embodiments below.

All embodiments have as a common element the aerodynamic panels system (1) with two symmetric boards, a top one (2) and other bottom (3), with interconnected movement by gears (4) that allow a synchronous movement between the blades (2) and (3). The Figures 01 to 13

illustrate the aerodynamic panels (1) and their variations of limiting of the course movement of the plates.

Figures 01A to 01C, 02A to 02C and 03A to 03C show the aerodynamic panel (1) elements and its movement dynamics and how it is fixed to an axis or a horizontal arm (5).

In the Figure 01C the aerodynamic panels (1) are receiving the wind in its front face and, with this, the blades (2) and (3) shall be in a vertical position. In this case the blades (2) and (3) are supported in the backstops (6) that limit the end of the course of the blades (2) and (3). The arrow indicates the direction of the wind.

In this position the aerodynamic panels (1) pushed by the wind force drive the vertical wind turbine around its vertical axis. The side of the turbine where the panels are in the open position is called as the active side or traction side.

In the Figure 01A the aerodynamic panels (1) are receiving the wind in their back face and, with this, the blades (2) and (3) shall be in the horizontal position or flattened. In this case the blades (2) and (3) are fully closed avoiding create drag or resistance for the wind. The arrow indicates the direction of the wind.

In this position the aerodynamic panels (1), closed by the wind force, remain horizontally until they back to the position to receive at least one wind force component on their front face. The side of the turbine, where the panels are in the closed position, is called as inactive side or drag side.

The Figures 04A to 04C, 05A to 05C and 06A to 06C also demonstrate the elements of the aerodynamic panel (1) and its movement dynamics and how it is fixed to an axis or a horizontal arm (5), however, in this configuration the movement restrictions of the blades is done through cables (7) that are set at the ends of the upper blades (2) and

bottom blades (3) and pass through a pulley at the end of the axis (8).

The Figures 07, 08 and 09 show in detail the aerodynamic panel. The blades (2) and (3) are with their
5 movements synchronized through the gears (4). Although it not illustrated in the figures, the gears can be involved by an oil box so as to improve the sync between the gears (4) and cancel the noise generated by the contact between the gears (4).

10 The gears (4) are linked to the parallel axis (9) and (10) of the superior blades (2) and bottom blades (3) respectively. The blades are also linked to these two axis (9) and (10) through securing tabs (11).

At the ends of the axis (9) and (10) are placed
15 bearings (12) responsible by the free rotation of the blades (2) and (3). These bearings are accommodated in the sidebars (13).

The sidebars (13) have the function to include and support the bearings (12) as well as fix the blades (2) and
20 (3) of the aerodynamic panel (1) on the shaft or horizontal arm (5).

Between the axis (9) and (10) leave the axis (8) by where the movement limiting cables (7) of the blades (2) pass.

25 On the right side of the blades (2) and (3) there is a tab (14) responsible by preventing that, when the blades are closed, a wind entering laterally into the aerodynamic panel be capable to open the blades and create a drag on the inactive rotation side or drag of the turbine, which would
30 reduce or cancel the turbine efficiency.

The Figures 10A, 10B and 10C illustrate the details from the axis (8) end where a pulley (15) is responsible by leave the cables (7) move freely tracking the movement of the blades (2) and (3).

Optionally the upper blade (2) and bottom blade (3) can be equipped with holes (16) that open and close by the sliding movement of a plate (17) that has the same holes (16) that the blades (2) and (3), and when the plate (17) is in the correct position, the holes (16) of the plate (17) coincide with the holes of the blades (2) and (3) allowing that increase or decrease the wind force catchment area and the possible control of the speed of the turbine depending on the variation of wind force.

10 The plates (17) are powered by servomotors (18) that are controlled by a control unit that controls the entire turbine. The movement of the plates (17) is guided by rails (19) in "L" format.

FIRST EMBODIMENT

15 In the smallest embodiment, illustrated in the figures 14 to 20, is provided a small system with a tubular axis (20) of small caliber to be fixed at the top of a mast or post (21). On this axis rotates a hollow cylindrical cover (22) through bearings (23) and (24) provided with at least one level of crosses (25), where each cross has four metal axis or arms (5) with 90° between them in which shall be fixed at least one aerodynamic panel (1) for each axis or arm.

25 The hollow cylindrical cover (22) occupies an extension equivalent to two thirds of the size of the tubular axis (20) and has on its basis a pulley (26) that will operate a small generator (27) that is set on the tubular axis (20) just below of the hollow cylindrical cover (22).

30 Optionally, the blades (2) and (3) may contain in its vertex of the open angle (meeting point between the two blades) a canvas or rubber flexible cover (28) in order to reduce the fugue of the wind through its rotating fixing horizontal axis (9) and (10).

The figures 14 to 16 demonstrate this first embodiment with the movement limiting system of the blades (2) and (3) of the panels (1) by backstops (6) and the figures 17 to 19 demonstrate this first embodiment with the movement limiting system of the blades (2) and (3) of the panels (1) by cables (7).

SECOND EMBODIMENT

Also, in this small version, as illustrated in the figures 21 to 31, it may be presented with a different configuration in which the tubular axis (20), on which rotates the hollow cylindrical cover (22) with the sustaining axis or arms (5) and the panels (1) to capture the wind force, down almost until the floor exercising the function of a hollow mast fixed in a cabinet (29) of small height fixed to the ground and scaled with enough internal space to receive not only the tip of the spin axis (30) but also a rotation multiplier box (31), a generator (32), a battery (33) and a voltage converter (34) where

The spin axis (30) goes down inside the sustaining tubular axis (20) of the hollow cylindrical cover (22) and it is coupled by an elastic gasket (35) to the rotation multiplier box (31) that is coupled to a generator (32).

The battery (33) and the voltage converter (34) can be used in regions where the winds stop sometimes.

In this configuration the hollow cylindrical cover (22) does not have the external pulley (26), since the transmission of the rotation is done inside the post, and it can optionally receive arms with fixtures or luminaires (36).

This embodiment can be used to power small consumers and one or more lighting posts with a prior study of desired power for the scale of the size and the quantity of panels to the wind force capture as well as the appropriate generation set for the local necessity.

Optionally, instead the axis is down inside the mast or post, the hollow cylindrical cover (22) can down until the base provided with a ratchet to move the rotation multiplier box (31).

5 **THIRD EMBODIMENT**

In larger embodiments, as illustrated in figures 32 to 40, for medium and large potencies the system is mounted on a metal or concrete tower (37).

In this case, the hollow cylindrical cover will not be used. Instead this, a rotating metal structure (38) that comprises the turbine will be used.

On the top of the tower can be provided, as a first option, an aerogenerator (39) vertically fixed in the concrete or metal structure with its axis (40) facing up on which will be seated the rotating turbine built in metal structure having in its top level (41) the four axis or arms (5) with 90° between them that will be provided with one or more aerodynamic traction panels (1), already described above, in each axis or arm (5).

From the top of the turbine, that receive the arms of the top-level, down multiple metallic structural elements or columns (42) around the tower to form a new set of four arms, a second lower level, containing the wind force capture aerodynamic panels (1) forming an angle of 90° between themselves and 45° with the projection of the arms of the higher level.

This metallic structure is exclusively set to the spin axis of the aerogenerator, however, exist in the lower-level a caster or wheels system (43) that slide on the circular tower (37) to increase the stability of the structure.

Also there are casters or wheels (43) in metallic elements between the top and bottom levels so that the

structure of the turbine does not suffer undue oscillatory movements.

FOURTH EMBODIMENT

As a second option to the third embodiment, as illustrated in figures 41 to 49, the same system described above can be used, but, instead of the aerogenerator (39) be set at the top of the tower (37), an metal axis (44) seated on bearings (46) is placed, with the same proportions to receive the turbine and transmit this rotation until the base of the tower by an axis (44), that downs internally connecting to a rotating converter (47) fixed to the floor that will receive a medium or large generator.

This axis (44), in this long down trajectory, is formed by several elements interconnected by elastic gaskets (45).

The height of the tower and the size of the panels and the number of levels of panels will depend of the desired power.

FIFTH EMBODIMENT

For mega embodiments with large scale power generation, in which a single wind turbine tower may replace 30 or more helix aerogenerators of the state of the art, it is introduced a configuration in which a metallic mega structure rotates on a reinforced concrete mega structure and that uses the same aerodynamic panels model described above.

The mega structure provides two power generation options.

The first one, as illustrated in figures 50 to 53, concentrates the whole generation in a large machines room that receives the sum of the entire torque force produced in all aerodynamic panels levels.

The second option, instead of unify the force of all levels into a single point of power reception to the

generators, divides the power generation in levels or aerodynamic panels levels sets that work independently from each one unit of power generation.

Both options use the same system, that is composed by a
5 mega structure in reinforced concrete be provided with pillars (48) forming circles interconnected by reinforced concrete circular platforms (49) as if it were disks with much bigger diameter compared to the circle formed by the pillars in order to receive in the borders of these
10 platforms (49) the sliding materials, i.e., wheels (52) and (53) which will support the vertical elements or mobile pillars (50) interconnected each other by metal beams (51) forming a rigid set that, from a certain height, will receive the big scale arms (5) that will contain various
15 aerodynamic traction panels already described previously.

In the first power generation option, in only one large machines room, that receives the sum of all the torque force produced by all aerodynamic panels levels, the rotational structure is linked from the top until the bottom through
20 vertical elements (50) and horizontal structural elements (51) to transmit the sum of the rotational force of all levels so that, from the last level that contains wind force catch panels, the sum of these vertical elements (50) fixed to each other form a huge pipe down until the power
25 generation room in the first high level where they are connected to a huge ratchet with several meters in diameter seated on sliding rotating elements and immersed in lubricating oil which will move diverse rotation converters and coupled generators.

30 The huge pipe formed by the vertical elements (50), from the last level of panels, down until the generation room, located on the first level of the concrete structure, once, in this configuration, are only used catch panels with more than 100m of height, and also has several levels of

superior (52) and lateral (53) rotary elements of support in the circular concrete platforms (49) so that to avoid that the whole rotating descent structure overload the sliding elements of the higher levels from the wind force catch panels levels promoting better load distribution and reduced oscillation of the rotating metal structure on the concrete structure.

On the ground level of the concrete tower have the access to the elevator, to the stairways and to the two ramps for the access of the trucks to the top level.

The top level has a coverage concrete slab of the machines room with a hole by where pass the rotating tubular structure formed by vertical elements. At this level there is no access to the stairs and to the elevator due to the large rotating tubular structure.

The concrete tower has its first two levels consisting by a rectangular or square building followed up to the top by a circular tower and in its top is provided with a beam of reinforced concrete with the same width of the diameter formed by the rotating arms, provided with a mono rail on its lower surface with hooks to the fixation cables to scaffolding to the assembly and maintenance of the metal structure.

In the second power generation option, the vertical metal elements shall transmit the force, i.e., in each two levels of panels in an independent way.

On each two levels of panels, in one of these platforms of these levels, are fixed to the mobile vertical pillars a ratchet which moves a rotating converter attached to a generator, fixed on the concrete platform, and so forth.

Thus, from the last level of wind force catch panels until the ground there are no more the descent vertical structure and so only the concrete tower, which also does

not have the first generation room level of the previous configuration.

The cables of the generators down through a duct until the ground where is installed a control and electronic
5 supervision room of the entire turbine.

CLAIMS

1. VERTICAL WIND TURBINE characterized by have aerodynamic panels (1) which consist of two aerodynamic blades (2) and (3) with synchronized and interconnected movement through gears (4) and that open simultaneously and symmetrically one upwards and the other downwards by the action of the frontal wind and that close simultaneously and symmetrically from bottom to top and top to bottom, by the action of the wind at your back encountering each other as if they were a single aerodynamic horizontal surface, and the aerodynamic panels (1) are fixed to the axes or arms (5) of the crosses (25) which rotate on an axis or vertical structure.
2. VERTICAL WIND TURBINE according to claim 1, characterized by the blades (2) and (3) of the aerodynamic panels (1) are, each one, fixed to a superior horizontal axis (9) and lower horizontal axis (10) respectively through securing tabs (11), and with bearings (12) on the axis ends housed in the sidebars (13).
3. VERTICAL WIND TURBINE according to claim 1, characterized by the blades (2) and (3) of the aerodynamic panels (1) be fixed to horizontal axis or arm (5) through the sidebars (13).
4. VERTICAL WIND TURBINE according to claim 1, characterized by the blades (2) and (3) of the aerodynamic panels (1) have an angulation on its borders both front, in the opposite side of the sustaining axis (5), as lateral, tabs (14), so as to allow them to open as soon as enter in the traction cycle and close when enter in the flat cycle to obtain the full use of the wind force in the 180° of the traction cycle and in the 180° of the inactive cycle.

5. VERTICAL WIND TURBINE according to claim 1, characterized by the blades (2) and (3) of the aerodynamic panels (1) contain, in the centre of its extremities, opposite to the horizontal axes, electromagnetic coils that are energized by a supervision and control system to maintain the blades horizontally or flatted regardless of the wind direction in order to prevent situations of storm or even to stop the turbine for maintenance.
6. VERTICAL WIND TURBINE according to claim 1, characterized by the blades (2) and (3) of the aerodynamic panels (1) contain, in its vertex aperture angle (meeting point between the two blades), a canvas or rubber flexible jacket in order to reduce the wind escape through its rotating fixing horizontal axis.
7. VERTICAL WIND TURBINE according to claim 1, characterized by each axis or arm (5) have at least one aerodynamic traction panel (1).
8. VERTICAL WIND TURBINE according to claim 1, characterized by the upper blade (2) moves in a 1/4 circle course from the horizontal position to upwards and the inferior blade (3) moves in a 1/4 circle course from the horizontal position to down symmetrically with the upper blade (2).
9. VERTICAL WIND TURBINE according to claim 1, characterized by the blades (2) and (3) of the aerodynamic panels (1) be exclusively moved by the action of the wind and doesn't have any mechanical system of interdependence between the panels in the same arm or between panels from the traction side and the inactive side or horizontally side.
10. VERTICAL WIND TURBINE according to claim 1, characterized by the blades (2) and (3) of the aerodynamic panels (1) both to open as to be closed independent of their mass (weight) and material that are constructed, because they have always zero weight in

relation to the work of the wind force to open them or close them due also to the function as counter-weight of each panel blade, resulting in the maximum use of wind force practically with zero percent of loss of the buoyancy obtained in the traction side in relation to the inactive side (only the area equivalent to the attack edge of the inactive side flattened or closed will produce a despicable drag).

11. VERTICAL WIND TURBINE according to claim 1, characterized by the blades (2) and (3) of the aerodynamic panels (1) have a control of the wind catchment area in each one of the blades from a set of aerodynamic panels with the simple sliding of a second blade sliding over the other in both upper and lower plate symmetrically to slide through the command of a servo motor on each panel blade open or close roles growing and decreasing the wind catchment area of each panel blade aerodynamic enabling the speed control and the torque of the turbine in areas where the wind speed oscillates a lot.

12. VERTICAL WIND TURBINE according to claim 1, characterized by the blades (2) and (3) of the aerodynamic panels (1), when it opens symmetrically, due the work of the gears between them, with a counterweight effect, they became restricted almost in a vertical position through rubber stops fixed on bars attached to their arms to up and to down, or through elastic rope passing on a central axis that are between the panels with a pulley which gives passage rope which is fixed at the ends of the panels thus limiting the maximum opening, which also helps avoid noises when the blades reach its end of the course.

13. VERTICAL WIND TURBINE according to claim 1, characterized by the gears (4), of the blades (2) and (3)

of the aerodynamic panels (1), are involved by an oil box so as to improve the sync between the gears (4) and cancel the noise generated by the contact between the gears (4).

5 14. VERTICAL WIND TURBINE according to claim 1, characterized by can be configured to rotate clockwise or counterclockwise regardless of the wind direction.

15. VERTICAL WIND TURBINE according to claim 1, characterized by captures the wind force in any direction
10 not requiring equipment, sensors, windsock, engines, etc to redirect it to the wind direction.

16. VERTICAL WIND TURBINE according to claim 1, characterized by a first embodiment, with a tubular axis
15 (20) of small caliber to be fixed at the top of a mast or post (21), on this axis rotates a hollow cylindrical cover (22) through bearings (23) and (24) provided with at least one level of crosses (25), where each cross has four metal axis or arms (5) with 90° between them in which shall be fixed at least one aerodynamic panel (1) for
20 each axis or arm, said hollow cylindrical cover (22) occupies an extension equivalent to two thirds of the size of the tubular axis (20) and has on its basis a pulley (26) that will operate a small generator (27) that is set on the tubular axis (20) just below of the hollow
25 cylindrical cover (22), and the movement of the blades (2) and (3) of the panels (1) it is limited by backstops (6) or by cables (7).

17. VERTICAL WIND TURBINE according to claim 16, characterized by, in a second embodiment, the tubular
30 axis (20), on which rotates the hollow cylindrical cover (22) with the sustaining axis or arms (5) and the panels (1) to capture the wind force, down almost until the floor exercising the function of a hollow mast fixed in a cabinet (29) of small height fixed to the ground and

scaled with enough internal space to receive not only the tip of the spin axis (30) but also a rotation multiplier box (31), a generator (32), a battery (33) and a voltage converter (34) where the spin axis (30) downs inside the sustaining tubular axis (20) of the hollow cylindrical cover (22) and it is coupled by a elastic gasket (35) to the rotation multiplier box (31) that is coupled to a generator (32).

18. VERTICAL WIND TURBINE according to claim 17, characterized by the post (20) be equipped with fixtures or luminaires (36).

19. VERTICAL WIND TURBINE according to claim 16, characterized by the hollow cylindrical cover (22) is provided with a ratchet to move the rotation multiplier box (31).

20. VERTICAL WIND TURBINE according to claim 1, characterized by, in a third embodiment, a rotating metal structure (38) is mounted on the top of the tower, and, on the top of the tower (37), an aerogenerator (39) is vertically fixed in the concrete or metal structure with its axis (40) facing up on which will be seated the rotating turbine built in metal structure having in its top level (41) the four axis or arms (5) with 90° between them that will be provided with at least one aerodynamic traction panel (1) in each axis or arm (5), and from the top of the turbine, down multiple metallic structural elements or columns (42) around the tower to form a new set of four arms, and, a second lower level, containing the wind force capture aerodynamic panels (1) forming an angle of 90° between themselves and 45° with the projection of the arms of the higher level, and the rotary metallic structure (38) is exclusively set to the spin axis (40) of the aerogenerator (39), and, in the lower-level a caster or wheels system (43) that slide on

the circular tower (37) to increase the stability of the structure.

21. VERTICAL WIND TURBINE according to claim 1, characterized by, in a fourth embodiment, instead of the aerogenerator (39) be set at the top of the tower (37),
5 an metal axis (44) seated on bearings (46) is placed, with the same proportions to receive the turbine and transmit this rotation until the base of the tower by an axis (44), that downs internally connecting to a rotating
10 converter (47) fixed to the floor that will receive a medium or large generator.

22. VERTICAL WIND TURBINE according to claim 1, characterized by, in a fifth embodiment, a metallic mega structure rotates on a reinforced concrete mega structure
15 concentrating the whole generation in a large machines room that receives the sum of the entire torque force produced in all aerodynamic panels levels.

23. VERTICAL WIND TURBINE according to claim 22, characterized by, the mega structure in reinforced
20 concrete be provided with pillars (48) forming circles interconnected by reinforced concrete circular platforms (49) as if it were disks with much bigger diameter compared to the circle formed by the pillars in order to receive in the borders of these platforms (49) the
25 sliding materials, as wheels (52) and (53) which will support the vertical elements or mobile pillars (50) interconnected each other by metal beams (51) forming a rigid set that, from a certain height, receive the big scale arms (5) that contain various aerodynamic traction
30 panels (1).

24. VERTICAL WIND TURBINE according to claim 22, characterized by the rotational structure is linked from the top until the bottom through vertical elements (50) and horizontal structural elements (51) to transmit the

sum of the rotational force of all levels so that, from the last level that contains wind force catch panels, the sum of these vertical elements (50) fixed to each other form a huge pipe down until the power generation room in the first high level where they are connected to a huge ratchet with several meters in diameter seated on sliding rotating elements and immersed in lubricating oil which will move diverse rotation converters and coupled generators that are bound into a single large machines room that receives the sum of all the torque force produced by all levels of aerodynamic panels (1).

5
10
15
25. VERTICAL WIND TURBINE according to claim 22, characterized by, in the concrete tower, on the ground level, have access to the elevator, to the stairways and to the two ramps for the access of the trucks to the top level, and in the top level has a coverage concrete slab of the machines room with a hole by where pass the rotating tubular structure formed by vertical elements.

20
25
26. VERTICAL WIND TURBINE according to claim 22, characterized by, the top of the concrete tower is provided with a beam of reinforced concrete with the same width of the diameter formed by the rotating arms, provided with a mono rail on its lower surface with hooks to the fixation cables to scaffolding to the assembly and maintenance of the metal structure.

30
27. VERTICAL WIND TURBINE according to claim 1, characterized by, in a fifth embodiment, a metal mega structure rotates on a reinforced concrete mega structure with the energy generation distributed into levels or sets of aerodynamic panels levels that work independently from each force generation unit through the distribution of the generators in these levels.

28. VERTICAL WIND TURBINE according to claim 24, characterized by, the vertical metal elements transmit

the force, in each two levels of panels in an independent way to generators installed in these levels through ratchets which move rotating converters attached to a generators, fixed on the concrete platform, and cables of
5 the generators down through a duct until the ground where is installed a control and electronic supervision room of the entire turbine.

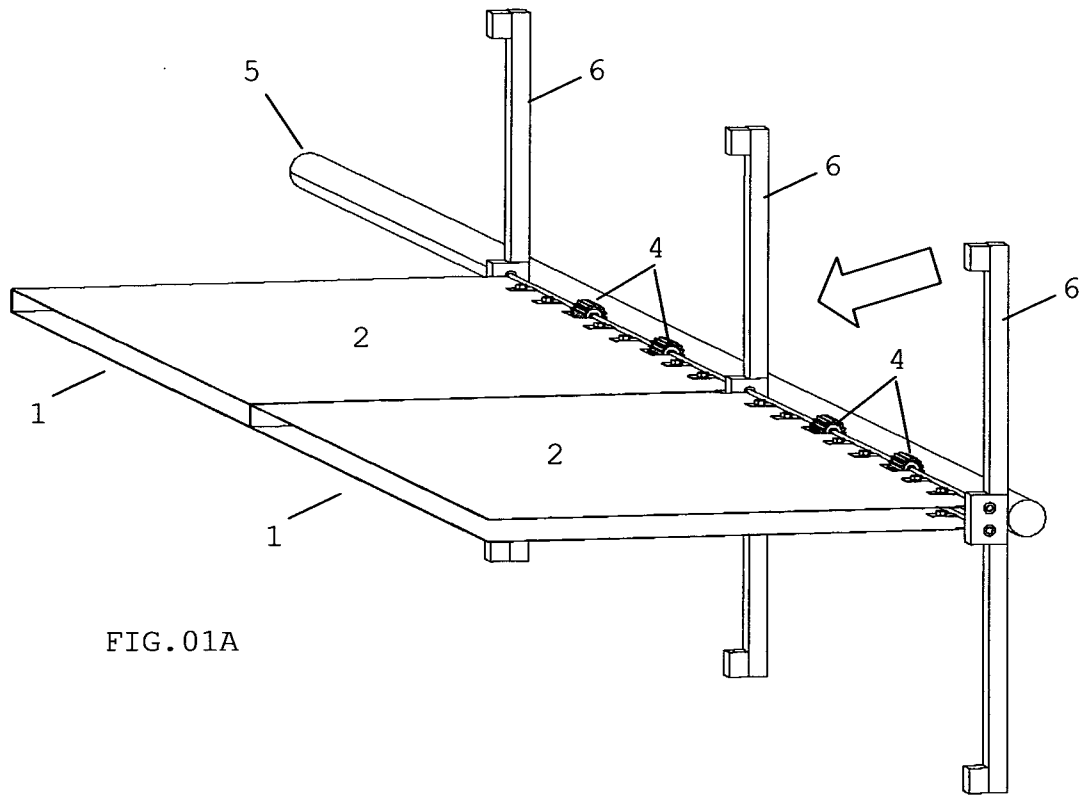

FIG. 01A

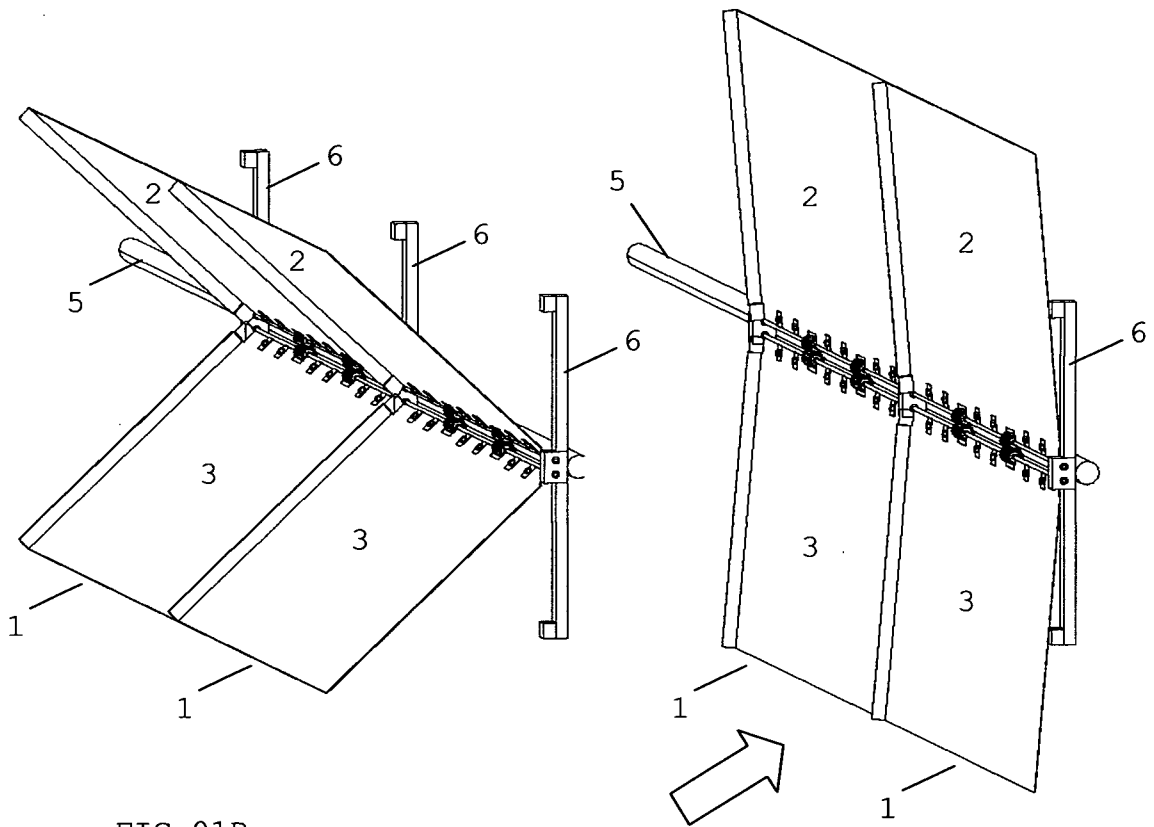
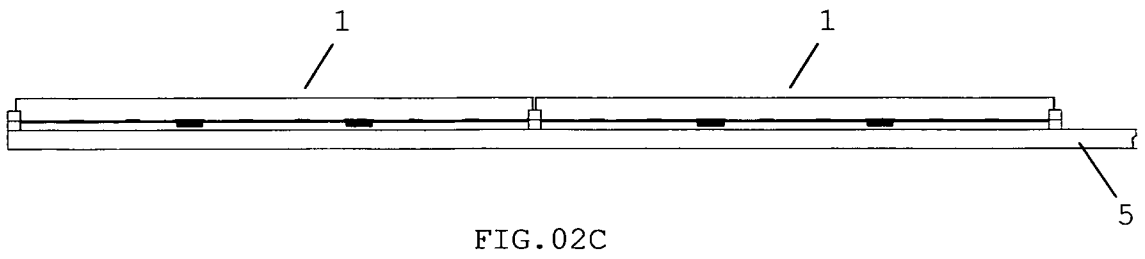
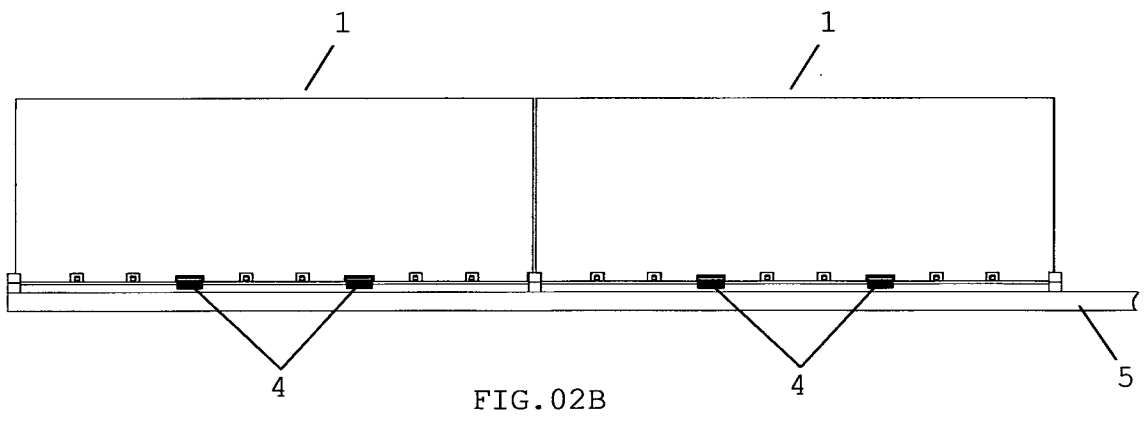
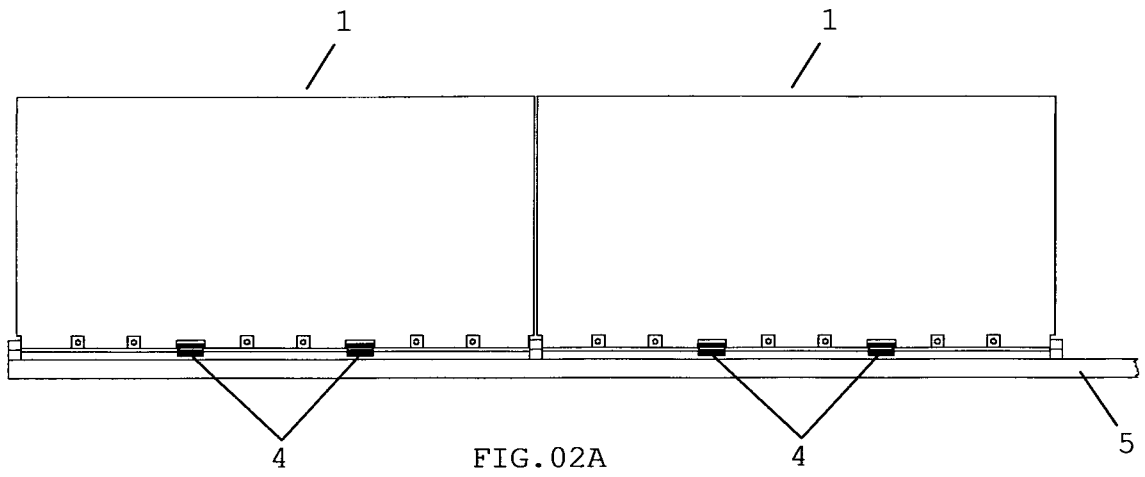

FIG. 01B

FIG. 01C



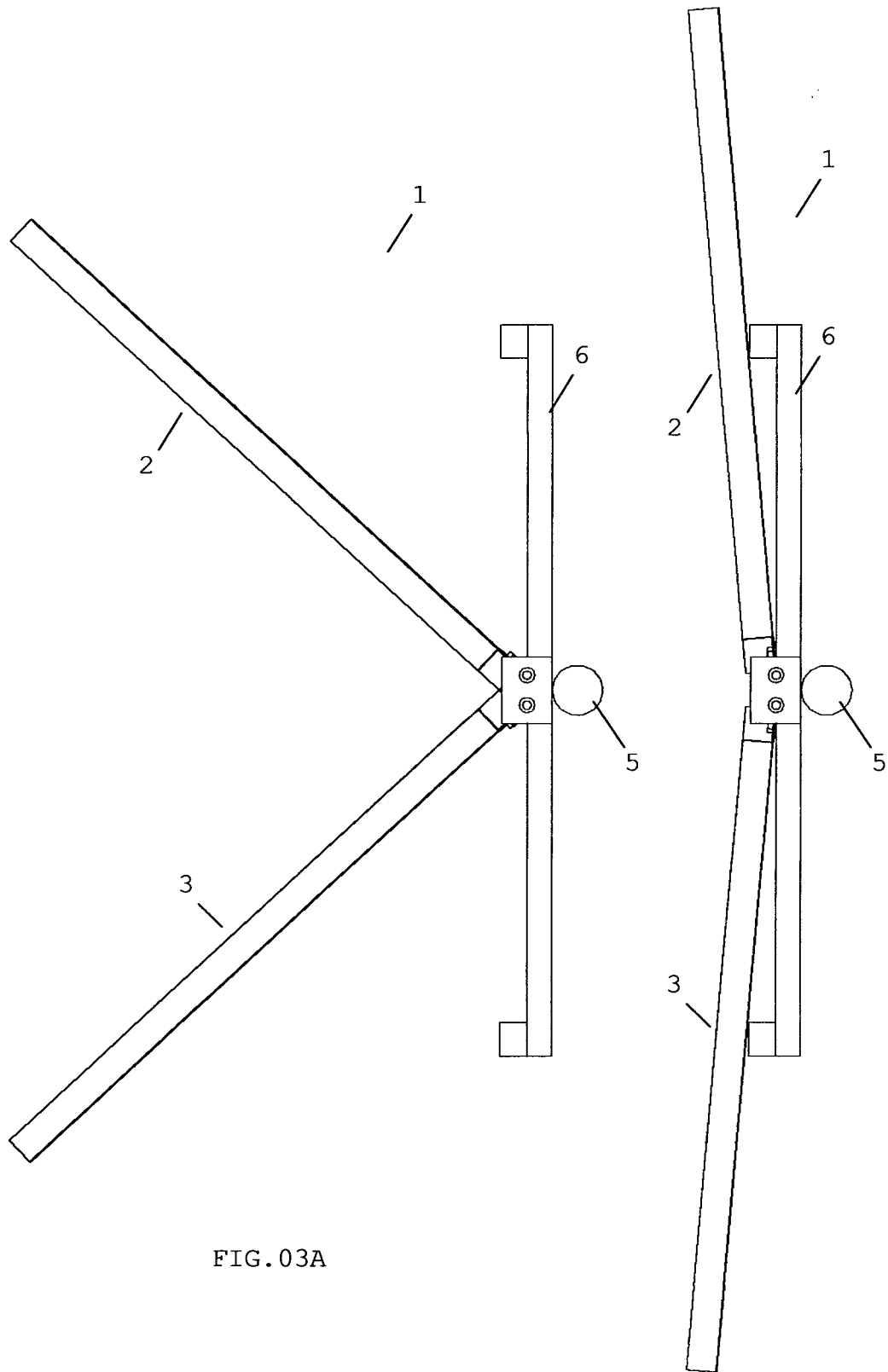

FIG. 03A

FIG. 03B

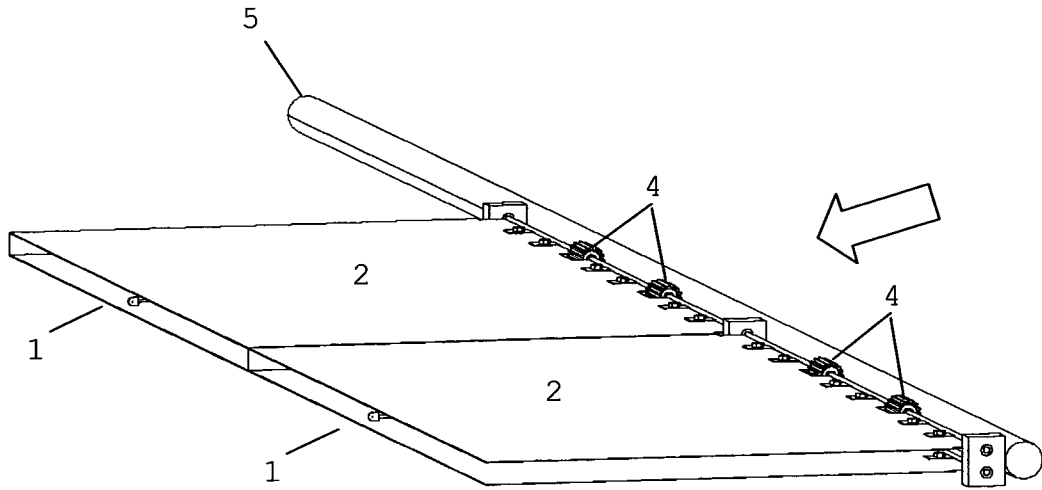

FIG. 04A

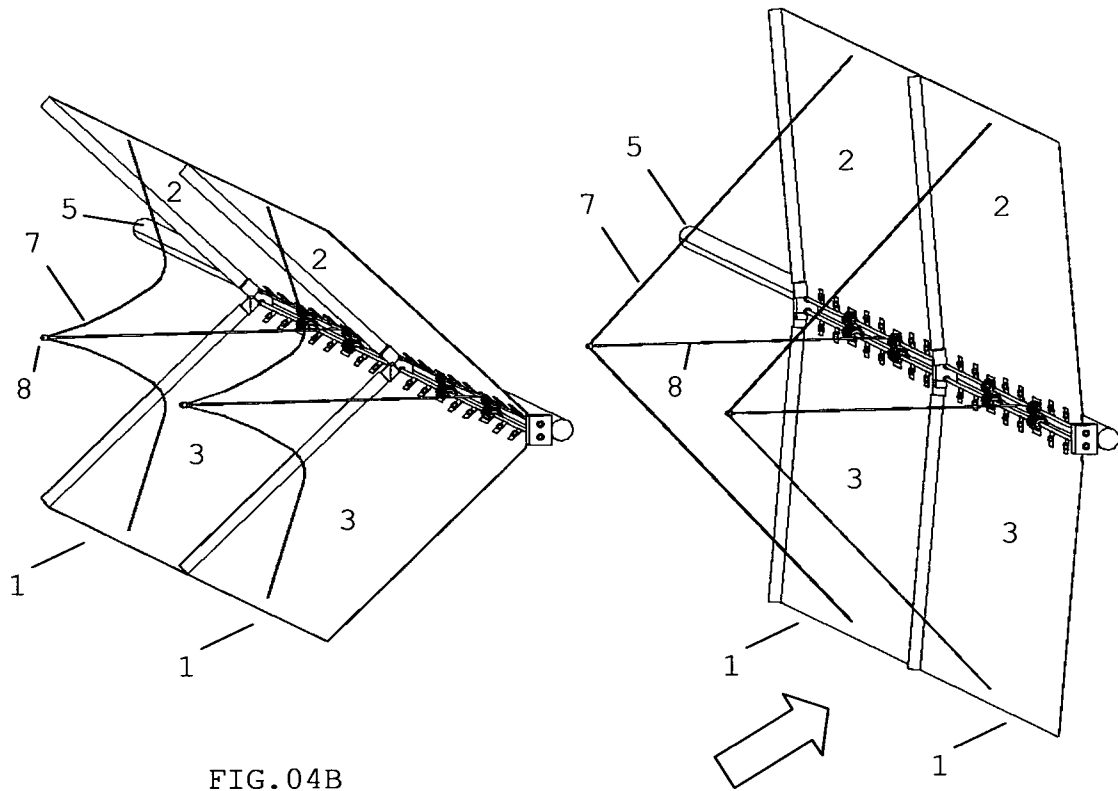

FIG. 04B

FIG. 04C

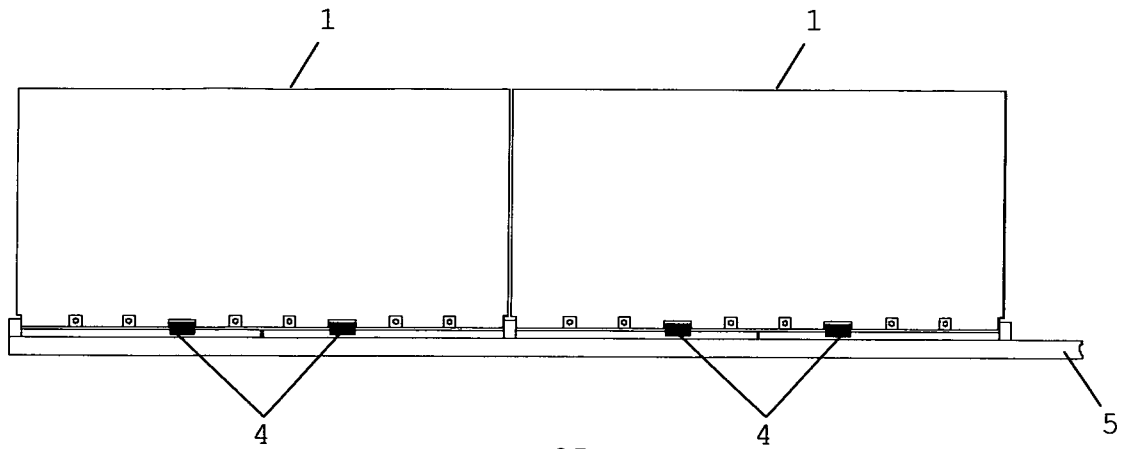

FIG. 05A

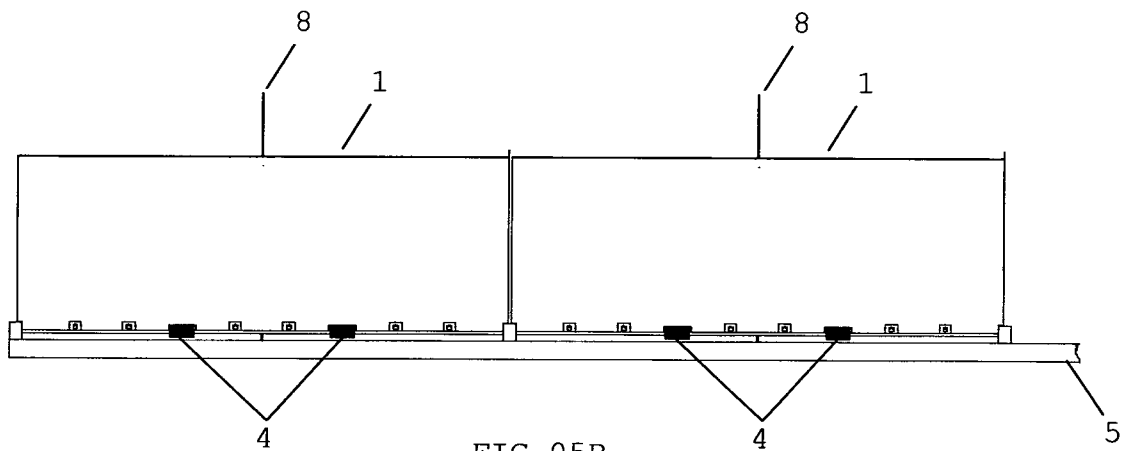

FIG. 05B

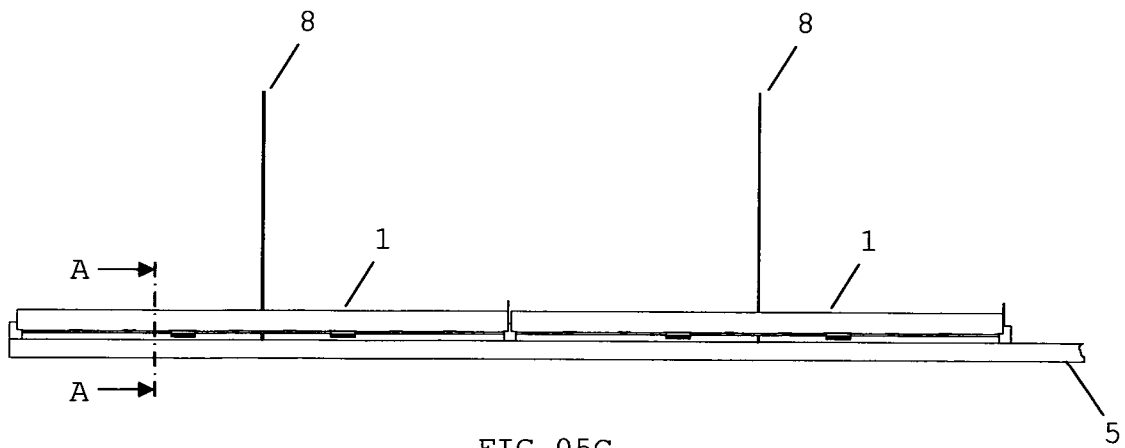

FIG. 05C

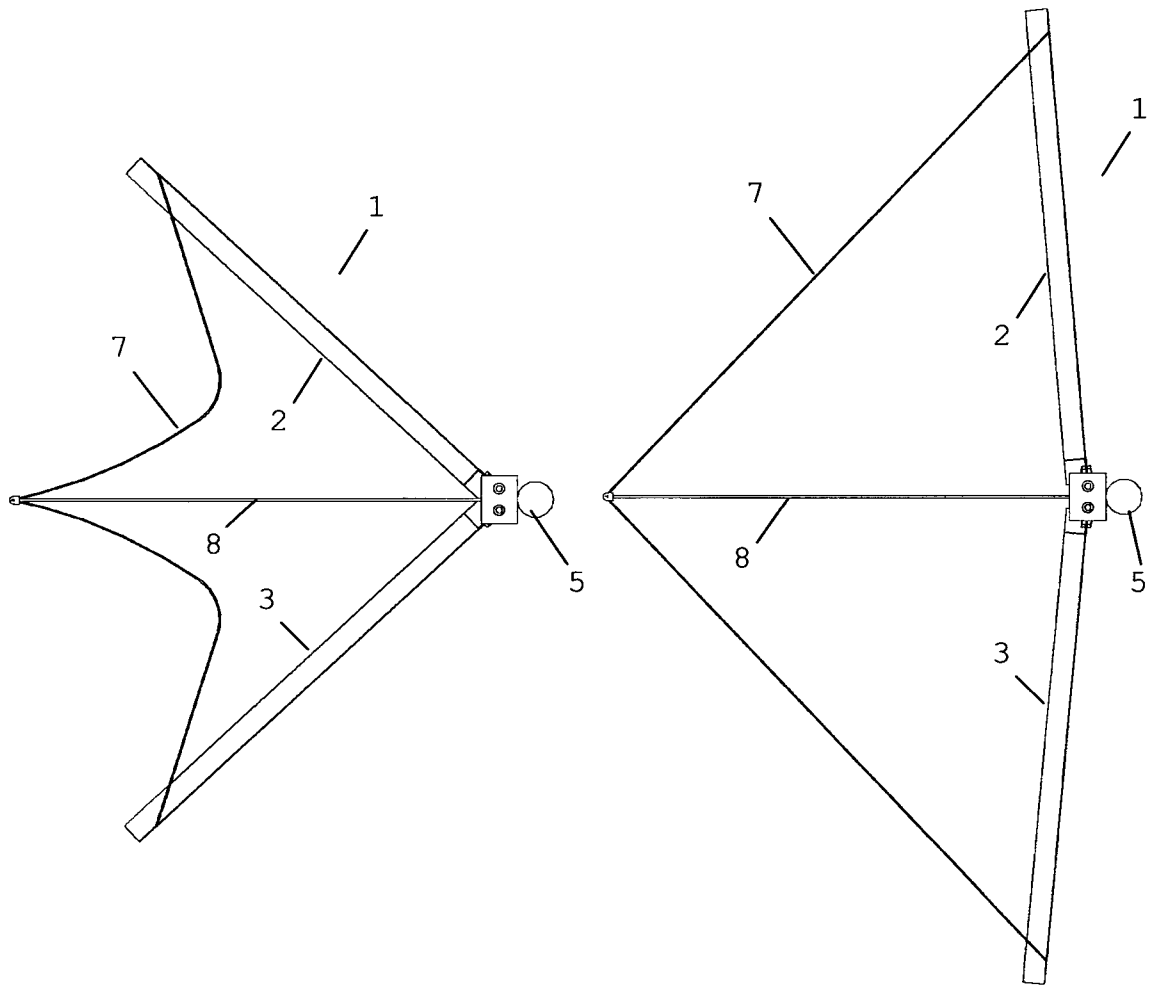

FIG. 06A

FIG. 06B

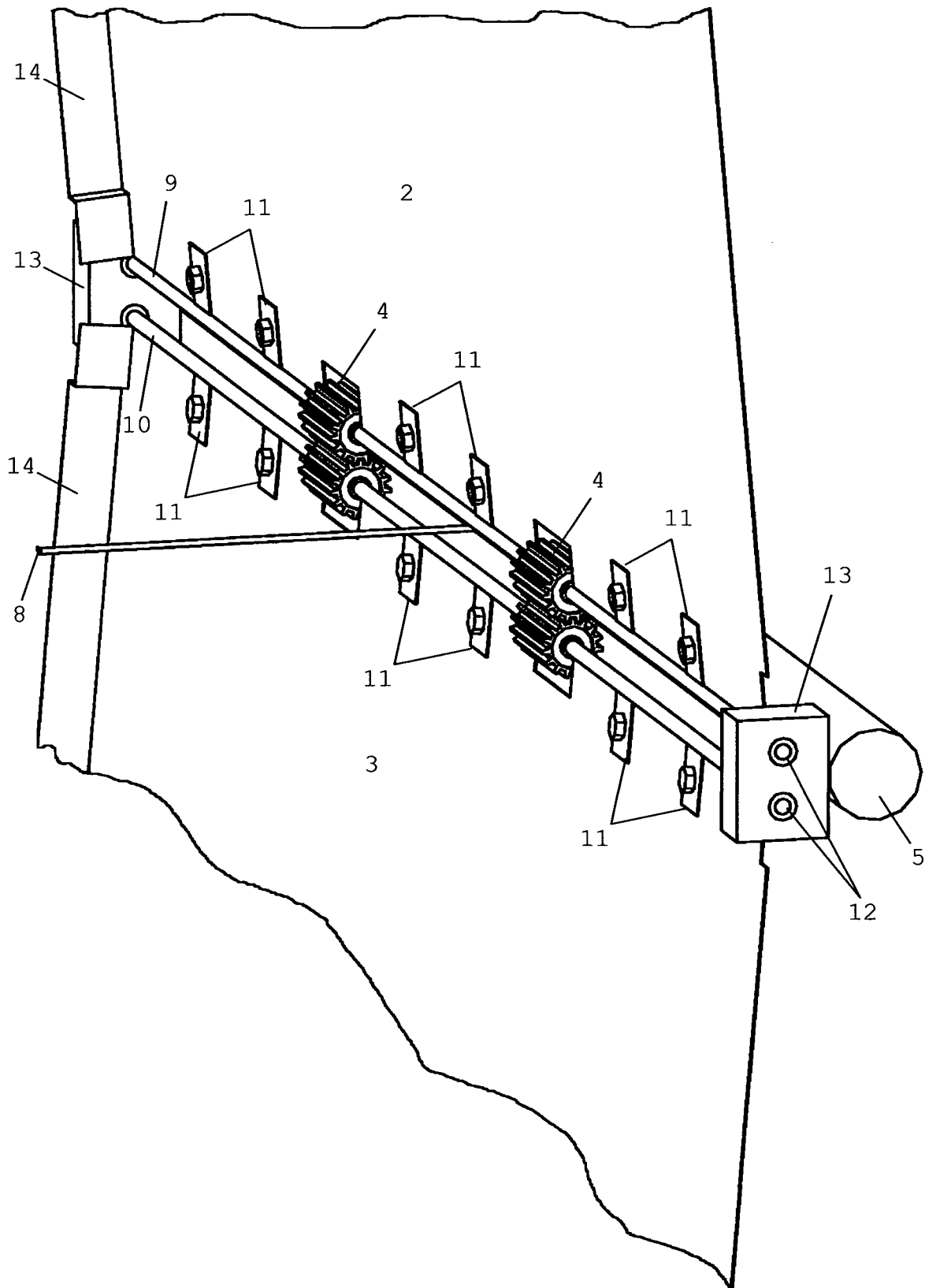

FIG. 07

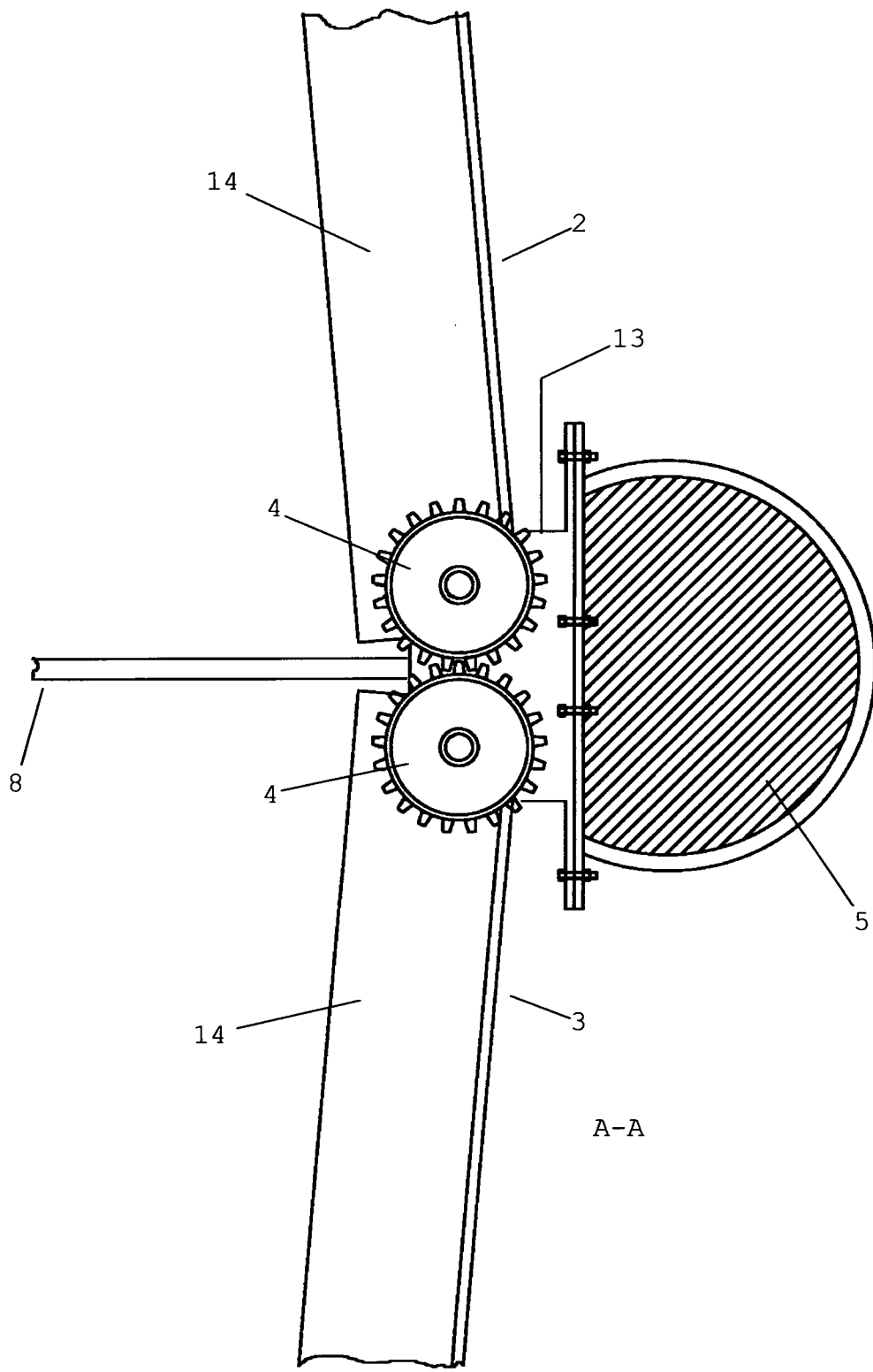

FIG. 08

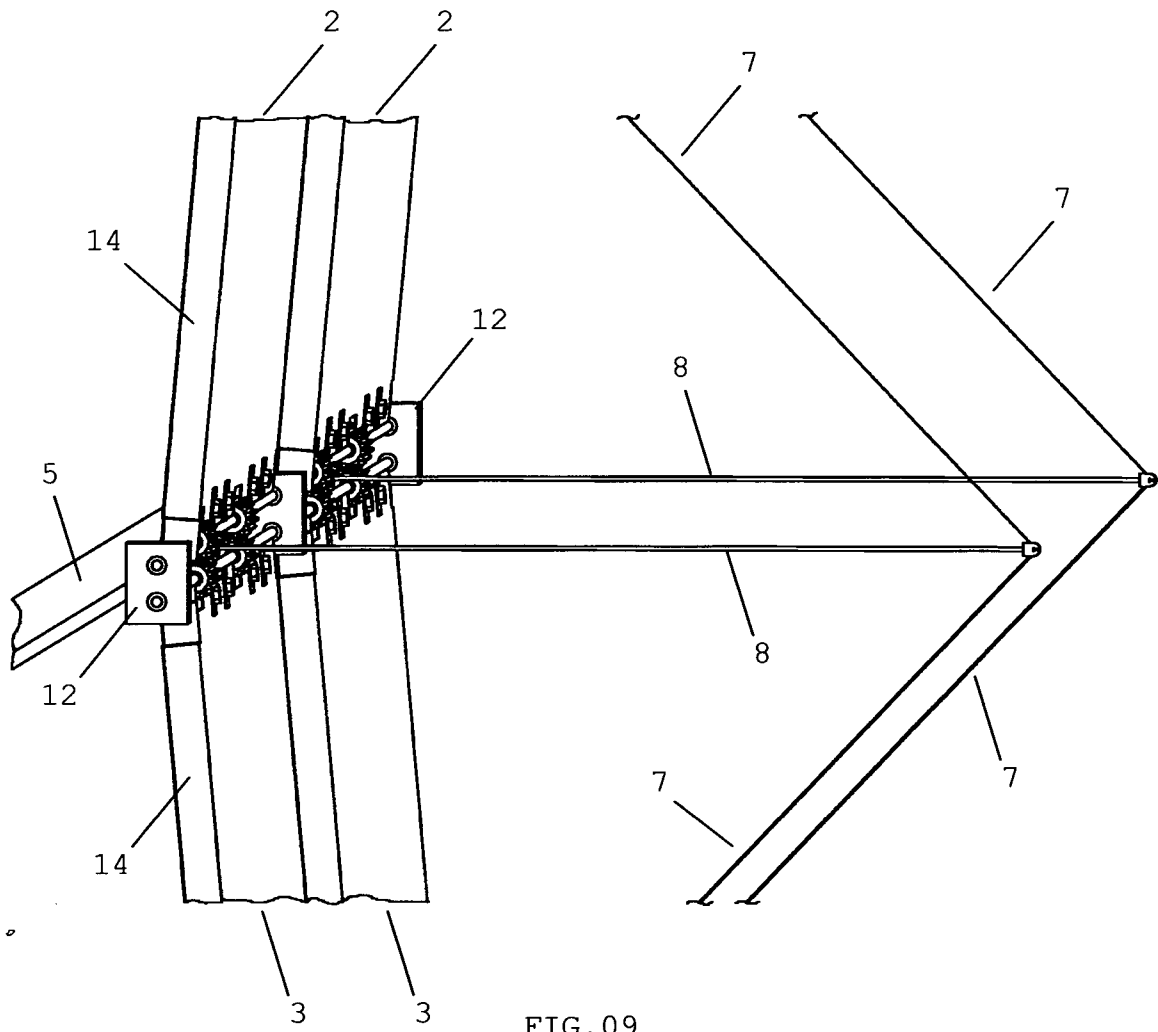

FIG. 09

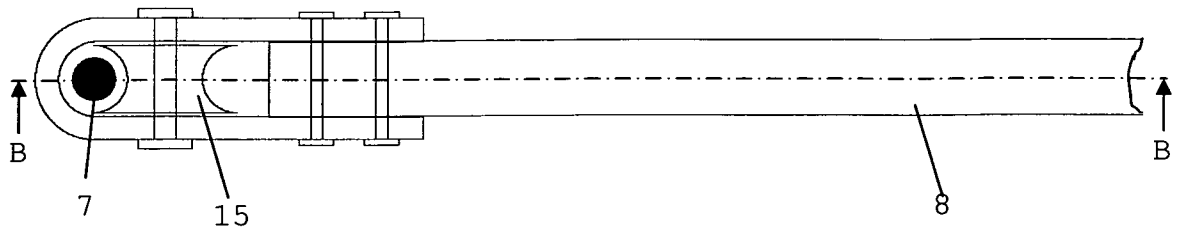

FIG. 10A

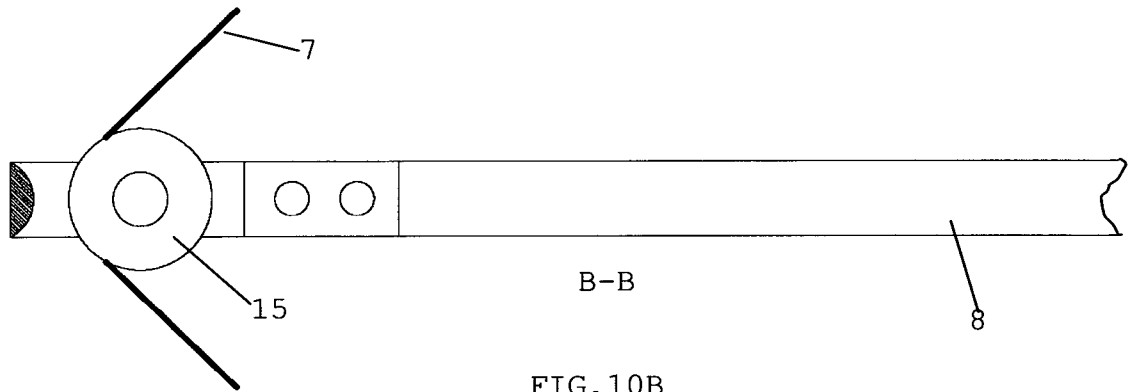

FIG. 10B

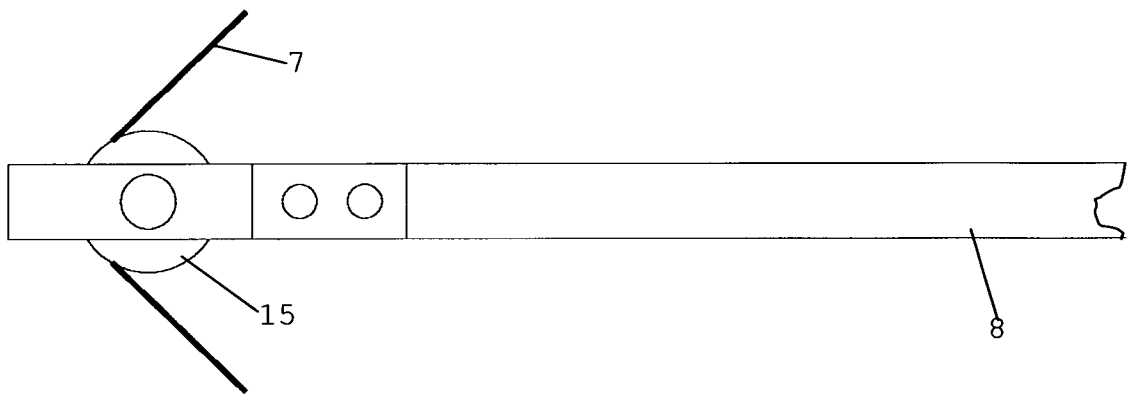

FIG. 10C

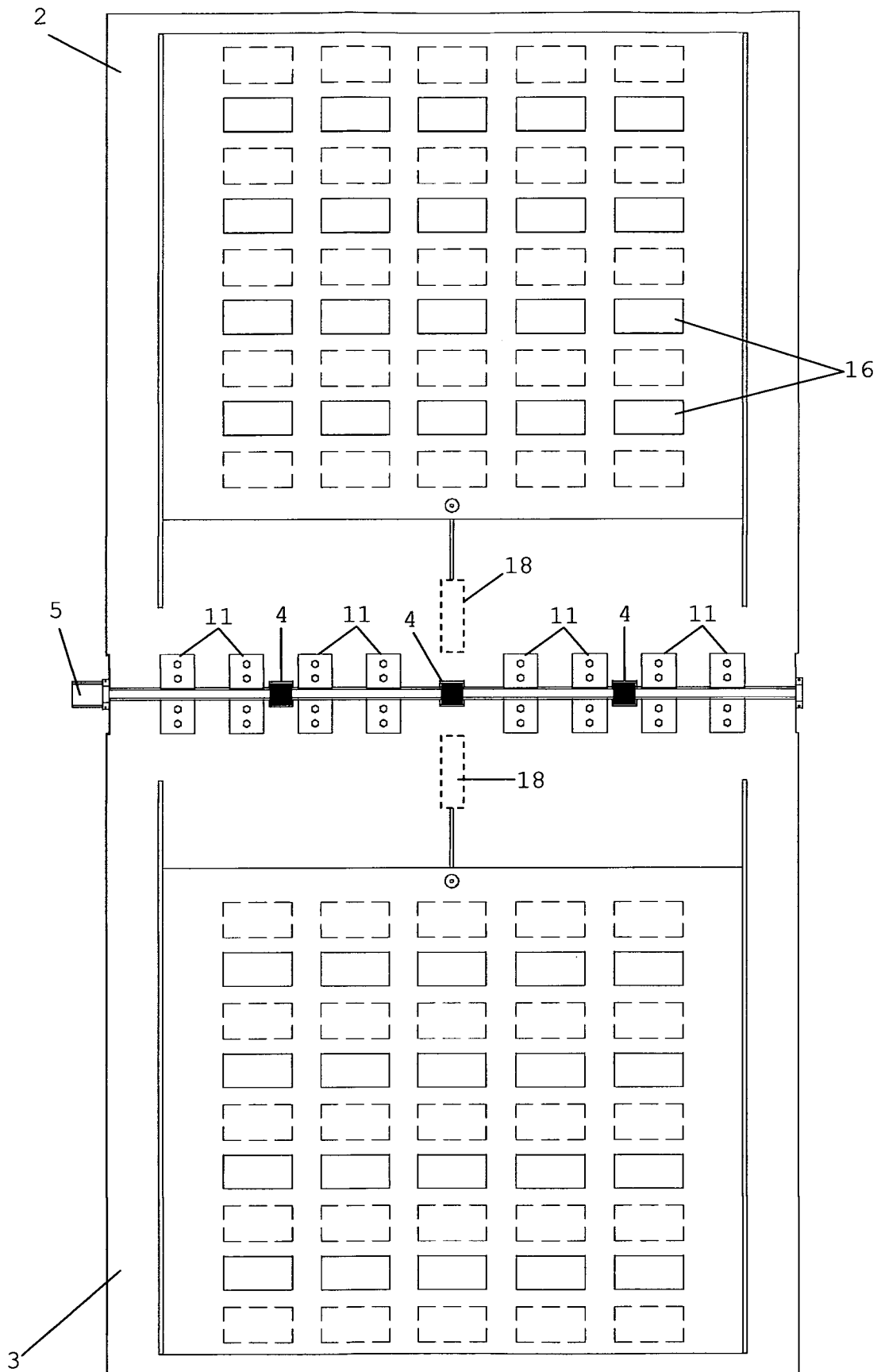

FIG. 11

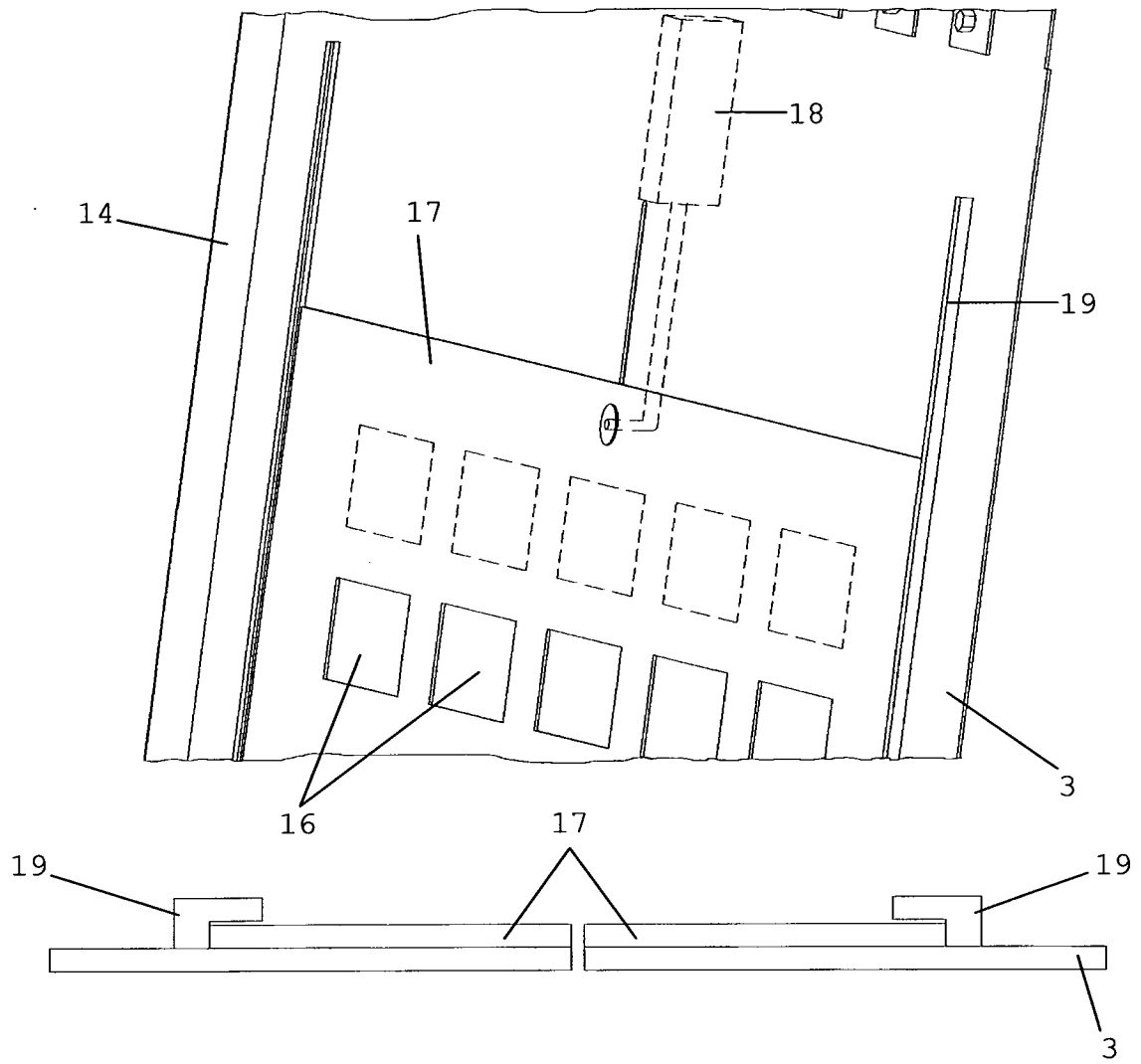

FIG. 12

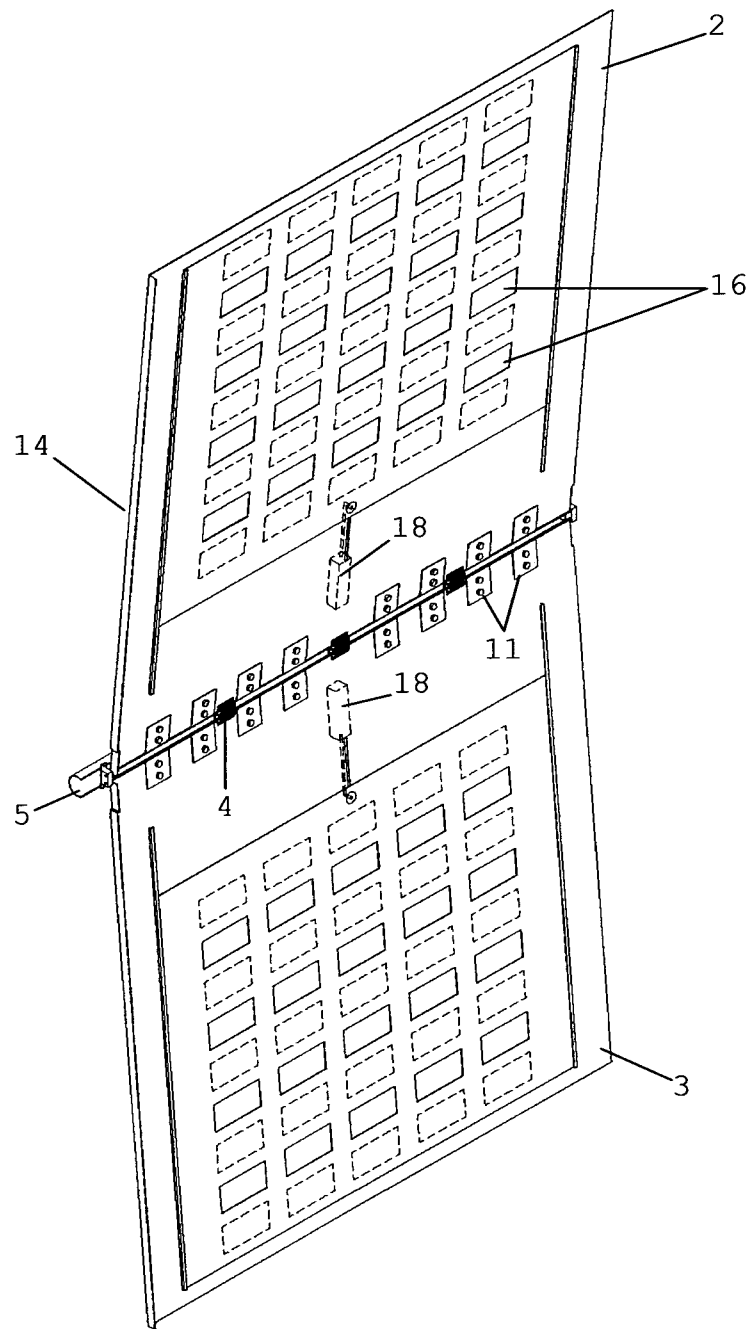

FIG. 13

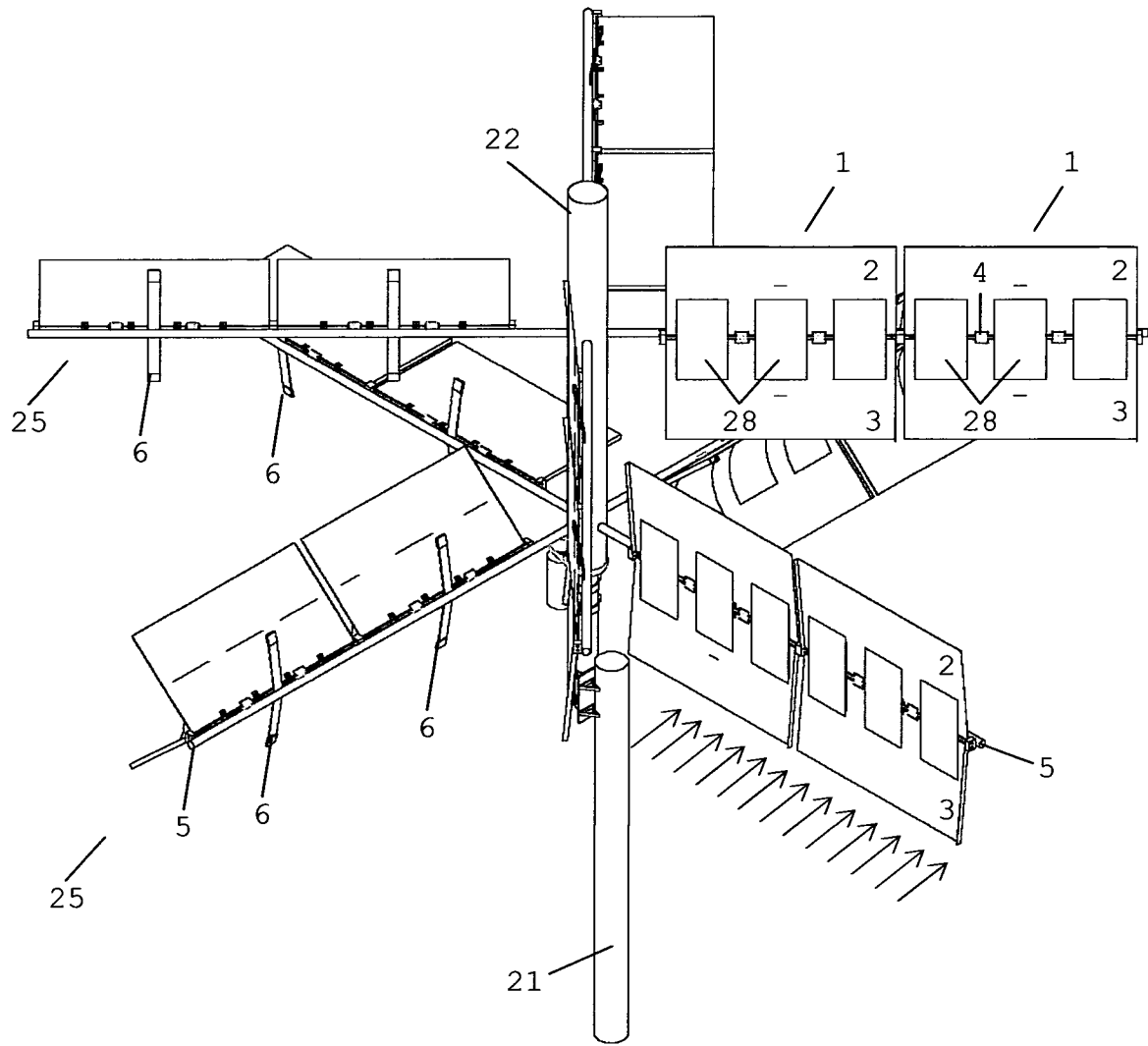

FIG. 14

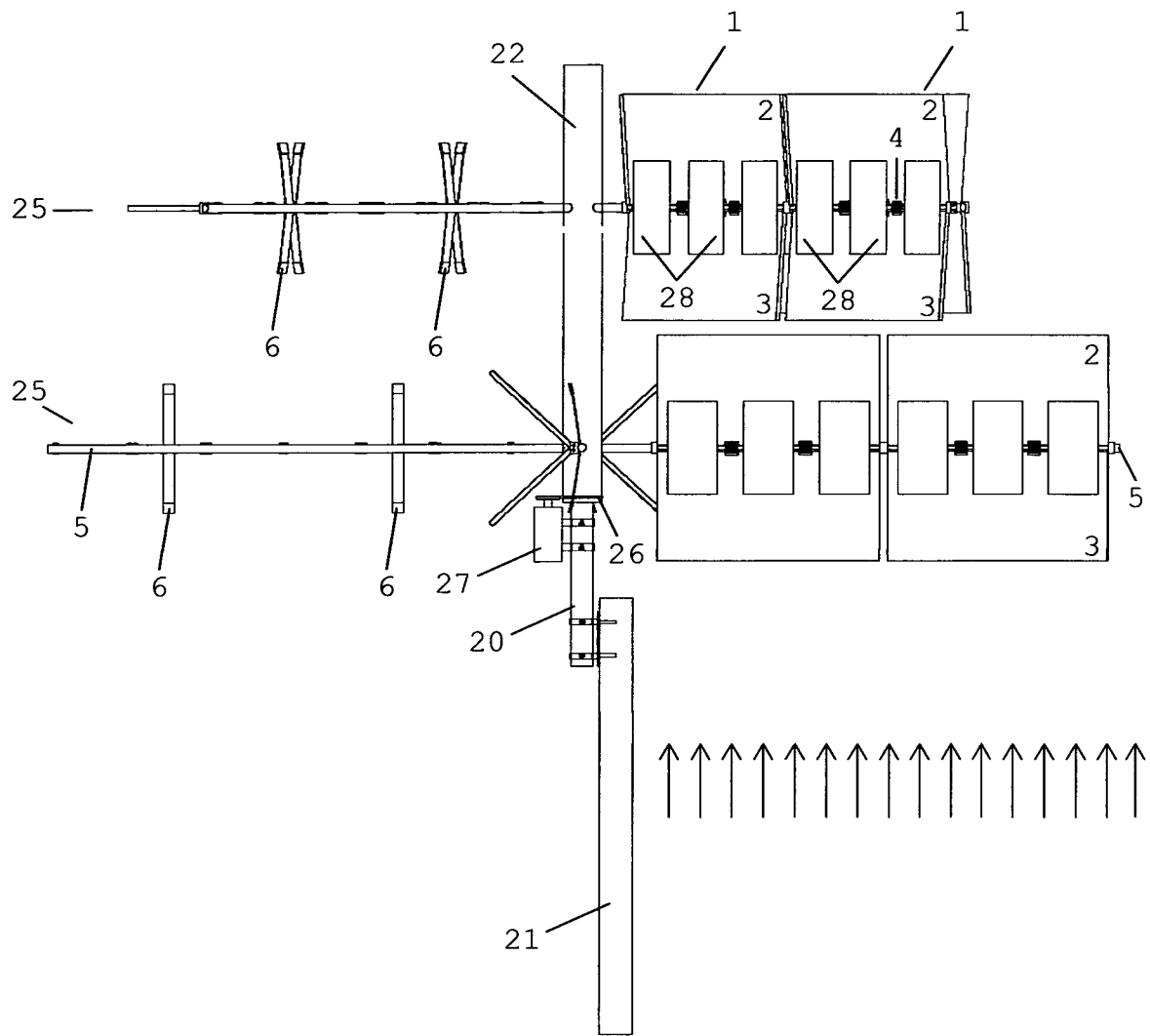

FIG. 15

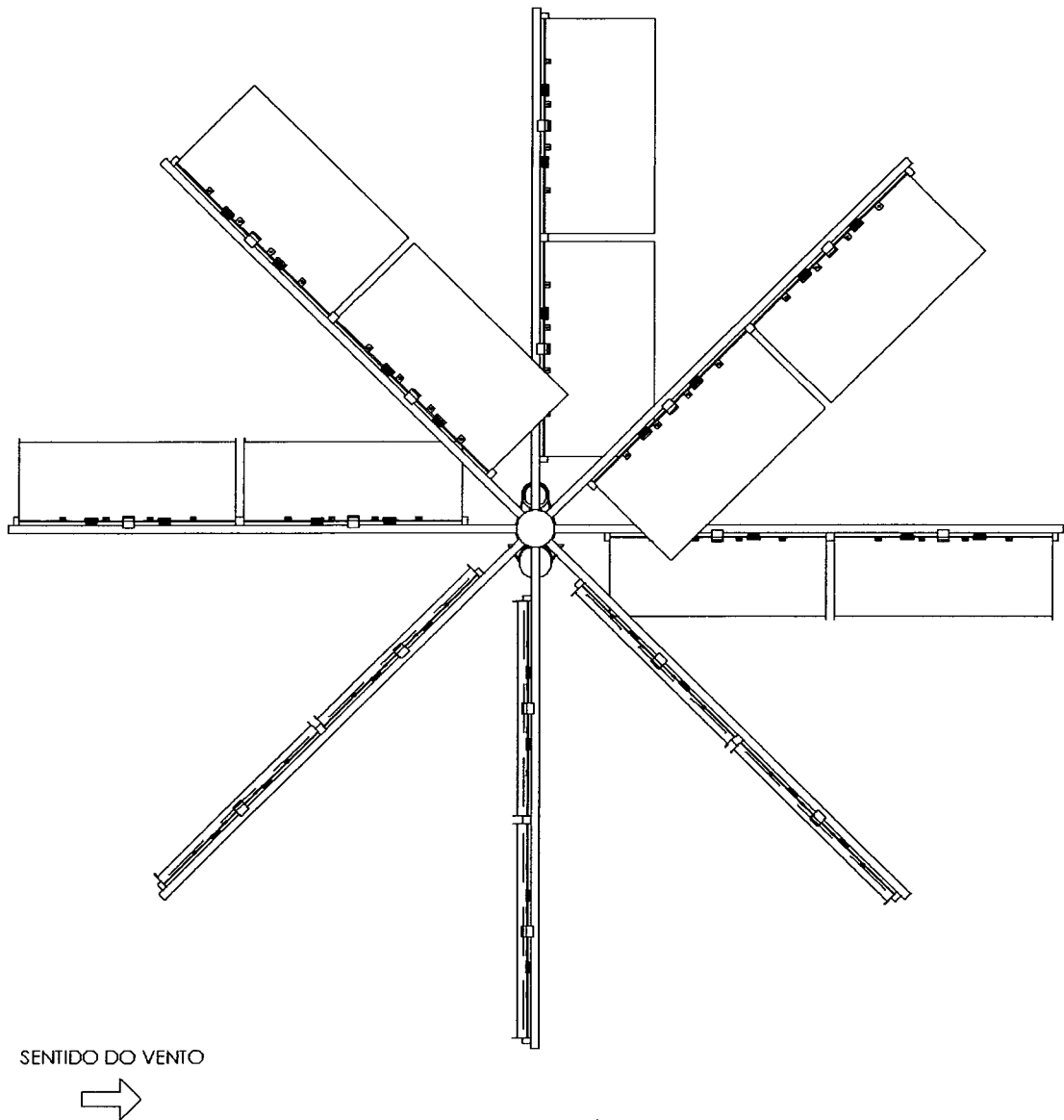

FIG.16

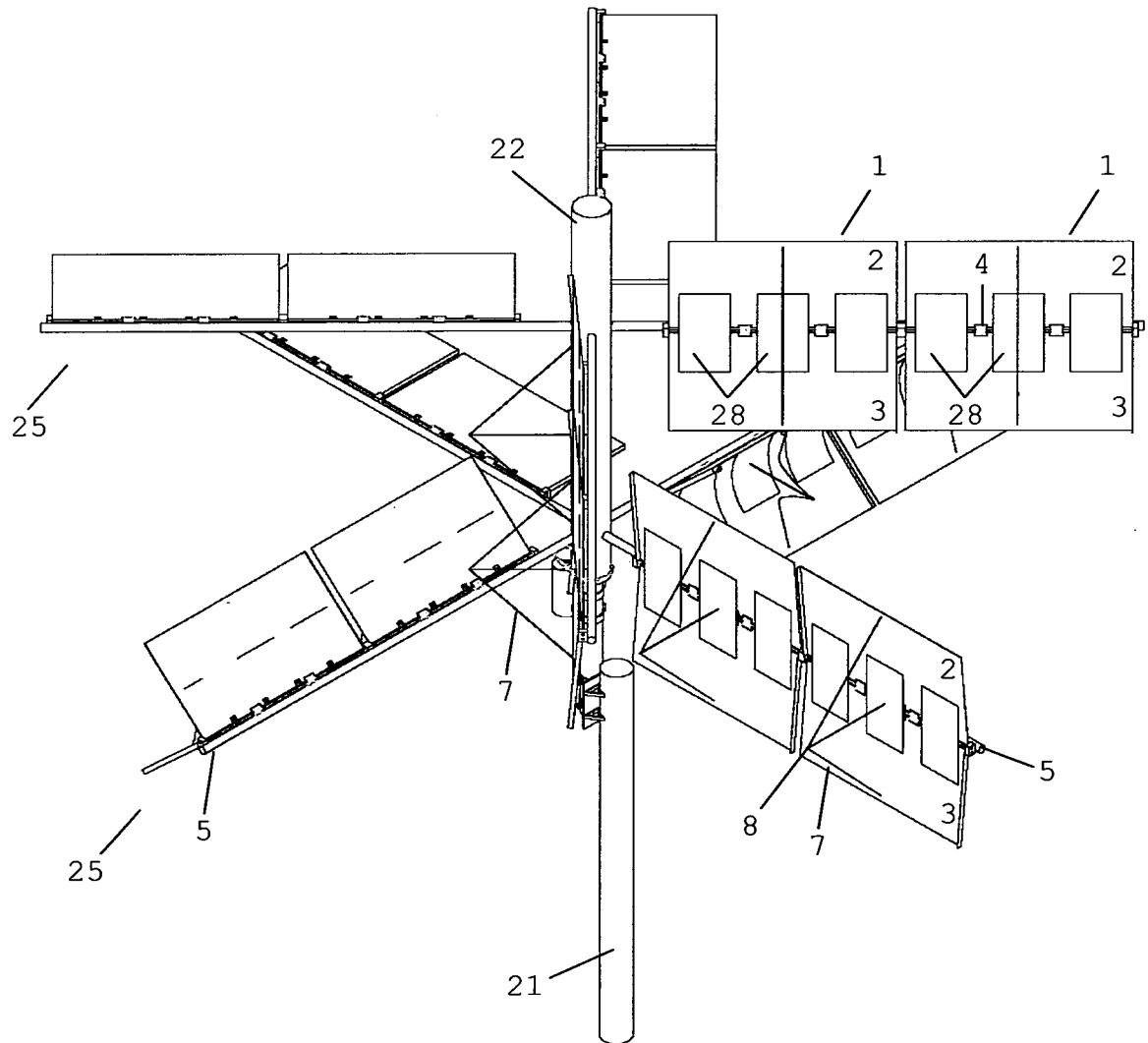

FIG. 17

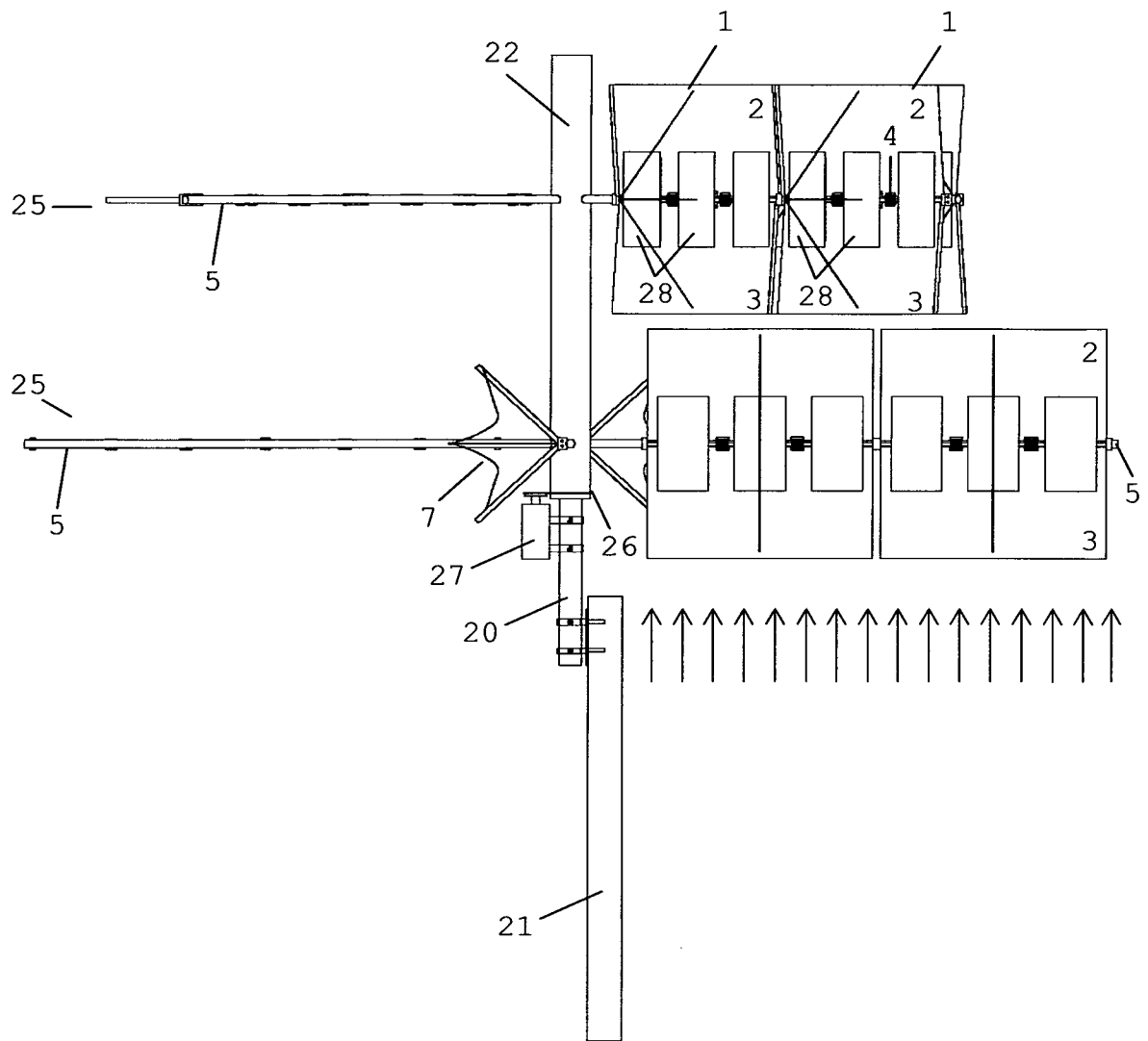

FIG. 18

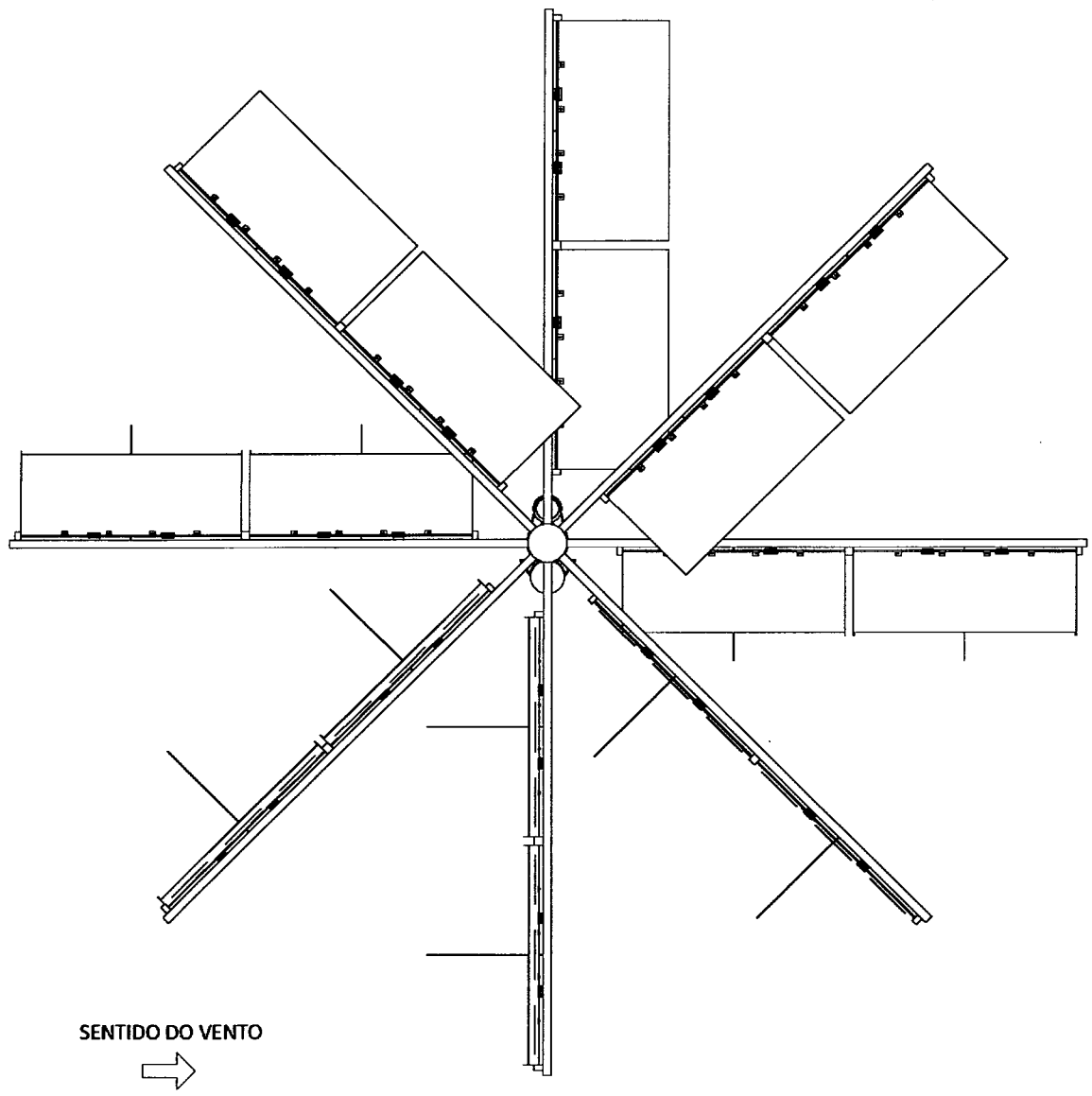

FIG. 19

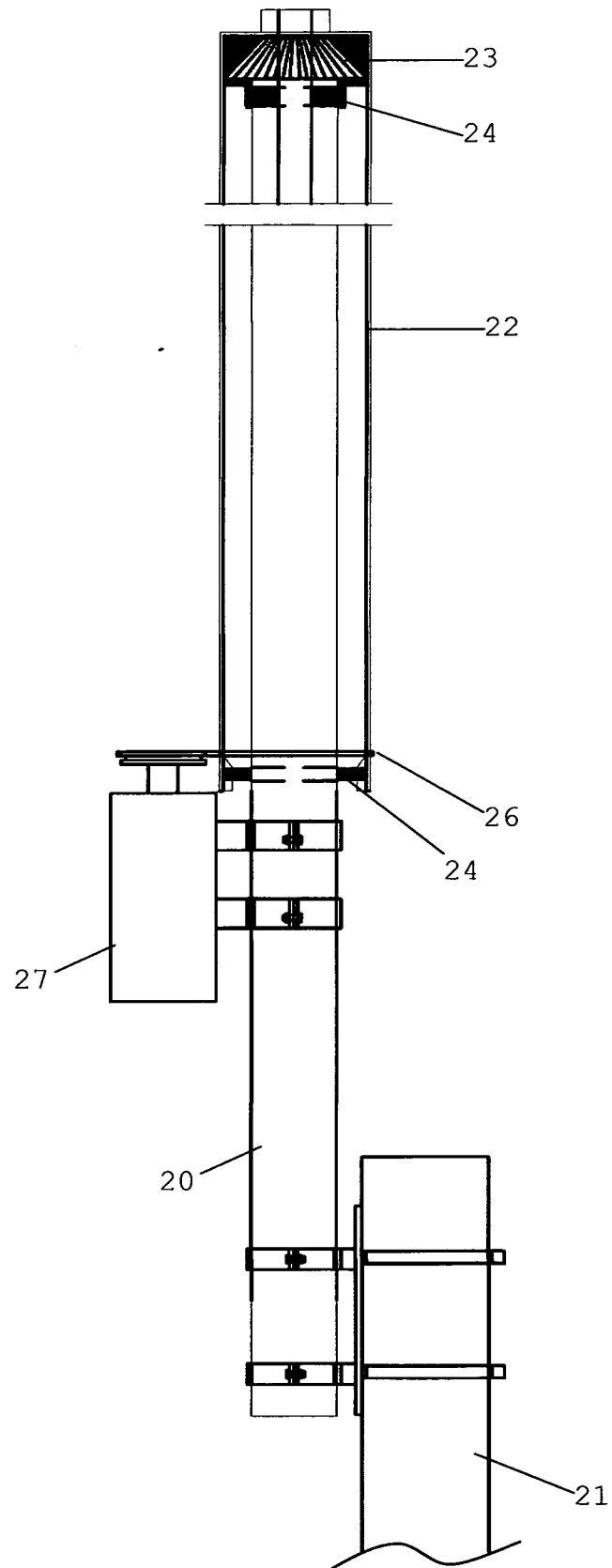

FIG. 20

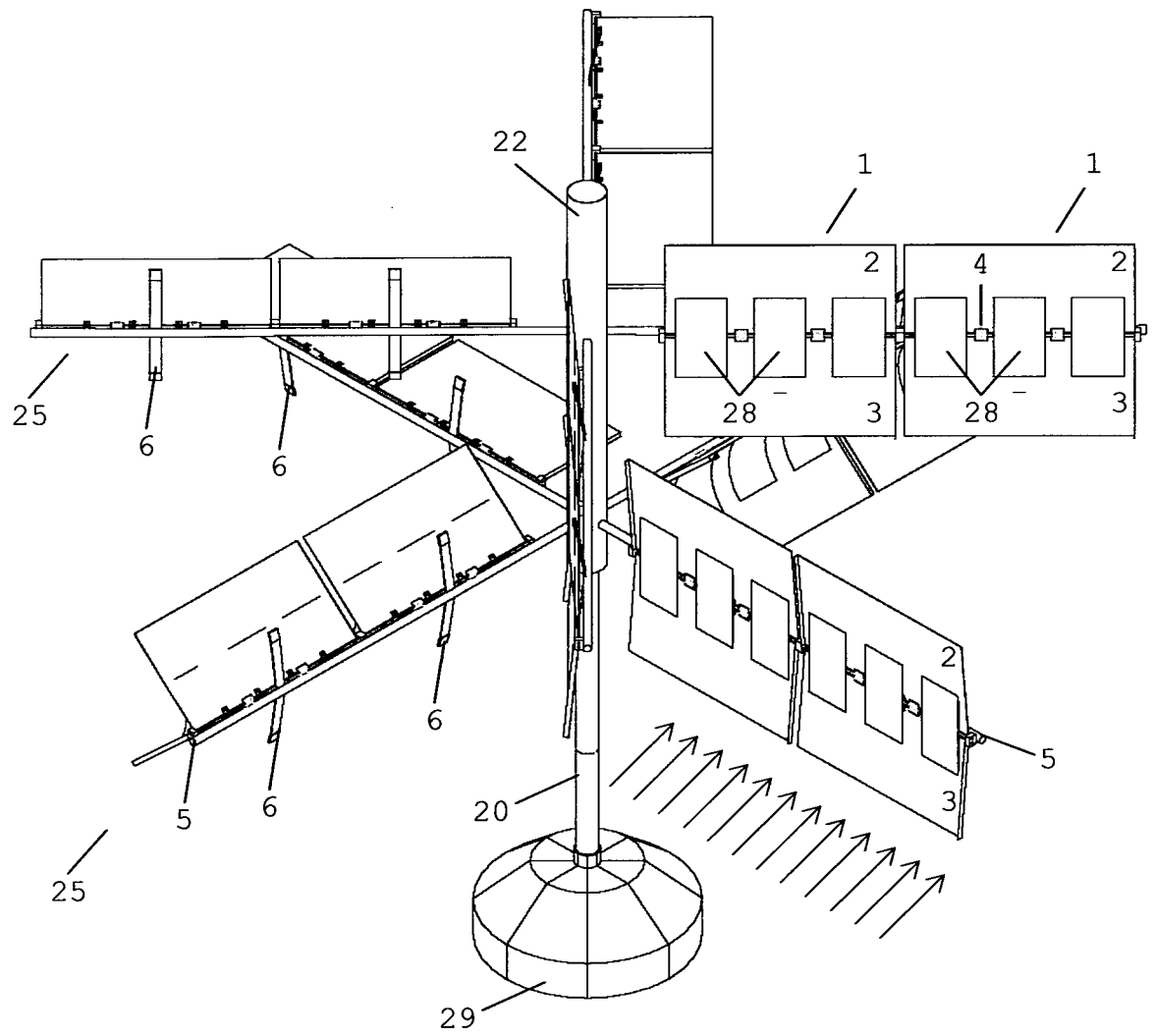

FIG. 21

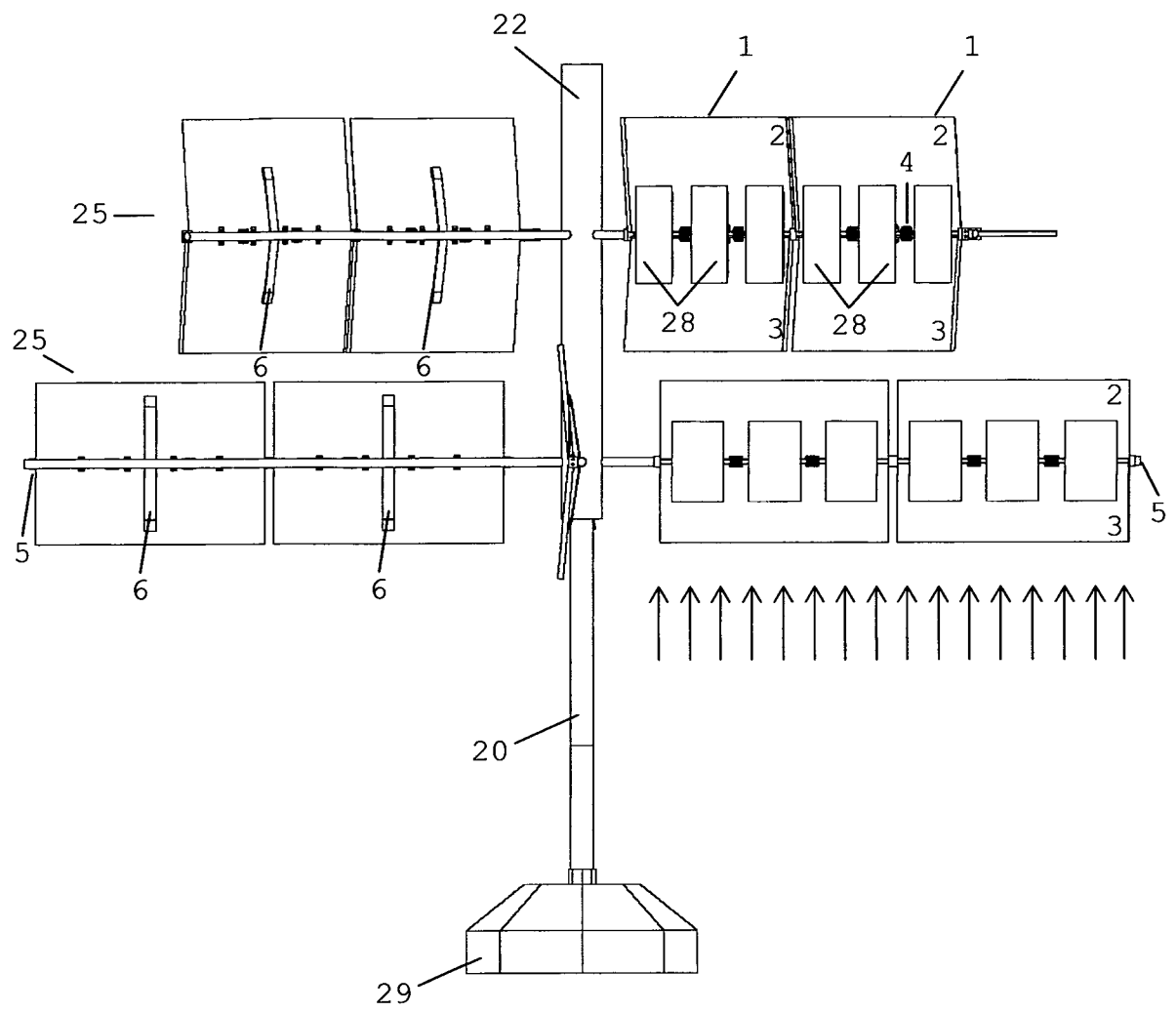
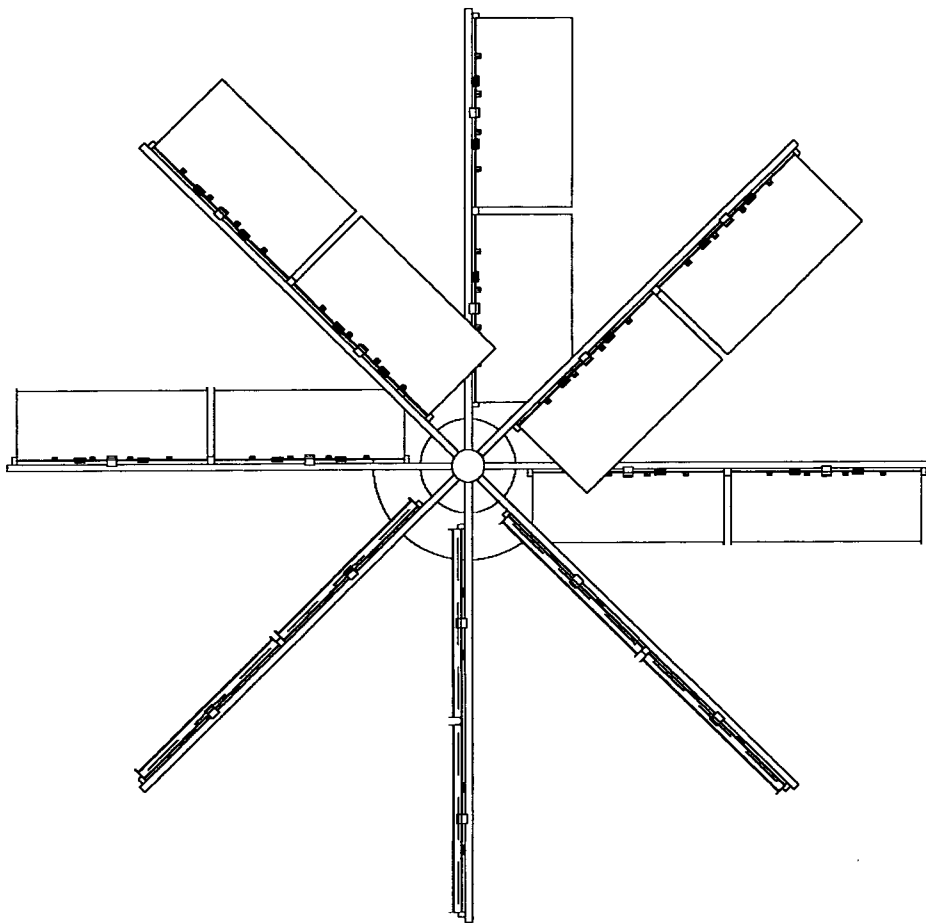

FIG. 22



SENTIDO DO VENTO



FIG. 23

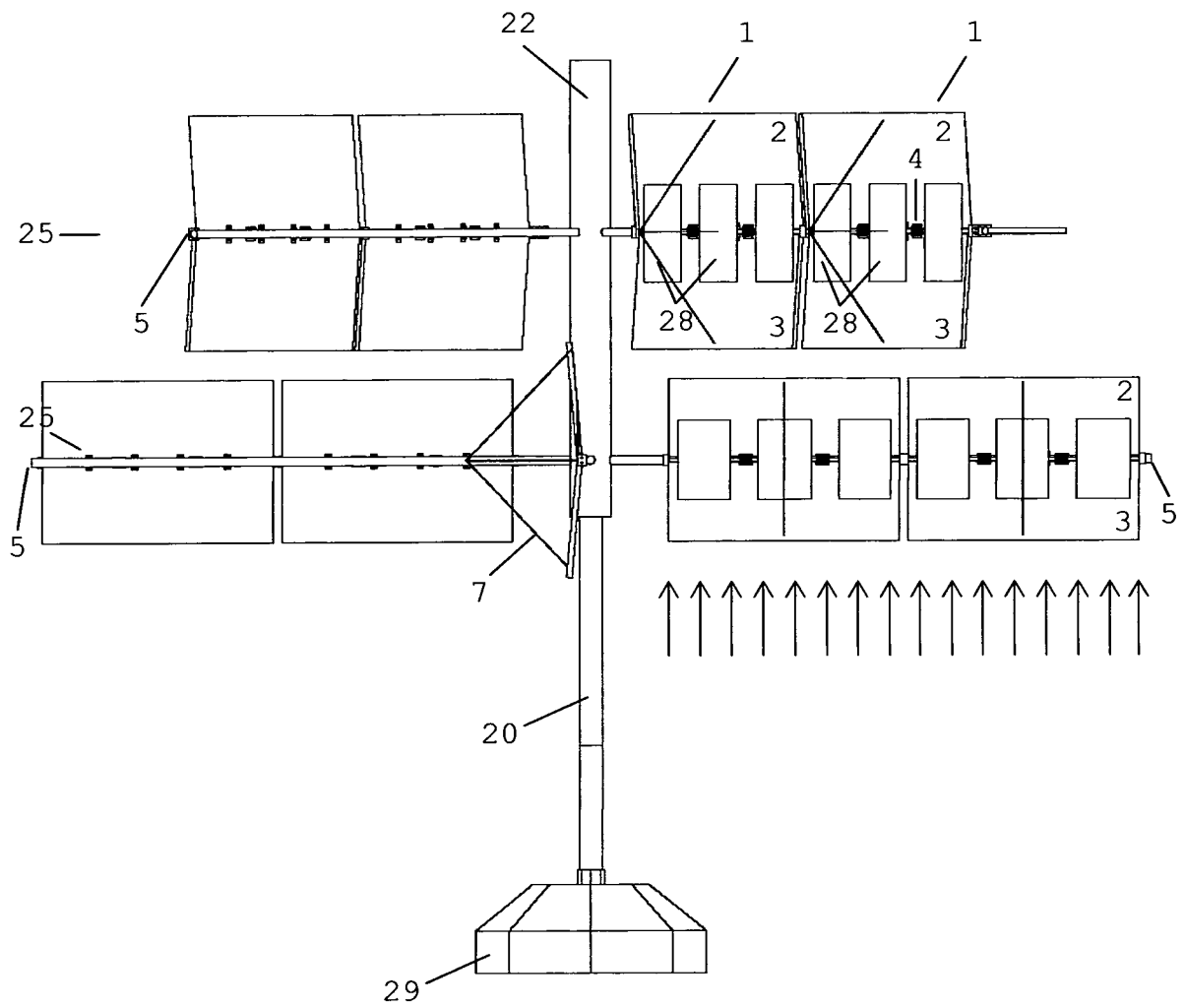

FIG. 25

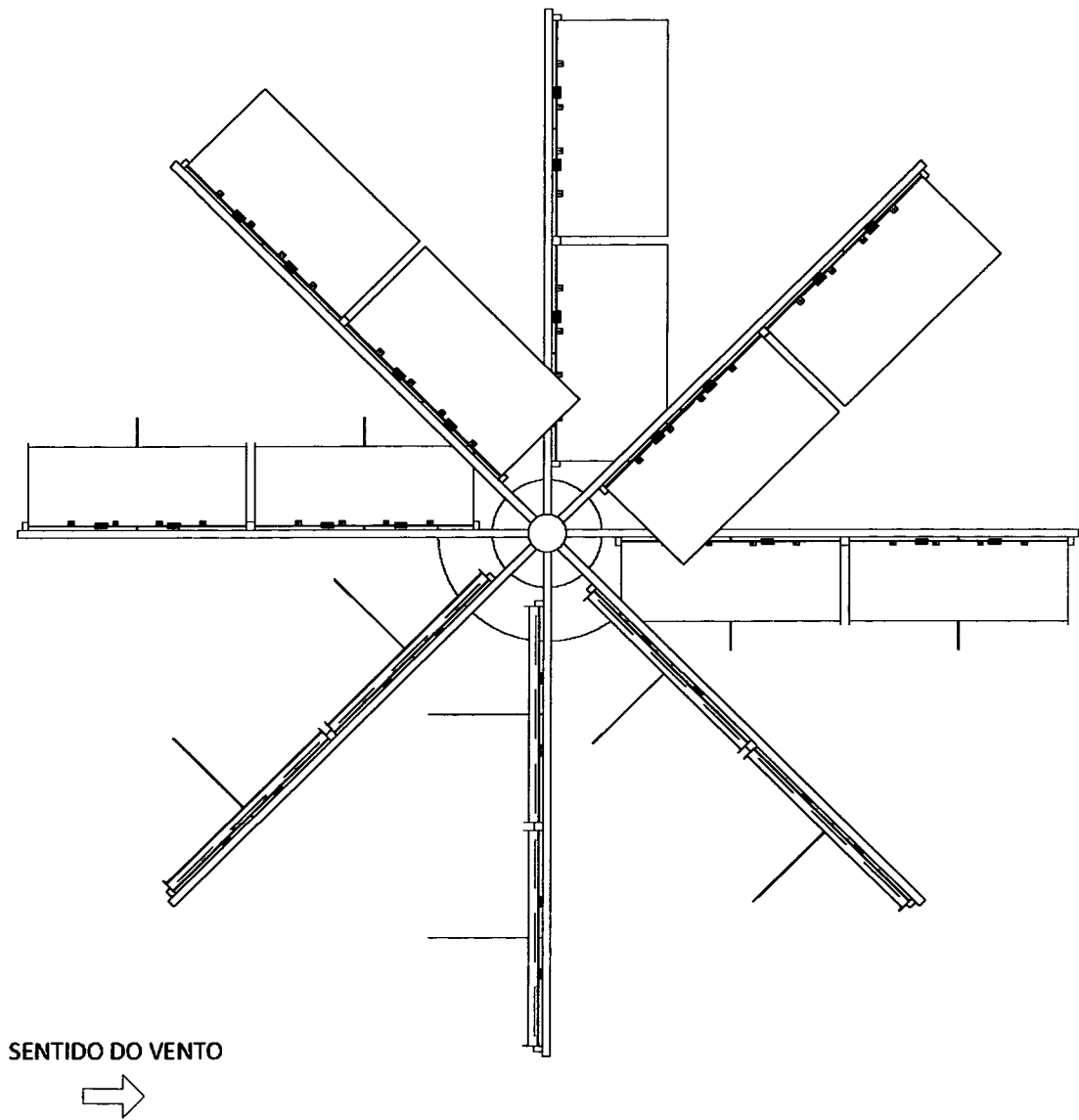

FIG. 26

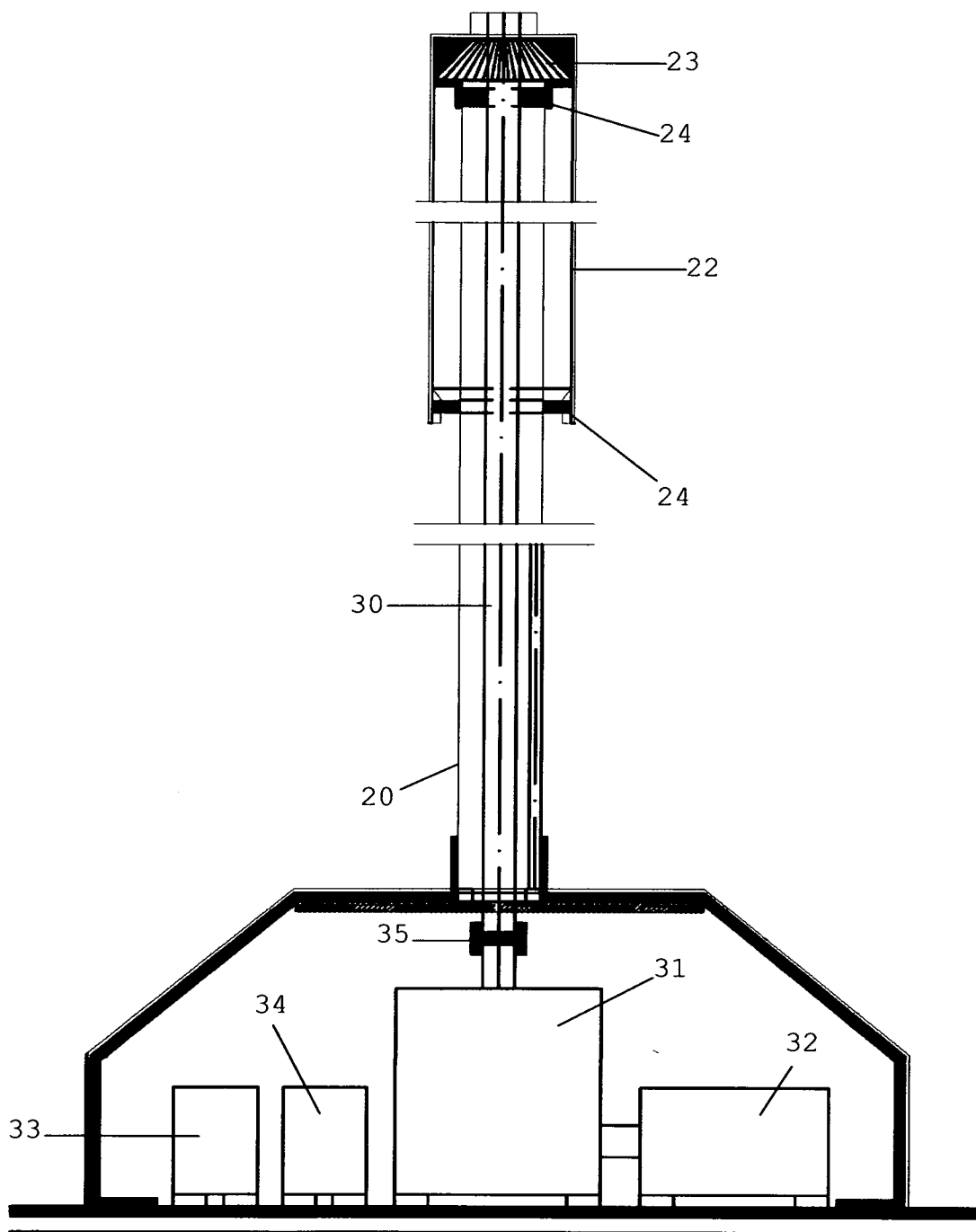

FIG. 27

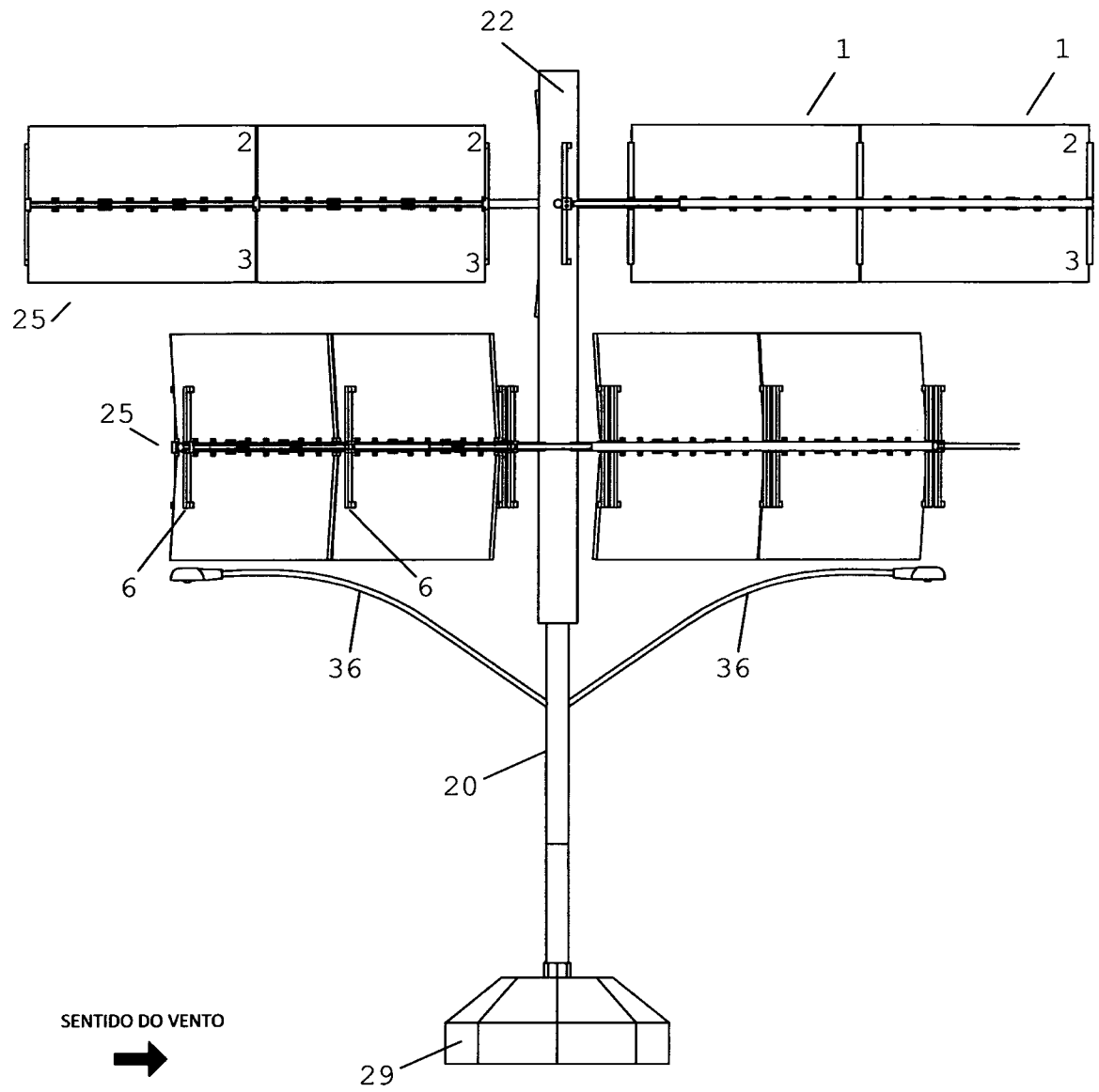

FIG. 28

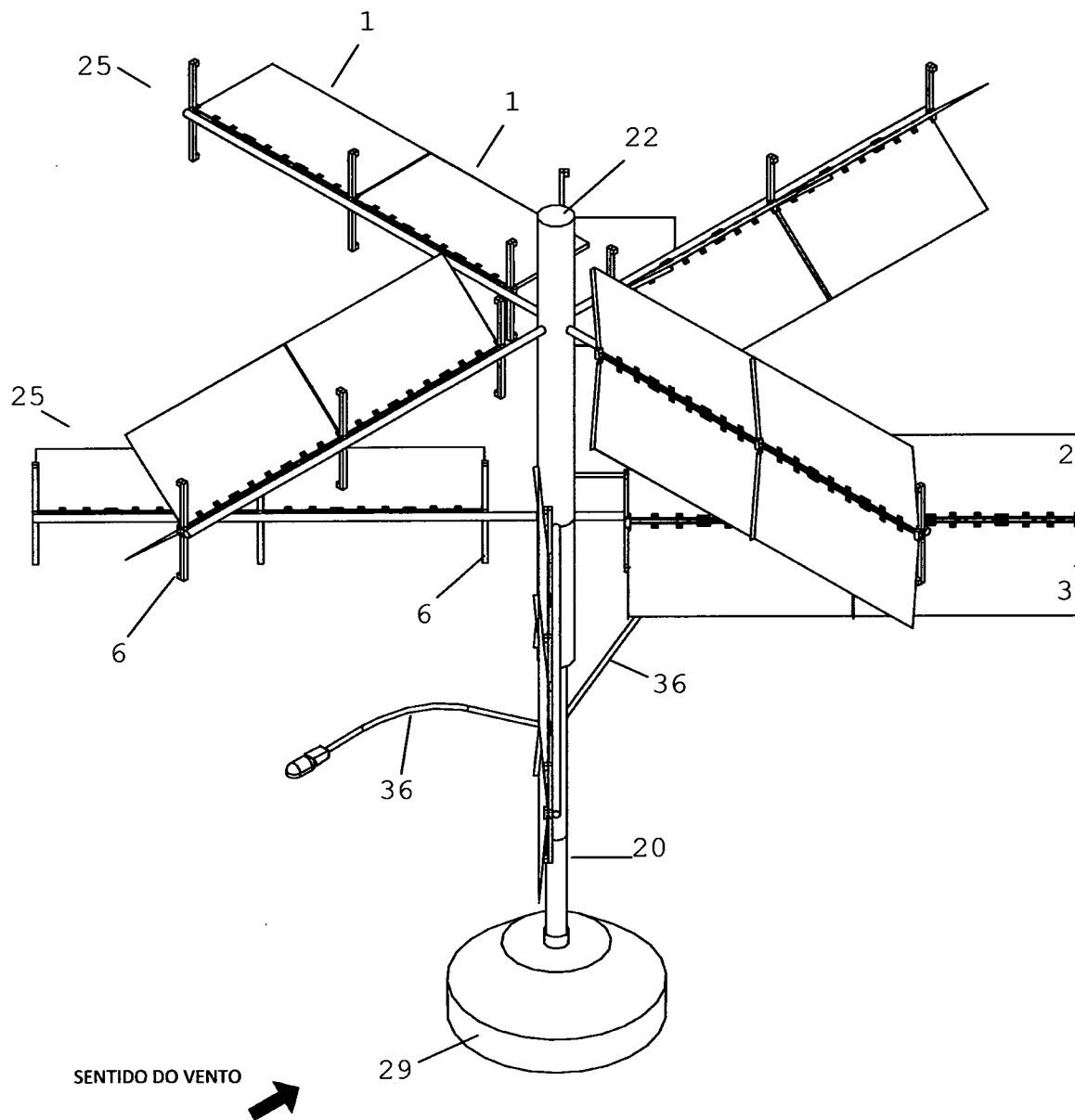

FIG. 29

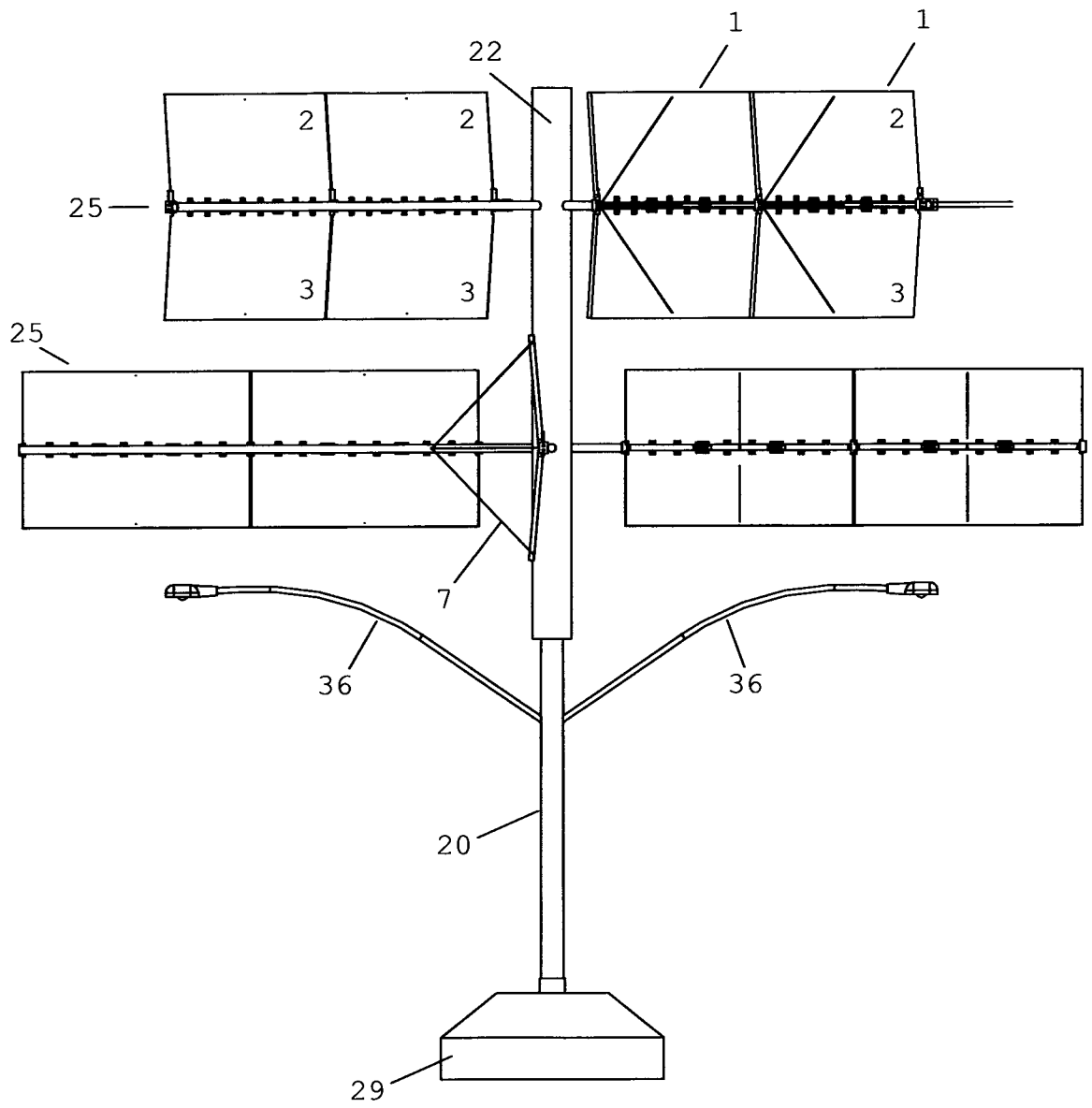

FIG. 30

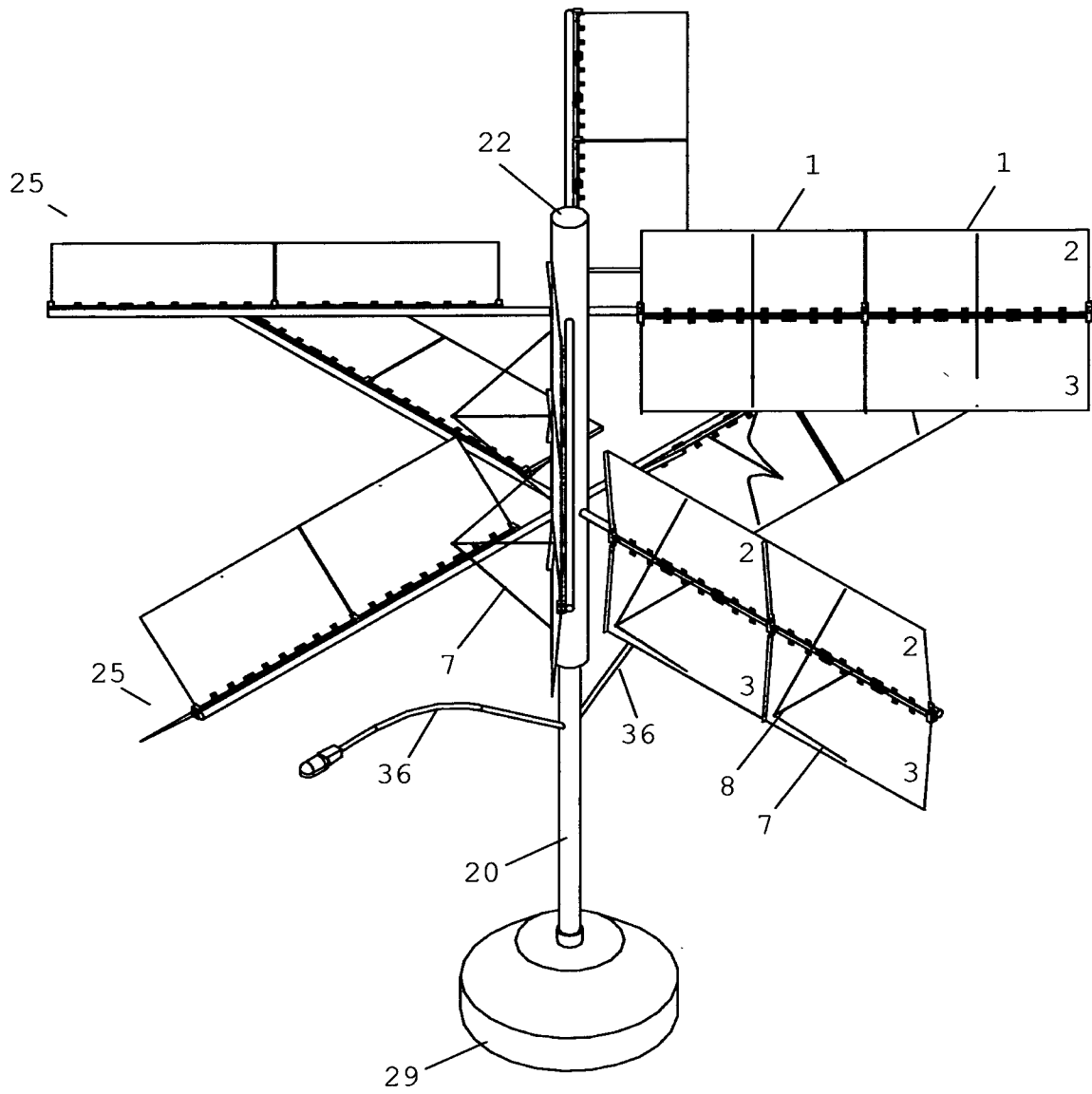

FIG. 31

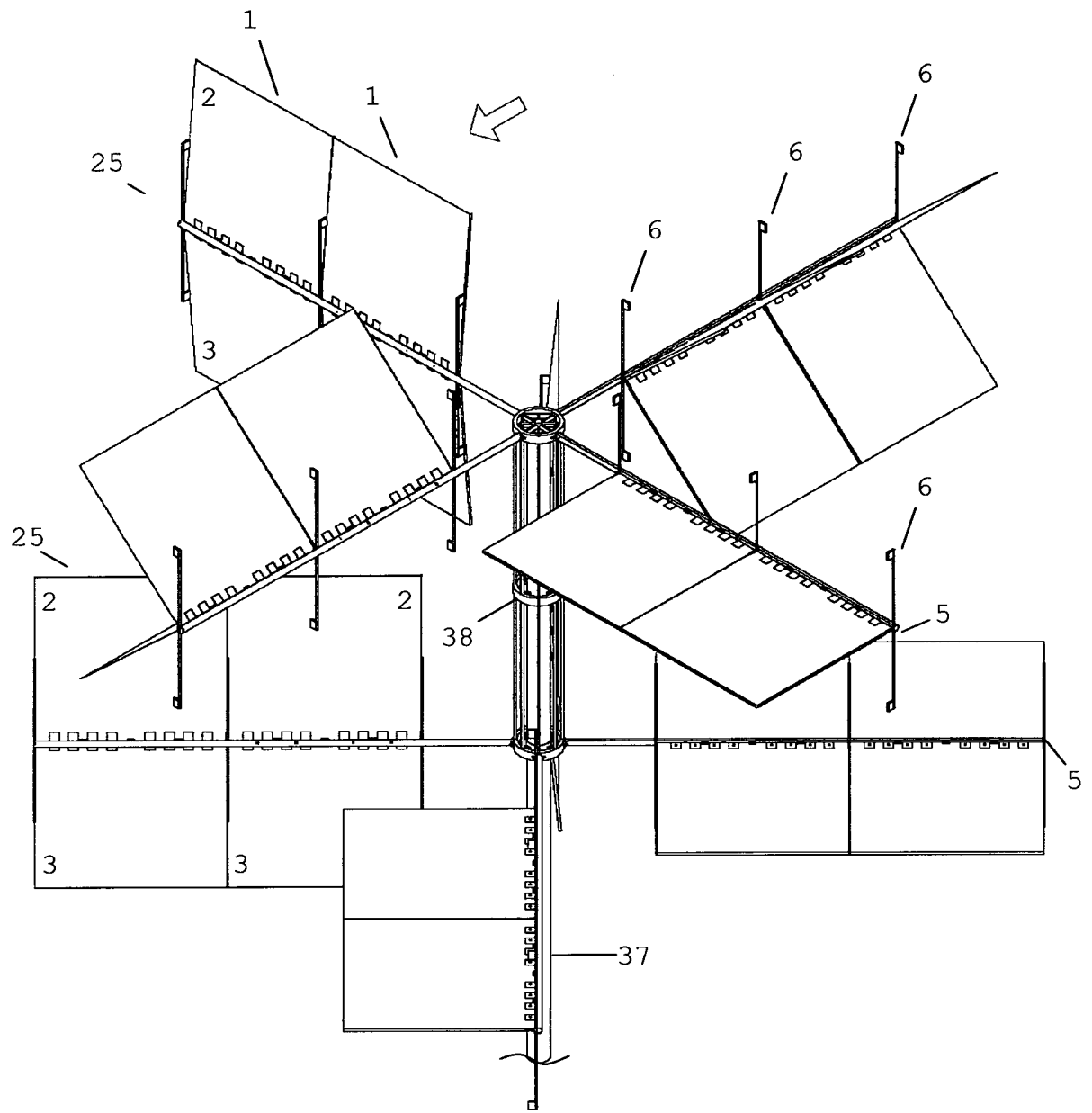

FIG. 32

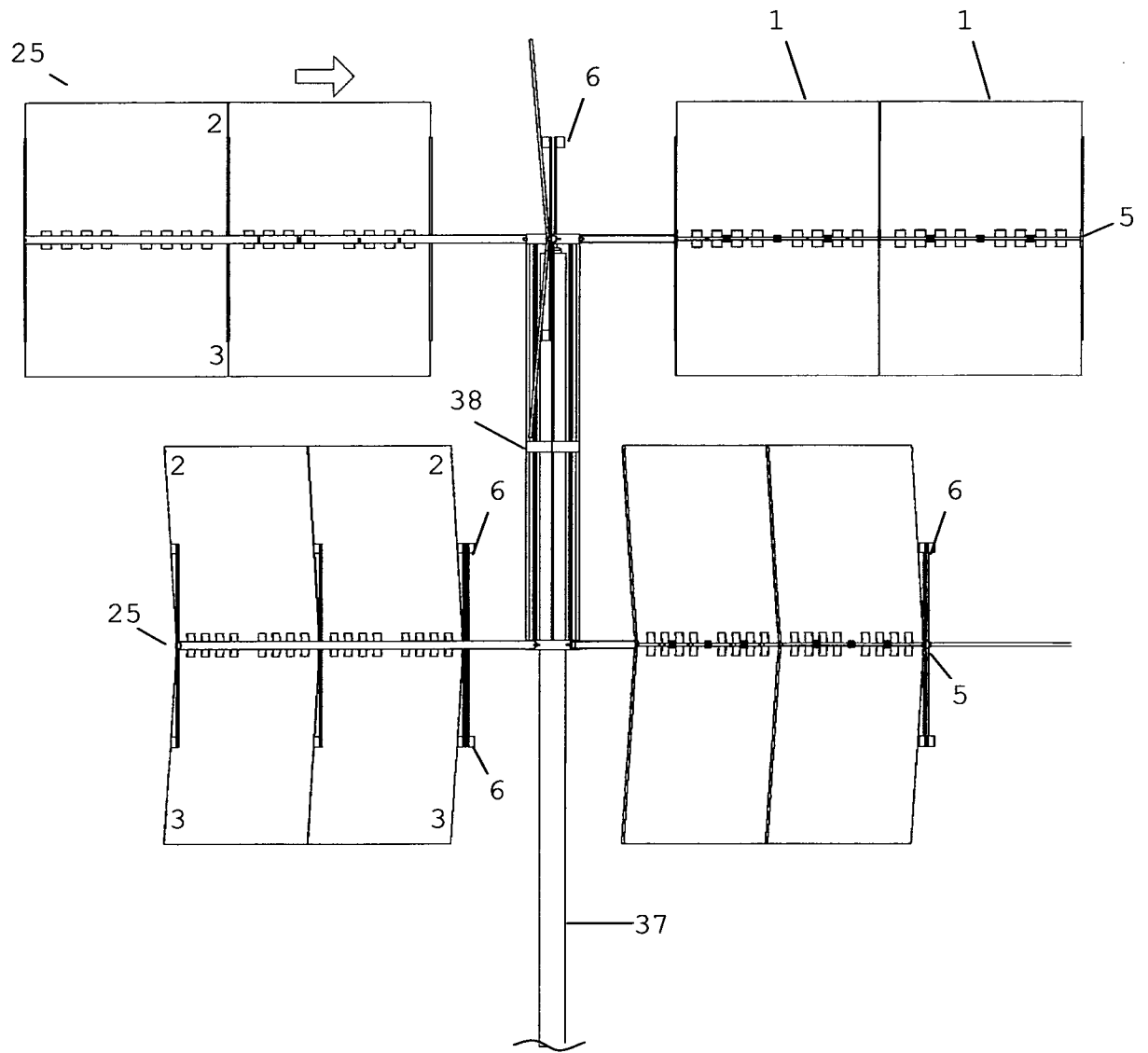

FIG. 33

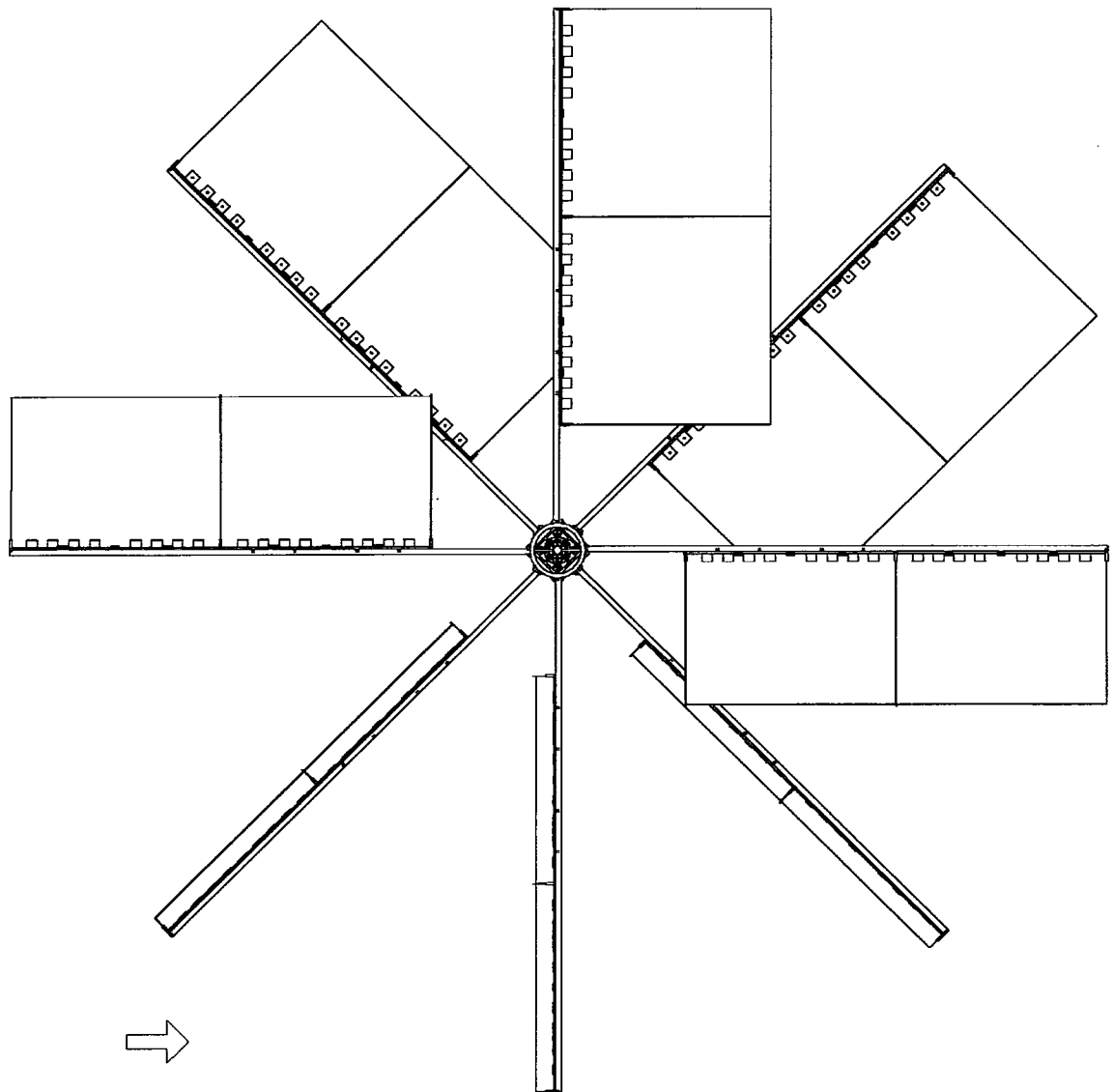

FIG. 34

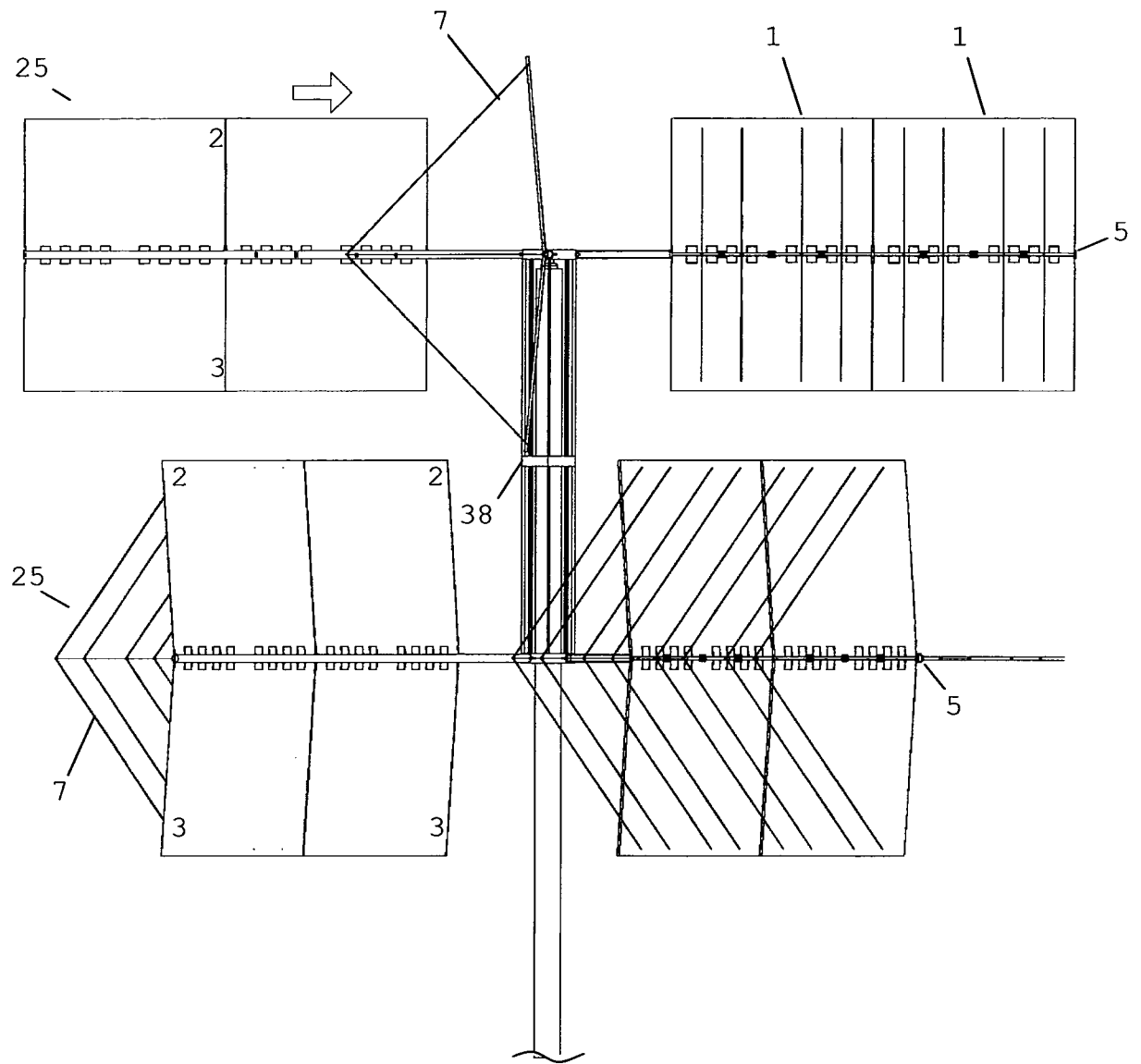

FIG. 35

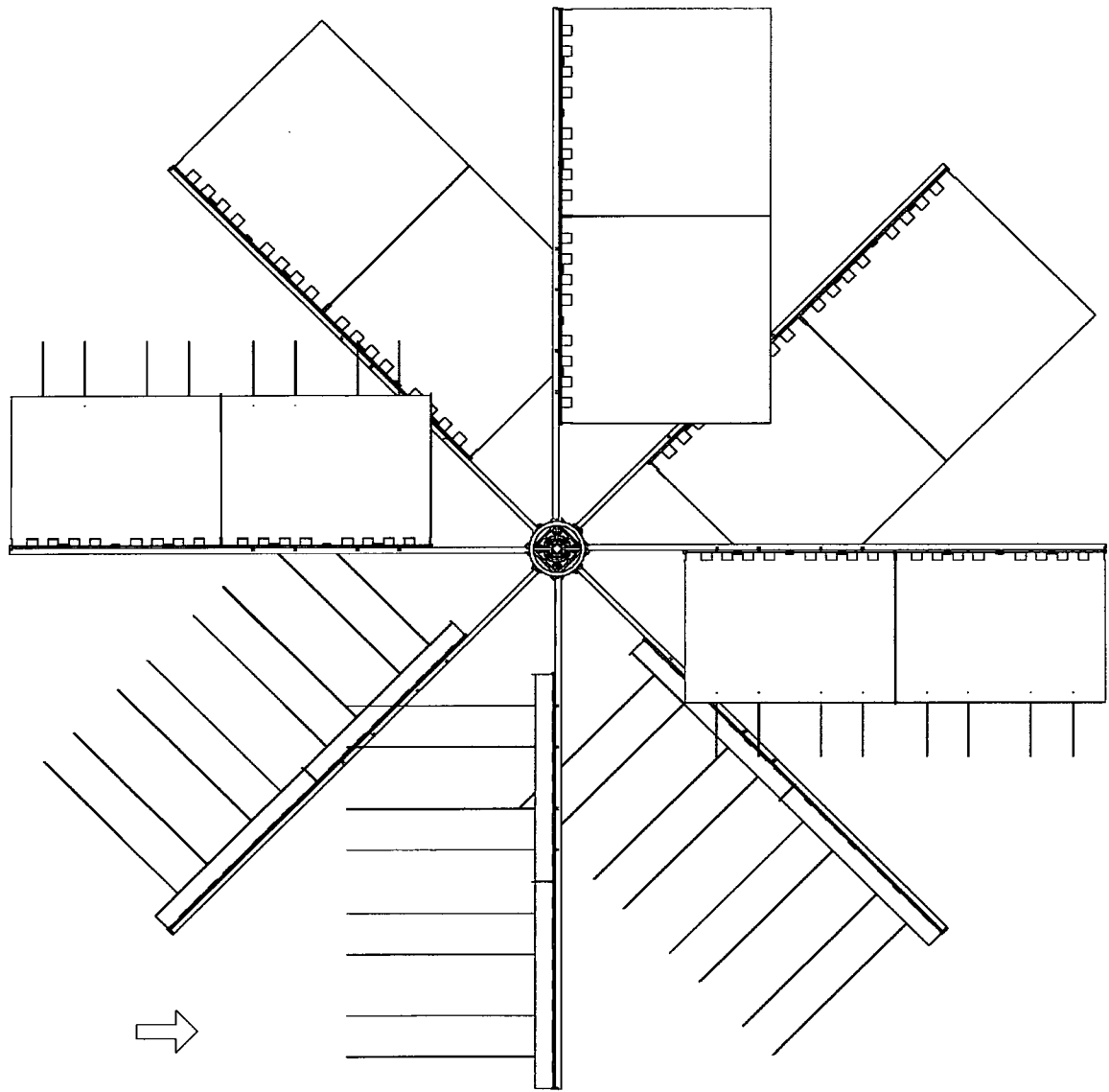

FIG. 36

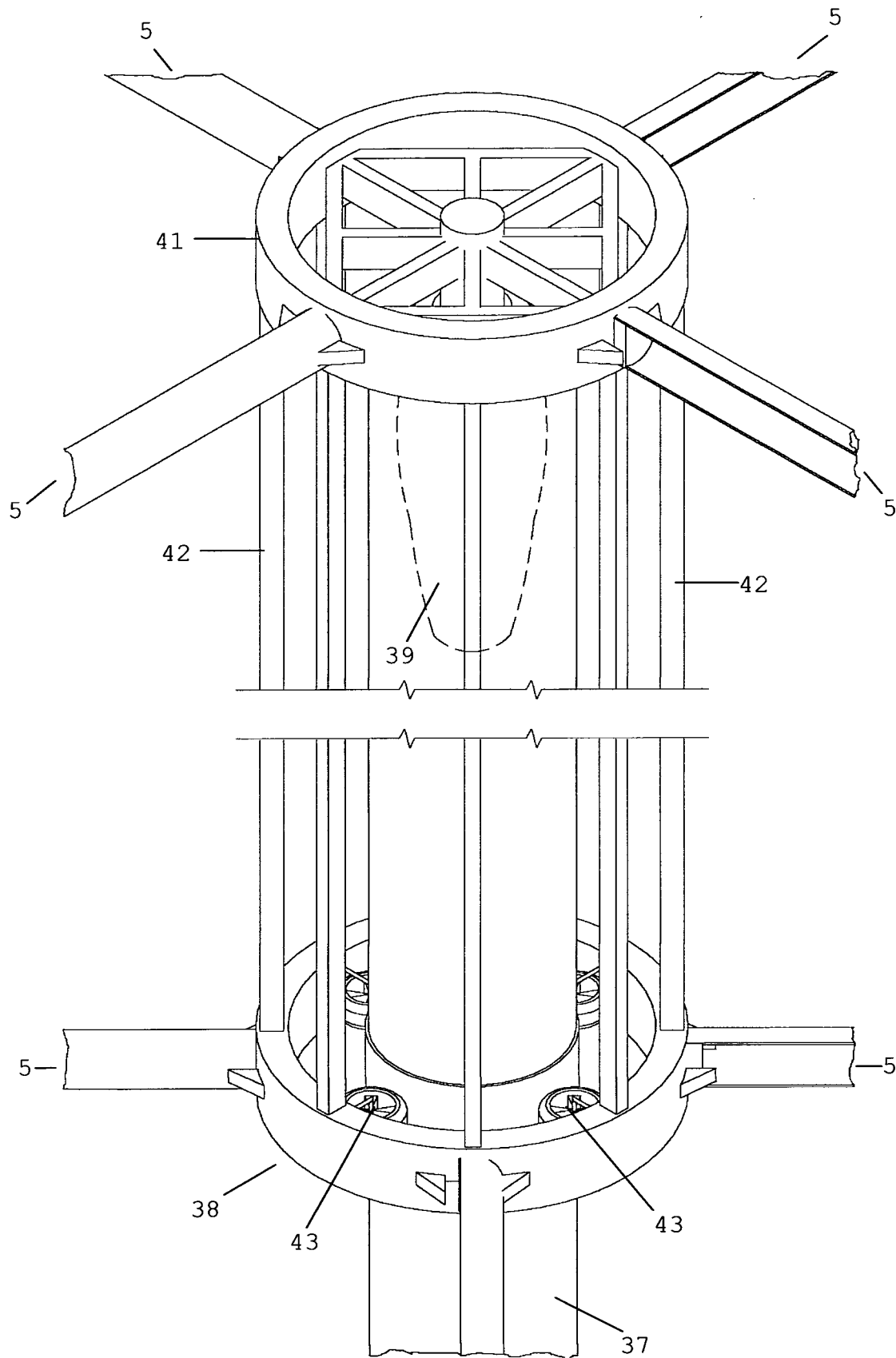

FIG. 37

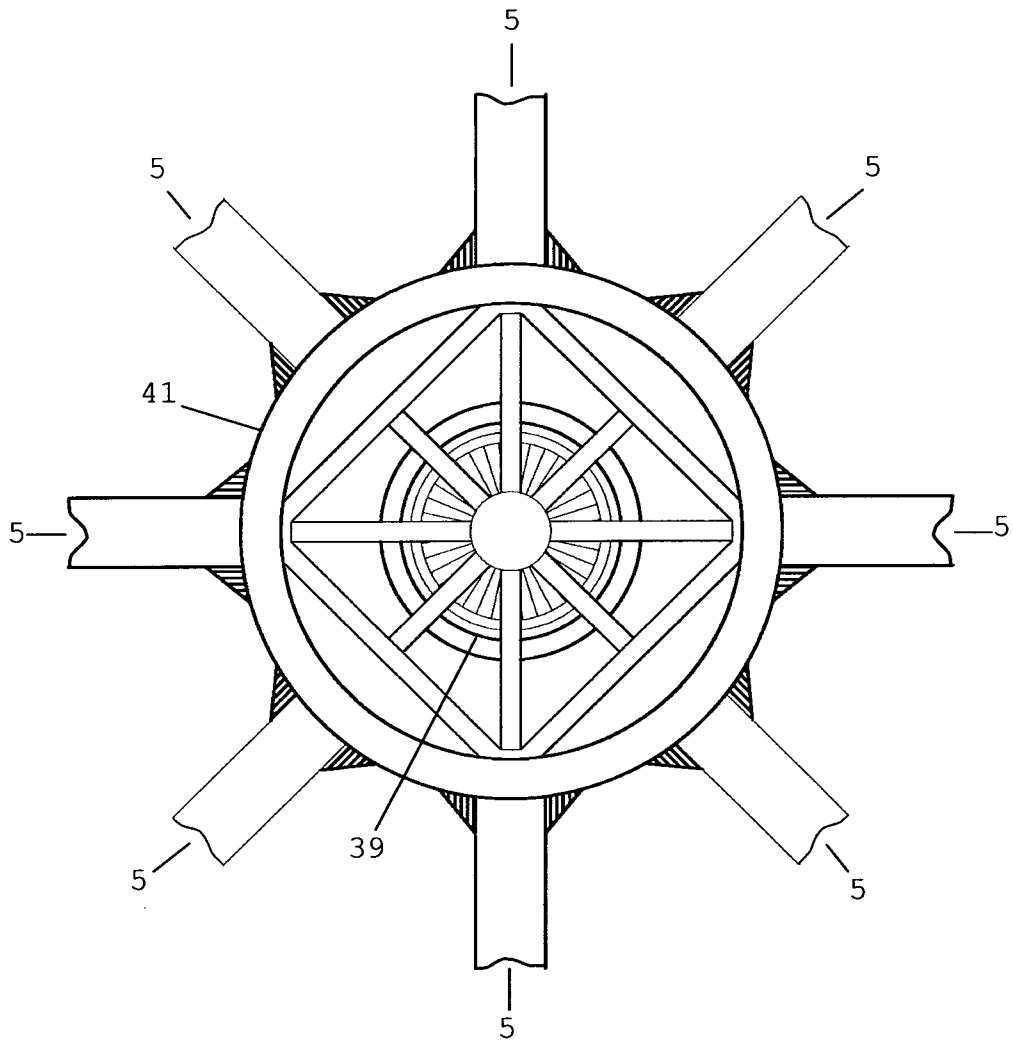

FIG. 38

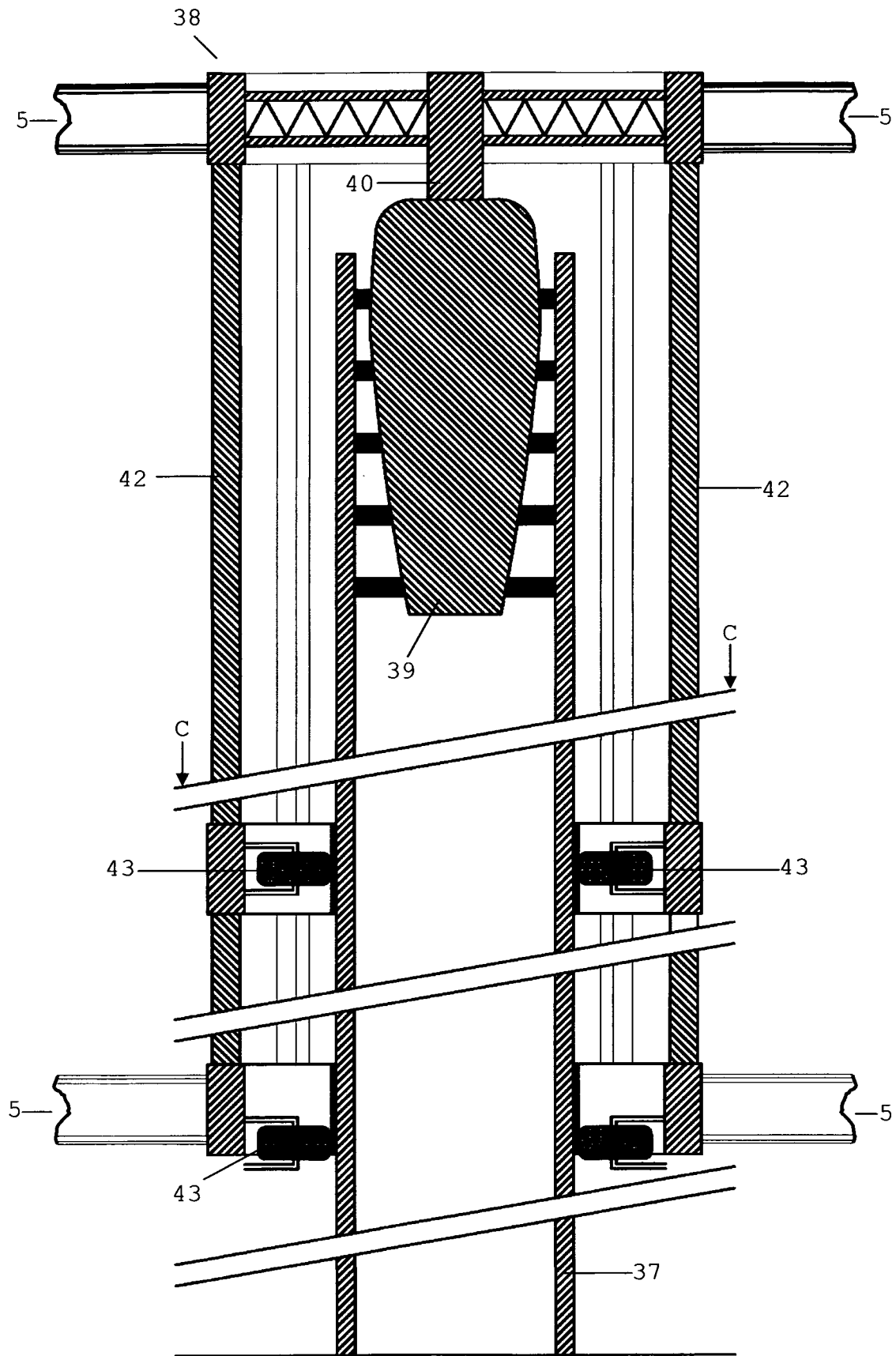

FIG. 39

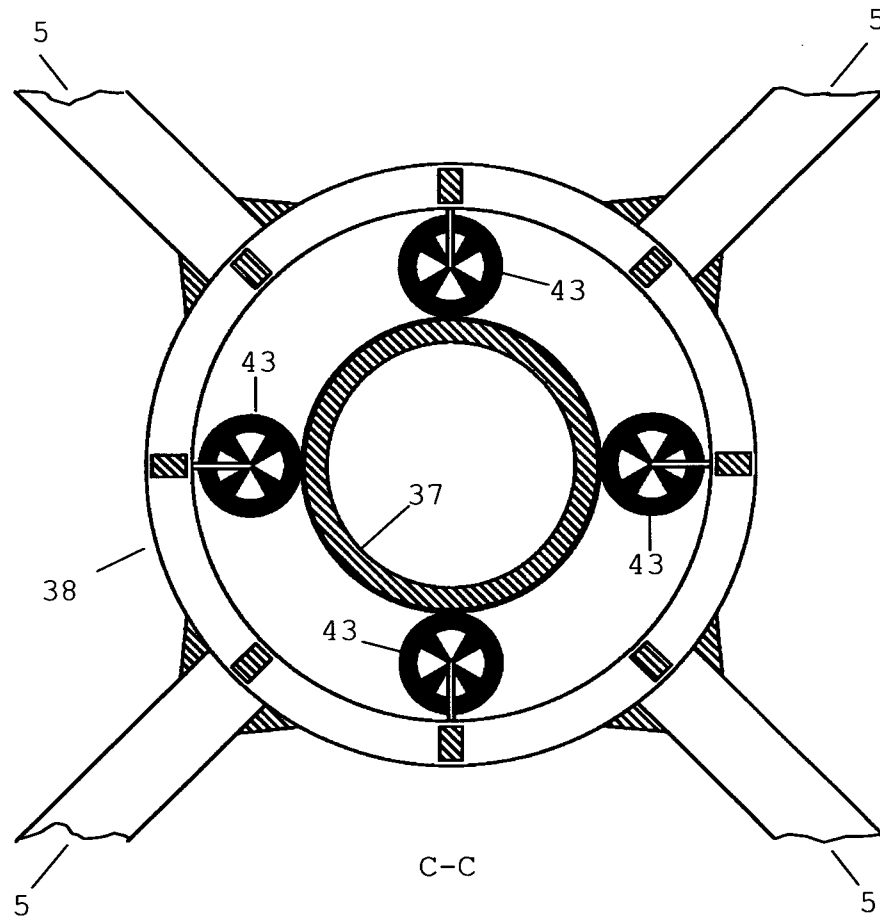

FIG. 40

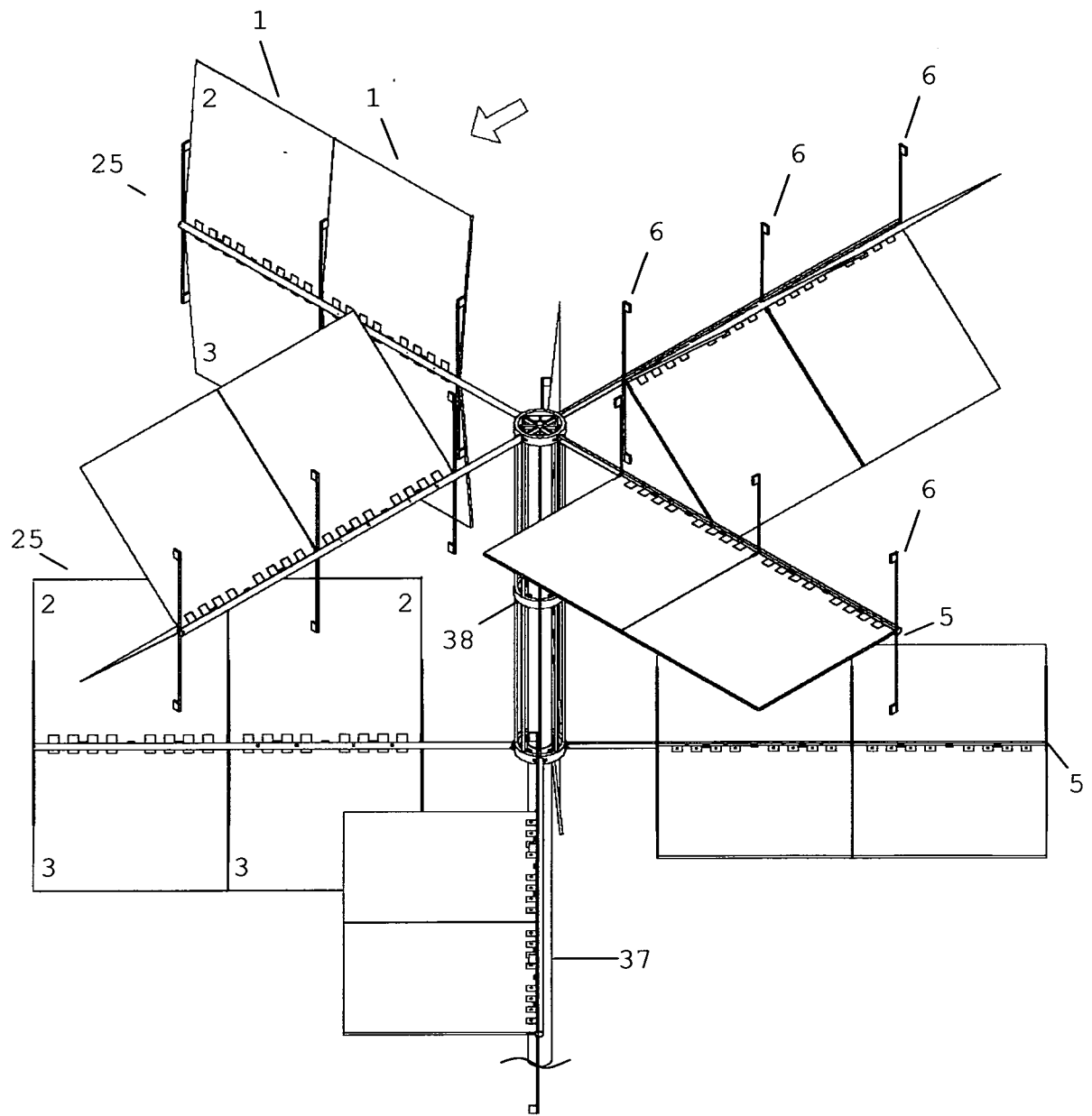

FIG. 41

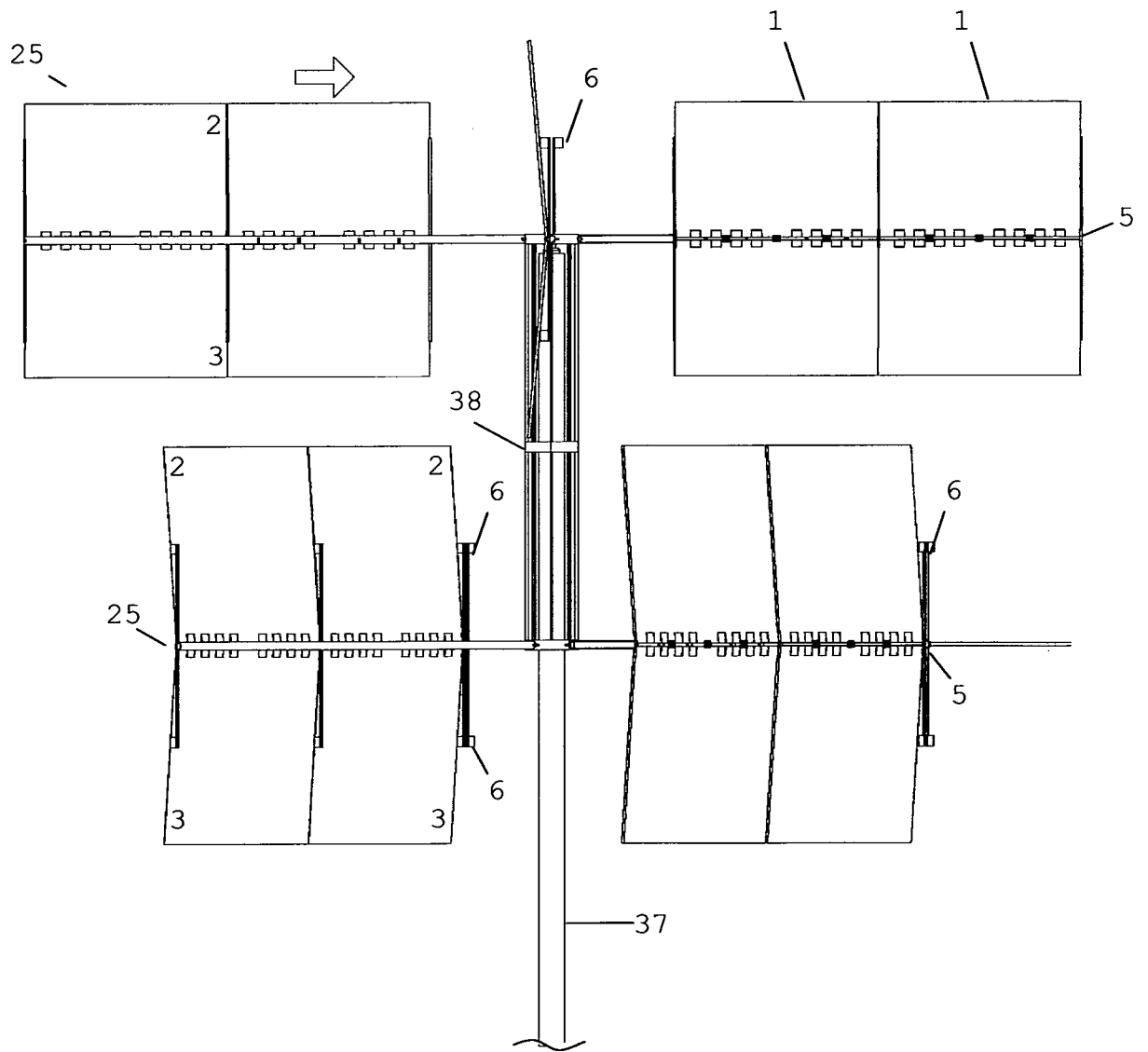

FIG. 42

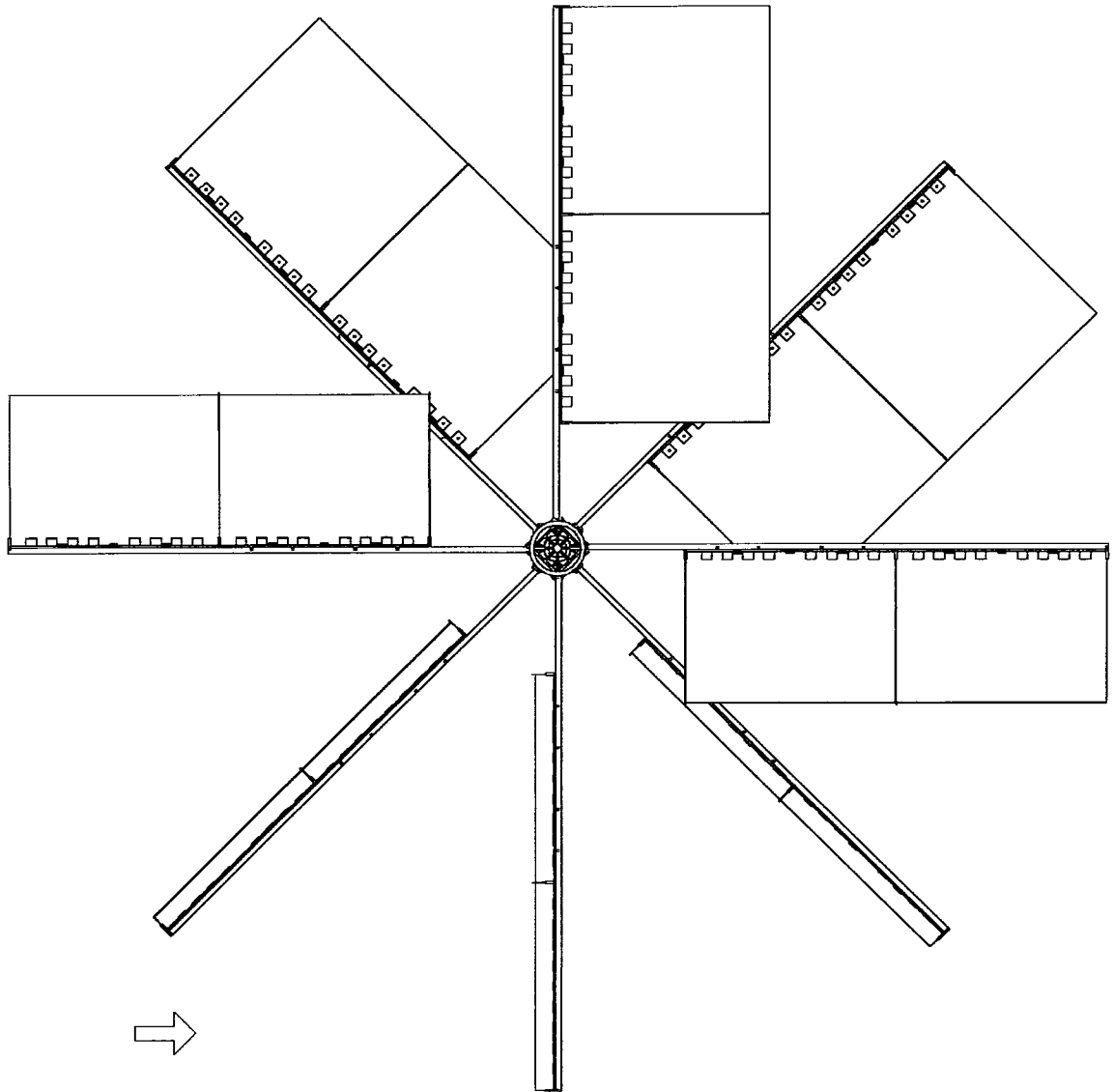

FIG. 43

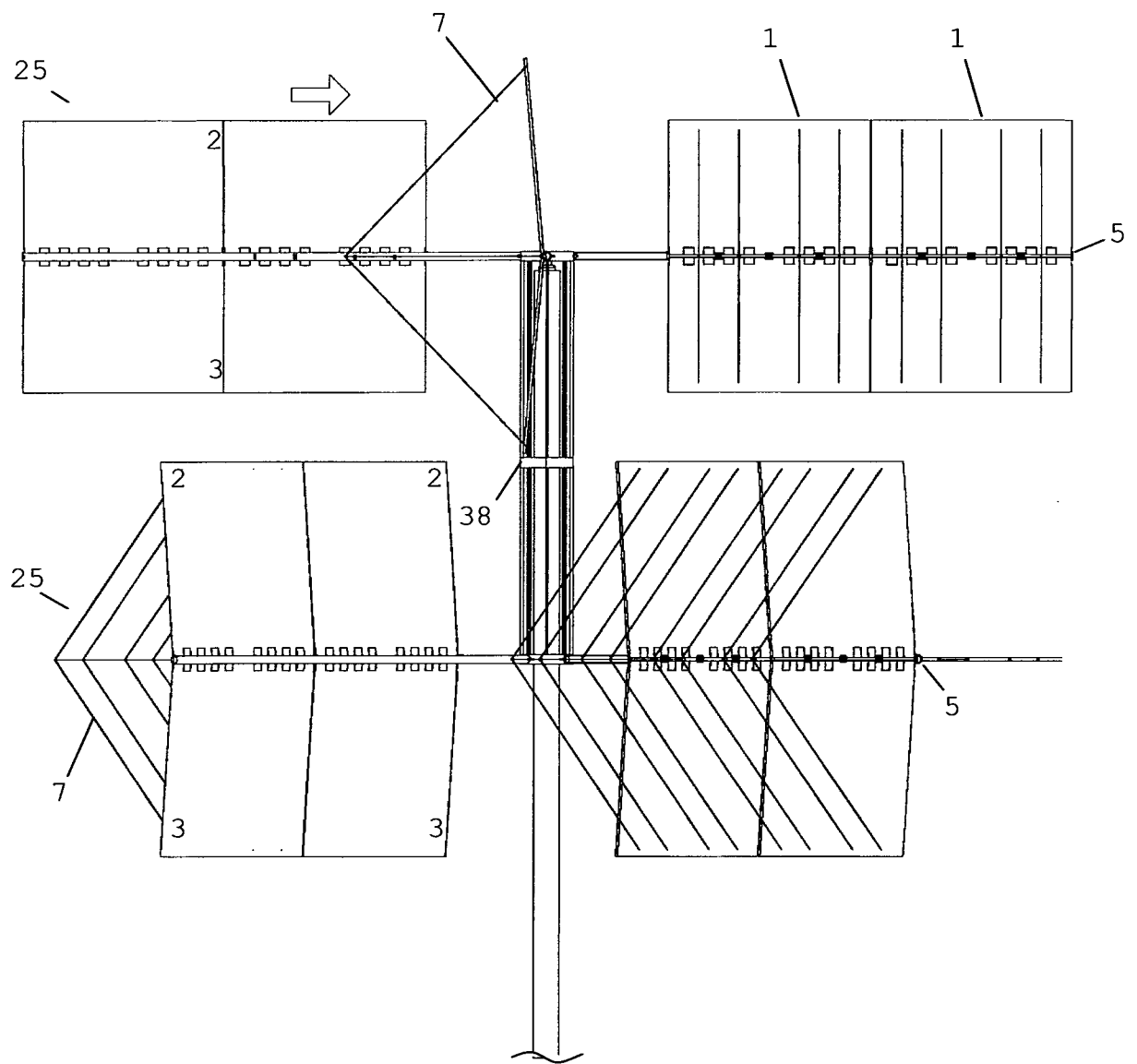

FIG. 45

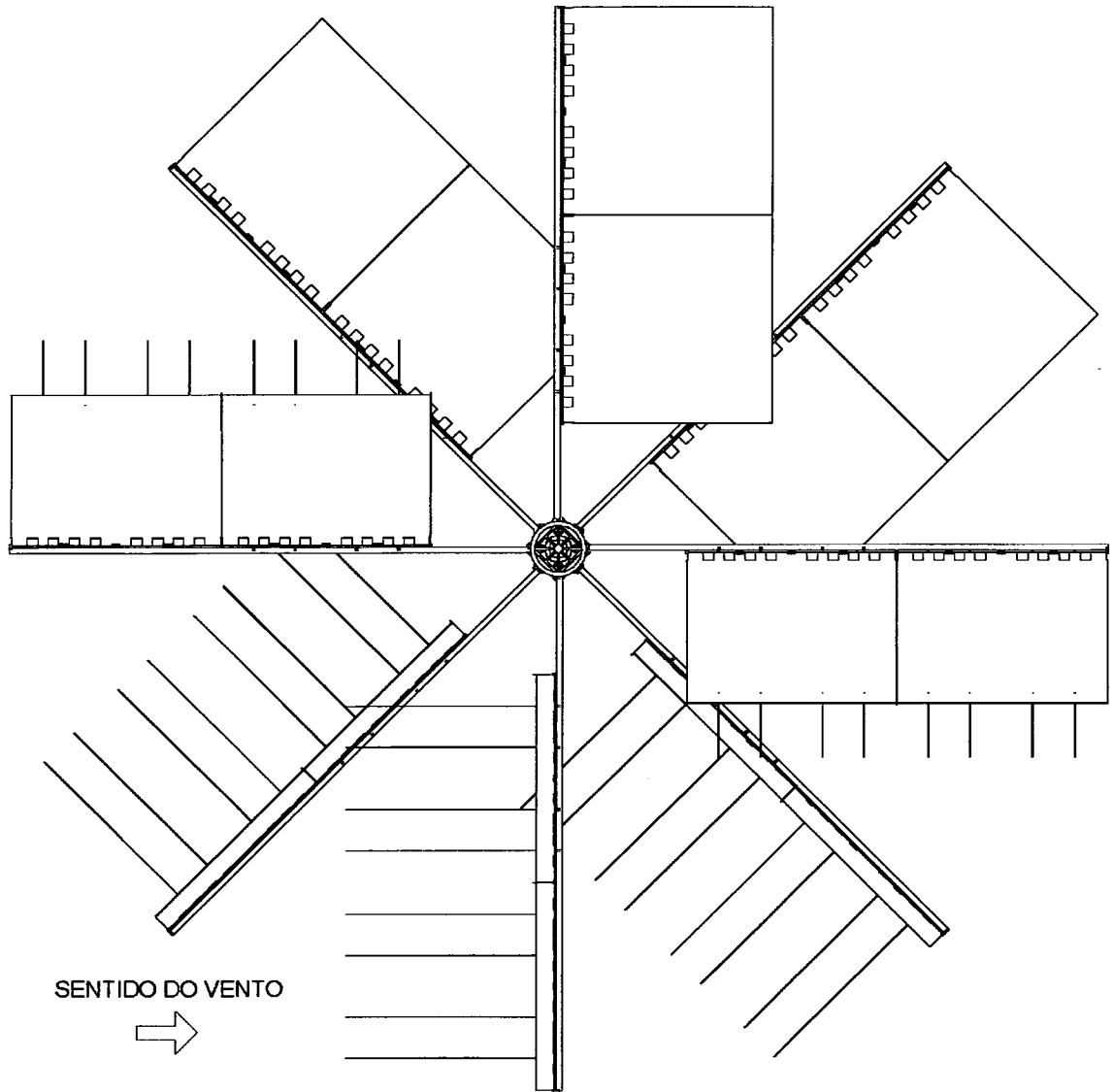

FIG. 46

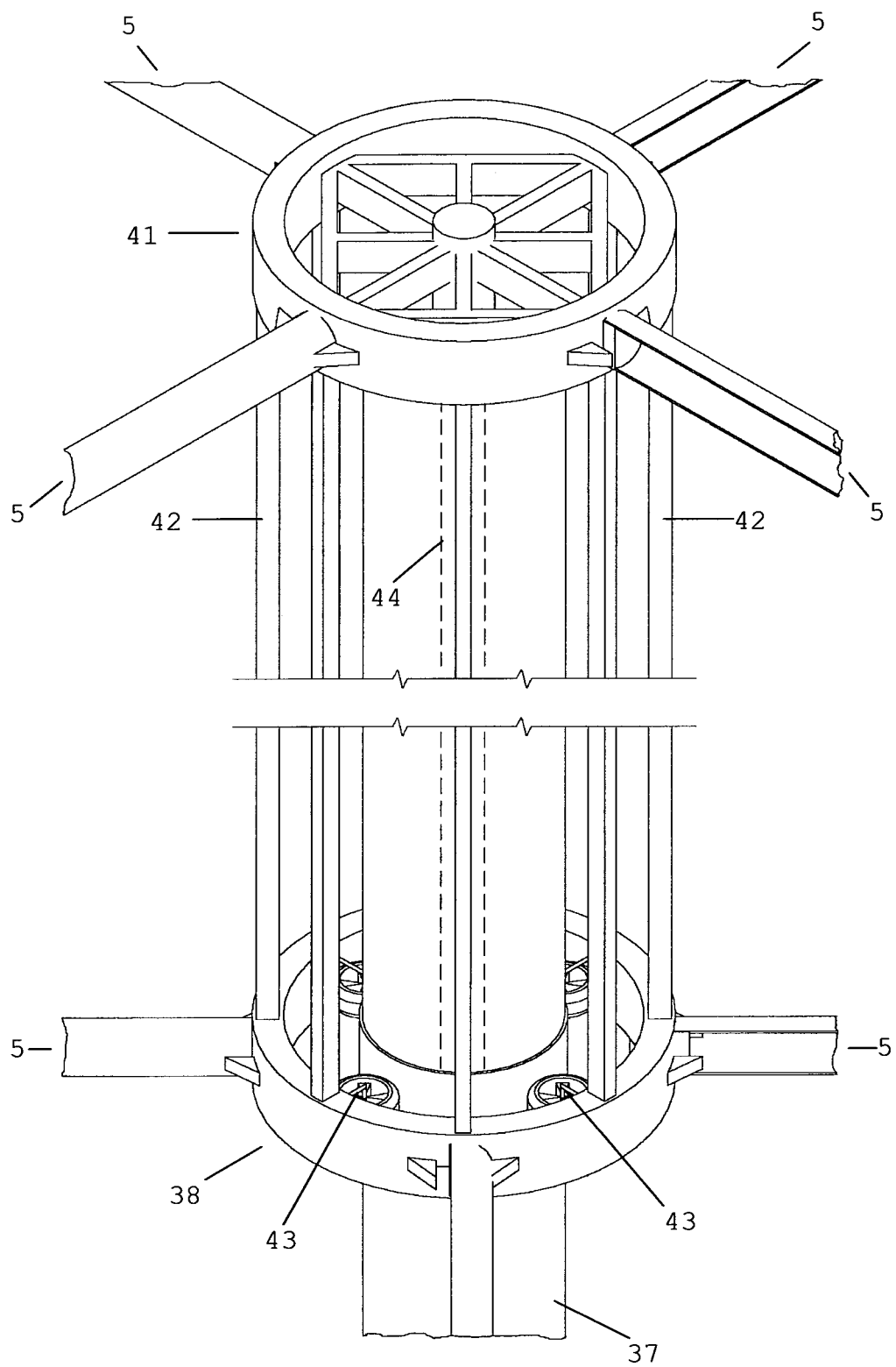

FIG. 47

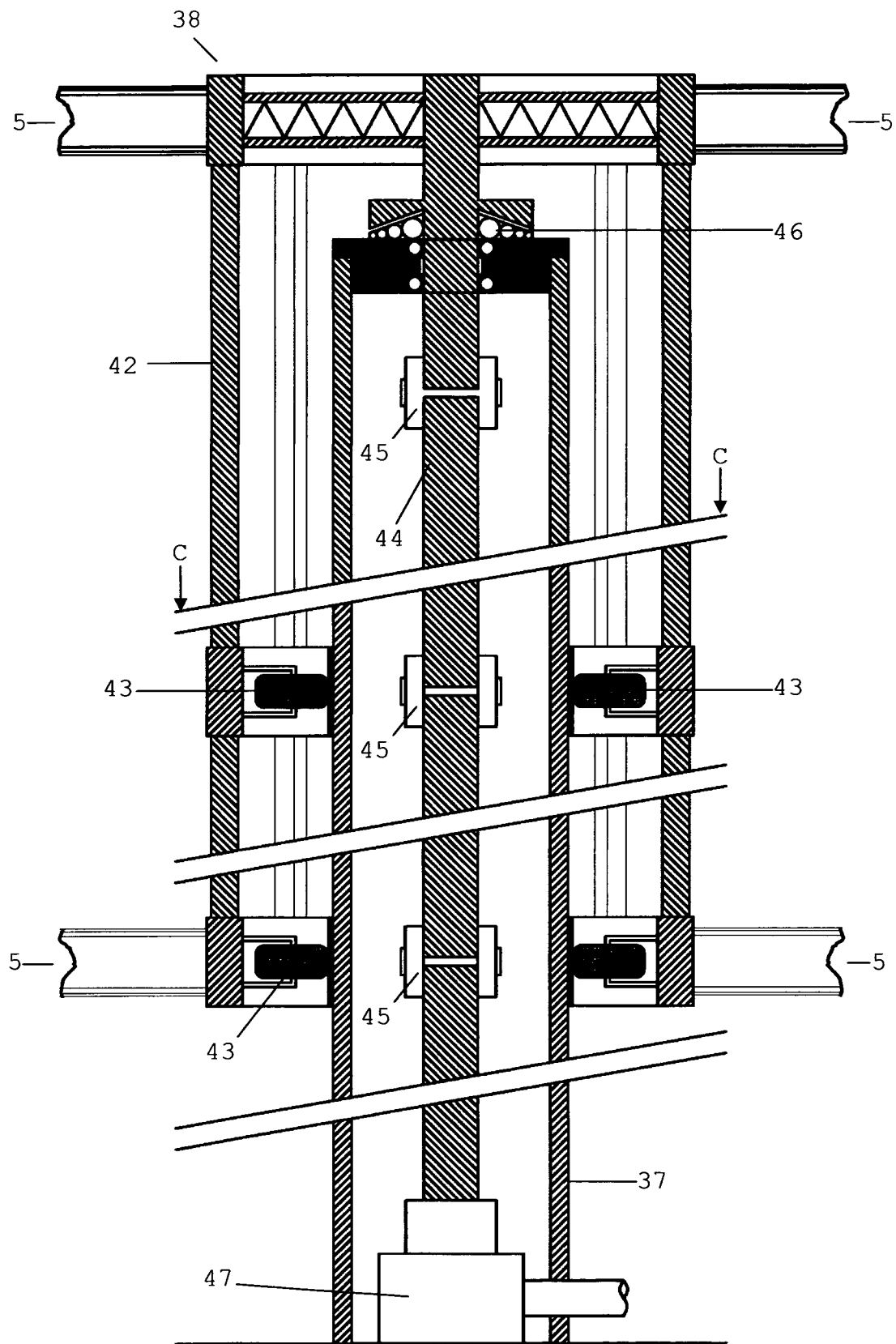

FIG. 48

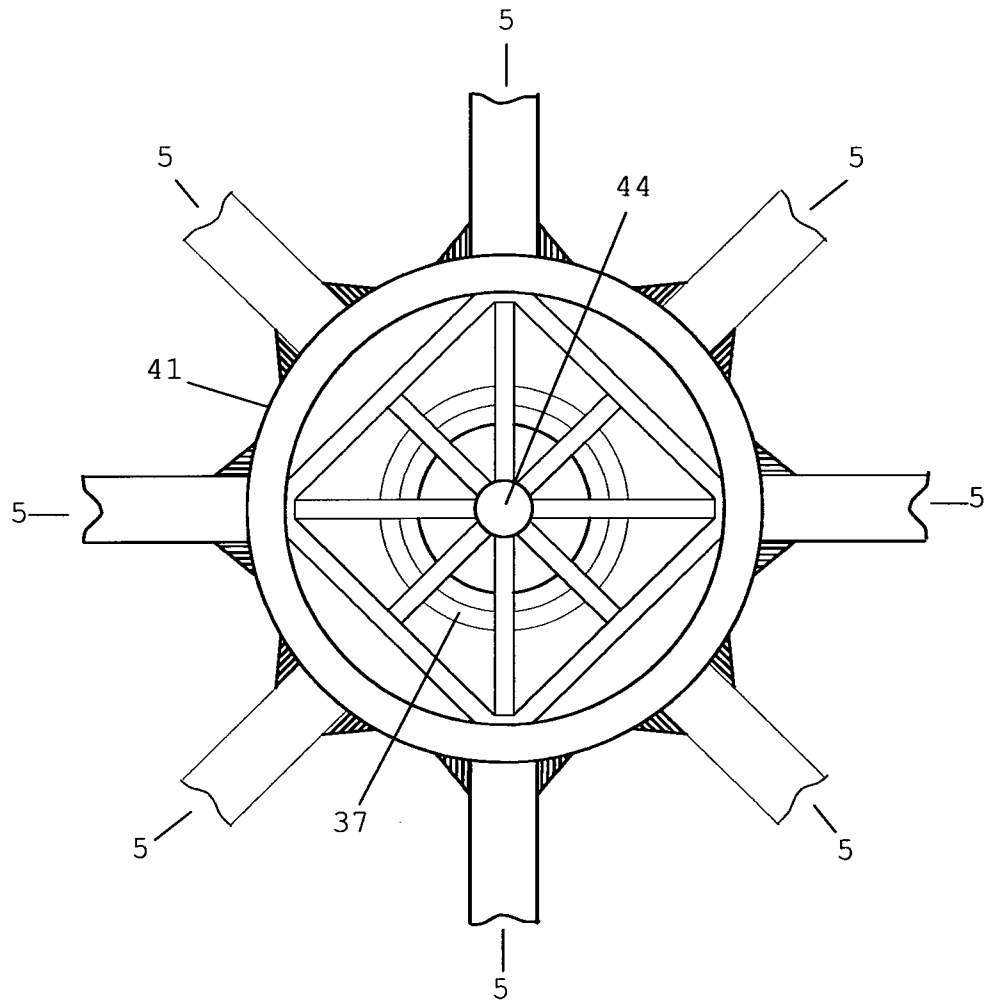

FIG. 49

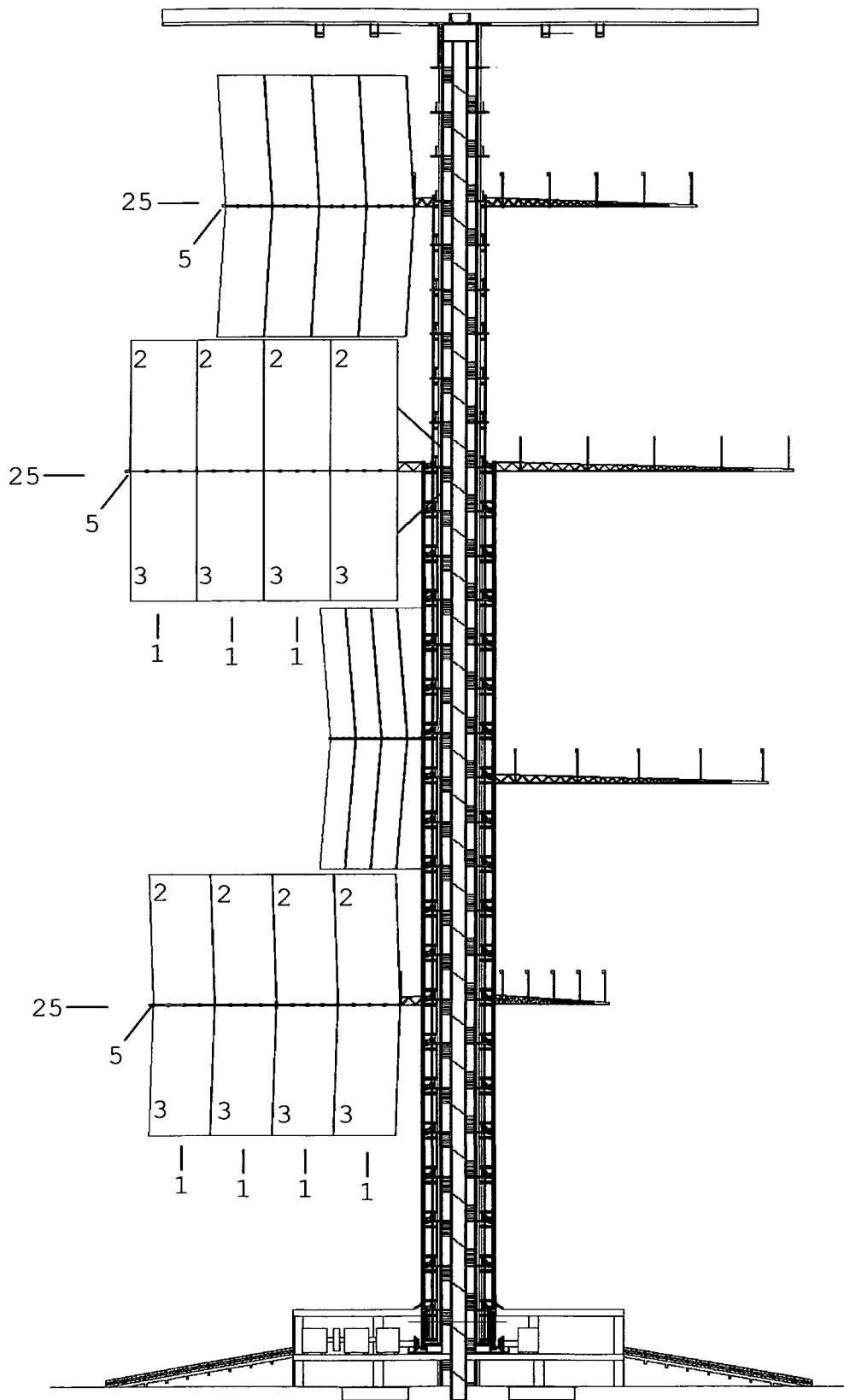

FIG. 50

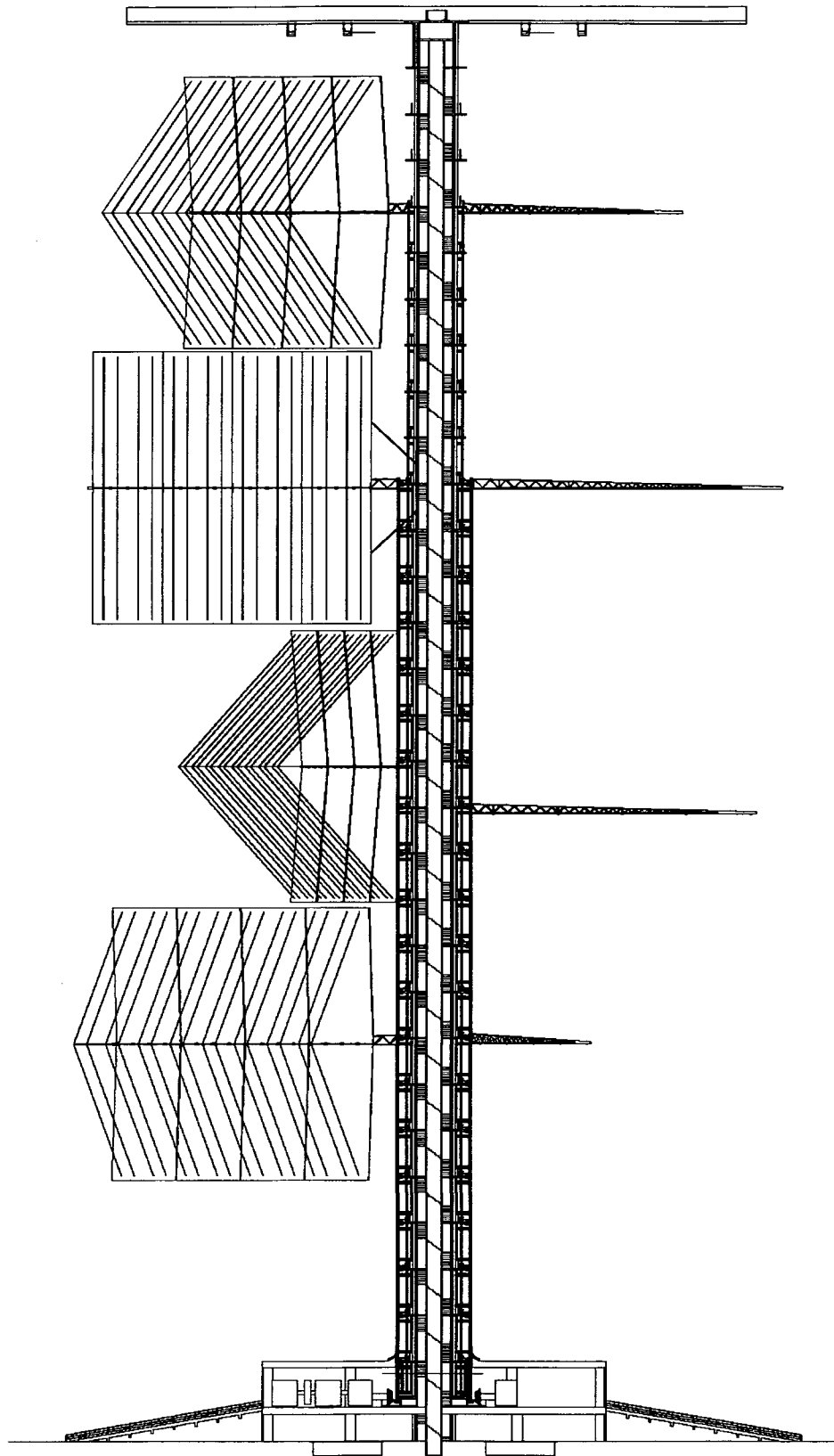

FIG. 51

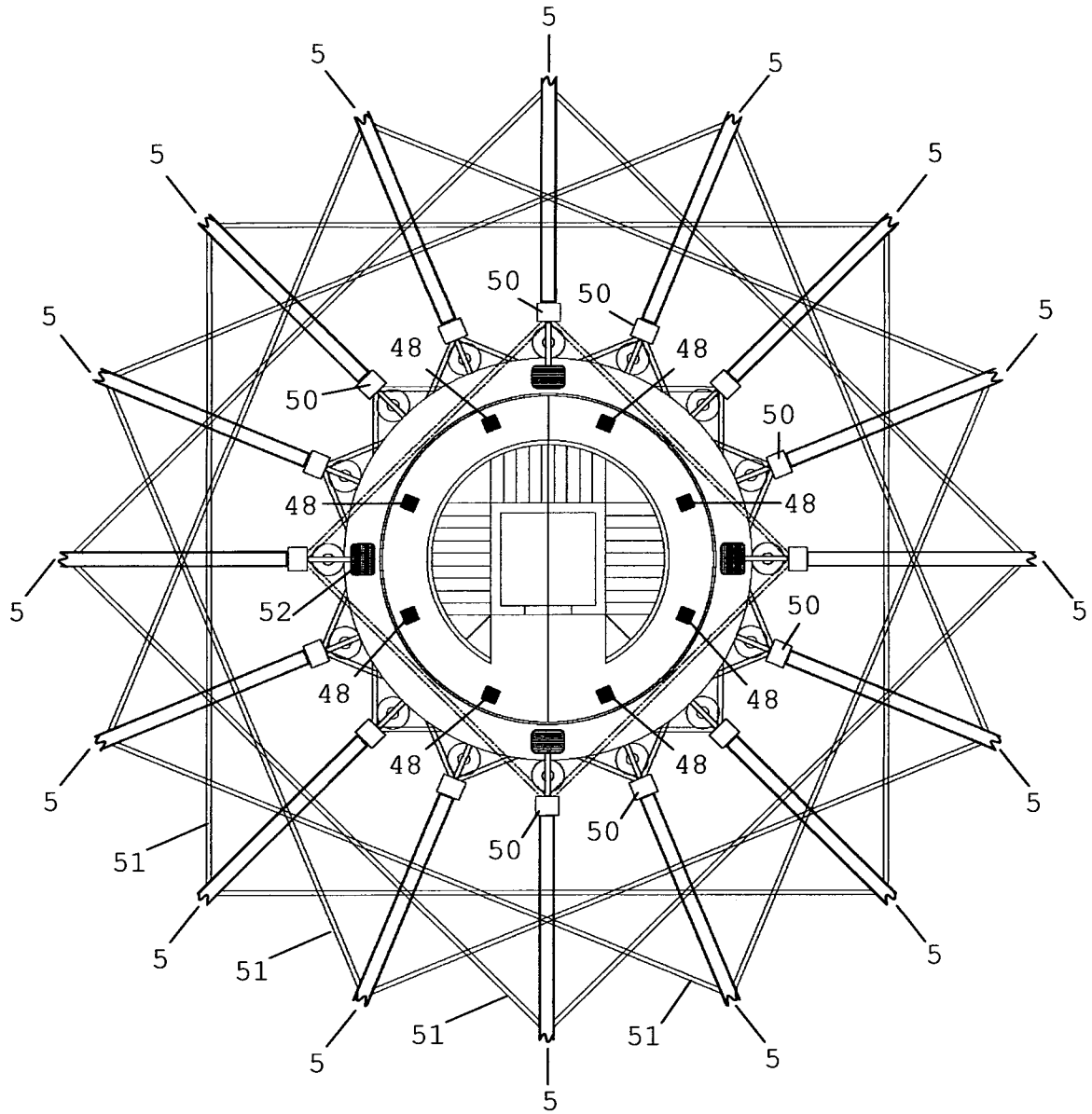

FIG. 52

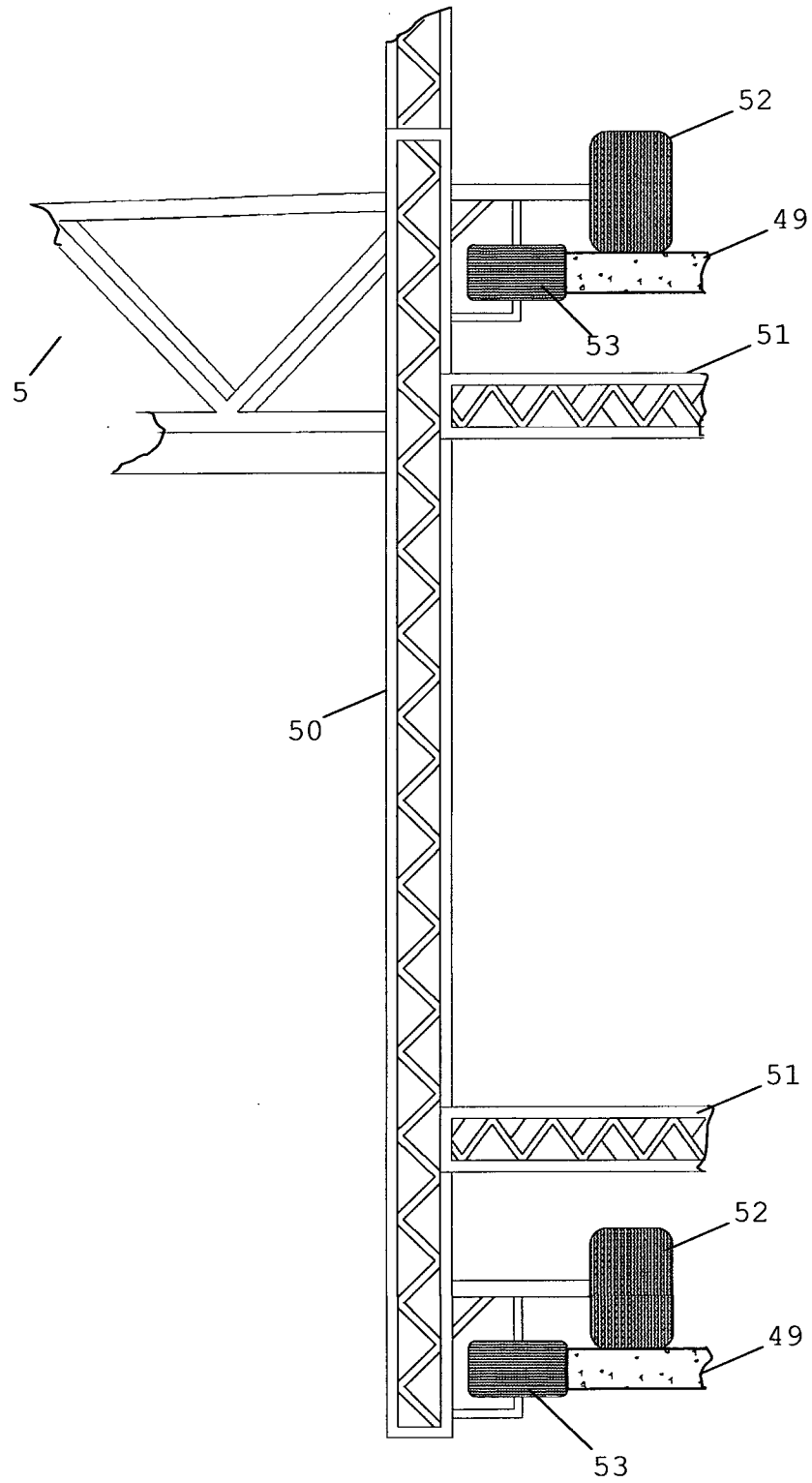

FIG. 53

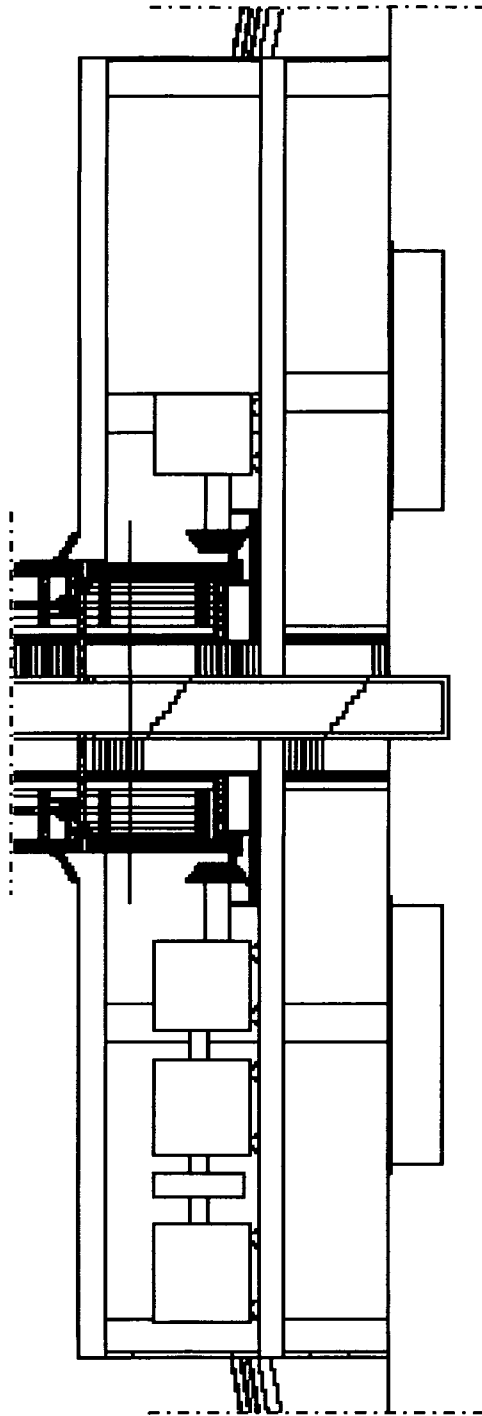

FIG. 54

INTERNATIONAL SEARCH REPORT

International application N°

PCT/BR2010/000200

A. CLASSIFICATION OF SUBJECT MATTER

IPC(2010.01) F03D 3/06, F03D 3/00

According to International Patent Classification (IPC) or to both national classification and IPC

B. FIELDS SEARCHED

Minimum documentation searched (classification system followed by classification symbols)

IPC(2010.01) F03D

Documentation searched other than minimum documentation to the extent that such documents are included in the fields searched

Base de dados do INPI (SINPI)

Electronic data base consulted during the international search (name of data base and, where practicable, search terms used)

EPODOC, USPTO

C. DOCUMENTS CONSIDERED TO BE RELEVANT

Category*	Citation of document, with indication, where appropriate, of the relevant passages	Relevant to claims N°
Y	CN 201351575 Y (SHANCHANG LI [CN]) 25 November 2009 (2009-11-25) Abstract; figures 1-18	1-3, 7-9, 14-17, 21
Y	WO 0233253 A2 (VATANDAS HASIM [TR]) 25 April 2002 (2002-04-25) the whole document	1-3, 7, 8, 14, 15, 21
Y	WO 2006136117 A1 (TAUS JAN [CZ]) 28 December 2006 (2006-12-28) Abstract; figures 1-4	1, 2, 14, 15, 21
Y	US 2004265127 A1 (NOBLE JAMES D [US]) 30 December 2004 (2004-12-30) Abstract; figures 1-6	1-3, 6-8, 14-16
A	US 2009066088 A1 12 March 2009 (2009-03-12) Abstract; figures 3	1, 2, 8, 9, 14, 15, 20

 Further documents are listed in the continuation of Box C. See patent family annex.

* Special categories of cited documents:

"A" document defining state of the art which is not considered to be of particular relevance

"E" earlier application or patent but published on or after the international filing date

"L" document which may throw doubts on priority claim(s) or which is cited to establish the publication date of another citation or other special reason (as specified)

"O" document referring to an oral disclosure, use, exhibition or other means

"P" document published prior to the international filing date but later than the priority claimed

"T" later document published after the international filing date or priority date and not in conflict with the application but cited to understand the principle or theory underlying the invention

"X" document of particular relevance; the claimed invention cannot be considered novel or cannot be considered to involve an inventive step when the document is taken alone

"Y" document of particular relevance; the claimed invention cannot be considered to involve an inventive step when the document is combined with one or more other such documents, such combination being obvious to a person skilled in the art

"&" document member of the same patent family

Date of the actual completion of the international search

10 December 2010

Date of mailing of the international search report

28 12 10

Name and mailing address of the ISA/BR



INSTITUTO NACIONAL DA
 PROPRIEDADE INDUSTRIAL
 Rua Mayrink Veiga nº 9, 18º andar
 cep: 20090-050, Centro - Rio de Janeiro/RJ
 Facsimile N°: +55 21 2139-3663

Authorized officer

Rodrigo Danieli

Telephone N°:

+55 21 2139-3686/3742

INTERNATIONAL SEARCH REPORT

International application N°

PCT/BR2010/000200

C. DOCUMENTS CONSIDERED TO BE RELEVANT

Category*	Citation of document, with indication, where appropriate, of the relevant passages	Relevant to claims N°
A	----- WO 2008003802 A1 (GARCIA GIRON ALFONSO [ES]) 10 January 2008 (2008-01-10) the whole document	1,3,7,8,14,15

INTERNATIONAL SEARCH REPORT

Information on patent family members

International application N°

PCT/BR2010/000200

Patent documents cited in search report	Publication date	Patent family members	Publication date
CN 201351575 Y	2009-11-25	None	
WO 0233253 A2	2002-04-25	AU 2431402 A EP 1339984 A2 WO 0233253 A3	2002-04-29 2003-09-03 2002-08-01
WO 2006136117 A1	2006-12-28	CZ 297478 B6 CZ 20050399 A3 EP 1896723 A1	2006-12-13 2006-12-13 2008-03-12
US 2004265127 A1	2004-12-30	AT 363596 T AU 2003258233 A1 BR 0313389 A CA 2491069 A1 CN 1675466 A CN 100347439 C DE 60314163 D1 EP 1546552 A1 ES 2287550 T3 JP 2005535824 T MX PA05001739 A NZ 538111 A US 2004001752 A1 US 6682302 B2 US 6929450 B2 WO 2004015266 A1 ZA 200500136 A	2007-06-15 2004-02-25 2005-06-21 2004-02-19 2005-09-28 2007-11-07 2007-07-12 2005-06-29 2007-12-16 2005-11-24 2005-04-19 2006-02-24 2004-01-01 2004-01-27 2005-08-16 2004-02-19 2005-11-01
US 2009066088 A1	2009-03-12	None	
WO 2008003802 A1	2008-01-10	ES 1063482 U	2006-11-01