

April 14, 1925.

1,533,443

A. MILLER

PIPE BENDING MACHINE

Filed May 21, 1924

3 Sheets-Sheet 1

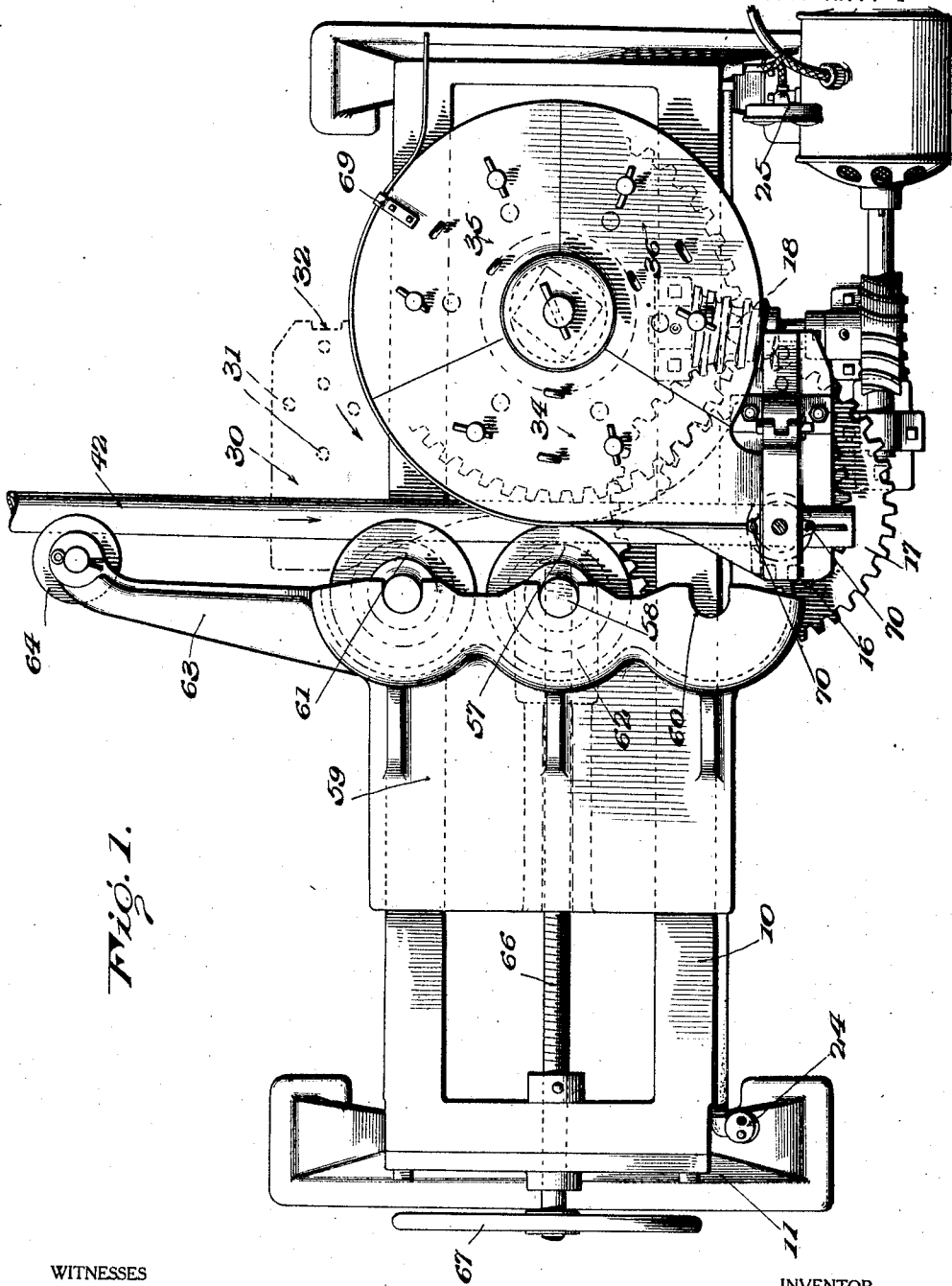

Fig. 1.

WITNESSES
W.A. Williams

INVENTOR
Andrew Miller
BY *Munro*
ATTORNEYS

April 14, 1925.

1,533,443

A. MILLER

PIPE BENDING MACHINE

Filed May 21, 1924

3 Sheets-Sheet 2

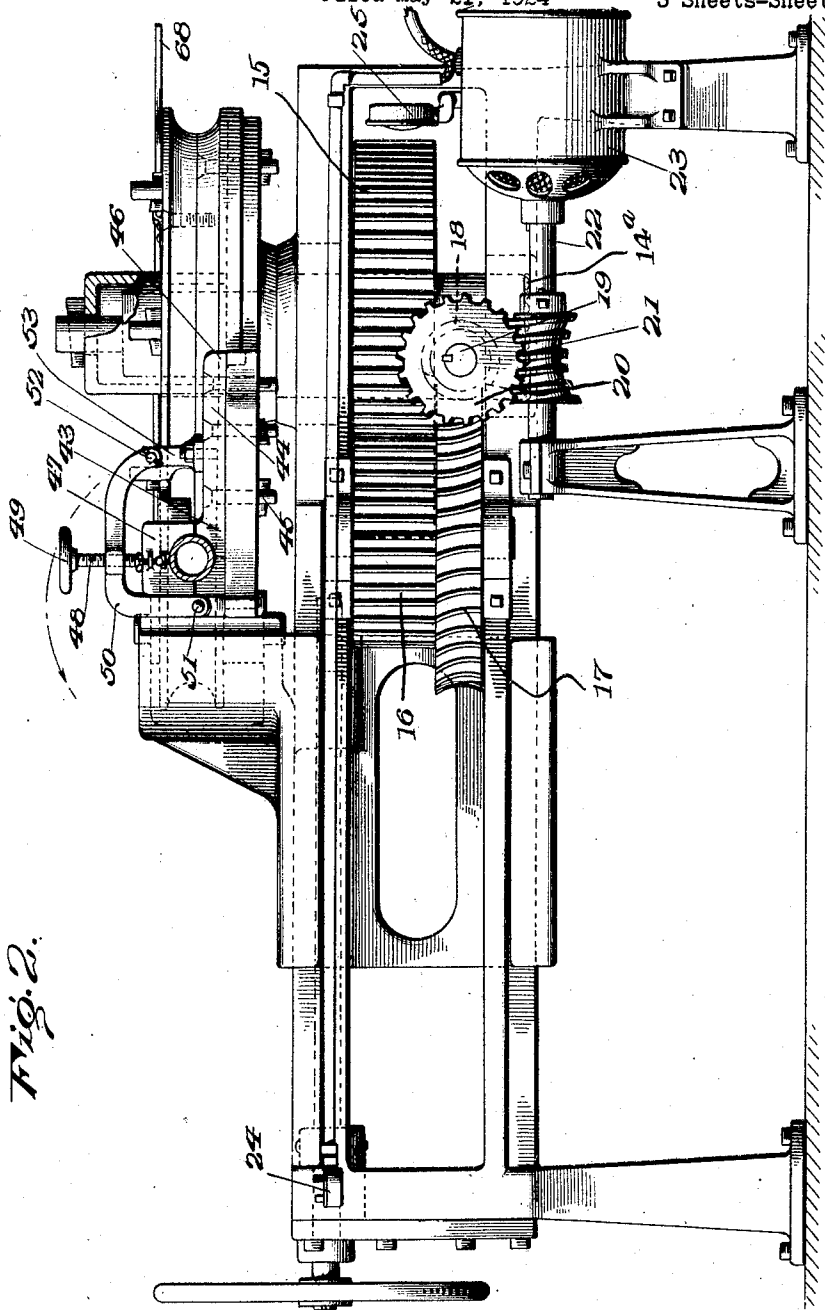

Fig. 2.

WITNESSES
W. A. Williams

INVENTOR
Andrew Miller
BY *Munn & Co*
ATTORNEYS

April 14, 1925.

1,533,443

A. MILLER

PIPE BENDING MACHINE

Filed May 21, 1924

3 Sheets-Sheet 3

Fig. 3.

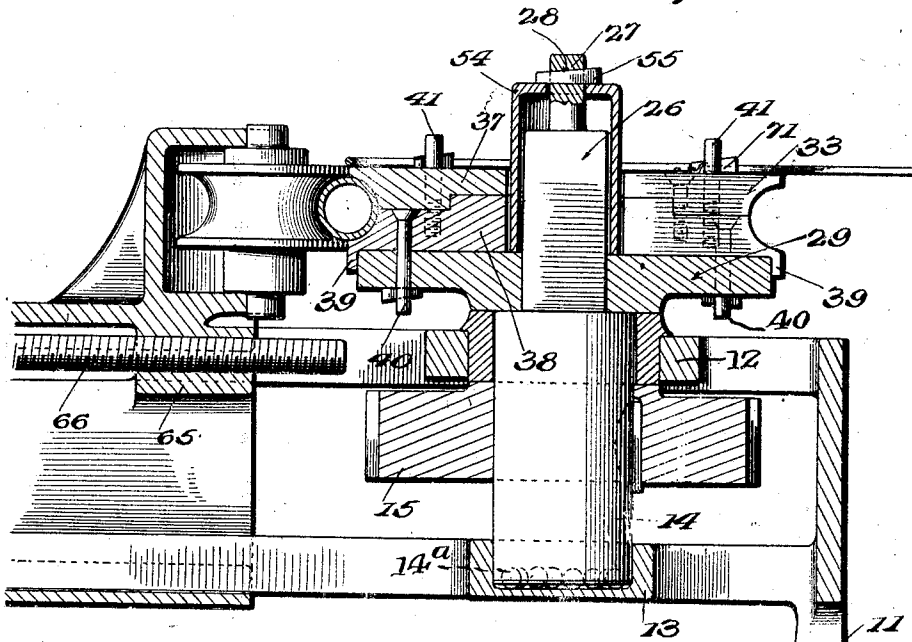

Fig. 4.

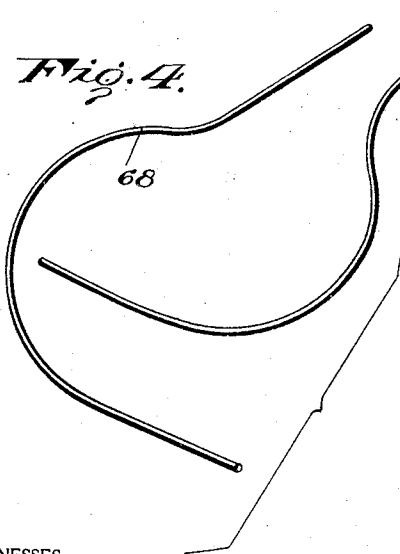
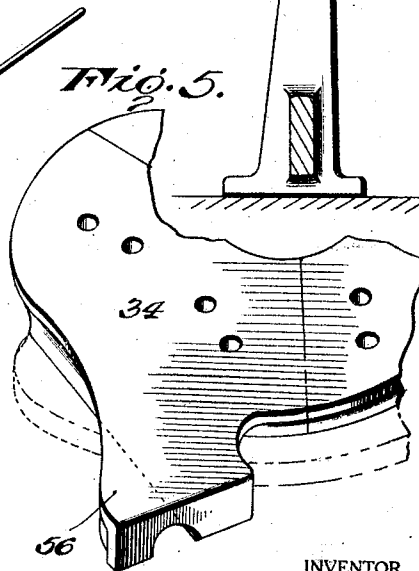

Fig. 5.



WITNESSES

W.A. Williams

INVENTOR

Andrew Miller

BY

Munroe
ATTORNEYS

UNITED STATES PATENT OFFICE.

ANDREW MILLER, OF NEWPORT NEWS, VIRGINIA.

PIPE-BENDING MACHINE.

Application filed May 21, 1924. Serial No. 714,850.

To all whom it may concern:

Be it known that I, ANDREW MILLER, a citizen of the United States, and a resident of Newport News, in the county of Warwick and State of Virginia, have invented certain new and useful Improvements in Pipe-Bending Machines, of which the following is a specification.

My present invention relates generally to pipe bending machines and especially such machines as are adapted to the bending of cold pipe of various sizes, the foremost and outstanding object of my invention being the provision of a machine which will be strong and durable as well as effective and efficient under the rough usage and severe strains to which it is necessarily subjected in practice.

A further object is the provision of a pipe bending machine especially constructed with a view to ready interchange of parts, as well as one which will uniformly and evenly bend cold pipe of various sizes and one which is especially adapted to the bending of pipe for the construction and reconditioning of ships.

Further objects and the resulting advantages of my invention will be better understood by reference to the following description thereof, in connection with the accompanying drawings which form a part of this specification, and in which—

Figure 1 is a top plan view of the complete machine.

Fig. 2 is a side elevation thereof,

Fig. 3 is an enlarged central longitudinal section taken partially through the machine,

Fig. 4 is a detail perspective view of a pair of templet or matrix rods, and

Fig. 5 is a perspective view of a portion of the bending member.

Referring now to these figures my invention proposes a machine whose body includes a rectangular bed plate 10 formed integral with and extending between upright end supports 11, the said bed plate having vertically spaced bearings at 12 and 13 adjacent to one end upright 11, for the rotatable support of a short vertical shaft 14 resting on anti-friction members 14^a in the lower bearing 13 and having upon its lower portion an enlarged spur gear 15.

The shaft 14, by virtue of rotation of which the bending operation is carried out, is preferably driven by virtue of the engagement of its gear wheel 15 by a smaller

gear 16 mounted in connection with a somewhat larger gear 17 the latter being a worm wheel engaged by a worm 18 upon the shaft 19 of which a worm wheel 20 is mounted and engaged by a second worm 21 secured upon the shaft 22 of a motor 23. This motor is preferably an electric motor susceptible of ready control from a switch indicated at 24 and located at the relatively opposite end of the frame with respect to the motor, the latter having a starting and stop signal 25 actuated when the switch 24 is manipulated so that the operator may be instantly aware that current has been cut on and cut off with respect to the motor.

The upper portion of the shaft 14, that is that portion projecting above the bed plate, is squared as at 26 and provided at the upper end of this squared portion with a reduced upright extension 27 having a transverse key slot 28 for a purpose which will be presently described. The squared portion 26 of the shaft receives thereon a bending member and this bending member includes a base plate 29, which is circular for the most part and provided at opposite sides with similar outstanding flat clamp supporting extensions 30, each provided with a series of bolt receiving apertures 31 and a recess 32.

The bending member also includes a bending wheel generally indicated at 33 consisting of three segments 34, 35 and 36 as shown in Fig. 1, the wheel as a whole being in upper and lower sections 37 and 38 as shown in Fig. 3, of which the lower section 38 has depending flanges 39 extending downwardly around the base plate 29 except of course for the clamp supporting extensions 30 of the latter. The lower section 38 of the bending wheel is securely fastened to the base plate 29 by means of bolts 40 and is furthermore provided with upstanding bolts 41 for the connection of the upper section 37 to the lower section 38, it being of course understood that the segments 34, 35 and 36 are independently connected in place and that either one, two or all of the segments may be utilized depending upon the character of the bend to be imparted to the pipe, for instance the pipe 42.

The bending wheel 33 has a peripheral groove in which the pipe is partially seated when it is initially extended as seen in Figure 1 against the bending wheel at one point and across the base plate extensions 30, the

free end of the pipe being extended into a vise including a body block 43 whose extension 44, as best seen in Figs. 1 and 2, is secured to one of the base plate extensions 30 by means of bolts 45 extending through the base plate apertures 30 and whose body is provided at one end with an angular depending lug 46 adapted to extend into the recess 32 of the extension plate. The body 43 of the vise has a concave seat for the reception of the pipe, the latter of which is clamped by a clamping block 47 pressed downwardly into engagement therewith by virtue of an operating screw 48 whose lower end has a swivel connection with the block 47 and whose upper end has a hand wheel 49. This screw works through a frame 50 hingedly connected at one end as at 51 to the body 43 and provided at its opposite end with a detachable pinned connection at 52 to a bracket 53 of the vise body, it being thus obvious that the vise may be readily changed from one extension 30 of the base plate 29 of the bending member to the other, depending upon whether a right or left hand bend of the pipe is desired.

The segments 34, 35 and 36 of the bending wheel are rotated by virtue of their connection to one another and to the base plate 29 and do not at their centers fit the squared portion of the shaft, these segments forming a cylindrical opening at their center around the shaft for the reception of a sleeve 54 shown in Fig. 3 whose lower annular edge rests on the base plate 29 and whose upper end has an opening around the reduced upper shaft extension 27 so that a key 55 may be extended through the slot 28 of the said extension and, by its pressure upon the upper end of the sleeve 54, thus hold the base plate 29 and consequently the bending wheel downwardly in position around the shaft.

In action the vise is braced by an extension 56 of one of the bending wheel segments, in the present instance the segment 34, this extension 56 being an integral part of the upper section 37 of said segment 34 and being shaped to abut the inner face of the vise as shown in Fig. 1 in order to brace the vise when pull is exerted on the pipe in the bending operation.

Opposite the point of contact of the pipe 42 to be bent with the grooved bending wheel, the pipe is engaged by a grooved pressure roller 57 having its trunnions 58 disposed in the central bearings of a pressure roller frame generally indicated at 59, the pressure roller 57 being disposed between similar bearings 60 of the frame into either of which a roller 61 may be placed so that this roller will engage the pipe to be bent at one side of the pressure roller 57, depending upon the direction in which the bending takes place. The frame has a portion 62 which partially houses the rollers 57 and 61

and also has a portion which slides on the bed plate 10 toward and away from the bending wheel. Moreover the frame 59 has an extension arm 63 at one side provided with a roller 64 engaging the pipe to be bent and acting as a guide therefor and also has a central depending threaded portion 65 as seen in Fig. 3 through which the inner end of an adjusting screw 66 extends. This adjusting screw 66 is mounted centrally and longitudinally of the bed plate 10 and through the end of the main supporting frame of the machine opposite to that adjacent to which the bending member is mounted, the outer end of the adjusting screw 66 having a hand wheel 67.

It is obvious of course that in the use of the machine the segments of the bending wheel must be changed for different sizes of pipes, and this is true of the pressure and guide rollers and also the segments must be interchanged for the proper bracing support of the vise in its two positions. It is quite apparent that when the pipe is placed within the bending machine as in Fig. 1 and clamped at one side of the portion to be bent, within the pipe holding vise, rotation of the parts, upon the starting of the motor 23, will draw the pipe around to the desired bend between the bending wheel and the pressure roller 57, the pipe being thus engaged at constantly changing points so that the bending thereof is even and uniform and the operation may be instantly started and stopped by means of the switch 24 at the operator's station of the machine.

Templet or matrix rods 68 as seen in Fig. 4 may be used in connection with my improved bending machine to indicate the extent of rotary movement of the bending wheel necessary to produce the desired shape, the bending wheel having a clamp 69 as shown in Fig. 1 to engage a portion of such a templet rod, whose free end is extended through the clamping block 47 of the vise as seen in Fig. 2 and engaged by set screws 70 seen in Fig. 1, so that the rod will be alined above the center of the pipe at that point where the pipe is engaged by the bending wheel and the pressure roller 57.

The several bolts 40 and 41 securing the bending wheel segments to one another and to the base plate 29 of the bending member are preferably secured by keys 71 so as to avoid the delays incident to rusting nuts and the like and facilitate interchange of these parts for different sizes of pipe, and it is thus apparent that in addition to great strength and durability, my improved bending machine lends itself to ready, quick manipulation and, by virtue of its adaptability to right and left hand bends, is capable of bending all but a very small percentage of the pipe utilized in the building and reconditioning of ships.

I claim:

1. In a pipe bending machine, a frame, a driven shaft journaled vertically in the frame and having a squared upper portion, a bending member on the squared portion of the shaft including a base plate fitting the square shaft and having outstanding vise holding extensions, a pipe clamping vise similarly engageable with either of said extensions, said pipe bending member also including a wheel in segments detachably connected to the said base plate and each segment in upper and lower sections detachably connected to one another, the inner portions of the segments forming a cylindrical opening around the square shaft, a sleeve around the square shaft within said opening and having its lower end engaging the base plate, said square shaft having an upstanding extension projecting through the top of the sleeve, and means engaging the said extension of the shaft and bearing on the upper end of the sleeve for the purpose described.

2. In a pipe bending machine, a frame, a driven shaft journaled vertically in the frame and having a squared upper portion, a bending member on the squared portion of the shaft including a base plate fitting the square shaft and having outstanding vise holding extensions, a pipe clamping vise similarly engageable with either of said extensions, said pipe bending member also including a wheel in segments detachably connected to the said base plate and each segment in upper and lower sections detachably connected to one another, the inner portions of the segments forming a cylindrical opening around the square shaft, a sleeve around the square shaft within said opening and having its lower end engaging the base plate, said square shaft having an upstanding extension projecting through the top of the sleeve, and means engaging the said extension of the shaft and bearing on the upper end of the sleeve, the upper section of one of said segments of the bending wheel having an angular extension engaging the vise and forming a brace for the latter.

3. In a pipe bending machine, a frame, a driven shaft journaled vertically in the frame and having a squared upper portion, a bending member on the squared portion of the shaft including a base plate fitting the square shaft and having outstanding vise holding extensions, a pipe clamping

vise similarly engageable with either of said extensions, said pipe bending member also including a wheel in segments detachably connected to the said base plate and each segment in upper and lower sections detachably connected to one another, the inner portions of the segments forming a cylindrical opening around the square shaft, a sleeve around the square shaft within said opening and having its lower end engaging the base plate, said square shaft having an upstanding extension projecting through the top of the sleeve, and means engaging the said extension of the shaft and bearing on the upper end of the sleeve, the upper section of one of said segments of the bending wheel having an angular extension engaging the vise and forming a brace for the latter, and the lower sections of said segments having flanges depending around and engaging the peripheral portion of the base plate for the purpose described.

4. In a pipe bending machine, a bending member including a base plate having similar oppositely disposed supporting extensions, a vise similarly attachable to either of said extensions for right and left pipe bends, a series of segments forming a bending wheel around and secured to the said base plate, a shaft on which the base plate is mounted, and means to rotate said shaft, one of said bending wheel segments having an angularly outstanding extension engaging the vise and forming a bracing support therefor.

5. In a pipe bending machine, a bending member including a base plate having similar oppositely disposed supporting extensions, each provided with openings and a recessed portion, a vise similarly attachable to either of said extensions through the openings thereof and having an angular portion extendible into the recess thereof, a series of segments forming a bending wheel, each of said segments having upper and lower sections, the former secured to the latter and the latter secured to the said base plate, and the upper section of one of said segments having an angularly outstanding brace engaging the vise in its effective position, and a driven shaft mounted vertically in the frame, on a portion of which the said base plate and bending wheel are mounted and with which the said base plate is engaged to rotate with the shaft as and for the purpose set forth.

ANDREW MILLER.