



(19) **United States**

(12) **Patent Application Publication**
WITTMAIER

(10) **Pub. No.: US 2002/0031982 A1**

(43) **Pub. Date: Mar. 14, 2002**

(54) **DEVICE FOR ROTATIONAL CUTTING OF BAND-SHAPED MATERIAL**

(30) **Foreign Application Priority Data**

Jan. 16, 1997 (DE)..... 29700627.4

(76) Inventor: **KLAUS WITTMAIER, VAHINGEN (DE)**

Publication Classification

(51) **Int. Cl.⁷ B24B 9/00**

(52) **U.S. Cl. 451/21; 451/424**

(57)

ABSTRACT

The invention relates to a device for rotational cutting of band-shaped material, comprising a rotational cutting cylinder which is fitted with at least one cutting edge and a counter-tool, wherein the band-shaped material is passed between the counter-tool and the rotational cutting roller. The rotational cutting roller is fitted with at least one, and specially two thrust collars placed in the circumference of the counter-tool, which determine the feed motion of the cutting edge towards the counter-tool. According to the invention, at least one sharpening device having at least one sharpening element is provided, which can be placed on the thrust collar or collars or on the counter-tool, said sharpening element removing material from the thrust collars or the counter-tool.

Correspondence Address:

**FELIX J D'AMBROSIO
JONES TULLAR & COOPER
PO BOX 2266 EADS STATION
ARLINGTON, VA 22202**

(*) Notice: This is a publication of a continued prosecution application (CPA) filed under 37 CFR 1.53(d).

(21) Appl. No.: **09/269,202**

(22) PCT Filed: **Jan. 13, 1998**

(86) PCT No.: **PCT/EP98/00148**

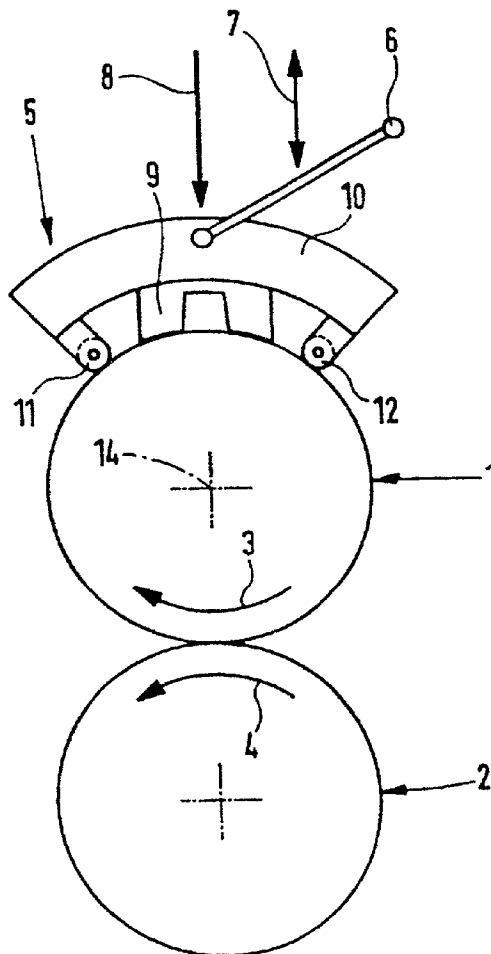

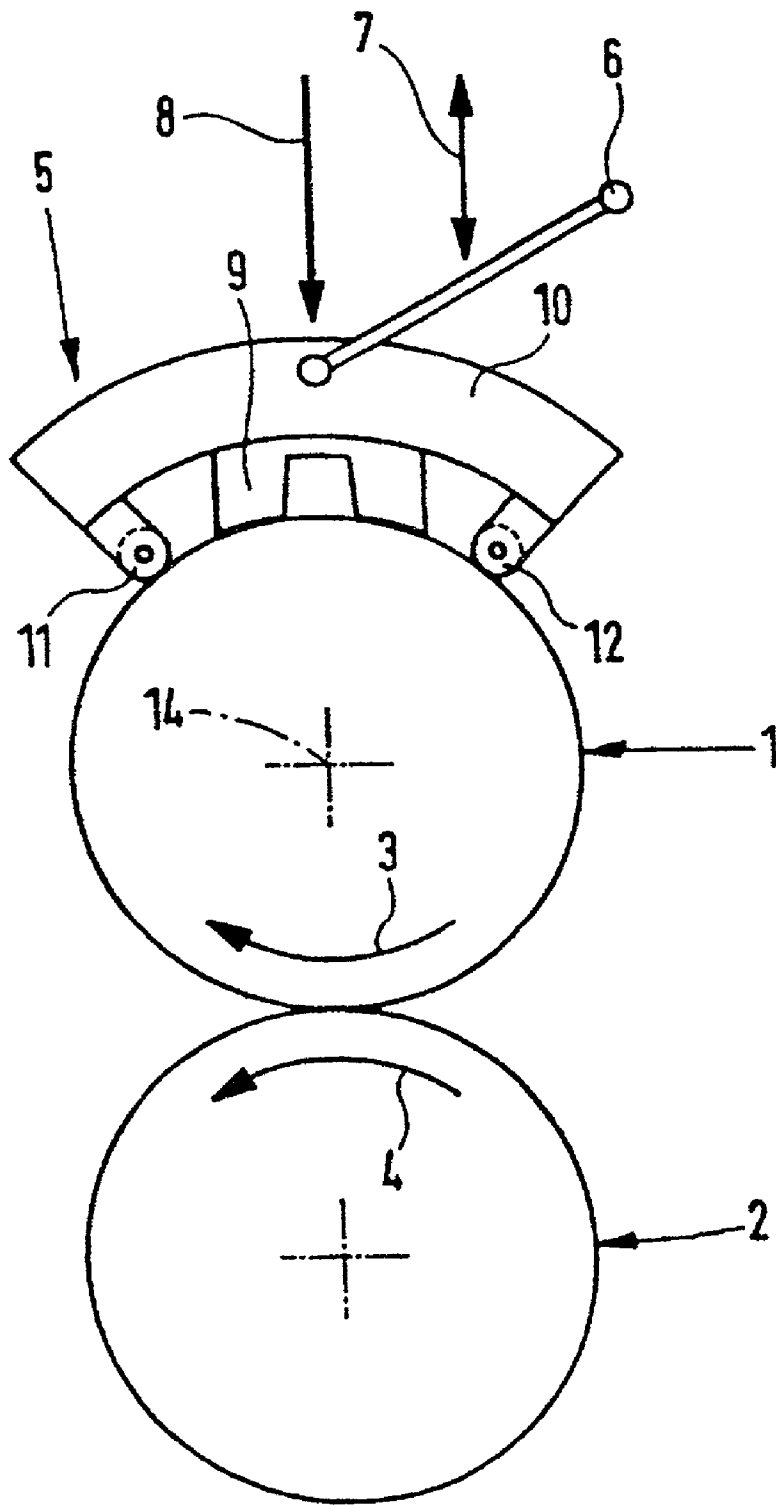
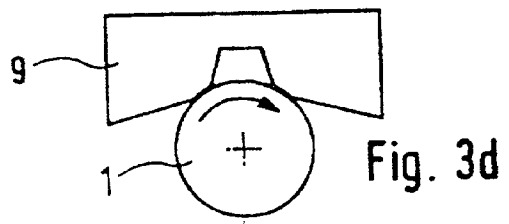
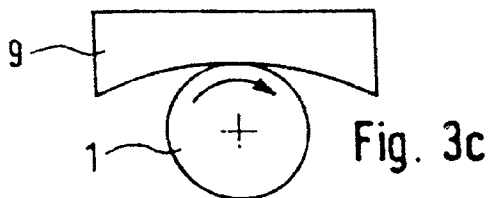
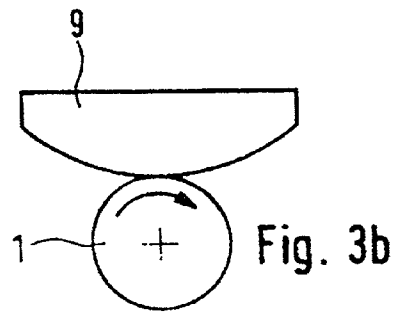
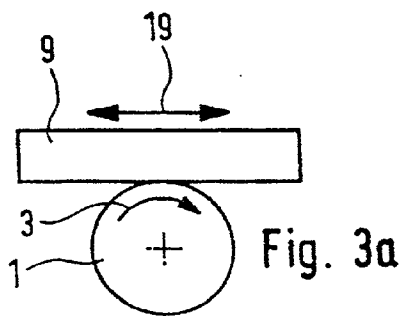
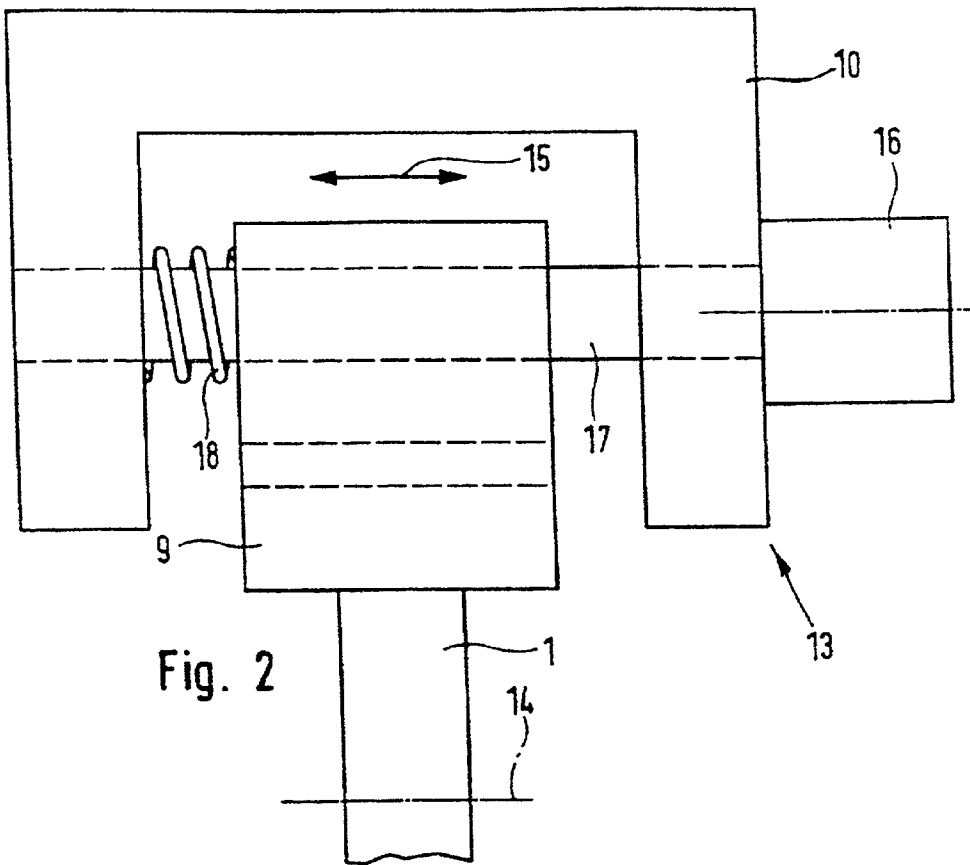

Fig. 1



DEVICE FOR ROTATIONAL CUTTING OF BAND-SHAPED MATERIAL

[0001] The invention relates to a method for rotary cutting of band-shaped material in accordance with the preamble of claim 1.

[0002] As a rule, such devices have a rotary cutting roller having at least one cutter on its exterior surface, by means of which the band-shaped material is cut. Here, the band-shaped material runs through a gap between the rotary cutting roller and a counter-tool. Advancing the cutter in the direction toward the counter-tool takes place by means of barrel rings, which customarily are provided on the rotary cutting roller. In this case the cutter can slightly project past the exterior circumference of these barrel rings, can terminate flush with them, or can be slightly set back from them. This is a function of the respective band-shaped material to be cut.

[0003] The cutters wear in the course of the cutting process, so that the distance between the cutter tips and the counter-tool increases. This leads to worsening of the cutting effect. It is now known from the prior art to set the gap back to the desired value by increasing the contact pressure force of the barrel rings on the counter-cylinder. This can be performed relatively simply. However, very high forces are required, and the entire cutting device is heated more because of deformation. Moreover, this method has its limits, since it is not possible to advance to the desired extent. In addition, this method is very sensitive to dirt.

[0004] In addition it is known to use conical bearer rings for axially displacing the rotary cutting roller in relation to the counter-tool. This adjustment method is relatively expensive and elaborate, and here, too, relatively great warming occurs on the contact points of the bearer rings. This method is also sensitive to dirt, and advancing is limited.

[0005] It is furthermore known to provide the counter-tool with barrel rings having a conical interior surface, which are seated on a cone of the counter-tool. The diameter of these barrel rings can be reduced by appropriate prestressing. Here, too, the outlay for mounting is great and expensive. Such barrel rings are furthermore prone to break.

[0006] It is the object of the invention to further develop a device of the type mentioned at the outset in such a way that the gap, which was changed because of the wear on the cutter, can be relatively easily readjusted.

[0007] This object is attained in accordance with the invention by the features of the characterizing portion of claim 1.

[0008] The distance between the rotary cutting roller and the counter-tool decreases because of the wear of the barrel rings, and by means of this the cutter is advanced. This is relatively easily possible in that the grinding element is placed on the barrel rings or the counter-tool and material is removed until the desired distance between the cutter and the counter-tool, or respectively the desired narrow gap, has again been reached.

[0009] The grinding device in accordance with the invention is employed during the normal cutting process and when needed. The device can be pivoted out and/or brought into contact mechanically, pneumatically and/or hydraulically.

Grinding time can be selected to be as long as desired and can also be set. Furthermore, the contact pressure, and therefore the rate of removal, can be freely selected and set. The grinding element of the grinding device can be matched to the barrel ring. During the grinding process, the grinding element or the complete grinding device can be oscillatingly moved transversely to the direction of rotation by means of springs and pneumatic assistance, so that even removal occurs. Depending on the requirements, the grinding element can be broader or narrower than the barrel ring. Cleaning rollers can be placed ahead or behind, which pick up dust and dirt. Cleaning can also be performed by fixed lips or strippers, and a cleaning additive or grinding agent can be added. Moreover, depending on the requirements, the device can be placed, or respectively pivoted in, with or against the direction of rotation of the barrel ring. If the grinding process is performed on the counter-cylinder, then as a rule in the areas where the barrel rings are seated. Because of the pivot device, the device is independent of the diameters of the rollers. Another stripper, for example a blade stripper, can be placed ahead of or behind the cleaning elements. The grinding element can also be composed of several different grinding materials, for example as a compound grinding element, or respectively a sandwich grinding element. The shape of the grinding element can be arbitrary, for example, flat, curved, concave, convex or prism-shaped. If heat is generated in an undesirable manner during the grinding or polishing process, a compressed air nozzle can be attached to the grinding device for cooling the barrel ring. If necessary for the result of grinding, the grinding device can be moved in or against the running direction of the barrel ring in addition to the transverse movement or independently thereof. Moreover, the contact pressure can be set at different strengths, or it can be additionally supplied in a pulsed manner.

[0010] Further advantages, characteristics and details of the invention ensue from the dependent claims and the following description, wherein exemplary embodiments are represented in detail, making reference to the drawings. Shown here are in:

[0011] **FIG. 1**, a schematic representation of the grinding device in accordance with the invention,

[0012] **FIG. 2**, a schematic representation of an oscillating device for a grinding element;

[0013] **FIGS. 3a to 3d**, different shapes of the grinding element.

[0014] A barrel ring **1** of a rotary cutting cylinder and a counter-tool **2** are represented in **FIG. 1**. Both the barrel ring **1** and the counter-tool **2** rotate in the direction of the arrows **3** and **4**. A grinding device, identified as a whole by **5**, is provided on the top of the barrel ring **1**. This grinding device is seated, pivotable in the direction of the two-headed arrow **7**, in a bearing **6**. Moreover, the grinding device **5** is charged with a pressure force in the direction of the arrow **8** by means of a suitable device and is pressed on the exterior surface of the barrel ring **1** in this way. In this case a grinding element **9**, which is interchangeably provided in a housing **10** of the grinding device **5**, rests on the grinding ring **1**. Cleaning pods **11** and **12** are provided ahead of and behind the grinding element **9**, which clean and, if required moisten, the surface of the barrel ring **1**.

[0015] An oscillating device **13** is represented in **FIG. 2**, by means of which the grinding element **9** is oscillatingly

moved in the direction of the axis **14** of the barrel ring, and therefore in the direction of the two-headed arrow **15**. The grinding element **9** is here driven by a mechanical, hydraulic or pneumatic drive **16**, for example a cylinder or the like. A drive rod **17** here acts directly on the grinding element **9**, while the grinding element **9** is supported on the opposite side on a spring **18** (helical compression spring).

[0016] Different shapes of the grinding element **9** are represented in **FIGS. 3a to 3d**. **FIG. 3a** shows a grinding element **9** with a level grinding surface, wherein the grinding element **9** furthermore can be moved oscillatingly in the direction of the two-headed arrow **19**, i.e. in the direction of rotation (arrow **3**) of the barrel ring **1** and opposite this direction of rotation. **FIG. 3b** shows a grinding element **9** with an arch-shaped convex grinding surface, and **FIG. 3c** shows a grinding element **9** with an arch-shaped concave grinding surface. **FIG. 3d** shows a grinding element **9** with a prismatic (V-shaped) grinding surface.

1. A device for rotary grinding of band-shaped materials, having a rotary cutting roller which has at least one cutter on its exterior surface, and a counter-tool (**2**), wherein the band-shaped material is passed between the counter-tool (**2**) and the rotary cutting roller, wherein the rotary cutting roller has at least one, in particular two barrel rings (**1**), which rest against the circumference of the counter-tool (**2**), and by means of which the advance of the cutter toward the counter-tool (**2**) can be determined, characterized in that at least one grinding device (**5**) with at least one grinding element (**9**) is provided, which can be placed on the, or respectively the barrel rings (**1**) or the counter tool (**2**), and with which material can be removed from the barrel rings (**1**) or from the counter-tool (**2**).

2. The device in accordance with claim 1, characterized in that the grinding device (**5**) can be pivoted on the, or respectively the barrel rings (**1**).

3. The device in accordance with one of the preceding claims, characterized in that the grinding device (**5**) can be placed during the cutting process.

4. The device in accordance with one of the preceding claims, characterized in that in case of need, the grinding device (**5**) can be placed manually or automatically.

5. The device in accordance with one of the preceding claims, characterized in that the grinding device (**5**) can be placed and/or brought into contact mechanically, pneumatically and/or hydraulically.

6. The device in accordance with one of the preceding claims, characterized in that the length of grinding can be freely selected and set.

7. The device in accordance with one of the preceding claims, characterized in that the contact pressure can be freely selected and, in particular, is pulsating.

8. The device in accordance with one of the preceding claims, characterized in that the grinding elements (**9**) are matched to the barrel ring (**1**), or respectively the counter-tool (**2**), and in particular have a sandwich construction.

9. The device in accordance with one of the preceding claims, characterized in that the grinding device (**5**) or the grinding element (**9**) can be oscillatingly moved transversely in relation to the rotating direction of the workpiece.

10. The device in accordance with one of the preceding claims, characterized in that the grinding element (**9**) is wider or narrower than the barrel ring (**1**).

11. The device in accordance with one of the preceding claims, characterized in that the grinding device (**5**) has stripper and/or cleaning elements, in particular roller (**11**, **12**) or blades, which have been placed ahead of and/or behind the grinding element (**9**).

12. The device in accordance with claim 11, characterized in that the cleaning elements moisten the grinding spot.

13. The device in accordance with one of the preceding claims, characterized in that the grinding device (**5**) can be pivoted into or counter to the running direction of the barrel rings (**1**) or of the counter-tool (**2**).

14. The device in accordance with one of the preceding claims, characterized in that the grinding device (**5**) is independent of the diameter of the barrel rings (**1**) or the counter-tool (**2**).

15. The device in accordance with one of the preceding claims, characterized in that the shape of the grinding element (**9**) is flat, convex, concave or prism-shaped.

16. The device in accordance with one of the preceding claims, characterized in that a cooling device, which cools the grinding spot, for example a compressed air nozzle, is provided.

17. The device in accordance with one of the preceding claims, characterized in that the grinding device (**5**) can be oscillatingly moved in or counter to the direction of rotation.

* * * * *