



US007850327B2

(12) **United States Patent**
Campbell et al.

(10) **Patent No.:** **US 7,850,327 B2**
(45) **Date of Patent:** **Dec. 14, 2010**

- (54) **APPARATUS, LOGIC AND METHOD FOR EMULATING THE LIGHTING EFFECT OF A CANDLE** 2,435,811 A 2/1948 Waters
- 2,509,219 A 4/1948 Desmond et al.
- 3,749,904 A 7/1973 Graff
- 3,761,702 A 9/1973 Andeweg
- (75) Inventors: **Kurt Campbell**, Cambridge, MA (US); 3,762,857 A 10/1973 Andeweg
- Mike Boone**, Los Angeles, CA (US); 3,890,085 A 6/1975 Andeweg
- Mark Medley**, Covina, CA (US); **Karel Slovacsek**, Irvine, CA (US) 4,159,442 A 6/1979 Komatsu
- 4,218,727 A 8/1980 Shemitz et al.
- 4,260,365 A 4/1981 Kayne
- (73) Assignee: **Enchanted Lighting Company, LLC**, 4,386,392 A 5/1983 Reibling
- Azusa, CA (US) 4,477,249 A 10/1984 Ruzek et al.
- 4,510,556 A * 4/1985 Johnson 362/184
- (*) Notice: Subject to any disclaimer, the term of this 4,519,556 A 5/1985 Timoschuk
- patent is extended or adjusted under 35 4,567,548 A 1/1986 Schneeberger
- U.S.C. 154(b) by 1465 days. 4,593,232 A * 6/1986 McEdwards 315/199
- 4,777,408 A 10/1988 DeLuca
- 4,866,580 A 9/1989 Blackerby
- (21) Appl. No.: **11/179,062** 5,097,180 A 3/1992 Ignon et al.

(22) Filed: **Jul. 11, 2005**

(65) **Prior Publication Data**

US 2006/0119287 A1 Jun. 8, 2006

Related U.S. Application Data

(60) Provisional application No. 60/633,496, filed on Dec. 6, 2004, provisional application No. 60/667,717, filed on Mar. 31, 2005.

(51) **Int. Cl.**
F21V 9/00 (2006.01)

(52) **U.S. Cl.** **362/166**; 362/161; 362/157;
362/810; 362/811

(58) **Field of Classification Search** 362/161,
362/159, 166, 392, 409, 415, 810, 806, 811;
315/185 S, 200 A, 247, 246, 209 R, 224,
315/225, 312-326

See application file for complete search history.

(56) **References Cited**

U.S. PATENT DOCUMENTS

1,736,820 A 11/1929 Black

(Continued)

FOREIGN PATENT DOCUMENTS

CA 1136106 11/1982

(Continued)

Primary Examiner—Tuyet Thi Vo
(74) *Attorney, Agent, or Firm*—Blakely, Sokoloff, Taylor & Zafman LLP

(57) **ABSTRACT**

According to one embodiment of the invention, a method comprises receiving a time-varying power waveform. The power waveform may be periodic and/or phase-controlled. Compressed within a power range associated with the time-varying power waveform, a pulse width modulated (PWM) signal is produced, which is supplied to a light source in order to produce a lighting effect emulating lighting from a candle flame.

25 Claims, 15 Drawing Sheets

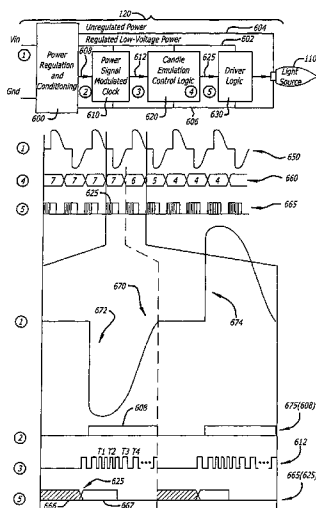

U.S. PATENT DOCUMENTS

5,152,602 A 10/1992 Boschetto
 5,440,456 A 8/1995 Bertling et al.
 5,658,073 A 8/1997 Lee
 5,690,484 A 11/1997 Leonard et al.
 D394,513 S 5/1998 Davis
 5,863,108 A 1/1999 Lederer
 D406,365 S 3/1999 Furner
 5,876,706 A 3/1999 Zaunbrecher
 5,879,151 A 3/1999 Schultz et al.
 5,896,497 A 4/1999 Halstead
 D409,316 S 5/1999 Majerowski
 D410,096 S 5/1999 Majerowski
 5,919,423 A 7/1999 Requejo et al.
 5,924,784 A 7/1999 Chliwnyj et al.
 5,939,005 A 8/1999 Materna
 5,951,153 A 9/1999 Favela
 5,955,034 A 9/1999 Zaunbrecher et al.
 D417,018 S 11/1999 Soller
 5,980,064 A 11/1999 Metroyanis
 6,013,231 A 1/2000 Zaunbrecher et al.
 6,017,139 A 1/2000 Lederer
 6,019,804 A 2/2000 Requejo et al.
 6,036,925 A 3/2000 Adams et al.
 6,053,622 A 4/2000 Horowitz et al.
 D429,828 S 8/2000 Schultz et al.
 6,106,786 A 8/2000 Akahoshi
 6,198,229 B1 3/2001 McCloud et al.
 6,241,362 B1 6/2001 Morrison
 6,309,092 B1 10/2001 Bardeen et al.
 6,361,192 B1 3/2002 Fussell et al.
 6,554,447 B1 4/2003 Kotary et al.
 6,616,308 B2 9/2003 Jensen et al.
 6,685,345 B1 2/2004 Velasquez
 6,719,443 B2 4/2004 Gutstein et al.
 6,769,905 B2 8/2004 Gray et al.
 D502,559 S 3/2005 Delcourt
 6,926,423 B2 8/2005 Bucher
 6,957,906 B2 10/2005 Coushaine et al.
 6,963,180 B2 11/2005 Rose
 7,093,949 B2 8/2006 Hart et al.
 7,093,961 B2 8/2006 Bentley et al.
 7,098,600 B2 8/2006 Li et al.
 D530,838 S 10/2006 Adams
 7,121,686 B1 10/2006 Chu
 7,125,142 B2 10/2006 Wainwright
 7,132,084 B1 11/2006 Roumpos

D533,951 S 12/2006 Adams
 D533,952 S 12/2006 Adams et al.
 D534,282 S 12/2006 Adams et al.
 D534,283 S 12/2006 Adams et al.
 D534,666 S 1/2007 Adams et al.
 D538,450 S 3/2007 Adams et al.
 D541,443 S 4/2007 Adams et al.
 7,201,500 B2 4/2007 Mlshan
 D546,481 S 7/2007 Adams et al.
 7,350,720 B2 4/2008 Jaworski et al.
 7,410,269 B2 8/2008 Harrity et al.
 RE040,934 E 10/2009 Ruud et al.
 2002/0080604 A1 6/2002 Niermann
 2002/0093834 A1 7/2002 Yu et al.
 2003/0035291 A1 2/2003 Jensen et al.
 2005/0169666 A1 8/2005 Porchia et al.
 2005/0169812 A1 8/2005 Helf et al.
 2005/0196716 A1* 9/2005 Haab et al. 431/126

FOREIGN PATENT DOCUMENTS

CA 2262338 8/2000
 CA 2456160 2/2003
 CN 2637894 Y 9/2004
 CN 2778820 Y 5/2006
 CN 2795654 Y 7/2006
 CN 2854329 Y 1/2007
 CN 2854337 Y 1/2007
 CN 2905792 Y 5/2007
 CN 2906311 Y 5/2007
 EP 0137654 4/1985
 EP 0600217 6/1994
 EP 0916892 5/1999
 EP 1419345 5/2004
 FR 2447516 8/1980
 FR 2788101 7/2000
 GB 191224971 12/1913
 GB 498857 1/1939
 GB 499745 1/1939
 GB 588801 6/1947
 GB 700279 11/1953
 GB 2103777 2/1983
 GB 2110810 6/1983
 GB 2357829 7/2001
 JP 11299529 11/1999
 SE 523145 3/2004

* cited by examiner

FIG. 1

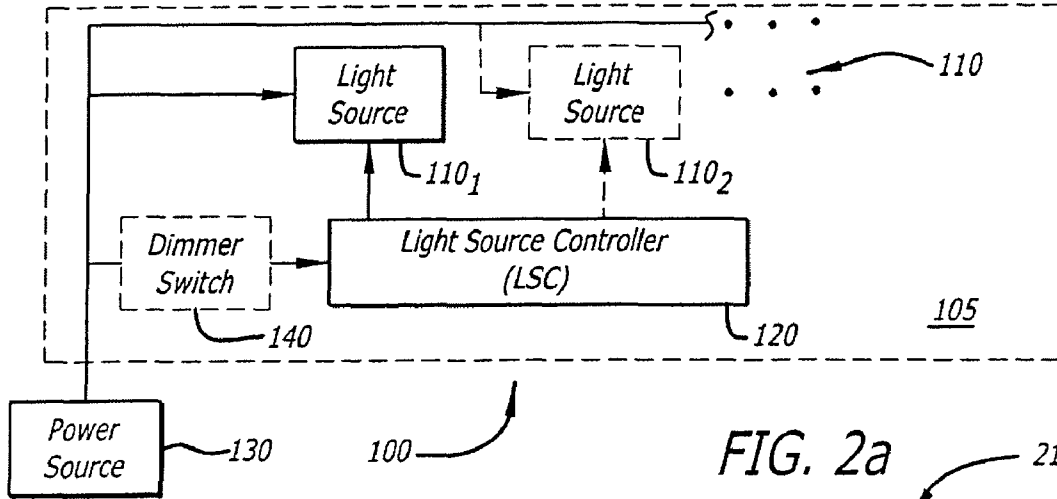

FIG. 2b

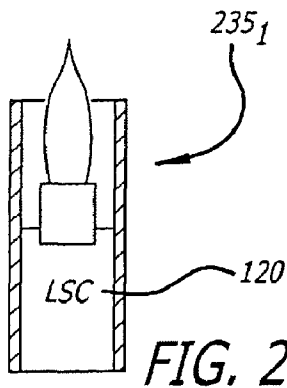
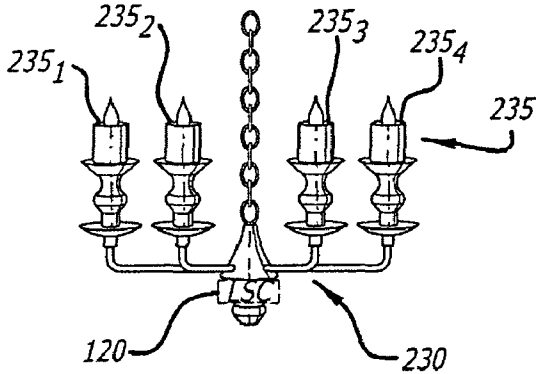

FIG. 2c

FIG. 2a

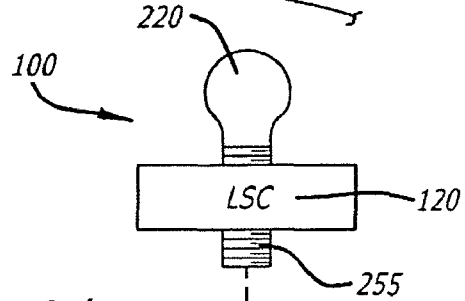
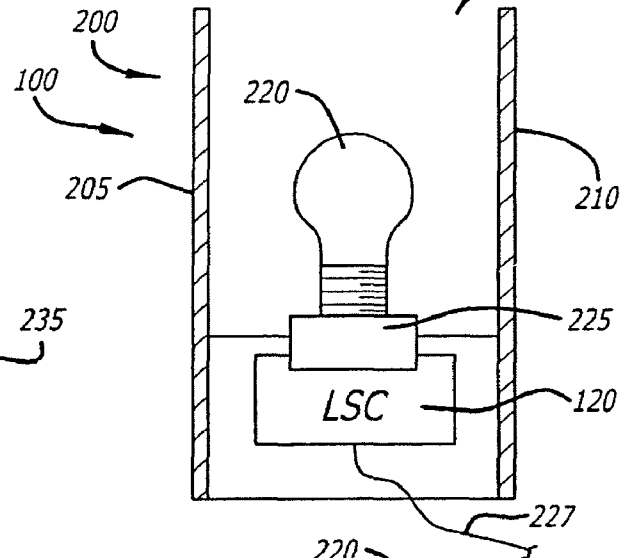
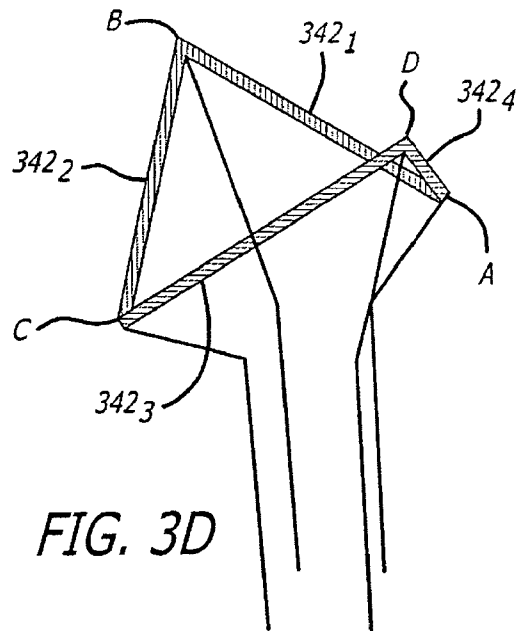
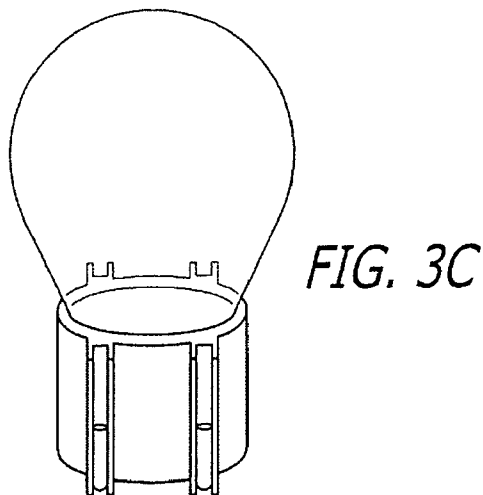
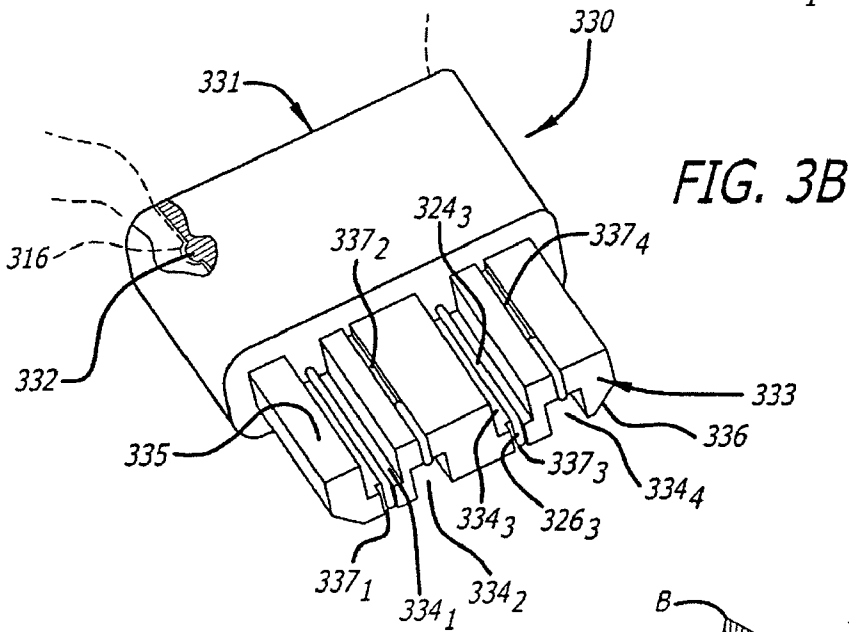
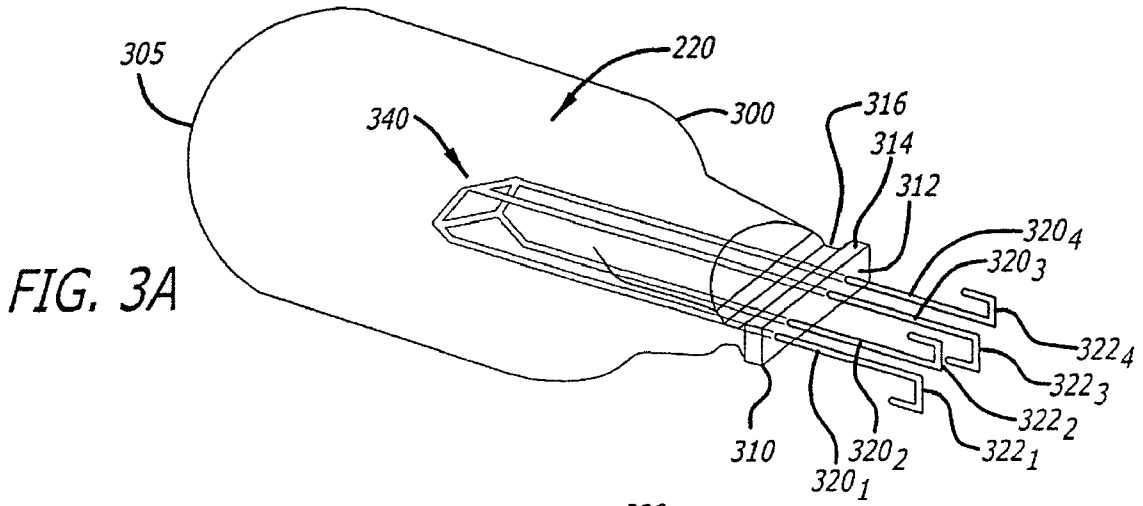

FIG. 2d



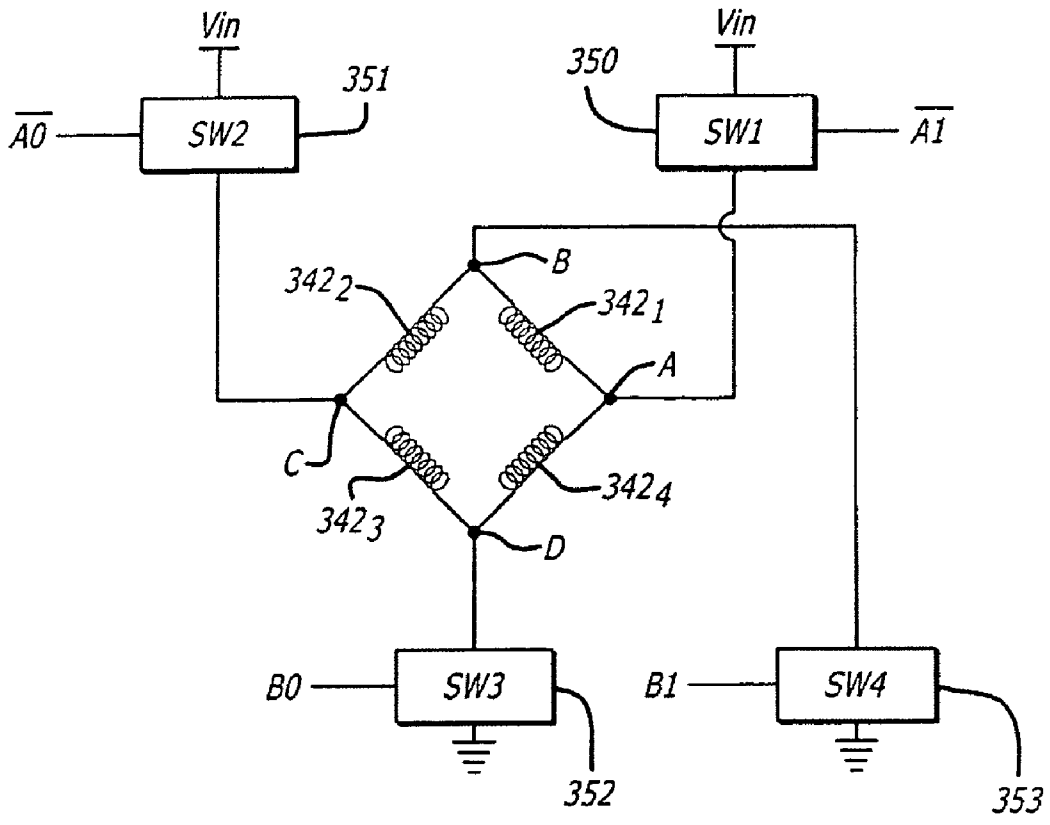

FIG. 3E

	$\overline{A0}$ Low $\overline{A1}$ Hi	$\overline{A0}$ Hi $\overline{A1}$ Low	
$B0$ Low $B1$ Low			
$B0$ Low $B1$ Hi			
$B0$ Hi $B1$ Low			
$B0$ Hi $B1$ Hi			Full Brightness

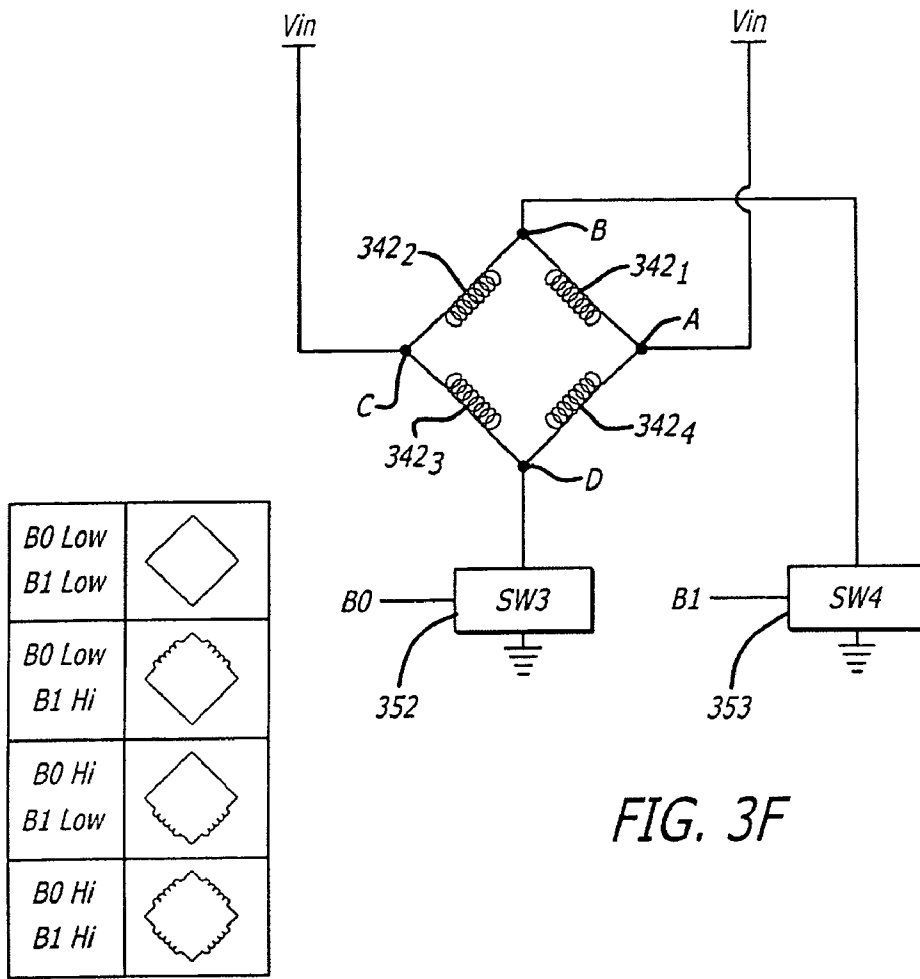

FIG. 3F

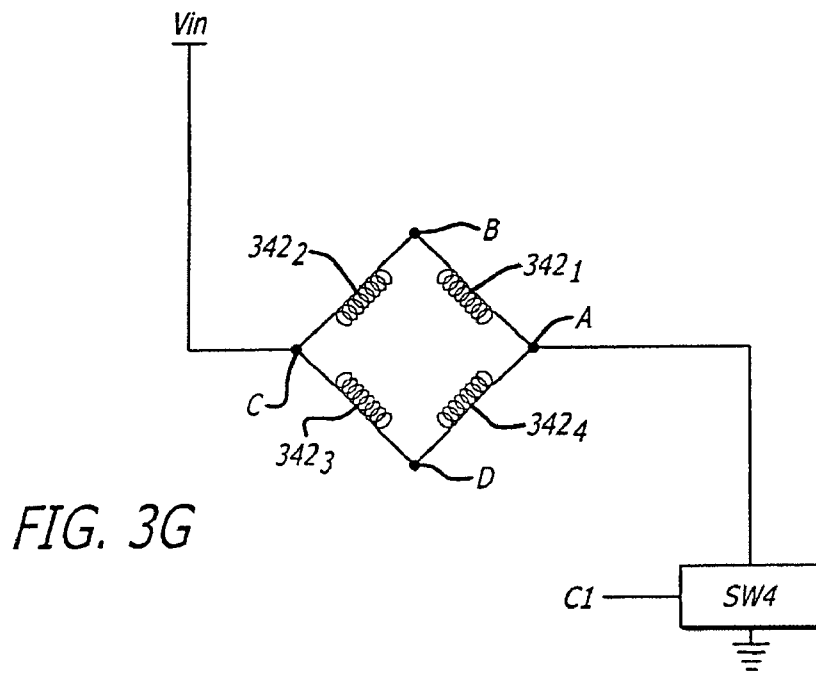

FIG. 3G

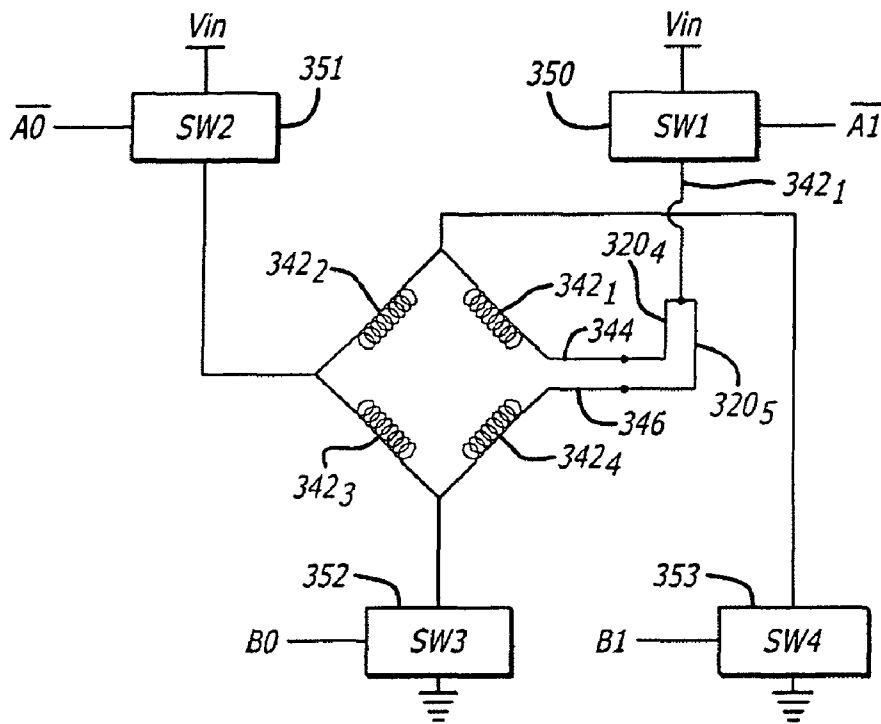

FIG. 3H

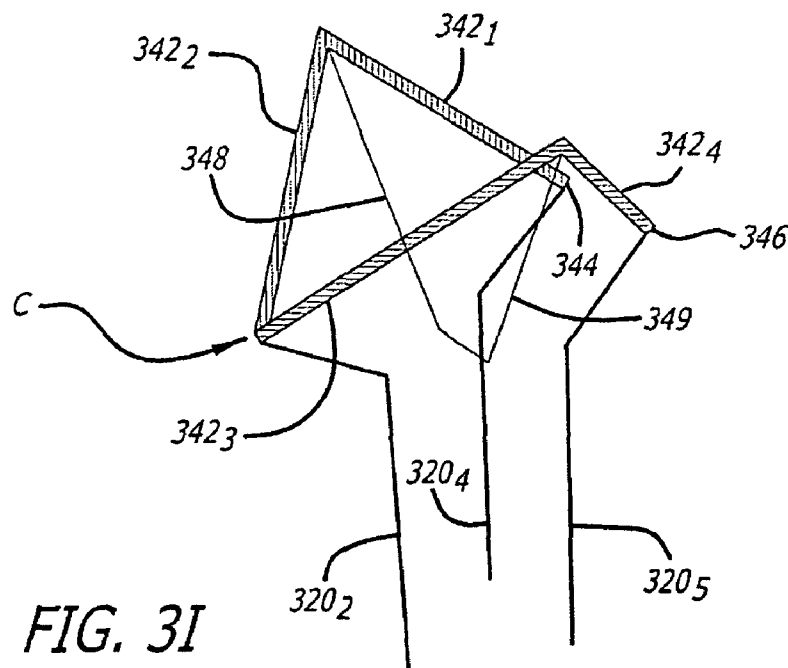

FIG. 3I

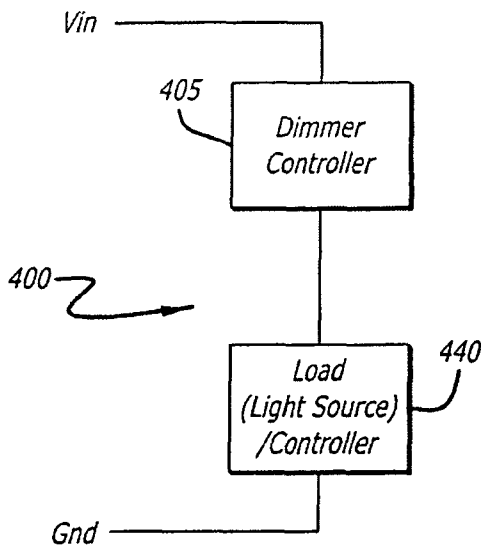

FIG. 4A

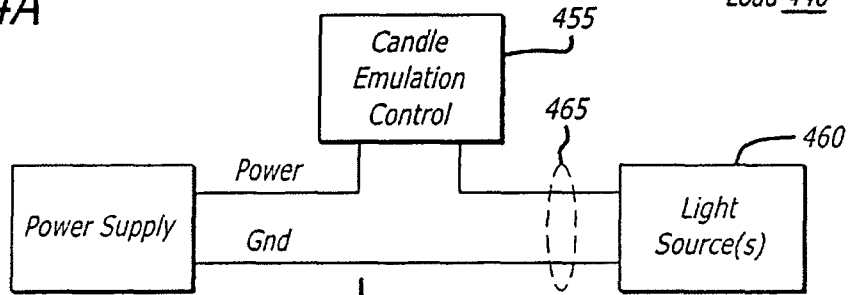
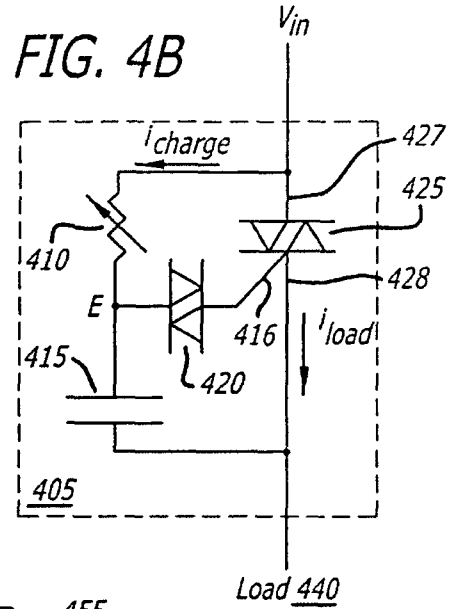
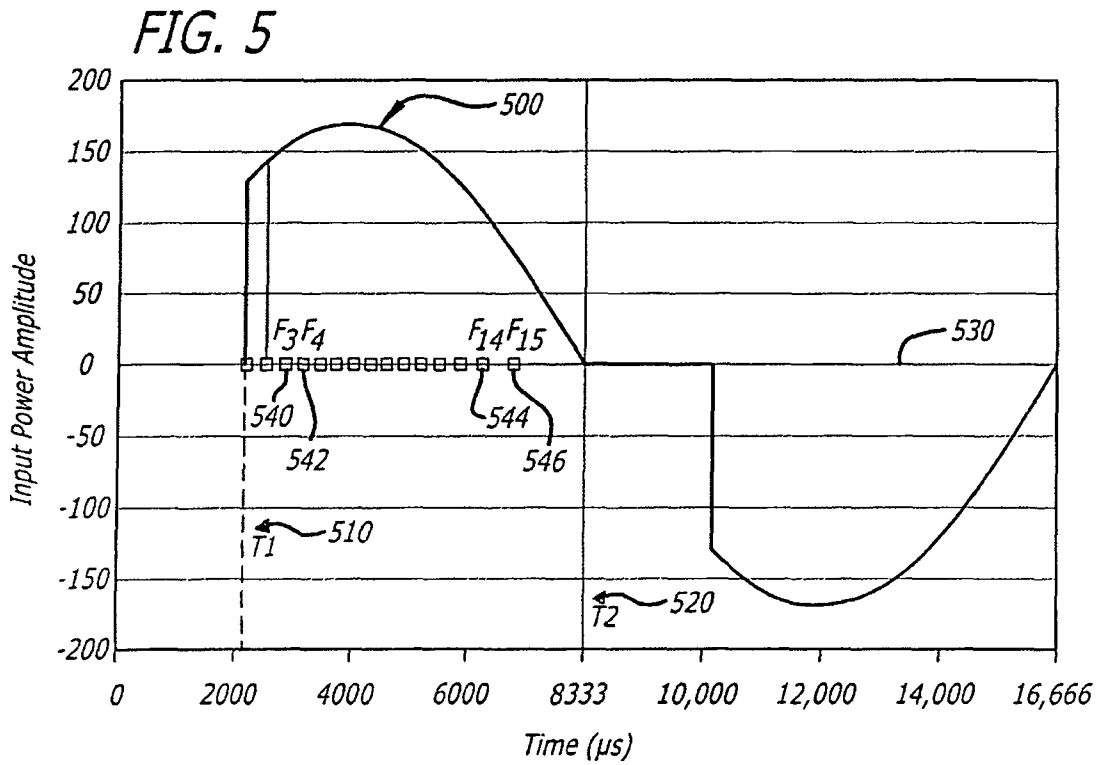
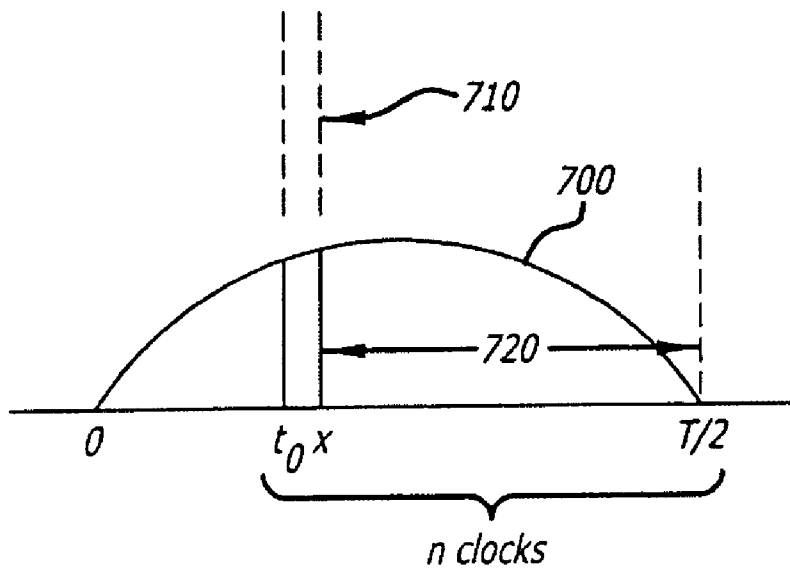

FIG. 4C





$$\int_{t_0}^x \sin(\omega t) dt = \frac{1}{n} \int_{t_0}^{T/2} \sin(\omega t) dt$$

$$\begin{aligned} \Rightarrow \frac{-1}{\omega} \cos(\omega x) + \frac{1}{\omega} \cos(\omega t_0) &= \frac{-1}{n\omega} \cos(\omega T/2) + \frac{1}{n\omega} \cos(\omega t_0) \\ &= \frac{1}{n\omega} \cos(\omega t_0) + \frac{1}{n\omega} \end{aligned}$$

$$\Rightarrow \cos(\omega x) = \left(1 - \frac{1}{n}\right) \cos(\omega t_0) - \frac{1}{n}$$

$$x = \frac{1}{\omega} \arccos\left[\left(\frac{n-1}{n}\right) \cos(\omega t_0) - \frac{1}{n}\right]$$

FIG. 7

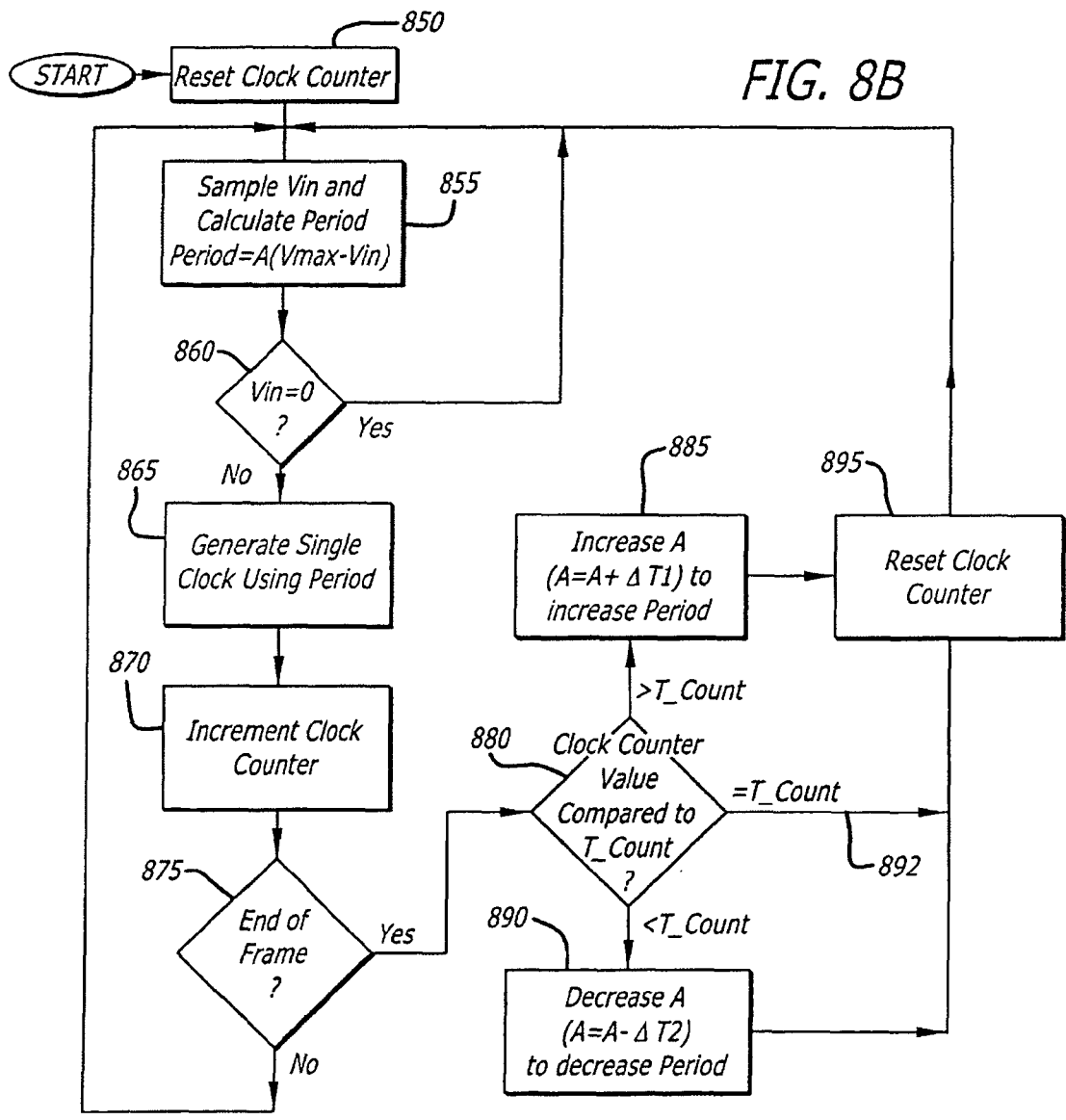
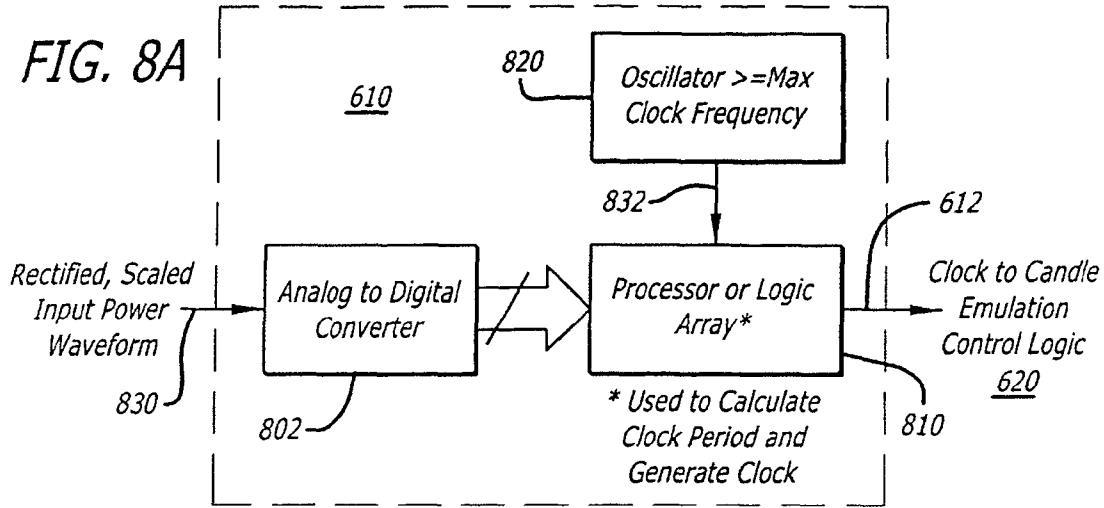

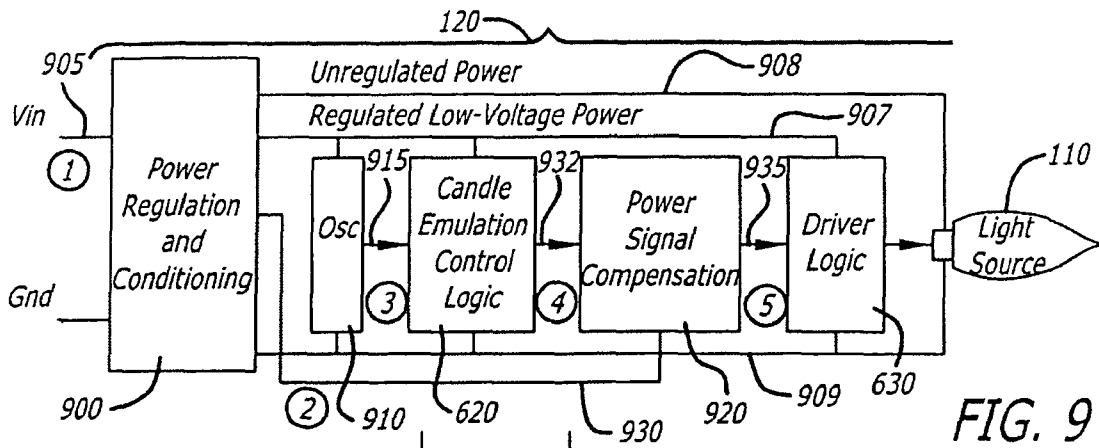

FIG. 9

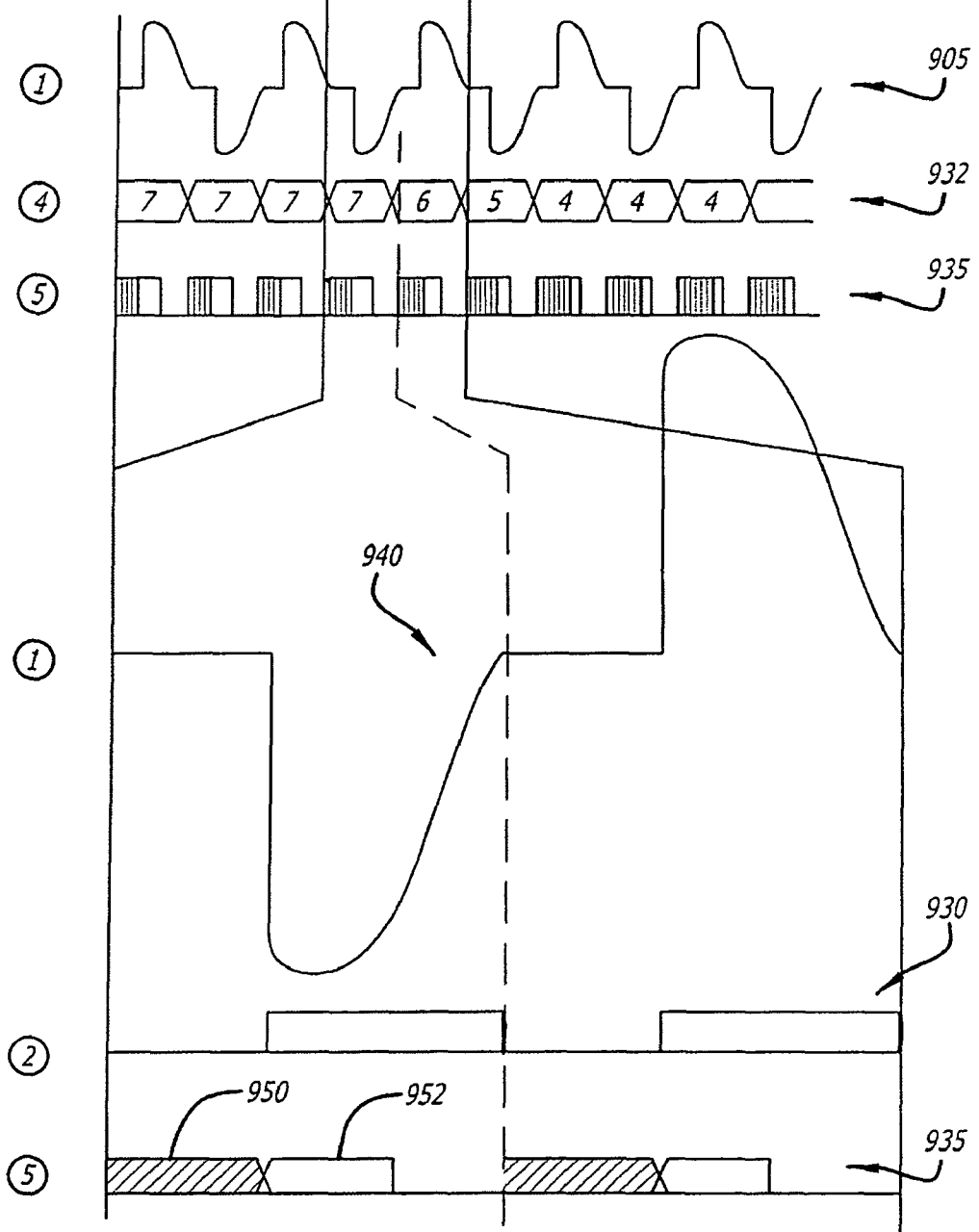

FIG. 10A

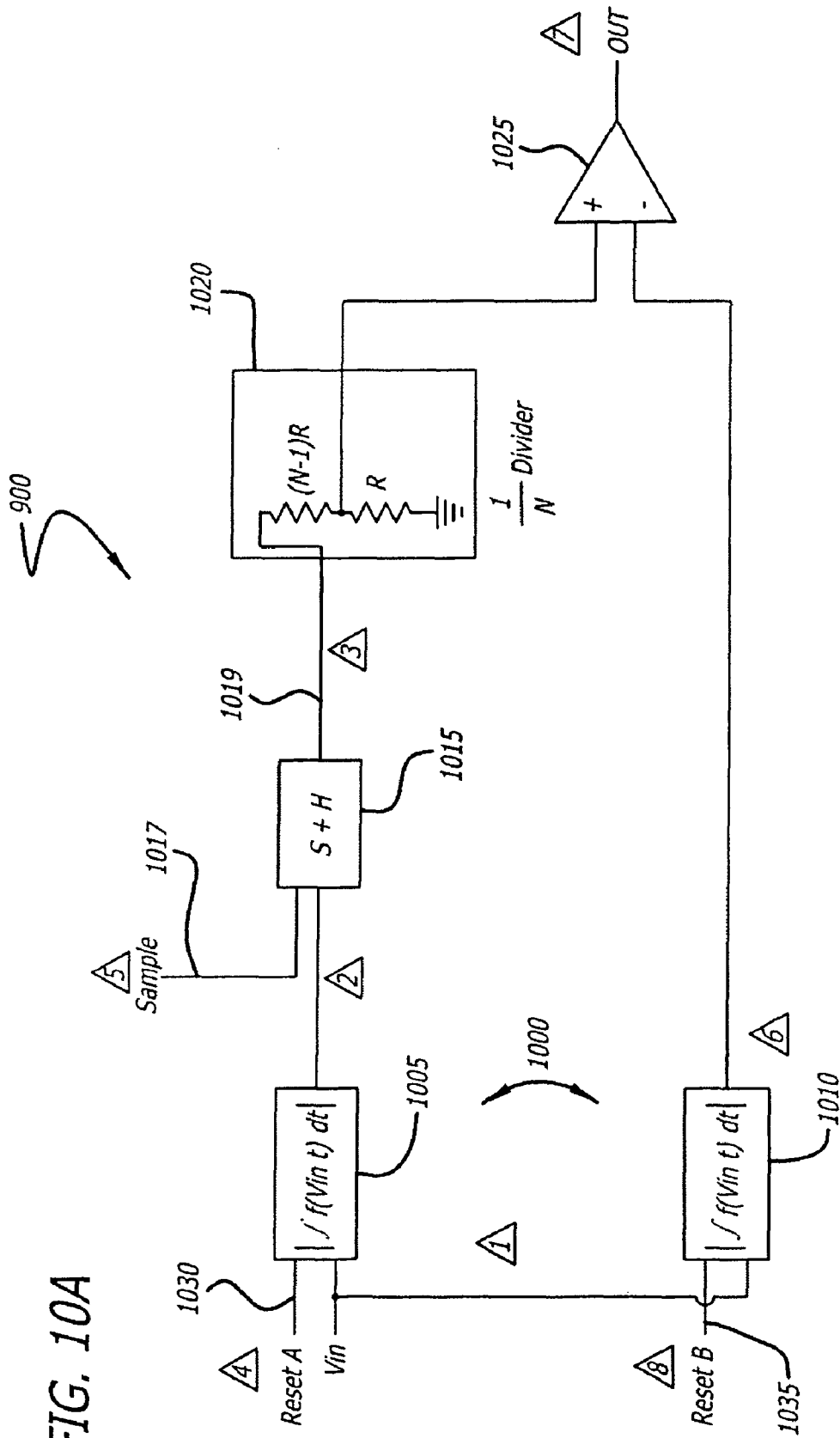
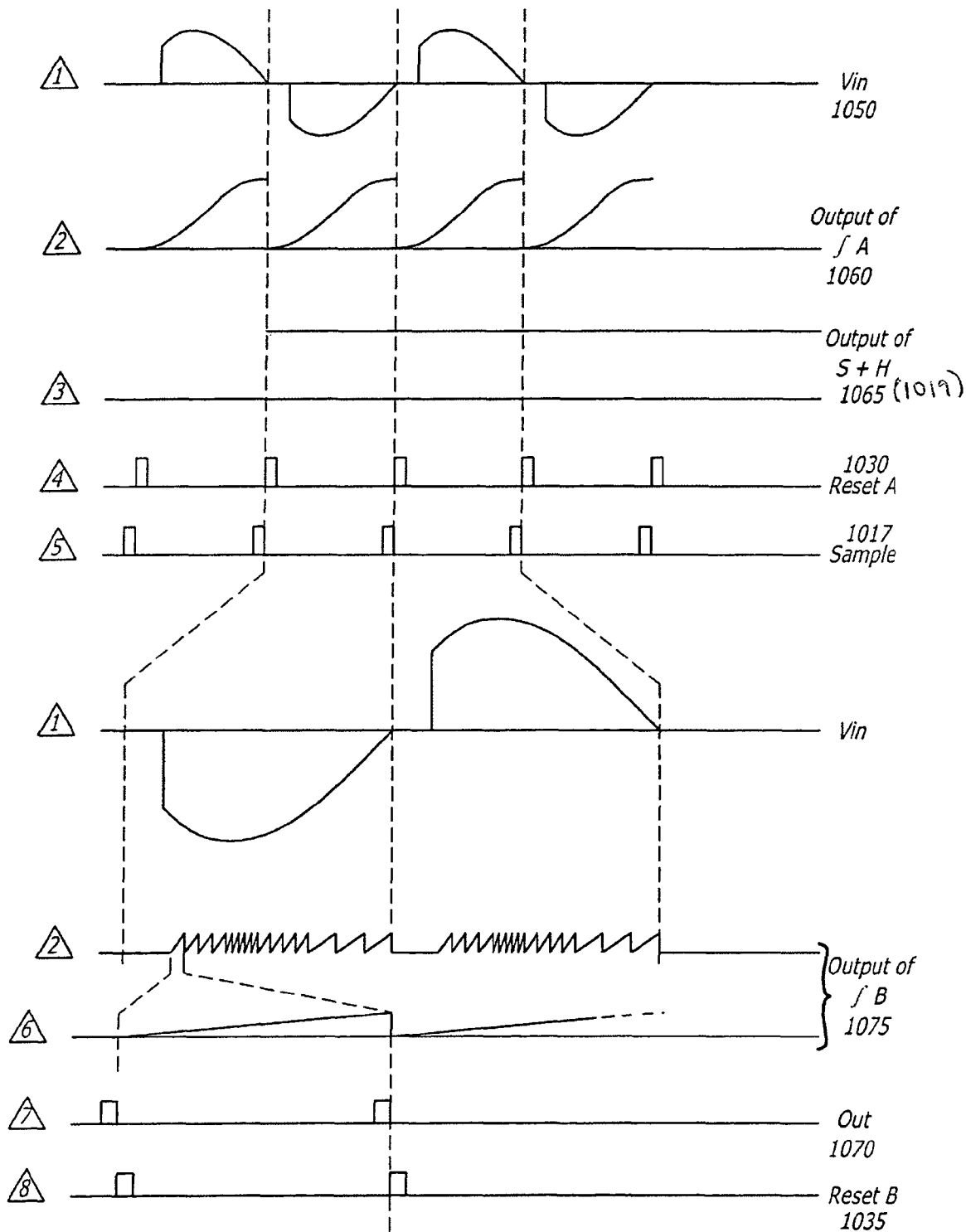

FIG. 10B



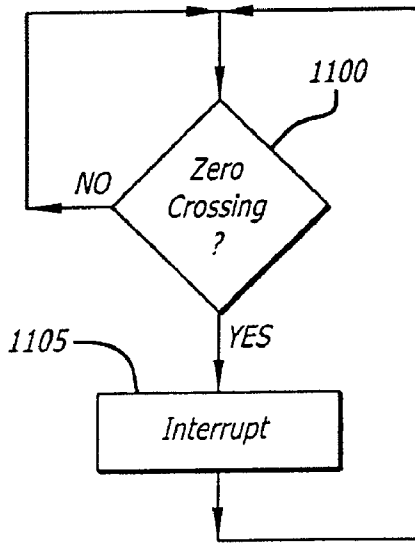

FIG. 11A

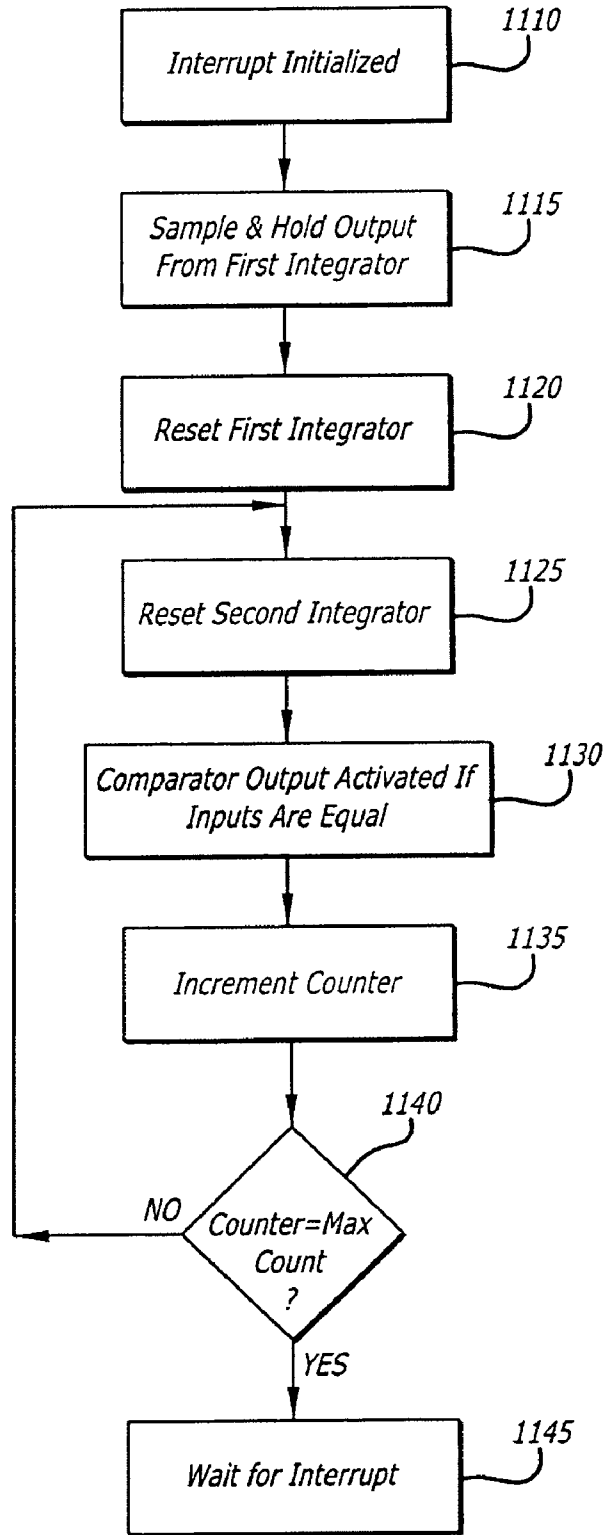

FIG. 11B

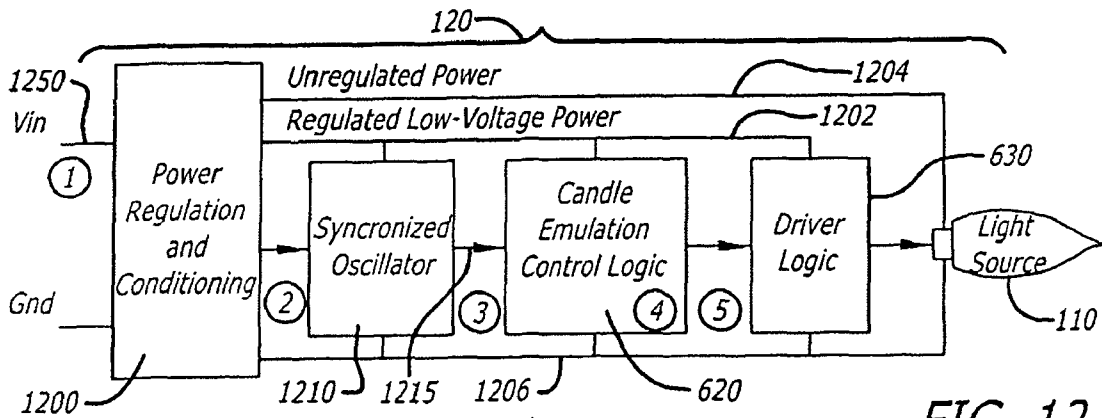
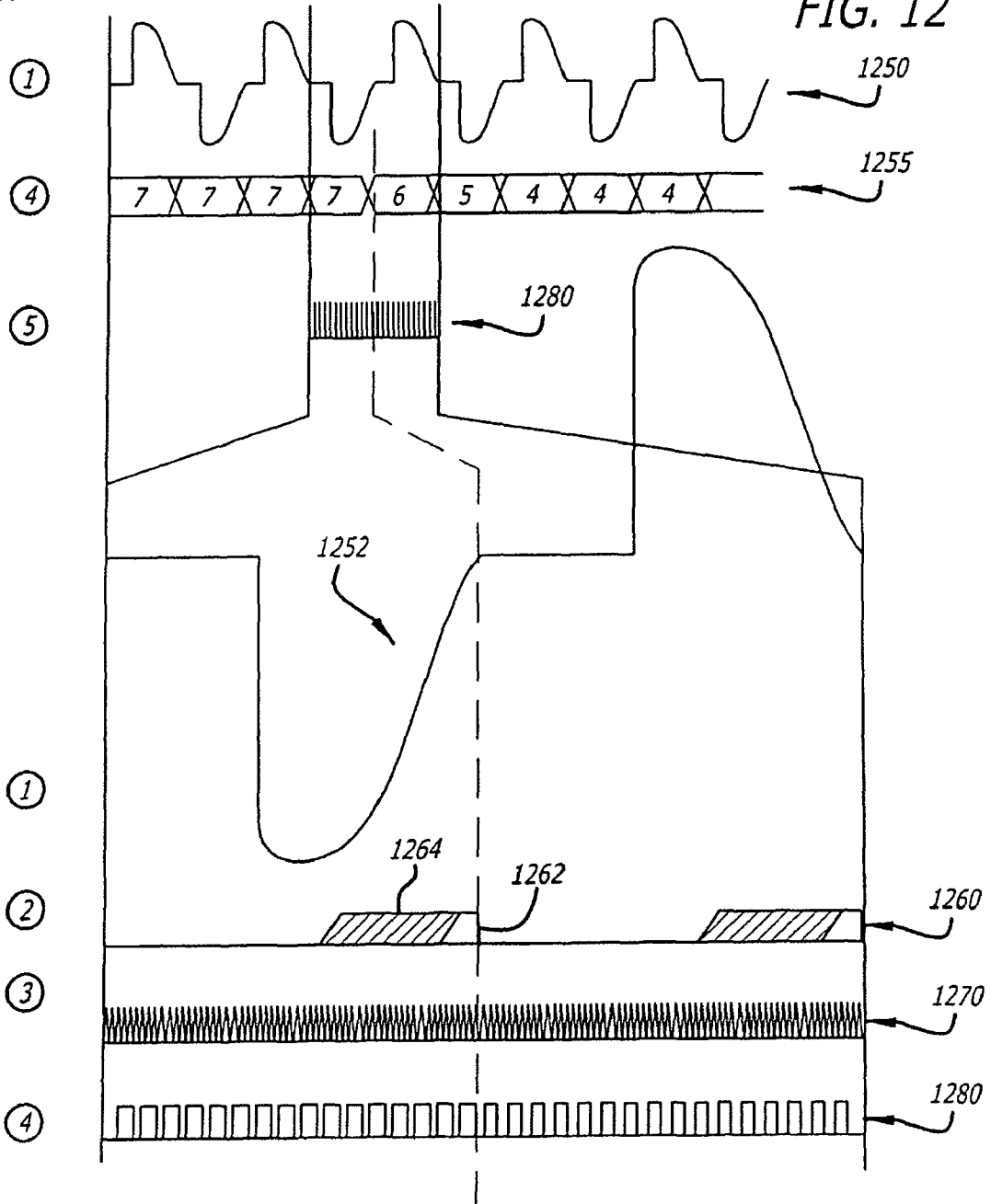
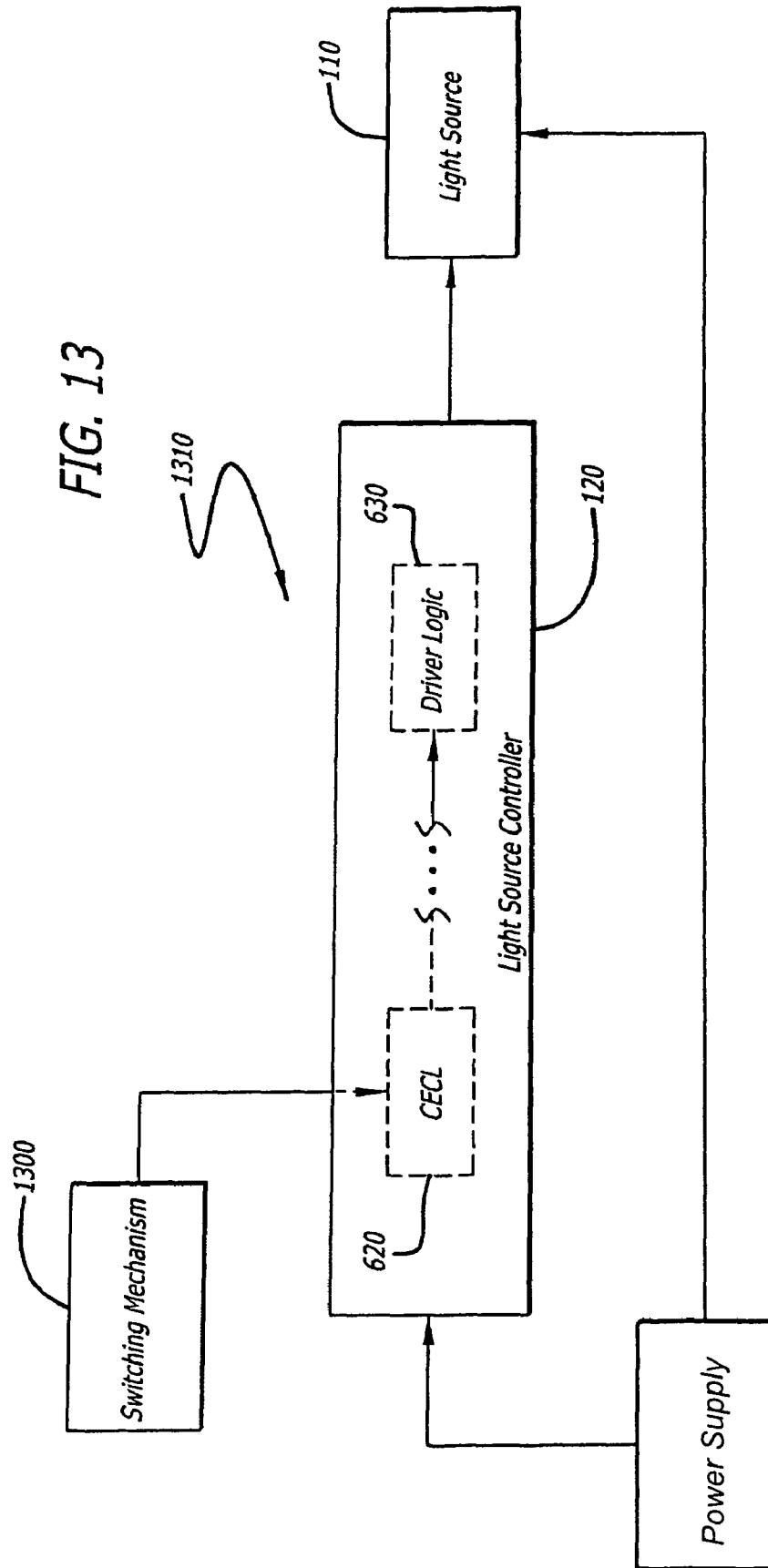

FIG. 12





1

APPARATUS, LOGIC AND METHOD FOR EMULATING THE LIGHTING EFFECT OF A CANDLE

CROSS-REFERENCES TO RELATED APPLICATIONS

This application claims the benefit of priority on U.S. Provisional Application No. 60/633,496 filed Dec. 6, 2004 and U.S. Provisional Application No. 60/667,717 filed Mar. 31, 2005.

FIELD

Embodiments of the invention relate to the field of lighting, in particular, to candle emulation.

GENERAL BACKGROUND

For centuries, wax candles have been used to provide lighting for all types of dwellings. Over the last thirty years, however, wax candles have mainly been used as decorative lighting or as subdued lighting for mood-setting purposes. For instance, restaurants use wax candles as decorations in order to provide a more intimate setting for their patrons. Individuals purchase wax candles for placement around their home to provide a festive or relaxing environment for their guests.

There are a few disadvantages with wax candles. One disadvantage is that they are costly to use when considering operational costs (\$/usage time). In addition to their high cost, wax candles with open flames pose a risk of fire when left unattended for a period of time. These candles also pose a risk of harm to small children who do not understand the dangers of fire.

Accordingly, for cost savings and safety concerns, in certain situations, it would be beneficial to substitute a wax candle for a candle emulation device. Unfortunately, most candle emulation devices do not accurately imitate the lighting effect of a flickering candle, namely a realistic flickering light pattern. For usage by restaurants, this may leave an unfavorable impression by patrons of a restaurant. For usage at home, it may not provide the overall mood-setting effect that the user has tried to create.

BRIEF DESCRIPTION OF THE DRAWINGS

The invention may best be understood by referring to the following description and accompanying drawings that are used to illustrate embodiments of the invention.

FIG. 1 is an exemplary block diagram of a candle emulation device employing the present invention.

FIG. 2A is a first exemplary embodiment of the candle emulation device of FIG. 1.

FIG. 2B is a second exemplary embodiment of the candle emulation device of FIG. 1.

FIG. 2C is a third exemplary embodiment of the candle emulation device of FIG. 1.

FIG. 2D is a fourth exemplary embodiment of the candle emulation device of FIG. 1.

FIG. 3A is a first exemplary embodiment of a light source represented as an incandescent bulb featuring staggered electrical feedthroughs and operating as a light source for the candle emulation device of FIG. 1.

FIG. 3B is an exemplary embodiment of a base of the incandescent bulb of FIG. 3A.

2

FIG. 3C is a second exemplary embodiment of a light source represented as an incandescent bulb.

FIG. 3D is an exemplary embodiment of independently controlled filament construction for the incandescent bulb of FIG. 3A or 3C.

FIG. 3E is a first exemplary schematic diagram of a multi-filament incandescent bulb of FIG. 3A or 3C with each of the four filament segments independently controlled.

FIG. 3F is a second exemplary schematic diagram of a multi-filament incandescent bulb of FIG. 3A or 3C with two of the filament segments independently controlled.

FIG. 3G is a third exemplary schematic diagram of a multi-filament incandescent bulb of FIG. 3A or 3C.

FIG. 3H is a fourth exemplary schematic diagram of a multi-filament incandescent bulb of FIG. 3A or 3C with a each of the four filament segments independently controlled.

FIG. 3I is a fifth exemplary schematic diagram of multi-filament incandescent bulb of FIG. 3A or 3C with a reduced number of electrical lead wires.

FIG. 4A is an exemplary embodiment of a dimmer switch adapted to control the light source in order to emulate a flickering candle.

FIG. 4B is a first exemplary embodiment of the internal components forming the dimmer switch of FIG. 4A.

FIG. 4C is a second exemplary embodiment of the dimmer switch adapted to control the light source in order to emulate a flickering candle.

FIG. 5 is an exemplary embodiment of an input power waveform provided to the dimmer switch of FIGS. 4B or 4C.

FIG. 6 is a first exemplary embodiment of the light source controller operating with the dimmer switch to control the light source in order to emulate a flickering candle and the signaling received and produced by the light source controller.

FIG. 7 is a first exemplary embodiment of the operations performed by the power signal modulated clock of FIG. 6.

FIG. 8A is an exemplary embodiment of the components associated with the power signal modulated clock of FIG. 6.

FIG. 8B is a second exemplary embodiment of the operations performed by the power signal modulated clock as shown in FIGS. 6 and 8A.

FIG. 9 is a second exemplary embodiment of the light source controller operating with the dimmer control to control the light source in order to emulate a flickering candle and the signaling received and produced by the light source controller.

FIG. 10A is an exemplary embodiment of the operations performed by the power regulation and conditioning circuitry of FIG. 9.

FIG. 10B are exemplary embodiments of the signaling received and produced by power regulation and conditioning circuitry in accordance with FIG. 10A.

FIGS. 11A and 11B are exemplary flowcharts of the operations of the power regulation and conditioning circuitry of FIG. 9.

FIG. 12 is a third exemplary embodiment of the light source controller operating with the dimmer control to control the light source in order to emulate a flickering candle and the signaling received and produced by the light source controller.

FIG. 13 is an exemplary block diagram illustrating mode switching controlled by light source controller 120 of FIG. 1.

DETAILED DESCRIPTION

Herein, certain embodiments of the invention relate to an apparatus, logic and method for electrically emulating light-

ing from a candle flame. For instance, one aspect is taking a phase controlled, time-varying (e.g., periodic) power waveform, such as an output of a dimmer switch for example, and applying a fixed or adjusting pulse width modulated frame that is compressed within the available power or voltage in order to control a light source such as an incandescent light bulb for example.

Herein, certain details are set forth below in order to provide a thorough understanding of various embodiments of the invention, albeit the invention may be practiced through many embodiments other than those illustrated. Well-known components and operations are not set forth in detail in order to avoid unnecessarily obscuring this description.

In the following description, certain terminology is used to describe features of the invention. For example, the term “lighting fixture” is generally defined as any device that provides illumination based on electrical input power, where as described below, a “candle emulation device” is merely a lighting fixture providing illumination that emulates the lighting effect of a candle. Examples of various types of lighting fixtures include, but are not limited or restricted to a lamp, a table lamp featuring a pillar or tapered candle housing, a sconce, chandelier, lantern, or the like. Moreover, a “component” or “logic” is generally defined as hardware and/or software, which may be adapted to perform one or more operations on an incoming signal. Examples of types of incoming signals include, but are not limited or restricted to power waveforms, clock, pulses, or other time-varying signals. Also, the term “translucent material” is generally defined as any composition that permits the passage of light. Most types of translucent material diffuse light. However, some types of translucent material may be transparent in nature.

Referring to FIG. 1, an exemplary block diagram of a candle emulation device employing the present invention is illustrated. Candle emulation device **100** comprises one or more light sources $110_1, \dots$, and/or 110_N ($N \geq 1$), generally referred to as “light source **110**,” controlled by a light source controller (LSC) **120** positioned within a housing **105**.

Light source **110** and light source controller **120** are supplied power by a power source **130**, such as line voltage (e.g., ranging between approximately 110-220 volts in accordance with U.S. and International power standards, such as 110 voltage alternating current “VAC” at 50 or 60 Hertz “Hz”, 220 VAC at 50 or 60 Hz, etc.) supplied from a wall socket. Alternatively, power source **130** may be any number of other power supplying mechanisms such as a transformer that supplies low voltage power (12 VAC) for example. As illustrated, power source **130** may be situated external to housing **105** of candle emulation device **100** or, in certain embodiments, may be placed internally therein.

According to one embodiment of the invention, each light source **110** is a single incandescent light bulb that may be electrically coupled to light source controller **120**. Exemplary light sources are illustrated in FIGS. 3A-3I and described below.

Although not shown in FIG. 1, according to one embodiment of the invention, light source controller **120** comprises a circuit board featuring power regulation and conditioning logic, candle emulation control logic and driver logic. The power regulation and conditioning logic is configured to provide regulated, local power from an unregulated input power supplied by power source **130**. The regulated local power is supplied to other components within light source controller **120** such as the candle emulation control logic and the driver logic. The candle emulation control logic is adapted to create a realistic candle lighting pattern. The driver logic is adapted

to mechanically connect with and drive (activate/deactivate) light source **110**. The operation of these components will be described in detail below.

Alternatively, it is contemplated that light source controller **120** may comprise multiple circuit boards with a primary circuit board adapted for power regulation and supplying regulated power to one or more secondary circuit boards responsible for controlling light source **110**. As one example, a secondary circuit board may be adapted to control a single light source 110_1 or multiple light sources 110_1 and 110_2 . As another example, one secondary circuit board may be adapted to control a light source 110_1 while another secondary circuit board may be adapted to control a different light source 110_2 , and the like.

It is contemplated that light source controller **120** may be adapted with a first connector designed so that light source **110** may be removed and replaced with a different light source. Similarly, light source controller **120** may be adapted with a second connector designed so that either light source controller **120** or power source **130** may be removed and replaced as needed.

It is further contemplated that a control unit **140**, optionally shown by dashed lines, may be adapted to cooperate with light source controller **120** to control the illumination of candle emulation device **100** of FIG. 1. For such an embodiment, control unit **140** is a dimmer switch **140** may be situated within housing **105** or external to housing **105**. It is contemplated, however, that control unit **140** may be a light switch, a photocell, a timer or any unit for controlling an illumination output of light source **110**.

Referring now to FIG. 2A, a first exemplary embodiment of candle emulation device **100** of FIG. 1 is shown. Candle emulation device **100** is illustrated as one type of lighting fixture, namely a table lamp including a pillar or tapered candle housing **200** featuring translucent side walls **205** and **210** as well as an uncovered top **215**. Light from an incandescent light bulb **220**, one embodiment of light source **110** of FIG. 1, casts shadows replicating lighting from a candle flame. Translucent side walls **205** and **210** may form part of a polyurethane candle shell having a smooth, textured drippy or otherwise aesthetically pleasing outer surface. Alternatively, translucent sidewalls **205** and **210** may be any other type of translucent material such as a natural or synthetic cloth, paper, plastic, glass, or other suitable material.

A connector **225** is configured as an interface for mating with a complementary base of incandescent light bulb **220**, which provides electrical connectivity between incandescent light bulb **220** and light source controller **120**. A detailed illustration of one embodiment of the base of incandescent light bulb **220** is shown in FIG. 3B, where connector **225** would be configured as a socket.

Normally, the power source would be featured outside of pillar candle housing **200** and power supplied via a power line **227**. However, it is contemplated that power source **130** could be implemented within housing **200** as an alternative embodiment.

Referring to FIG. 2B, a second exemplary embodiment of the candle emulation device of FIG. 1 is shown. Candle emulation device **100** is illustrated as a chandelier that comprises a frame **230** for supporting multiple light sources 235_1 - 235_M ($M \geq 1$), generally referred to as “light sources **235**”. According to one embodiment, light sources **235** may be centrally controlled by light source controller **120** placed within an interior of frame **230** and routing power received from an external power source. However, according to another embodiment illustrated in FIG. 2C, each of the light sources **235** may be controlled in a decentralized fashion, where mul-

multiple light source controllers are placed within the housing of each corresponding light source $235_1, \dots, \text{and } 235_M$ or within frame **230** proximate to each corresponding light source $235_1, \dots, \text{and } 235_M$.

Referring to FIG. 2D, a fourth exemplary embodiment of candle emulation device **100** of FIG. 1 is shown. Configured as part of a single, removable light source **250**, candle emulation device **100** comprises an Edison base **255** for rotational coupling to a lamp, desk light, sconce, or other lighting fixture. Candle emulation device **100** comprises light source controller **120**, which is electrically coupled to both base **255** and incandescent bulb **220** and controls incandescent bulb **220** to provide a lighting effect that emulates a candle flame. It is contemplated that base **255** may be a small, medium or large Edison base, bi-pin base, or any other commonly used light bulb base, which might be adapted for use with candle emulation device **100**.

Referring now to FIG. 3A, an exemplary embodiment of a light source represented as an incandescent light bulb **220** featuring staggered electrical feedthroughs $320_1\text{-}320_R$ ($R \geq 2$) and operating as light source 110_1 for candle emulation device **100** of FIG. 1 is shown. When used with 120 VAC input power, for example, incandescent light bulb **220** might be configured with one or more 60-120 VAC filaments that are designed to operate at approximately 50/50 duty cycle (e.g., during only one-half wave of the AC power cycle) and are controlled to provide a stable, low wattage incandescent light to emulate lighting from a candle flame. Designing the filaments to a lower voltage allows the use of lower wattage filaments that are more mechanically stable and easier to manufacture.

Incandescent light bulb **220** comprises a bulb housing **300** made of glass or high temperature plastic that surrounds one or more filaments **340**. Bulb housing **300** features a closed first end **305** and a second end **310** featuring an opening **312** through which multiple feedthroughs $320_1\text{-}320_R$ extend. Second end **310** of bulb housing **300** features an elongated protrusion **314** formed at a perimeter of opening **312** to create a channel **316**. Channel **316** provides an interlocking mechanism for a base **330** as shown in FIG. 3B.

Each "feedthrough" $320_1\text{-}320_R$ is an electrical lead line extending from second end **310** and coupled to filament **340** within bulb housing **300**. For this embodiment of the invention, four feedthroughs $320_1\text{-}320_4$ are arranged in a staggered orientation with ends 322_1 and 322_3 of first and third feedthroughs 320_1 and 320_3 having a first curvature and ends 322_2 and 322_4 of second and fourth feedthroughs 320_2 and 320_4 having a second curvature. The second curvature may be in a direction consistent with or opposite from the first curvature as shown.

According to one embodiment of the invention, as shown in FIG. 3B, base **330** comprises first end **331** and a second end **333**. First end **331** features a protrusion **332** that, when second end **310** of bulb **300** is inserted into base **330**, interlocks with channel **316**. Of course, it is contemplated that base **330** may be structured in a configuration other than a rectangular form factor, such as a generally circular configuration as shown in FIG. 3C.

Second end **333** of base **330** comprises a first plurality of grooves $334_1\text{-}334_4$ alternatively positioned on a top and bottom surfaces **335** and **336** of base **330**. A corresponding plurality of grooves $337_1\text{-}337_4$, having a lesser width than first plurality of grooves $334_1\text{-}334_4$, are alternatively positioned on bottom and top surfaces **336** and **335** of base **330**. This alternative groove construction exposes multiple sides of ends $322_1\text{-}322_4$ of feedthroughs $320_1\text{-}320_4$ to increase contact area and enable polarizing of base **330**. This increased

contact area provides better connectivity with a corresponding connector for light source controller **120**.

More specifically, as shown, each groove (e.g., groove 334_3) is offset from neighboring grooves 334_2 and 334_4 so that a first segment 324_3 of feedthrough 320_3 is exposed. A second segment 326_3 of feedthrough 320_2 is accessible within groove 337_3 .

FIG. 3D is an exemplary embodiment of independently controlled, multi-filament incandescent light bulb **220** of FIG. 3A or 3C. Herein, four filament segments $342_1\text{-}342_4$ are arranged in an electrically continuous polygon shape and are independently controlled through feedthroughs $320_1\text{-}320_4$, respectively. It is contemplated that fewer or more than four segments may be arranged with a corresponding number of feedthroughs. These feedthroughs $320_1\text{-}320_4$ are attached to intersection points A-D of filament segments $342_1\text{-}342_4$. Filament segments $342_1\text{-}342_4$ may be separate filaments or sections of a single filament.

According to one embodiment of the invention, each filament segment $342_1, \dots, \text{or } 342_4$ is designed to operate at full brightness at 50% duty cycle. For example, filament segment 342_1 may be a 60 VAC filament that is operating at full power and 50/50 duty cycle (e.g., turned on for one-half wave of a 120 VAC power cycle for this embodiment). However, it is contemplated that other duty cycles may be used. For instance, opposite filament segments 342_1 and 342_3 (or 342_2 and 342_4) may be configured with different duty cycles summing to 100% duty cycle (e.g., filament segment 342_1 at 70% duty cycle and filament segment 342_3 at 30% duty cycle; filament segment 342_2 at 80% duty cycle and filament segment 342_4 at 20% duty cycle, etc.) or with collective duty cycles slightly exceeding 100% (e.g., filament segment 342_1 at 60% duty cycle and filament segment 342_3 at 60% duty cycle; filament segment 342_2 at 55% duty cycle and filament segment 342_4 at 60% duty cycle, etc.).

FIG. 3E is a first exemplary schematic diagram of a multi-filament incandescent bulb **220** of FIG. 3A or 3C with each of the four filament segments $342_1, \dots, \text{and } 342_4$ independently controlled. Feedthroughs $320_1\text{-}320_4$ are coupled at points of intersection for various filament segments; namely, intersection point A is between filament segments 342_1 and 342_4 , intersection point B is between filament segments 342_1 and 342_2 , intersection point C is between filament segments 342_2 and 342_3 , and intersection point D is between filament segments 342_3 and 342_4 .

According to this embodiment of the invention, one end of first filament segment 342_1 is coupled to receive input power (V_{in}) when a first switching element **350** (e.g., p-channel transistor) is active (closed). The other end of first filament segment 342_1 is coupled to ground (GND) when a fourth switching element **353** (e.g., n-channel transistor) is active. Hence, first filament segment 342_1 is illuminated when switch input ($\overline{A1}$) is logic low and switch input B1 is logic high.

Similarly, a first end of second filament segment 342_2 is coupled to GND when fourth switching element **353** is active. A second end of second filament segment 342_2 is coupled to V_{in} when a second switching element **351** (e.g., p-channel transistor) is active. This is accomplished when a switch input ($\overline{A0}$) is logic low and switch input B1 is logic high.

As further shown, a first end of third filament segment 342_3 is coupled to V_{in} when second switching element **351** is active (closed). A second end of third filament segment 342_3 is coupled to GND when a third switching element **352** (e.g., n-channel transistor) is active. Hence, third filament segment 342_3 is illuminated when switch input ($\overline{A0}$) is logic low and switch input B0 is logic high.

In addition, a first end of fourth filament segment **342₄** is coupled to GND when third switching element **352** is active. A second end of fourth filament segment **342₄** is coupled to V_{in} when first switching element **350** is active. This is accomplished when a switch input ($\overline{A0}$) is logic low and switch input **B0** is logic high.

Hence, as shown in the operational table of FIG. 3E, each column represents a selected time portion of a power wave cycle that can be used for independent, pulse width modulation control of all filament segments **342₁-342₄**. For instance, as an example, for input power (e.g., 110-220 volt input such as 110 VAC@60 Hz) at 50% duty cycle, filament segments **342₂** and/or **342₃** may operate at 50/50 duty cycle (e.g., powered during a first half of the power cycle) and filament segments **342₁** and/or **342₄** may operate at 50/50 duty cycle (e.g., powered during a second half of the power cycle).

For instance, for this embodiment, during the first half of the power cycle, filament segment **342₂** may be powered a certain percentage of the total cycle time and filament segment **342₃** may be powered a certain percentage, where these percentages do not have to be equal. Similarly, during the second half of the power cycle, filament segment **342₁** may be powered a certain percentage of the total cycle time and filament segment **342₄** may be powered a certain percentage, where these percentages also do not have to be equal. This results in independent, pulse width modulation controlled filament segments. Of course, it is contemplated that filament segments may operate at a different duty cycle instead of the particular 50/50 duty cycle described for illustrative purposes.

As yet another example, presume that input power (e.g., 110-220 VAC input voltage such as 110 VAC@60 Hz) is applied to light source controller **120** where a first set of filament segments (e.g., filament segments **342₂** and/or **342₃**) operate at 70% duty cycle and a first set of filament segments (e.g., filament segments **342₁** and/or **342₄**) operate at 30% duty cycle. During 70% of the power cycle, only filament segments **342₂** and/or **342₃** may be powered. During the remaining 30% of the cycle, filament segments **342₁** and/or **342₄** may be powered, where each filament segment of a set may not be powered equally. This provides different periods of illumination for different filament segments.

FIG. 3F is a second exemplary schematic diagram of a multi-filament incandescent bulb of FIG. 3A or 3C with two of the filament segments independently controlled. In contrast with the configuration of FIG. 3E, intersection point A between filament segments **342₁** and **342₄** and intersection point C between filament segments **342₂** and **342₃** are continuously coupled to input power (V_{in}).

As shown, filament segments **342₁** and **342₂** are coupled in parallel and filament segments **342₃** and **342₄** are coupled in parallel. By activating SW3, SW4, or both, as shown in the operational table of FIG. 3F, each for some percentage of time, independent, pulse width modulation control of groups of filament segments is achieved, namely filament segments **342₁-342₂** and **342₃-342₄** respectively.

FIG. 3G is a third exemplary schematic diagram of a multi-filament incandescent bulb of FIG. 3A or 3C. As shown, filament segments **342₁** and **342₂** are in series and collectively in parallel with filament segments **342₃** and **342₄** which are also in series. This produces a light bulb that emulates lighting from a candle flame through PWM of power signals applied to filament segments **342₁-342₄**, but may not have a shifting flame effect as set forth in FIGS. 3E and 3F.

In summary, the purpose of this multi-filament bulb structure is to provide a uniform replacement bulb for all types of fixtures. The electronics in the light source controller, namely

the existence and control of the switching elements within driver circuitry of the light source controller, dictates the operability of the incandescent light bulb.

FIG. 3H is a fourth exemplary schematic diagram of a multi-filament incandescent bulb of FIG. 3A or 3C with each of the four filament segments independently controlled as described in FIG. 3E. Herein, four filament segments **342₁-342₄** are arranged in an electrically discontinuous polygon shape with no direct coupling of filament segments **342₁** and **342₄**. Instead, separate ends **344** and **346** of filament segments **342₁** and **342₄** are coupled to feedthroughs **320₄** and **320₅**, respectively. These feedthroughs **320₄** and **320₅** may be electrically coupled together outside bulb housing **300** of FIG. 3A or 3C, so that only four feedthroughs **320₁-320₄** are adapted to base **330**.

FIG. 3I is a fifth exemplary schematic diagram of multi-filament incandescent bulb of FIG. 3A or 3C with a reduced number of electrical feedthroughs **320₂**, **320₄** and **320₅**. As shown, electrical feedthroughs **320₂** would be attached at intersection point C between filament segments **342₂** and **342₃**. Electrical feedthroughs **320₄** would be coupled to end **344** of filament segment **342₁** while electrical feedthrough **320₅** would be coupled to end **346** of filament segment **342₄**. Non-conductive supports **348** and **349** are arranged to support filament segments **342₁-342₄**, where supports **348** and **349** differ from feedthroughs because they remain isolated within bulb housing **300** of FIG. 3A or 3C. These supports **348** and **349** may be made of electrically non-conductive material.

Referring now to FIG. 4A, an exemplary embodiment of a dimmer switch **400** featuring a dimmer controller **405** adapted to control a load **440**, such as light source controller **120** and corresponding light source **110** of FIG. 1 for example, in order to emulate lighting from a candle flame. Dimmer controller **405** may have any number of topologies such as a delayed-fired triac architecture as shown in FIG. 4B, or architectures without a triac element such as a variac based wall dimmer and the like.

FIG. 4B is a first exemplary embodiment of the internal components forming dimmer controller **405** of FIG. 4A. According to this embodiment, dimmer controller **405** comprises a variable resistor **410**, a capacitor **415**, a diac component **420** and a triac component **425**. As shown, variable resistor **410** is coupled to capacitor **415** at node E, creating a RC circuit. A first terminal **421** of diac component **420** is coupled to the RC circuit at node E while a second terminal **422** of diac component is coupled to a gate terminal **426** of triac component **425**. The remaining terminals **427** and **428** of triac component **425** are coupled to input power (V_{in}) and load **440** over a main power line, thereby allowing current (i_{load}) to flow to load **440** when gate terminal **426** is activated.

At start-up, triac component **425** is turned off so i_{load} is not flowing to load **440**. Instead, a charging current (i_{charge}) flows through variable resistor **410** and charges capacitor **415**. Once node E reaches a triggering voltage for diac component **420**, diac component **420** goes low resistance and conducts, applying a pulse to gate terminal **426**. As a result, triac component **425** is turned on to allow i_{load} flows to load **440**.

Triac component **425** remains turned on until i_{load} falls below a minimum current threshold. For one embodiment of the invention, where V_{in} is a phase controlled, time-varying power waveform such as AC power signal for example, at every zero crossing of the AC power signal, triac component **425** is turned off because i_{load} would diminish below a current threshold upon reaching the zero crossing and would not be turned on until later in the AC half-cycle.

FIG. 4C is a second exemplary embodiment of a dimmer switch **450** adapted with a candle emulation controller **455**

coupled in series with one or more light sources **110** and controlling the light sources in order to emulate lighting produced from a candle flame. According to this embodiment, candle emulation controller **455** is logic combining the functionality of light source controller **120** with a dimmer controller.

For this example, candle emulation controller **455** is coupled in series between power supply **130** and light source **460** through pre-existing power lines **465**. Candle emulation controller **455** could be placed into a single housing (not shown) that can be placed into an electrical box previously used by a conventional light switch. This embodiment differs from dimmer switch **400** of FIG. 4A due to the physical separation of the light source controller and light source **460**. Herein, light source **460** could be a sconce, porch light or other light that is now controlled to emulate lighting from a candle flame using existing wiring from the electrical box and remotely placed from the light source controller.

Referring to FIG. 5, an exemplary embodiment of a phase controlled, periodic power waveform (also generally referred to as an "input power waveform") **500** supplied from dimmer switch **400** of FIG. 4A is shown. More specifically, for this embodiment, input power waveform **500** is based on a phase controlled, time-varying power waveform such as AC power signal (e.g., e.g., 110-220 volt input such as 110 VAC at 60 Hz). When the user raises or lowers the amount of dimming, the turn-on point of the power shifts back and forth, cutting off some amount of each half-wave of power. In theory, as shown, the voltage amplitude of input power waveform **500** supplied from the delayed-fired triac component is zero is when the RC circuit is charging. In practice, however, there may be a high impedance path through triac component **425** shown in FIG. 4B that would allow the input voltage to drift up toward V_{in} if not pulled down with a resistor or other load. As long as the triac component is turned off, however, only a very small and specified amount of leakage current would flow through the triac component.

At T1 **510** (e.g., approximately 2000 microseconds " μ s"), the RC circuit has been charged to cause the diac component to turn on the triac component. The voltage amplitude of input power waveform **500** now matches V_{in} . Thereafter, it continues to follow AC power signaling until T2 **520** (e.g., 8333 μ s), where the triac component would be turned off and the RC circuit would begin to recharge.

The data points (F_i , where $1 \leq i \leq 15$) computed along a time axis **530** illustrate equal area under input power signal **500**, which represents equal slices of voltage that can be applied to a light source. For instance, the time difference between data points F_3 **540** and F_4 **542** is substantially less than the time difference between data points F_{14} **544** and F_{15} **546**. The reason is that higher voltages are applied at F_3 **540** and F_4 **542** than F_{14} **544** and F_{15} **546**. Thus, applying one fifteenth ($1/15$) of the total voltage to the load would require the light source to be turned on for the duration from F_3 **540** to F_4 **542** or from F_{14} **544** and F_{15} **546** for example.

Referring now to FIG. 6, a first exemplary embodiment of light source controller **120** operating with a dimmer controller to control a light source in order to emulate lighting from a candle flame and signaling received and produced for a single filament is shown. As shown, for this embodiment, a single light source **110** is controlled by light source controller **120** that comprises power regulation and conditioning logic **600**, a power signal modulated clock **610**, candle emulation control logic **620** and driver logic **630**. It is contemplated, however, that multiple sets of drivers and multiple sets of light

sources may be controlled by candle emulation control logic **620**, or alternatively, controlled by multiple candle emulation control logic units.

As shown, power regulation and conditioning logic **600** receives input power (V_{in}) **650** and ground (GND). V_{in} **650** may be DC power or AC power at any selected duty cycle such as seventy-five percent (75%) as shown. Power regulation and conditioning logic **600** produces both a regulated low voltage power **602** (e.g., 5V, 12V, etc.) and an unregulated voltage power **604**, and supplies GND signaling through ground lines **606**. Regulated low voltage power **602** is supplied to components of light source controller **120**, namely power signal modulated clock **610**, candle emulation control logic **620** and driver logic **630**. Unregulated voltage power **604** is supplied to light source **110** in order to avoid supplying a substantial amount of regulated voltage to power a high wattage light source such as a 60 W or 100 W incandescent light bulb. Unregulated power **604** may be filtered and/or even a rectified version of V_{in} **650**.

Power signal modulated clock **610** receives a control signal **608** from power regulation and conditioning logic **600** that provides information on the timing of the turn-on and turn-off points of triac component **425** for dimmer switch **400** of FIG. 4B. In other words, power signal modulated clock **610** produces a clock **612** that is applied to candle emulation control logic **620** based on information pertaining to V_{in} **650**, the input power waveform.

Candle emulation control logic **620** receives clock **612** and outputs pulse width modulated (PWM) signals **625** to driver logic **630**. These PWM signals **625** activate and deactivate components of driver logic **630** in order to control light source **110** to emulate lighting from a candle flame. For this embodiment of the invention, candle emulation control logic **620** is outputting values at 50/50 duty cycle such as every half power cycle at 120 HZ if V_{in} is 60 HZ AC power for example. Examples of candle emulation control logic **620** include, but are not limited to an application specific integrated circuit (ASIC), a programmable processor or controller (e.g., micro-controller), a field programmable gate array, combinatorial logic or the like.

For this embodiment, driver logic **630** is configured with switching hardware such as metal-oxide semiconductor field-effect transistors (MOSFETs), triac components, bipolar junction transistors, or the like. Regardless of the circuitry deployed, the switching hardware is configured to activate and deactivate the load (e.g., various filaments) of the light source.

As further shown in FIG. 6, exemplary embodiments of the signaling received and produced by light source controller **120** are shown. As illustrated, a first waveform **650** illustrates the phase controlled, time-varying, input power waveform (V_{in}) that, for this embodiment, is a resultant periodic AC (60 Hz) power signal produced by a delay-fire triac component **425** of FIG. 4B of dimmer switch **400**. Although not shown, input power waveform (V_{in}) may be a modulated power waveform with a high frequency carrier with appropriate amplitude modulation with polarity switching as produced by electronic transformers. As an example, the carrier would be a high frequency signal and the baseband signal would be first waveform **650**.

As further shown, a second waveform **660** illustrates the values being produced internally by candle emulation control logic **620**. More specifically, candle emulation control logic **620** receives clock **612** from power signal modulated clock **610** and produces values, which differ or are equal in width every power half-cycle of the input power waveform (e.g., at 120 Hz). These values are used to identify a particular amount

of voltage applied to the load. For instance, where a power half-cycle constitutes fifteen (15) time slices, the value “7” indicates that $\frac{7}{15}$ of the voltage available is applied to the load.

A third waveform **665** is the actual value being multiple PWM signals **625** output to driver logic **630** of FIG. 6. Herein, waveform **665** is active-high, and thus, components of driver logic **630** are activated when waveform **665** is logic high and are deactivated when waveform **665** is logic low.

As still shown in FIG. 6, a detailed perspective of a power cycle of input power waveform (V_{in}) and certain resultant signals produced by components of light source controller **120** are shown. For instance, waveform **670** is a detailed illustration of a single power cycle of first waveform **650** having a first power half-cycle **672** and a second power half-cycle **674**.

A waveform **675** is representative of control signal **608** from power regulation and conditioning logic **600** that provides information on the timing of the turn-on and turn-off points of the dimmer switch’s triac component. It is contemplated that waveform **675** may have an analog format. Waveform **675** merely provides information to power signal modulated clock **610** regarding V_{in} such as when is power being turned on and turned off, how much power is available at a certain time, and the like.

A portion of clock **612** generated by power signal modulated clock **610** is further shown. The purpose of clock **612** is to clock candle emulation control logic **620** in such a way that the varying input voltage is being adjusted for terms of the time that the output is activated.

Herein, the periodicity of clock **612** is varied based on the input power waveform **670**. More specifically, clock **612** is frequency modulated by input power waveform **670** such that clock **612** experiences a higher frequency when input power waveform **670** has a higher amplitude, and experiences a lower frequency when input power waveform **670** has lower amplitude. In other words, clock **612** is more compressed the higher the voltage amplitude of input power waveform **670**.

For this illustrative embodiment, the clock pulse widths at time T1 and T2 are substantially narrower than the clock pulse widths at times T3 and T4. In other words, the periods of the clock cycles vary. It is noted that, for one embodiment of power signal modulated clock **610**, a predetermined number of clock pulses (e.g., approximately 240 clock pulses) are provided for each power half-cycle **672** or **674**. For each power half-cycle, candle emulation control logic **620** outputs a series of PWM output signals (referred to as “PWM frame”), and thus, by altering the clock pulses, the PWM output signals may be adjusted accordingly.

A more detailed illustration of a portion of third waveform **665** is shown. This portion illustrates the actual output to driver logic **630** where, in a first region **666** of waveform **665**, the triac component **425** in the dimmer switch is not activated. However, driver logic **630** continues to receive power and continue to charge the RC circuit in the dimmer switch. As soon triac component **425** is set as shown in region **667**, candle emulation control logic **620** waits for a programmed time period (e.g., $\frac{7}{15}$ of power half-cycle) until light source **110** is to be turned off. At that time, power is turned off and an appropriate amount of time is waited until the power is turned on (e.g., around zero-crossing of input power waveform **670**) so that the RC circuit is allowed to operate correctly.

FIG. 7 is a first exemplary embodiment of the operations performed by power signal modulated clock **610** of FIG. 6. This embodiment involves computing time-varying clock periods at approximately 50/50 duty cycle, such as over each half-cycle of input power waveform **700** ($\text{Sin}(\omega t)$) as illus-

trated therein. Of course, estimation and use of tables rather than iterative computations may simplify the computations.

At start time (t_0), a time when the dimmer switch turns on or certain number of clocks after, “n” clocks need to be provided before the end of the power half-cycle ($T/2$). The period **710** of the next clock pulse is set to be equal to the difference of “x” (to be computed) and t_0 .

Therefore, an integral is taken from time t_0 to time “x” of input power waveform ($\text{Sin}(\omega t)$) **700** and it is set equal to one-nth of the full amount of remaining power **720** that is remaining, being the power of the half-cycle from time t_0 to time “ $T/2$ ”. Hereafter, time “x” is computed and this iterative process is used to compute the period of the next clock pulse. Of course, tables may be used to provide estimated values in order to reduce the computational intensity required by power signal modulated clock **610** of FIG. 6.

FIG. 8A is an exemplary embodiment of components implemented within power signal modulated clock **610** of FIG. 6. Power signal modulated clock **610** comprises an analog-to-digital (A/D) converter **800**, processing logic **810** and an optional oscillator **820**. Herein, A/D converter **800** receives a rectified, scaled input power waveform **830** and measures the amount of voltage associated therewith. Based on the measured voltage levels of power waveform **830**, processing logic **810** computes clock **612**, which is a frequency modulated clock signal formed as a collective of clock pulses varying in time so that each clock period is associated with a substantial equal amount of measured voltage of input power waveform **830**. As an optional feature, oscillator **820** is adapted to provide a base clock **832** to processing logic **810**, where base clock **832** would oscillate at a frequency greater than the maximum clock frequency of clock **612**. It is contemplated, of course, that processing logic **810** may be asynchronous logic, thereby not requiring any external clocking signals from oscillator **820**.

Referring now to FIG. 8B, a second exemplary embodiment of the operations performed by power signal modulated clock **610** of FIGS. 6 and 8A is shown. For this embodiment, “ V_{in} ” is considered to be an input AC power waveform that is used to produce a frequency modulated clock signal.

Initially, a clock counter is reset and V_{in} is sampled to calculate a new period (PERIOD) according to Equation 1 (see blocks **850** and **855**):

Equation 1:

$$\text{PERIOD} = A(V_{max} - V_{in}), \text{ where}$$

“A” is a predetermined amplitude;

“ V_{max} ” is a maximum voltage for the input power waveform; and

“ V_{in} ” is the sampled voltage of the input power waveform.

For this illustrative embodiment, as shown in block **860**, a determination is made whether V_{in} is a non-zero value (or alternatively reaches a predetermined minimum threshold voltage where $V_{in} \geq |V_{min}|$). If so, a single clock is generated using the predetermined clock period and the clock counter is incremented (blocks **865** and **870**). Otherwise, a wait state occurs and V_{in} is measured again.

Next, a determination is made whether V_{in} has fallen below a minimum voltage threshold ($V_{in} < |V_{min}|$) “ V_{min} ” may be a programmable value or a preset, static value. As an example, where V_{in} is a 110 volts (@60 Hz) power waveform, V_{min} may be set at five (5) volts for example. As another example, V_{in} is any power waveform based on any voltage, most likely ranging between 110-220 volts in accordance with U.S. and International standards. The purpose of this determination is to detect an end of PWM frame (block **875**).

In the event that an end of the PWM frame has not been detected, V_{in} is sampled and a new period (PERIOD) is calculated according to Equation 1 above. As a result, successive clock signals for the PWM frame are frequency modulated based on the measured voltage of V_{in} .

In the event that an end of the PWM frame is detected, the count value is compared to a predetermined targeted count value (T_COUNT) as shown in block 880. If the count value is greater than T_COUNT, the period of the power cycle is increased by a first amount of time ($\Delta T1$) as shown in block 885. In contrast, if the count value is less than T_COUNT, the period of the power cycle is decreased by a second amount of time ($\Delta T2$), where $\Delta T1$ may or may not be equal to $\Delta T2$ (block 890). If the count value is equal to T_COUNT, the period remains unchanged (block 892). For all of these determinations, the method of operation returns to block 855 after the clock counter is reset and the beginning of a new power cycle is monitored.

FIG. 9 is a second exemplary embodiment of light source controller 120 operating with the dimmer switch to control a light source in order to emulate lighting from a candle flame and of the signaling received and produced by the light source controller. As shown, for this embodiment, light source controller 120 comprises power regulation and conditioning logic 900, a fixed frequency oscillator 910, candle emulation control logic 620, power signal compensation logic 920 and driver logic 630.

As previously described, the first exemplary embodiment of light source controller 120 (FIG. 6) involved generation of a frequency modulated clock based on characteristics of the input power waveform and supplied the clock to candle emulation control logic 620 to produce appropriate PWM signals to driver logic 630. In contrast, the second exemplary embodiment as described below features fixed frequency oscillator 910 being used to clock candle emulation control logic 620 and separate circuitry, namely power signal compensation logic 920, to adjust the timing of the PWM signals applied to driver logic 630.

Herein, according to one embodiment of the invention, power regulation and conditioning logic 900 receives an input power waveform (V_{in}) 905 and Ground signaling (GND). V_{in} 905 may be DC power or AC power at approximately seventy-five percent (75%) as shown. Power regulation and conditioning logic 900 produces both regulated low voltage power 907 (e.g., 5V, 12V, etc.) and unregulated voltage power 908, as well as supplies GND 909. Regulated low voltage power 907 is supplied to oscillator 910, candle emulation control logic 620 and driver logic 630. Unregulated voltage power 908 is supplied to light source 110. GND 909 is applied to oscillator 910, candle emulation control logic 620, power signal compensation logic 920, driver logic 630 and light source 110.

In contrast with the operations of FIG. 6, power regulation and conditioning logic 900 provides information 930 on the timing of the turn-on and turn-off points of components within the dimmer switch (e.g., triac component) to power signal compensation logic 920. A fixed or constant frequency clock signal 915 is provided from oscillator 910 to candle emulation control logic 620, which provides values 932 that are used to identify a particular amount of voltage applied to light source 110.

Power signal compensation logic 920 receives values 932, and in combination with timing information 930 supplied by power registration and conditioning logic 900, outputs pulse width modulated (PWM) signals 935 to driver logic 630. PWM signals 935 are used to activate and deactivate components of driver logic 630 in order to emulate lighting from a candle flame. For this embodiment, power signal compensa-

tion logic 920 is outputting PWM signals at 50/50 duty cycle (e.g., every power half-cycle at 120 HZ if V_{in} is 60 HZ AC power).

Referring still to FIG. 9, a detailed perspective of a power cycle of input power waveform (V_{in}) and certain resultant signals produced by components of light source controller 120 are shown. As illustrated, waveform 940 is a segment of a single power cycle of V_{in} 905. Waveform 930 is a signal from power regulation and conditioning logic 900 that provides information on the timing of the turn-on and turn-off points of a triac component to power signal compensation logic 920.

As further shown, the actual output to driver logic 630 where, in a first region 950 of PWM signal 935, a selected component (e.g., triac) in the dimmer switch is inactive. However, driver logic 630 continues to receive power and allow current to pass through light source 110 so that the RC charging circuit in the dimmer continues to operate. As soon the triac component is set at second region 952, the candle emulation control logic 620 waits for a programmed time period (e.g., $\frac{7}{15}$ of power half-cycle) until light source 110 is to be turned off. At that time, power is turned off and an appropriate amount of time is waited until the power is turned on (e.g., around zero-crossing of input power waveform 940).

It is important to note that the waveforms applied to driver logic 630 are substantially equivalent as the waveforms applied to driver logic of FIG. 6. It occurs at a point that light source controller 120 has knowledge of power input waveform 905 and adjusts the output accordingly.

As set forth below, Equation 2 illustrates a first exemplary embodiment of the operations performed by the power regulation and conditioning circuitry 900 of FIG. 9. This embodiment involves the computation of "x" for each clock cycle, where "x" identifies when power is disconnected from the light source.

EQUATION 2:

T_{on} =point in time when dimmer triac turns on
 x =point at which power is disconnected from bulb
 T =period of AC waveform, for 60 Hz, 16666 ms
 n =PWM value for this frame
 N =total PWM values in a frame, i.e. for 4-bit PWM, values can be 0-15, so $N=16$.

$$\int_{T_{on}}^x \sin(\omega t) dt = n/N \int_{T_{on}}^{T/2} \sin(\omega t) dt$$

$$\omega = 2\pi/T$$

By adjusting the integral boundaries, the following is obtained:

$$\int_y^{T/2-T_{on}} \sin(\omega t) dt = n/N \int_0^{T/2-T_{on}} \sin(\omega t) dt$$

$$y = T/2 - x$$

$$\omega = 2\pi/T$$

Now remember that

$$\int \sin(\omega t) dt = -1/\omega \cos(\omega t)$$

$$\cos(0) = 1$$

$$\cos(\pi) = -1$$

$$\cos(2\pi) = 1$$

15

To solve this equation for y :

$$\begin{aligned} -1/\omega \cos(\omega t) \Big|_y^{T/2-Ton} &= -n/N \omega \cos(\omega t) \Big|_0^{T/2-Ton} \\ y &= 1/\omega * a \cos \left[\left(1 - \frac{n}{N}\right) \cos(\omega(T/2 - Ton)) + \frac{n}{N} \right] \\ x &= T/2 - 1/\omega * a \cos \left[\left(1 - \frac{n}{N}\right) \cos(\omega(T/2 - Ton)) + \frac{n}{N} \right] \end{aligned}$$

For verification, we know

$$\begin{aligned} 0 &\leq Ton \leq T/2 \\ \Rightarrow T/2 &\geq T/2 - Ton \geq 0 \\ \Rightarrow 1 &\geq \cos(\omega(T/2 - Ton)) \geq -1 \end{aligned}$$

As Ton ranges from 0 to $T/2$

At $Ton=0$:

$$\begin{aligned} x &= T/2 - 1/\omega * a \cos \left[\frac{2n - N}{N} \right] \\ n = 0 &\rightarrow x = 0 \\ n = N &\rightarrow x = T/2 \end{aligned}$$

And at $Ton=T/2$

$$x = T/2 - 1/\omega * a \cos(0) = T/2$$

FIG. 10A is an illustrative embodiment of power regulation and conditioning logic 900 operating with a dimmer controller to control the light source in order to emulate lighting from a candle flame. According to one embodiment of the invention, Power signal compensation logic 920 comprises one or more integrators 1000 (e.g., first and second integrators 1005 and 1010), a sample & hold circuit 1015, a divider (e.g., resistor ladder circuit, variable divider) 1020 and a comparator 1025. Integrators 1005 and 1010 may be implemented in software or in hardware (e.g., analog circuitry) and can be reset as needed. The analog inputs to both integrators 1005 and 1010 may be connected to the unregulated input power, V_{in} or alternatively to a regulated, rectified, protected and/or scaled version of V_{in} .

According to one embodiment, as further shown in FIG. 10B, first integrator 1005 is adapted to measure voltage available over a 50/50 duty cycle (e.g., over an entire power half-cycle). Second integrator 1010 is adapted to measure up to a predetermined ratio (X/Y , where "X" and "Y" are integers and $X \leq Y$) of voltage available during the power half-cycle. In other words, second integrator 1010 is used to measure a ratio of overall power available (e.g., $1/16^{th}$ of V_{in} , where $X=1$, $Y=16$) as measured in a prior power half-cycle by first integrator 1005. Hence, the output of second integrator 1010 is more compressed and has a lesser amplitude than signaling measured at the output of first integrator 1005.

In general, first and second integrators 1005 and 1010 can collectively map out equal amounts of voltage through integration of a function based on an input power waveform (V_{in}) and time (t). The sampled, integrated voltage originating from first integrator 1005 is subsequently divided out by divider 1020 for comparison with the voltage measured by second integrator 1010. Of course, it is contemplated that first integrator 1005 may be adapted as a "X/Y" integrator to allow removal of divider 1020.

As shown in FIG. 10A, when triggered by a sample pulse 1017, sample & hold circuit 1015 samples an output signal of

16

first integrator 1005 and holds it on its output 1019. Hence, every time sample pulse 1017 is asserted, sample & hold circuit 1015 measures the resultant output of first integrator 1005 at that time. As a result, use of first integrator 1005 with sample & hold circuit 1015 is an iterative process where V_{in} undergoes integration, a sample is measured and then first integrator 1005 receives a reset signal 1030 to restart integration for the next power half-cycle.

Comparator 1025 identifies when the output of second integrator 1010 is equivalent to the predetermined ratio (X/Y) of the total power as measured first integrator 1005, namely when a particular data points on the time axis in FIG. 5 is reached. Thereafter, the process repeats for the next time slice of the input power waveform V_{in} .

FIG. 10B is an exemplary embodiment of the operations performed by power regulation and conditioning circuitry 900 of FIG. 9. These operations are performed every power cycle (e.g., 60 Hz) rather than every clock cycle, reducing the process intensity.

Herein, a first waveform 1050 is a selected duty cycle of an input power waveform (V_{in}) where the dimmer has not been adjusted during this time frame. Second waveform 1060 is the resultant output measured on first integrator 1005, which is the result of integrating the power available on a power half-cycle previous to the power half-cycle at which second integrator 1010 is operating.

Waveform 1065 represents a sampled output representing an instantaneous voltage measured for the end of a power half-cycle and is held for comparison with the measured voltage by second integrator 1010. This sampled output is held at the output 1019 of sample & hold circuit 1015 of FIG. 10A, which occurs approximate to the end of each power half-cycle. Hence, as shown herein, sample pulse 1017 occurs prior to reset signal 1030 for first integrator 1005. This provides a steady value on sample and hold circuit 1015 from which to compare.

As shown, the resulting output of second integrator 1010 occurs at a much higher frequency because a lesser output value needs to be realized before reset signal 1035 is set. Moreover, as the voltage amplitude of V_{in} increases, the rate of integration increases in speed.

Waveform 1070 is the output of comparator 1025 of FIG. 10A, which indicates that that saw-tooth waveform output measured by second integrator 1010 has reached $1/16$ of the total voltage of input power waveform (V_{in}) measured by integrator 1005. As a result, the output is logic high to indicate the following: (1) the output 1075 of second integrator has reached $1/16^{th}$ of the total voltage of input power waveform (V_{in}), and (2) second integrator 1010 needs to be reset 1035. As soon as second integrator 1010 is reset, the output drops to zero again and starts ramping up again.

FIG. 11A is an exemplary flowchart of the operations of the power regulation and conditioning logic of FIG. 9. In order to maintain the flow of operations, an interrupt should be generated upon detection of a zero crossing (block 1100). This may be accomplished by a variety of mechanisms. For instance, the zero crossing may be detected by implementing a zero crossing detector within power regulation and conditioning circuitry 900 of FIG. 9. Alternatively, the zero crossing may be detected by code executing on a processing logic in communication with power regulation and conditioning logic 900 of FIG. 9.

If this is the first zero crossing detected, an interrupt is generated to cause a secondary operation to occur (block 1105). Otherwise, the operations continue to monitor for a zero crossing.

As shown in FIG. 11B, an exemplary flowchart of the operations of the power regulation and conditioning logic of FIG. 9 upon detection of a zero crossing is shown. Upon detection of a zero crossing and initiation of the interrupt, the sample & hold circuitry samples the total voltage of a previous input power waveform (blocks 1110 and 1115). The first and second integrators are reset, so as to begin integration for this power cycle (blocks 1120 and 1125).

Now, the second integrator commences integration until it achieves an output equal to X/Y (e.g., $1/16$ of the output of first integrator). At that time, the comparator outputs a logic high signal and a counter is incremented (blocks 1130 and 1135). The counter is used to control activation and deactivation of the light source for a given pulse width modulated frame and to track the position within the PWM frame. In particular, the counter controls the light source such that if the count is equal to one and it is desired that the light source be illuminated $1/16^{th}$ of the time, certain filament segments of the light source are turned on. Then, a determination is made whether the maximum count has been reached (block 1140). If the counter has not reached the maximum count, the second integrator is reset and commences integration again as set forth in blocks 1125-1140. If we have reached the maximum count, a waiting period occurs until a new interrupt is issued (block 1145).

FIG. 12 is a third exemplary embodiment of light source controller 120 operating with the dimmer control to control light source 110 in order to emulate lighting from a candle flame and of the signaling received and produced by light source controller 120. As shown, for this embodiment, light source controller 120 comprises power regulation and conditioning logic 1200, synchronized oscillator 1210, candle emulation control logic 620 and driver logic 630.

As shown, power regulation and conditioning logic 1200 receives an input power waveform (V_{in}) 1250 and Ground signaling (GND). V_{in} may be DC power or AC power as shown. Power regulation and conditioning logic 1200 produces both regulated low voltage power 1202 (e.g., 5V, 12V, etc.) and unregulated voltage power 1204, as well as supplies GND 1206. Regulated low voltage power 1202 is supplied to synchronized oscillator 1210, candle emulation control logic 620 and driver logic 630. Unregulated voltage power 1204 is supplied to light source 110. GND 1206 is applied to synchronized clock 1210, candle emulation control logic 620, driver logic 630, and light source 110.

Herein, synchronized oscillator 1210 applies a substantially constant clock 1215 to candle emulation control logic 620. Clock 1215 may have a fixed number of clock cycles per power half-cycle (e.g., 240 clock cycles per power half-cycle). Synchronized oscillator 1210 may be separate from or integrated within candle emulation control logic 620.

Unlike other embodiments, at no point does any component of light source controller 120 need information regarding the voltage amplitude of input power (V_{in}). Instead, during each cycle of the input power waveform, V_{in} is divided into small segments of time during which the input power appears to be linear or constant between neighboring segments.

A first waveform 1250 is an input power (V_{in}) waveform, which is approximately a 75% duty cycle. An expanded version of a single power cycle is further shown below. Although shown as a AC sinusoidal waveform, it is contemplated that waveform 1250 may be a modulated power waveform with a high frequency carrier with appropriate amplitude modulation with polarity switching.

A second waveform 1255 features values produced internally within candle emulation control logic 620, which are used to identify a particular amount of voltage applied to the load.

Regarding a third waveform 1260, a falling edge 1262 of second waveform 1260 is illustrated along with the shaded area 1264 of waveform 1260, which merely represents that the structure of second waveform 1260 is not critical to the operations of the candle emulation device. Only a periodic reference of waveforms for each power half-cycle, such as the timing between falling edges of neighboring waveforms is pertinent information provided by power regulation and conditioning logic 1200.

A fourth waveform 1270 is a high frequency clock signal that is synchronized to the input power and maintains a fixed (and perhaps constant) number of cycles unless the frequency of V_{in} is altered. In essence, small slices of input power waveform 1250 over time are being taken and input power waveform 1250 is not changing that much over each slice. Thus, input power waveform 1250 appears as a DC signal that is pulse width modulated. Unlike FIG. 6, there is no clock adjustment for the amplitude of V_{in} because candle emulation control logic 620 is updating once every power half-cycle.

A fifth waveform 1280 features the output PWM signals applied to light source 110. These output PWM signals are equal in width and change based on modifications of values within second waveform 1255. As shown, first power half-cycle 1252 is divided into Z (e.g., $Z \geq 16$) segments where the output PWM signals are repeated for each segment. In other words, for the first power half-cycle, a first PWM signal 1282 would represent $1/Z^{th}$ of the total time associated with the particular time slice ($T/2Z$). “ Z ” is chosen based on a number of constraints: (1) intermittent application of power to the load is fast enough to avoid the dimmer being accidentally turned off (e.g., triac component turned off); (2) sufficient in number so that there is substantially equal power levels between neighboring segments; (3) minimal in number to avoid an unnecessarily high driver logic activation and deactivation frequency, which causes inefficient power consumption.

FIG. 13 is an exemplary block diagram illustrating mode switching at least partially controlled by light source controller 120 of FIG. 1. Light source controller 120 is adapted to place light source 110 in a variety of lighting modes. These lighting modes may include, but are not limited or restricted to one or more candle modes and/or one or more non-candle modes. Of course, it is contemplated that light source controller 120 may have a single mode of operation with multiple sub-modes as described.

In general, a “first mode” (non-candle mode) involves substantially constant illumination, which is the typical lighting effect produced by lighting fixtures using incandescent light bulbs (i.e. constant lighting). The first mode may have one or more sub-modes, each of which represents different illumination levels (dim/brightness levels), which may be useful for dimmer application or power savings.

A “second mode” (candle mode) is a mode of operation that emulates the lighting effect produced by a candle flame. More specifically, the second mode may also include one or more sub-modes, each representing a different type of lighting pattern produced by a candle flame. For instance, various candle (emulation) sub-modes may produce lighting patterns representing a glowing lighting effect, a flickering lighting effect (e.g., windy —candle in high wind with increased flickering rate; calm —candle in low wind with minimal flickering rate, etc.), a random lighting effect, a pulsating lighting effect where the light intensity routinely changes

dramatically, a shifting effect where the physical location of the light appears to vary, or the like. It is contemplated that lighting modes and sub-modes described herein are merely illustrative, and not restrictive. Other lighting modes and sub-modes may be utilized by the invention.

The placement of light source controller **120** into a first mode or a second mode may be controlled by a switching mechanism **1300** accessible to the consumer. Examples of switching mechanism **1300** may include, but are not limited or restricted to a dimmer/light switch, a separate manual switch, a remote control or the like. For instance, the separate manual switch may be located on the housing of a lighting fixture (candle emulation device) **1310** that is implemented with light source controller **120**. A consumer manually adjusts switching mechanism **1300** to signal candle emulation control logic (CECL) **620** of light source controller **120** as to the desired lighting mode.

For instance, switching mechanism **1300**, when implemented as a light switch, may be turned on/off, perhaps multiple times, in order to program a default lighting mode, and/or place light source **110** into a particular lighting mode. The programming of the default lighting mode may be to any available lighting mode, regardless of the lighting mode that was previously used.

Based on the chosen setting of switching mechanism **1300** corresponding to a chosen mode of operation, CECL **620** generates a particular sequence of values that are subsequently used by CECL **620** as shown or perhaps power compensation logic of FIG. 9, to produce PWM output signals applied to driver logic **630**. These PWM output signals are used to control activation and deactivation of filament segment(s) of light source **110**, which produces the selected lighting effect.

Alternatively, switching mechanism **1300** may control placement of light source controller **120** into a first mode or second mode by a cyclical setting of the lighting modes. For instance, lighting fixture **1310** operates in a first mode and, upon an occurrence of a mode-switching event, lighting fixture **1310** may be configured to operate in another mode or a particular sub-mode. As an example, upon re-occurrence of a mode-switching event, candle emulation device **1310**, previously operating in a first mode, now operates in a second sub-mode of the second mode. Hence, the selection of the lighting modes is performed serially and is dependent on either the prior lighting mode used or a selected default lighting mode (where a consumer selects how a light should respond whenever it is turned on from being off for a short amount of time).

Herein, a "mode-switching event" is any action that causes a change of state from one lighting mode to another. For instance, manual adjustment of a switch or dial associated with lighting modes placed on candle emulation device **1310** constitutes a mode-switching event. Additionally, pushing a button placed on lighting fixture **1310** to sequentially alter the lighting mode constitutes a mode-switching event. As another example, causing an interrupt in power (turning off/on a lighting fixture within selected period of time, or lowering the duty cycle of a dimmed input power wave to a certain threshold, followed by raising it) constitutes a mode-switching event. Also, control signaling from external control logic or even a solar cell, as X10 signaling over power line, or RF signal over air constitutes a mode-switching event.

Although not shown, it is further contemplated that a single light source (e.g., light source **110** of FIG. 1) may be controlled by both light source controller **120** when candle emulation is desired or by other components when normal incandescent lighting (i.e., substantially constant illumination) is

desired. More specifically, implemented within a lighting fixture, switching logic may be configured to support three or more operational states. A first state is an OFF state where light source **110** is not illuminated. The switching logic may be placed in a second state where a light source controller (as described above) is adapted to control the mode of operation of light source **110** in order to emulate the lighting effect produced by a candle flame. In addition, the switching logic may be placed in a third state where power is directly supplied to light source **110** bypassing the light source controller. In the third state, the light source provides substantially constant illumination. The switching logic would be controlled and placed into one of these operational states through use of a switching mechanism as described above.

Also, it is further contemplated that multiple light sources within a single lighting fixture may be separately controlled by a light source controller (defined above) and other components that are adapted to control and enable substantially constant illumination. For this configuration, one or more switches (located internally within the lighting fixture and/or externally within a wiring scheme) support three operational states. A first state is an OFF state where neither of the light sources is illuminated. A second state is where the light source controller is allowed to control the mode of operation of a first light source in order to emulate the lighting effect produced by a candle flame. Finally, a third state supplies power to enable substantially constant illumination of a second light source. Hence, when the lighting fixture is operational, the switch is controlled so that either the first light source provides illumination that emulates the lighting effect of a candle flame or the second light source provides substantially constant illumination (normal incandescent lighting).

While the invention has been described in terms of several embodiments, the invention should not be limited to only those embodiments described, but can be practiced with modification and alteration within the spirit and scope of the appended claims. The description is thus to be regarded as illustrative instead of limiting.

What is claimed is:

1. A method comprising:

receiving a time-varying power waveform; and
outputting a pulse width modulated (PWM) signal to a light source in order to produce a lighting effect emulating lighting from a candle flame, the PWM signal being synchronized with the time-varying power waveform, the outputting of the PWM signal comprises
producing a control signal based on the time-varying power waveform, and
producing the PWM signal based on the control signal, the PWM signal activates and deactivates components of a driver logic in order to control the light source into producing the lighting effect.

2. The method of claim 1, wherein the outputting of the PWM signal further comprises producing a clock signal based on the control signal and producing the PWM signal based on the clock signal.

3. The method of claim 1, wherein the PWM signal is altered based on a signal output from a dimmer switch.

4. The method of claim 1, wherein the PWM signal is synchronized and compressed within the time-varying power waveform.

5. The method of claim 1, wherein the producing of the clock signal includes modulating a frequency of the clock signal by the control signal.

6. The method of claim 1, wherein the producing of the clock signal includes modulating a frequency of the clock signal by the input power waveform.

21

7. The method of claim 6, wherein the PWM signal based on the clock signal is produced by a candle emulation control logic being an application specific integrated circuit (ASIC).

8. The method of claim 1, wherein the outputting of the PWM signal further comprises:

producing regulated power by power regulation and conditioning logic, the regulated power being supplied to a clock source adapted to produce the clock signal, a candle emulation control logic adapted to produce the PWM signal, and the driver logic.

9. The method of claim 8, wherein the outputting of the PWM signal further comprises:

producing unregulated power by the power regulation and conditioning logic, the unregulated power being the supplied to the light source.

10. A method comprising:

receiving a time-varying power waveform; and

outputting a pulse width modulated (PWM) signal to a light source in order to produce a lighting effect emulating lighting from a candle flame, the PWM signal being synchronized with the time-varying power waveform, wherein the outputting of the PWM signal comprises:

producing timing information based on the time-varying power waveform,

producing values that are used to identify a particular amount of power applied to the light source based on a constant frequency clock signal, and

producing the PWM signal based on the values and the timing information.

11. The method of claim 10 further comprising:

using the PWM signal to control components of driver logic that controls activation of the light source.

12. A method comprising:

receiving a time-varying power waveform; and

outputting a pulse width modulated (PWM) signal to a light source in order to produce a lighting effect emulating lighting from a candle flame, the PWM signal being synchronized with the time-varying power waveform, the outputting of the PWM signal comprises:

producing a first waveform being a high frequency clock signal that is synchronized to the time-varying power waveform,

producing a second waveform including values to identify a particular amount of power applied to the light source, and

producing output PWM signals forming the PWM signal, the output PWM signals are equal in width and change based on modifications of values within second waveform.

13. A candle emulation device comprising:

a light source; and

a light source controller coupled to the light source, the light source controller to receive a time-varying power waveform and to produce a pulse width modulated (PWM) signal that is used to control the light source in order to produce a lighting effect that emulates lighting from a candle flame, the light source controller comprises:

power regulation and conditioning logic to provide regulated, local power from unregulated input power,

candle emulation control logic coupled to the power regulation and conditioning logic, the candle emulation control logic to produce a sequence of signals to create the lighting effect, and

driver logic coupled to the power regulation and conditioning logic and the candle emulation logic, the

22

driver logic to control the light source based on the sequence of signals supplied by the candle emulation control logic.

14. The candle emulation device of claim 13, wherein the light source controller is adapted to place the light source into a first mode where the lighting effect emulates lighting from a candle flame and a second mode where the light source has substantially constant illumination.

15. The candle emulation device of claim 13 further comprising a power source at least coupled to the light source controller to supply the unregulated input power.

16. The candle emulation device of claim 13, wherein the driver logic to activate or deactivate different filament segments of the light source.

17. The candle emulation device of claim 13, wherein the light source comprises:

a bulb housing including a translucent material surrounding a plurality of filament segments, the bulb housing includes a first closed end and a second open end including an elongated protrusion formed proximate to a perimeter of the second open end to create a channel;

a plurality of feedthroughs coupled to the plurality of filament segments and extending through the second open end of the bulb housing; and

a base interlocking with the channel of the bulb housing and being coupled to the light source controller, the base including a first plurality of grooves alternatively positioned on a top and bottom surfaces of the base to expose multiple locations of surface area of the plurality of feedthroughs.

18. The candle emulation device of claim 13 being a chandelier with the light source controller positioned within a frame of the chandelier and producing the PWM signal to control multiple light sources each producing a lighting effect that emulates lighting from the candle flame.

19. The candle emulation device of claim 13, wherein the time-varying power waveform being an output from a dimmer switch external to the candle emulation device.

20. A candle emulation device comprising:

a light source; and

a light source controller coupled to the light source, the light source controller to receive a time-varying power waveform and to produce a pulse width modulated (PWM) signal that is synchronized with the time-varying power waveform in order to produce a lighting effect that emulates lighting from a candle flame, the light source controller comprises:

a power regulation and conditioning logic to produce a control signal based on the time-varying power waveform,

a power signal modulated clock coupled to the power regulation and conditioning logic, the power signal modulated clock to produce a clock signal based on the control signal,

a driver logic to electrically coupled to the light source, and

a candle emulation control logic coupled to the power signal modulated clock and the driver logic, the candle emulation control logic to produce the PWM signal based on the clock signal, the PWM signal activates and deactivates components of the driver logic in order to control the light source into producing the lighting effect.

21. The candle emulation device of claim 20, wherein the light source controller to receive the time-varying power waveform from a dimmer switch external to the candle emulation device.

23

22. A candle emulation device comprising:
 a light source; and
 a light source controller coupled to the light source, the
 light source controller to receive a time-varying power
 waveform and to produce a pulse width modulated
 (PWM) signal that is synchronized with the time-vary- 5
 ing power waveform in order to produce a lighting effect
 that emulates lighting from a candle flame, the light
 source controller comprises:
 a power regulation and conditioning logic to produce a 10
 timing information based on the time-varying power
 waveform,
 a clock to produce a clock signal with a fixed clock
 frequency,
 a driver logic to electrically coupled to the light source, 15
 a candle emulation control logic coupled to the clock
 and the driver logic, the candle emulation control
 logic to producing values that are used to identify a
 particular amount of power applied to the light source 20
 based on the clock signal, and
 a power signal compensation logic coupled to the power
 regulation and conditioning logic and the candle emu-
 lation control logic, the power signal compensation
 logic to produce the PWM signal based on the values
 and the timing information.

24

23. The candle emulation device of claim 22, wherein the
 light source controller to receive the time-varying power
 waveform from a dimmer switch external to the candle emu-
 lation device.

24. A candle emulation device comprising:
 a light source; and
 a light source controller coupled to the light source, the
 light source controller to receive a time-varying power
 waveform and to produce a pulse width modulated
 (PWM) signal that is synchronized with the time-vary-
 ing power waveform in order to produce a lighting effect
 that emulates lighting from a candle flame, the light
 source controller comprises:
 a driver logic to electrically coupled to the light source, and
 a candle emulation control logic coupled to the driver logic, 15
 the candle emulation control logic to produce output
 PWM signals forming the PWM signal, the output
 PWM signals are substantially equal in width for each
 power half-cycle and are used to control the light source
 to produce the lighting effect.

25. The candle emulation device of claim 24, wherein the
 light source controller to receive the time-varying power
 waveform from a dimmer switch external to the candle emu-
 lation device.

* * * * *