

F. W. COLE.  
 SUPERVISORY SIGNALING DEVICE FOR CLOCKS,  
 APPLICATION FILED APR. 15, 1910.

997,603.

Patented July 11, 1911.

3 SHEETS—SHEET 1.

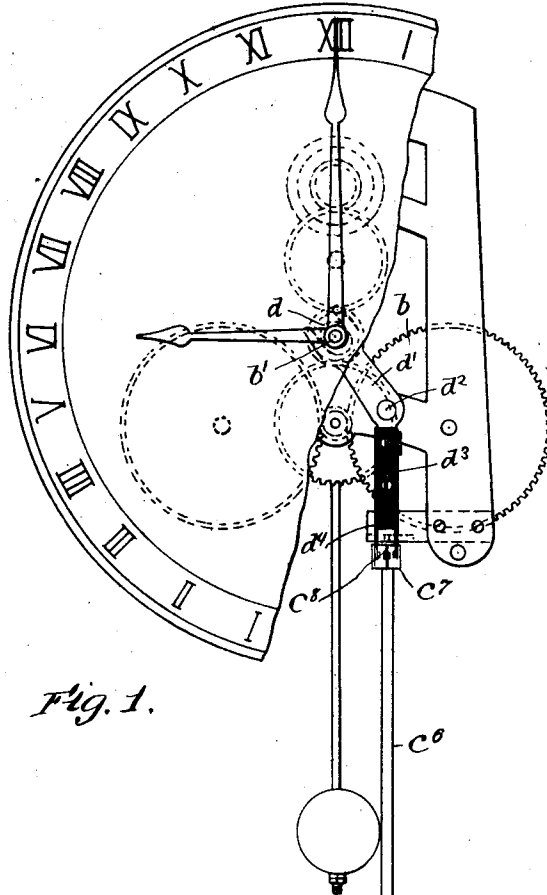

Fig. 1.

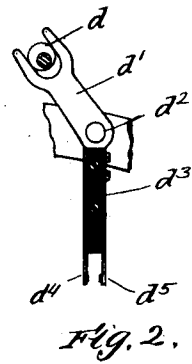

Fig. 2.

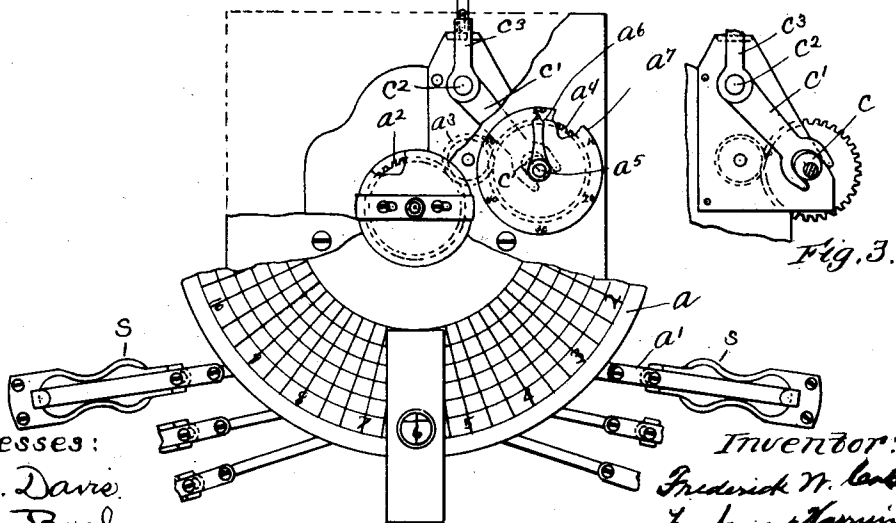

Fig. 3.

Witnesses:  
 H. B. Davis  
 H. A. Boyle

Inventor:  
 Frederick W. Cole  
 by *Hayes & Hamman*  
 attys.

F. W. COLE.

SUPERVISORY SIGNALING DEVICE FOR CLOCKS.  
APPLICATION FILED APR. 15, 1910.

997,603.

Patented July 11, 1911.

3 SHEETS—SHEET 2.

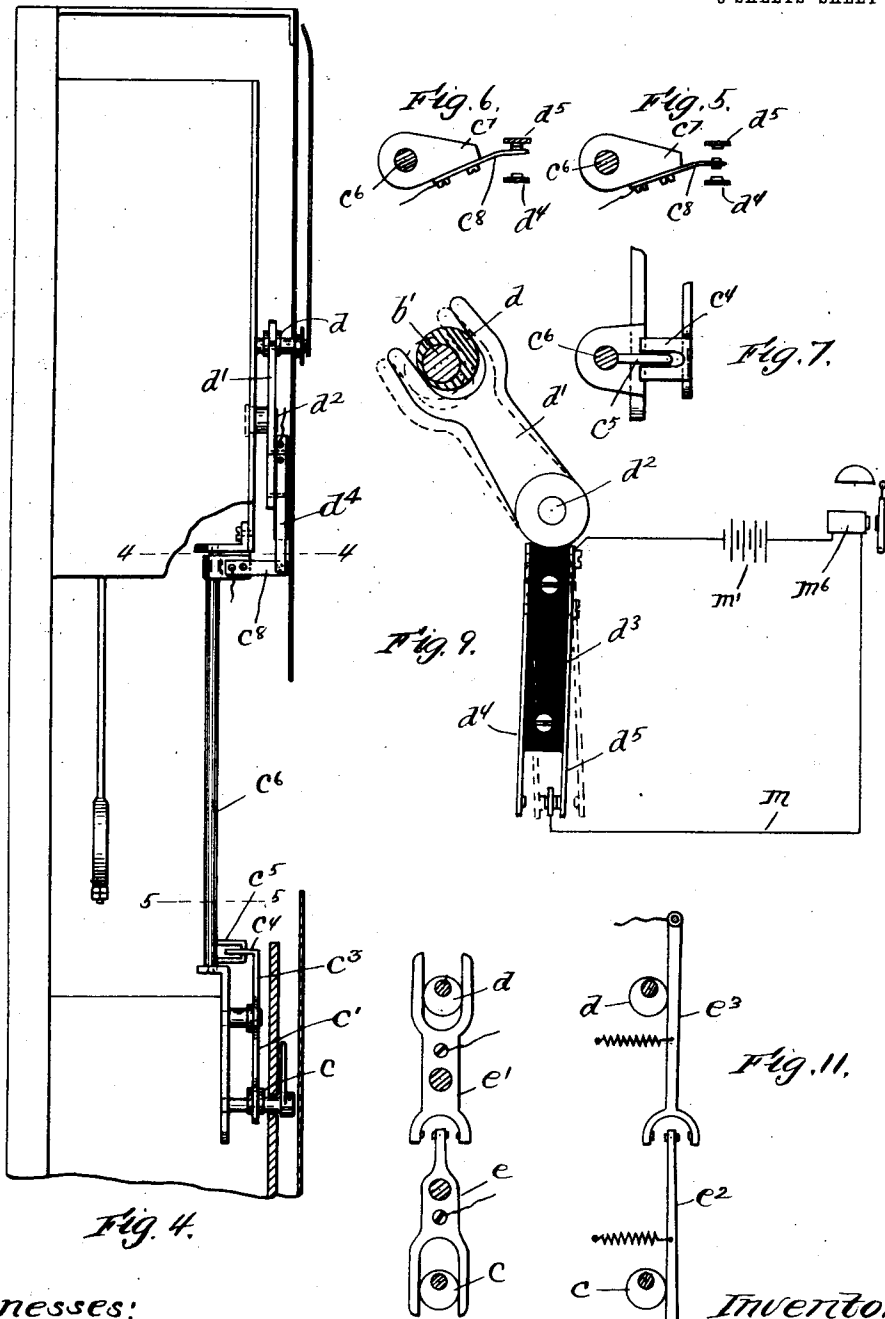

Witnesses:  
H. B. Davis,  
H. A. Boyle.

Fig. 10.

Inventor:

Frederick W. Cole  
by Kruger & Hanniman  
Attys.

F. W. COLE.  
 SUPERVISORY SIGNALING DEVICE FOR CLOCKS.  
 APPLICATION FILED APR. 15, 1910.

997,603.

Patented July 11, 1911.

3 SHEETS—SHEET 3.

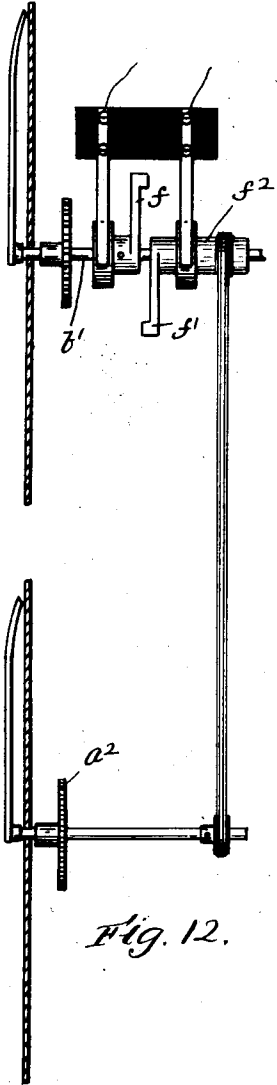

Fig. 12.

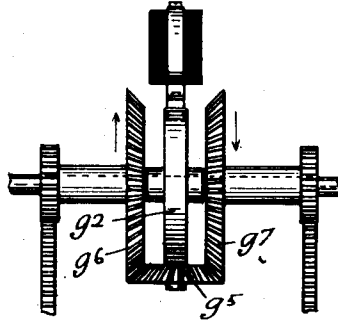

Fig. 13.

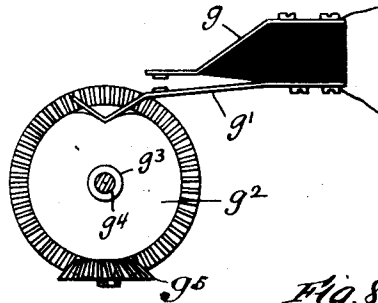

Fig. 14.

Fig. 8.

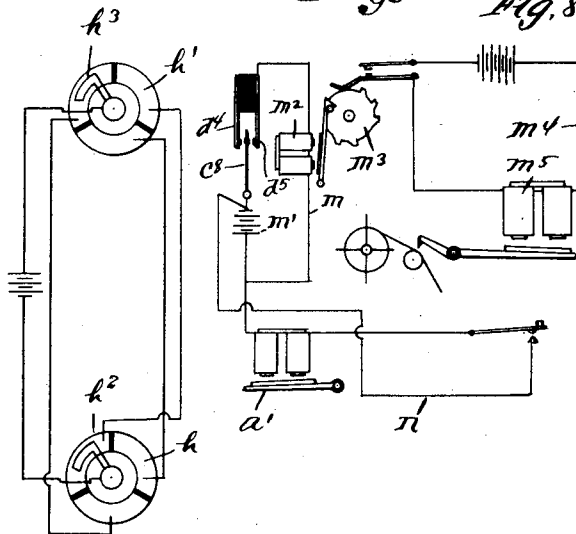

Fig. 15.

Witnesses:  
 H. B. Davis,  
 H. K. Boyle.

Inventor:  
 Frederick W. Cole  
 by Hayes & Harrison  
 Attys.

# UNITED STATES PATENT OFFICE.

FREDERICK W. COLE, OF NEWTON, MASSACHUSETTS, ASSIGNOR TO THE GAMEWELL  
FIRE ALARM TELEGRAPH COMPANY, OF NEW YORK, N. Y., A CORPORATION OF NEW  
YORK.

SUPERVISORY SIGNALING DEVICE FOR CLOCKS.

997,603.

Specification of Letters Patent. Patented July 11, 1911.

Application filed April 15, 1910. Serial No. 555,896.

To all whom it may concern:

Be it known that I, FREDERICK W. COLE, of Newton, in the county of Middlesex and State of Massachusetts, have invented an  
5 Improvement in Supervisory Signaling Devices for Clocks, of which the following is a specification.

This invention relates to supervisory signaling-devices for clocks or other timing-mechanisms, and has for its object to provide a signaling-device adapted to be operated to cause a notification signal to be given or transmitted to a central-station, especially in case the clock or other timing-mechanism becomes disabled. It is of  
15 especial value in connection with automatic fire-alarm and watchman's supervisory signal-systems in which the continual operation of timing-devices is depended upon for sending signals or causing signals to be sent, and also for recording the signals. The invention is also applicable to other systems and apparatus embodying a timing-mechanism, when it is desired that notification  
20 shall be given when said mechanism becomes disabled or runs too fast or too slow.

The invention consists in embodying a timed-supervisory-mechanism in connection with the timing-mechanism, and a signaling-device for indicating the stopping of the timing-mechanism, or of either the timing-mechanism or the timed-supervisory-mechanism, and also for indicating when the timing-mechanism and timed-supervisory-mechanism are running out of synchronism, so that in case of any trouble whereby the timing-mechanism is disabled or its control affected, notification will be  
30 given.

A signaling-device is preferably employed and its circuit is adapted to be operated or controlled by the joint action of said timing-mechanism and timed-supervisory-mechanism, so that it may be operated by either, in case one ceases to operate, or in case they run out of synchronism. The signaling-device employed will preferably be a code-signal transmitter, and in such case several may be connected in a  
40 single circuit connected with a central-station, and when more than one transmitter is employed different identification signals will be sent. The code-signal transmitter is adapted to be released or otherwise operated.  
55

Figure 1 is a front view of a sufficient portion of a watchman's clock to illustrate this invention, together with means embodying this invention for operating a signaling-device in case said clock stops or runs  
60 too fast or too slow. Figs. 2 and 3 are details to be referred to. Fig. 4 is a side view of the parts shown in Fig. 1. Figs. 5, 6 and 7 are details to be referred to. Fig. 8 is a diagram of the circuit to be referred to. Fig. 9 is an enlarged detail of one of the contact-members, together with a diagram  
65 of a circuit having a modified form of signaling-device, and, Figs. 10 to 15 inclusive are details showing modified forms of circuit-operating devices for the circuit of the signaling-device.

$a$  represents the removable dial of any usual or suitable watchman's clock, or equivalent timing-mechanism, and  $a'$  one of several  
75 electro-magnetically operated markers for marking or puncturing the dial or otherwise indicating a signal thereon in response to the operation of a circuit, such as  $n$ , Fig. 8, by a watchman.

$a^2$  represents a toothed wheel which may be secured to the minute-shaft of the timing-mechanism, which is engaged by an idle pinion  $a^3$ , which in turn engages a  
80 toothed wheel  $a^4$ , secured to a shaft  $a^5$ , so that said toothed wheel  $a^4$  revolves in synchronism with the toothed wheel  $a^2$ , making a complete revolution once an hour. A hand  $a^6$  is secured to the shaft  $a^5$  which moves over a small dial  $a^7$ . With the exception of moving the minute hand  $a^6$  to one side of the center of the clock-train and mounting it on an independent shaft instead of connecting it with the shaft bearing the toothed wheel  $a^2$ , the timing-mechanism thus shown is constructed as the ordinary watchman's clock, but is here shown  
85 particularly for illustration. Hence my invention is not limited to any particular construction of timing-mechanism, or to the employment of a dial and cooperating devices whereby it is adapted to serve as a watchman's clock.

$b$  represents one of the train-wheels of a timed-supervisory-mechanism of any usual or suitable construction, and  $b'$  the minute-shaft thereof. A pendulum clock is here shown as the timed-supervisory-mechanism, merely for the purpose of illustration. Said  
90 timed-supervisory-mechanism is timed to  
100  
110

run in synchronism with the aforesaid timing-mechanism, and, as here shown, is designed to be employed as a controller for said timing-mechanism, and also to be controlled by said timing-mechanism. In carrying out this part of my invention, as shown in Figs. 1 to 9, the minute-shaft  $a^5$  of the timing-mechanism and the minute-shaft  $b'$  of the timed-supervisory-mechanism, each having secured to them a disk, and said disks, represented at  $c$  and  $d$ , respectively, are arranged eccentrically on their shafts and in the same relative positions. The eccentric disk  $c$  is embraced by the forked end of a lever  $c'$ , pivoted at  $c^2$ , and having an upwardly extended arm  $c^3$ , provided with a bifurcated laterally extended finger  $c^4$ , which embraces an ear  $c^5$ , arranged at the lower end of and projecting at right angles from an upright shaft  $c^6$ , supported by suitable end bearings, so that as the minute-shaft  $a^5$  revolves, said lever moves back and forth slowly on its pivot, making one complete vibration during each complete revolution of the minute-shaft, and the shaft  $c^6$  correspondingly reciprocates rotarily, moving through a short arc. The eccentric disk  $d$  is embraced by the forked end of a lever  $d'$ , pivoted at  $d^2$ , and having a downwardly extended arm  $d^3$ , composed of insulating material, which bears a pair of contact-pens  $d^4$ ,  $d^5$ , the ends of which are extended below the end of the arm and are spaced apart. As the shaft  $b'$  revolves the lever  $d'$  moves back and forth slowly on its pivot, making one complete vibration during each complete revolution of the disk and the arm  $d^3$  bearing the contact-pens correspondingly vibrates. The upper end of the reciprocating shaft  $c^6$  bears a short arm  $c^7$ , see Figs. 5, 6 and 7, which projects therefrom at right angles, and bears a contact-pen  $c^8$ , which projects into the space between the two contact-pens  $d^4$ ,  $d^5$ , and normally occupies a middle position therebetween.

Assuming the timing-mechanism and timed-supervisory-mechanism to be set at unison, and the contact-pen  $c^8$  disposed midway between the contact-pens  $d^4$ ,  $d^5$ , it will be seen that as long as they run in synchronism, the levers will be moved by the eccentric disks and the relative positions of the contact-pens  $d^4$ ,  $d^5$  and  $c^8$ , will remain unchanged, see Fig. 5, and the circuit  $m$  of the signaling-device will not be operated, but in case the timing-mechanism stops the contact-pen  $c^8$  will cease to move and will be soon overtaken by one of the contact-pens  $d^4$ , or  $d^5$ , and engagement effected, see Fig. 6, whereby the circuit  $m$  see Figs. 8 and 9, including said contact-pens will be operated, and in case the timed-supervisory-mechanism stops the contact-pens  $d^4$ ,  $d^5$ , will cease to move and one of them will be soon overtaken by the contact-pen  $c^8$ , and said circuit

$m$  operated. Or, in case either the timing-mechanism or timed-supervisory-mechanism runs out of synchronism with the other, as for instance, too slow or too fast, the contact-pen will be moved relatively to each other and into engagement to operate said circuit  $m$ . Thus the signaling-device is prevented from operation by the timing-mechanism and timed-supervisory-mechanism, acting conjointly, when running in synchronism, but is permitted or caused to operate whenever either stops or when they run out of synchronism, the means to operate said signaling-device being automatic.

The circuit  $m$ , includes a battery  $m'$ , and may include a releasing-magnet  $m^2$ , see Fig. 8, for a code-signal-transmitting-device  $m^3$ , whereby a code-signal, as for instance an identification-number, will be sent over a circuit  $m^4$ , which will operate the recorder  $m^5$ , or other signaling-device. In lieu of employing a recorder as a signaling-device, the circuit  $m$  may directly include a bell  $m^6$ , or other form of alarm apparatus, see Fig. 9. Thus, in case either the timing-mechanism or timed-supervisory-mechanism stops, or runs out of synchronism with the other, the signaling-device is operated to give notification of the trouble.

In lieu of the means above described for operating the signal-circuit, the form shown in Fig. 10 may be employed, wherein the aforesaid eccentric disks  $c$  and  $d$  are respectively arranged to directly operate pivoted levers  $e$  and  $e'$ , bearing electric contacts for the signal-circuit. Or the form shown in Fig. 11 may be employed wherein the eccentric disks  $c$  and  $d$  respectively operate spring-acting pivoted levers  $e^2$ , and  $e^3$ , bearing electric contacts for the signal-circuit. Or the form shown in Fig. 12 may be employed wherein one of the contact-pens, as  $f$ , for the signal-circuit, is connected with the minute-shaft of the timed-supervisory-mechanism, and its coöperating contact pen  $f'$  is connected to a sleeve  $f^2$  mounted on said shaft, and is operated by the minute-shaft of the timing-mechanism by a belt or other suitable means, said contact-pens being insulated from each other and arranged to engage each other in case either the timing-mechanism or timed-supervisory-mechanism stops or runs out of synchronism with the other. Or the form shown in Figs. 13 and 14, may be employed wherein one of the contact-pens, as  $g$ , for the signal-circuit is fixed and the other, as  $g'$ , is movable, and said movable contact-pen engages a cam-disk  $g^2$  arranged on a sleeve  $g^3$  on a shaft  $g^4$ , and said disk  $g^2$  bears a bevel pinion  $g^5$ , which is interposed between a pair of bevel-gears  $g^6$ ,  $g^7$ , one connected with the minute-shaft of the timing-mechanism and the other with the minute-shaft of the timed-supervisory-mechanism, so that in case either the timing-

mechanism or timed-supervisory-mechanism stops or runs out of synchronism with the other, said bevel-pinion  $g^5$  will travel around the bevel-gears, and the cam disk to which it is connected will be rotated to lift the contact-pen  $g'$  and operate the signal-circuit. Or the form shown in Fig. 15 may be employed, wherein two circularly arranged sets of contact-plates  $h$  and  $h'$ , are provided, one for the timing-mechanism and the other for the timed-supervisory-mechanism, over which move contact-pens or wipers  $h^2$ ,  $h^3$ , which are connected respectively with the minute-shafts of said timing-mechanism and timed-supervisory-mechanism, and said contact-pens are connected in the signal-circuit, as shown, so that said circuit may be operated by either wiper.

From the many modifications shown, it will be apparent that I do not desire to limit my invention to the particular means here shown for operating the signal-circuit, as long as said means is arranged and operated by either the timing-mechanism or timed-supervisory-mechanism, in case the other stops or runs out of synchronism.

I claim:—

1. The combination of a timing-mechanism and a timed-supervisory-mechanism, a signaling-device for indicating the stopping of either, and means, operated by both, acting conjointly, for preventing the operation of said signaling-device and operated by either, exclusively of the other, to operate said signaling-device, substantially as described.

2. The combination of a timing-mechanism and a timed-supervisory-mechanism, a signaling-device for indicating when they run out of synchronism, and means operated by both, acting conjointly, when running in synchronism to prevent the operation of said signaling-device and operated by either when running out of synchronism to operate said signaling-device, substantially as described.

3. The combination with a timing-mechanism, of a timed-supervisory-mechanism, a signaling-device for indicating the stopping of the timing-mechanism, and means operated by the timing-mechanism and timed-supervisory-mechanism, acting conjointly, for preventing the operation of said signaling-device and operated by the timed-supervisory-mechanism, when the timing-mechanism stops, to operate said signaling-device, substantially as described.

4. The combination with a timing-mechanism, of a timed-supervisory-mechanism, a signaling-device for indicating when the timing-mechanism is not running in synchronism with the timed-supervisory-mechanism, and means operated by the timing-mechanism and timed-supervisory-mechanism, acting conjointly, when running in

synchronism, to prevent the operation of said signaling-device and operated by the timed supervisory-mechanism when the timing-mechanism is running out of synchronism with the timed-supervisory-mechanism to operate said signaling-device, substantially as described.

5. The combination with a timing-mechanism, of a timed-supervisory-mechanism, a signaling-device for indicating the stopping of the timed-supervisory-mechanism, and means operated by the timing-mechanism and timed-supervisory-mechanism, acting conjointly, for preventing the operating of said signaling-device and operated by the timing-mechanism when the timed-supervisory-mechanism stops, to operate said signaling-device, substantially as described.

6. The combination with a timing-mechanism, of a timed-supervisory-mechanism, a signaling-device for indicating when the timed-supervisory-mechanism is not running in synchronism with the timing-mechanism, and means operated by the timing-mechanism and timed-supervisory-mechanism, acting conjointly, when running in synchronism to prevent the operation of said signaling-device, and operated by the timing-mechanism when the timed-supervisory-mechanism runs out of synchronism with the timing-mechanism, to operate said signaling-device, substantially as described.

7. The combination with timing-mechanism, of a timed-supervisory-mechanism, an electric signaling-device, a circuit therefor, a circuit-operating device for said circuit comprising two cooperating members, means connecting one of said members with the timing-mechanism, and means connecting the other member with the timed-supervisory-mechanism, said members being normally disengaged and adapted to engage each other when either ceases to operate, substantially as described.

8. The combination with a timing-mechanism, of a timed-supervisory-mechanism, an electric signaling-device, a circuit therefor, a circuit-operating device for said circuit comprising two cooperating members, means connecting one of said members with the timing-mechanism, and means connecting the other member with the timed-supervisory-mechanism, said members being normally disengaged and adapted to maintain their normal relative positions while the timing-mechanism and timed-supervisory-mechanism run in synchronism but to engage each other when they run out of synchronism, substantially as described.

9. The combination of a timing-mechanism and a timed-supervisory-mechanism, a code-signal-transmitting-device, a circuit operated by it, and a signal-receiving instrument controlled by said circuit, and means operated by the timing-mechanism and

timed-supervisory-mechanism, acting conjointly, to prevent the operation of said signal-transmitting device and operated by either, exclusively of the other, to operate  
5 said signal-transmitting-device, substantially as described.

10 10. The combination of a timing-mechanism and a timed-supervisory-mechanism, a code signal-transmitting-device, a circuit operated by it and a signal-receiving instrument controlled by said circuit, means operated by the timing-mechanism and timed-supervisory-mechanism, acting conjointly,  
15 when running in synchronism, to prevent the operation of said signal-transmitting-device and operated by either when running out of synchronism, to operate said signal-transmitting-device, substantially as described.

20 11. The combination with a clock having means for recording watchman's signals, of a signaling-device, and automatic means controlled by the clock to operate said signaling-device when said clock stops, substantially  
25 as described.

12. The combination with a clock having means for recording watchman's signals, of a signaling-device, and automatic means controlled by the clock to operate said sig-

naling-device when said clock runs too slow, 30 substantially as described.

13. The combination with a clock having means for recording watchman's signals, of a signaling-device and automatic means controlled by the clock to operate said sig- 35 naling-device when said clock runs too fast, substantially as described.

14. The combination with a clock of a code-signal-transmitting-device, and automatic means controlled by the clock to op- 40 erate said signal-transmitting-device when said clock stops, substantially as described.

15. In a signal-system, the combination with a continuously-running clock for controlling the sending of signals while in op- 45 eration, and other timing-means cooperating with said clock for causing a notification signal to be sent if said clock stops, but which will be prevented from being sent by the continual operation of the clock, sub- 50 stantially as described.

In testimony whereof, I have signed my name to this specification, in the presence of two subscribing witnesses.

FREDERICK W. COLE.

Witnesses:

B. J. NOYES,  
H. B. DAVIS.