

*S. Bateman.*  
*Paddle Wheel.*

*No 109,286.*

*Patented Nov. 15, 1870.*

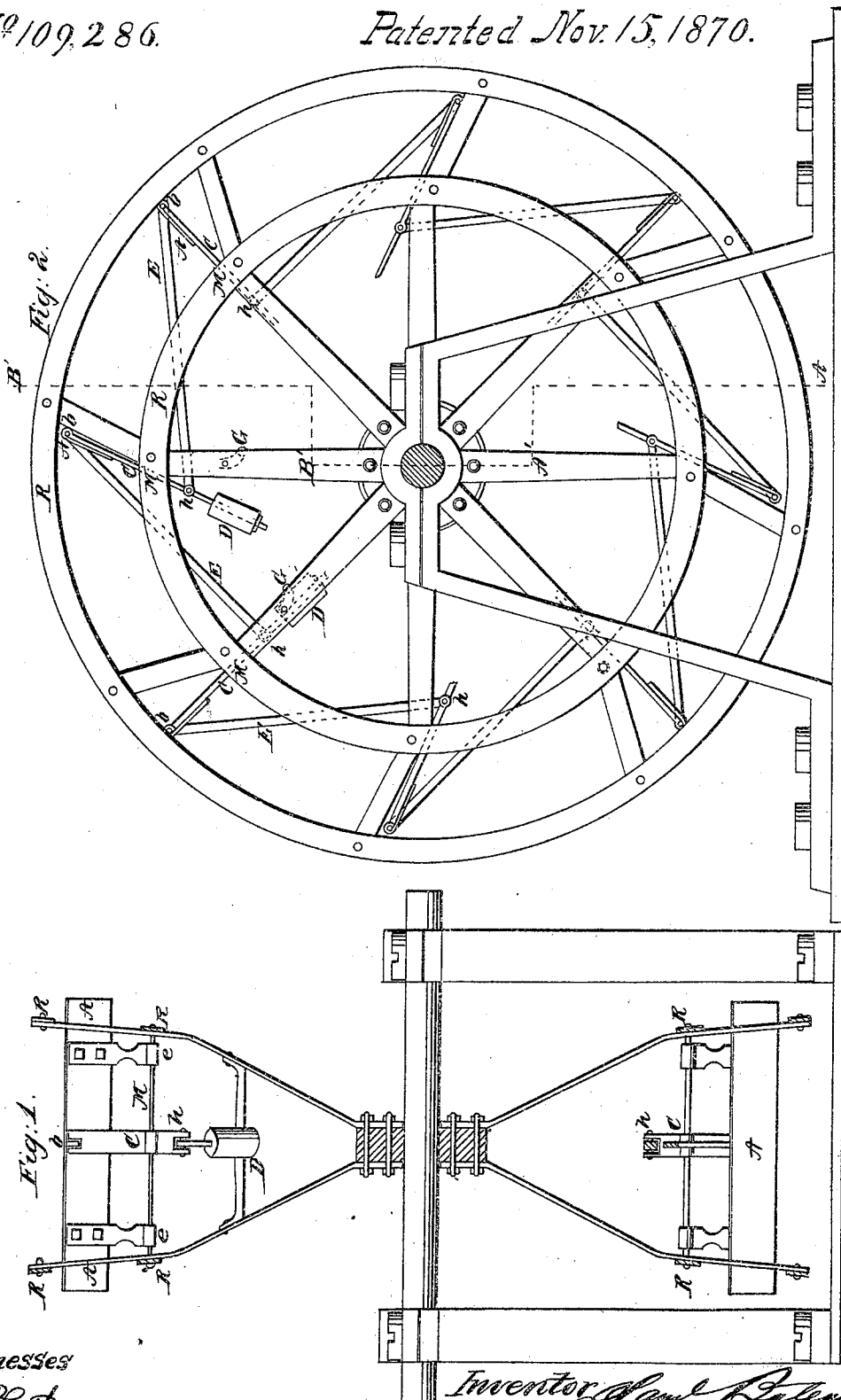

Witnesses  
*[Signature]*  
*[Signature]*

Inventor *Saml Bateman*  
*[Signature]*

# United States Patent Office.

SAMUEL BATEMAN, OF ASNIERE, NEAR PARIS, FRANCE.

Letters Patent No. 109,286, dated November 15, 1870.

## IMPROVEMENT IN PADDLE-WHEELS.

The Schedule referred to in these Letters Patent and making part of the same.

To all to whom these presents shall come:

Be it known that I, SAMUEL BATEMAN, of Asniere, near Paris, in the Empire of France, manufacturer, have invented certain Improvements in Paddle-Wheels; and that the following is a full, clear, and exact description of the principle or character which distinguishes it from all other things before known, and of the usual manner of making, modifying, and using the same.

My invention consists in an improved mode of constructing paddle-wheels, by which the whole of their working power is made available.

To make the invention better understood I will proceed to describe it by reference to the accompanying drawing, in which—

Figure 1 is a section on the line A' B' a' b' of Figure 2, which is a side elevation of a paddle-wheel constructed according to my improvements.

The paddle, A A, properly so called, consists of a sheet or plate of metal or wood, jointed at e e to a shaft, M, the ends of which are fixed in a suitable manner to the frame-work of the wheel R.

Each paddle is provided, at the inner side of the wheel, with an extension piece, C, having at its extremity a buffer, D, and, at the outer side, each paddle is formed with a joint, b, united by a connecting-rod, E, to another joint, h, placed on the extension piece C of the next paddle.

All the paddles are thus united one to another, and the length of the rods is so regulated that one paddle is forced to incline, in turning, on the shaft M.

This paddle acts on the two connecting-rods E, to which it is jointed at b and h in such a manner as to draw into a radial position the paddle which precedes it and that which follows it.

To insure greater firmness to the paddle when it is drawn by the action of the water into this radial position, the buffer D, made of washers of India rubber or other elastic material, strikes against an abutment, G, fixed to the frame-work of the wheel by means of

two crank-pins, and by this means the paddle becomes fixed.

The action of a wheel thus constructed and set in motion in the water is as follows:

The paddle, entering the water in its radial position, will incline under the resistance of the water, and will take an oblique direction, the two paddles next it being brought back to their radial position. In continuing its movement the paddle meets with less resistance, and recovers its radial position from the action of the movement of the preceding paddle, which becomes inclined as it passes through the water, and the same action takes place for all the paddles.

This arrangement, which causes the paddles to yield to the resistance of the water, economizes the motive power, enabling it to give greater speed with the same power and the same number of turns, or of employing less power when it is not required to increase the speed of the vessel. The shock is also less, and the quantity of water thrown up is diminished, thus giving a more useful effect to the motive power.

I do not confine myself to the number of paddles or to their angle of inclination, as their number and angle of inclination may be varied, according to the application or speed of the paddle-wheels.

Having now described my said invention,

What I claim is—

The oscillating paddle A, furnished with an extension piece, C, and an elastic buffer, D, attached thereto, in combination with the connecting-rod E and the abutment G, arranged and operating as herein described.

In testimony whereof, I, the said SAMUEL BATEMAN, have hereto set my hand and affixed my seal, this thirteenth day of August, one thousand eight hundred and sixty-nine.

SAML. BATEMAN. [L. s.]

Witnesses:

JAMES S. BROWN,  
F. OLCOTT.