



(72) GAUTHIER, Alain, FR

(72) BARTHOMEUF, Jean-Paul, FR

(71) SOCIETE DE PROSPECTION ET D'INVENTIONS TECHNIQUES  
SPIT, FR

(51) Int.Cl.<sup>6</sup> F16B 13/06

(30) 1998/03/16 (98 03176) FR

(54) **BOULON D'ANCRAGE AVEC NOYAU D'EXPANSION**

(54) **ANCHOR BOLT WITH AN EXPANSION CORE**

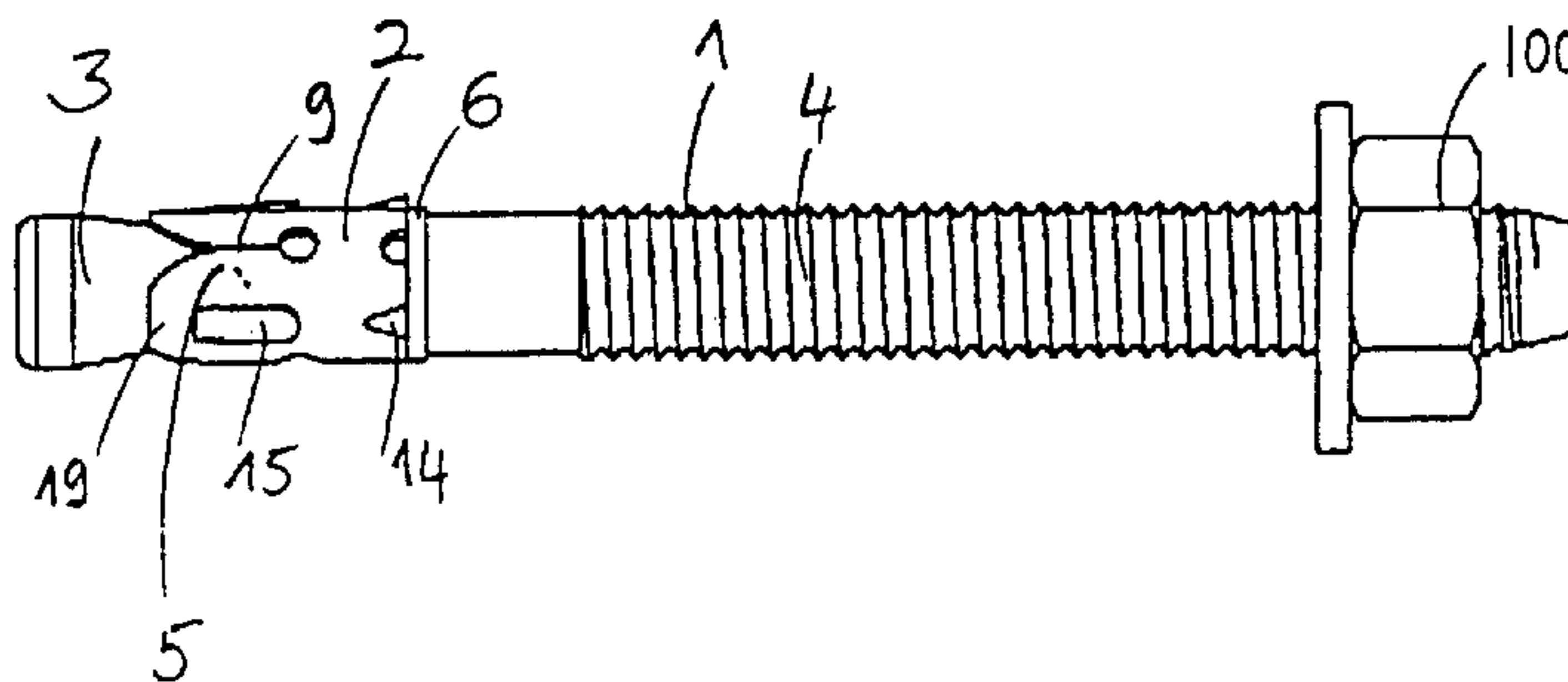

(57) The anchor bolt comprises a fixing rod (1), an expandable sleeve (2) and an expansion core (3) integral in translation with the fixing rod (1), intended to expand the sleeve (2). The sleeve (2) makes a plurality of slots (9, 9') widening towards the free end of the sleeve (2), thereby forming a plurality of expansion teeth (18-20) cooperating with the expansion core (3). The inner wall of the edge of the teeth (18-20) is blunt.

**ABSTRACT**

5

**ANCHOR BOLT WITH AN EXPANSION CORE**

The anchor bolt comprises a fixing rod (1), an expandable sleeve (2) and an expansion core (3) integral in translation with the fixing rod (1), intended to expand the sleeve (2). The sleeve (2) makes a plurality of slots (9, 9') widening towards the free end of the sleeve (2), thereby forming a plurality of expansion teeth (18-20) cooperating with the expansion core (3). The inner wall of the edge of the teeth (18-20) is blunt.

## ANCHOR BOLT WITH AN EXPANSION CORE

5 The invention relates to an anchor bolt with an expansion core intended to be introduced into and anchored in a material, e.g. a wall, in order to fix an article of some kind thereto.

10 The invention relates more particularly to an anchor bolt comprising a fixing rod, an expandable sleeve and an expansion core integral in translation with the fixing rod, intended to expand the sleeve, the sleeve making at least one slot widening towards a free end of the sleeve, thereby forming at least one expansion tooth cooperating with the core. The expansion tooth is designed to decrease the pressures being exerted on the sleeve during expansion and thus making easier the expansion.

15 With bolts of this type, there is a not inconsiderable risk that the inner edge of the tooth or of the teeth of the expandable sleeve will not be anchored in the expansion core, thereby damaging it and impeding the translation thereof towards the exterior of the locating hole for the bolt. The operator then has to use great force in order to free the expansion core and anchor the bolt.

The invention aims to obviate this disadvantage.

25 To this end, the invention relates to a bolt of the type defined hereinabove, characterised in that the inner wall of the edge of the expansion tooth is blunt.

The tooth is thus made less hurting.

30 The thickness of the tooth advantageously decreases towards the said free end of the sleeve.

The expansion of the sleeve is consequently made easier.

35 The sleeve more advantageously comprises one anti-rotation stamped boss.

40 Thus, the contact surface between the sleeve and the expansion core is less important. Consequently, the friction between the sleeve and the expansion core is decreased, which makes easier the relative movement of the core and the sleeve.

The invention will be more readily understood with the aid of the following description of one particular embodiment of the anchor bolt of the invention with reference to the accompanying drawings, in which:

5

Figure 1 is a disagrammatic side view of the anchor bolt according to the particular embodiment of the invention;

10

Figure 2 is a perspective view of an expandable sleeve of the bolt of Figure 1, and

Figure 3 is another perspective view of the expandable sleeve of Figure 2.

15

The anchor bolt comprises a fixing rod 1, an expandable sleeve 2 and an expansion core 3, in this case in the form of a truncated cone.

20

The fixing rod 1 comprises a fixing portion 4 provided with an external thread and an expansion portion 5 adjacent to the fixing portion 4 along the axis of the rod 1. The expansion portion 5 is integral at its end opposite the end at which it is connected to the fixing portion 4 with the expansion cone 3 which widens out towards the free end of the rod 1. The rod 1 is therefore integral in translation with the expansion core 3. A shoulder 6, constituting a stop for the sleeve 2, is designed between the fixing portion 4 and the expansion portion 5.

25

The expandable sleeve 2 is mounted around the expansion portion 5 and is held in position between the expansion cone 3 and the shoulder 6.

30

The sleeve 2, which is open (i.e. not completely closed, rolled up), in this case comprises a non-slotted part 7 and an anchoring part 8 adjacent to the non-slotted part 7 along the axis of the sleeve 2.

35

In this case, the anchoring part 8 forms two anchoring slots 9, 9' of substantially zero width close to the non-slotted part 7 and widening towards the free end of the anchoring part 8 of the sleeve 2, thereby forming three expansion teeth 18-20, cooperating with the expansion cone 3. The widening of the slots 9, 9' allows to decrease the pressures supported by the anchoring part 8 of the sleeve 2, during expansion. The expansion teeth 18-20 are intended to make easier the expansion of the sleeve 2.

40

The anchoring part 8 comprises three anti-rotation bosses 13, 15, 17, intended to prevent rotation of the bolt. The bosses 13, 15, 17 are generally rectangular and formed by stamping the wall of the sleeve 2.

5

The non-slotted part 7 also comprises three anti-rotation stamped bosses 12, 14, 16, located nearby the edge of free end of the non-slotted part 7.

10 The inner wall 10 of the edge of the teeth 18-20 of the expandable sleeve 2 is blunt. In other words, the perimeter of teeth 18-20 is rounded and thus made less hurting, on the inner side of the sleeve 2. Consequently, the sleeve 2 does not damage the expansion core 3. Furthermore, the thickness of the wall 11 of the expansion teeth 18-20 decreases towards the free end of the anchoring part 8, the inner surface of the wall 11 of the teeth 18-20 widening  
15 out continuously towards the free end.

In order to anchor the bolt in a support, a hole into which the anchor bolt is introduced is drilled in the support in advance. A nut 100 is then screwed on to the fixing portion 4 of the rod 1. The bosses 12-17 anchor in the wall of  
20 the hole and thus prevent rotation of the bolt in a known manner, such that the action of screwing the nut 100 guides the fixing rod 1 in translation towards the exterior of the hole and the expansion cone 3 expands the sleeve 2, which is anchored in the support.

25

30

35

40

WHAT IS CLAIMED IS:

5 1. Anchor bolt comprising a fixing rod (1), an expandable sleeve (2) and an  
expansion core (3) integral in translation with the fixing rod (1), intended to  
expand the sleeve (2), the sleeve (2) making at least one slot (9, 9') widening  
towards the free end of the sleeve (2), thereby forming at least one  
expansion tooth (18-20) cooperating with the expansion core (3),  
10 characterised in that the inner wall of the edge of the tooth (18-20) is blunt.

2- Bolt according to claim 1, in which the thickness of the tooth (18-20)  
decreases towards the said free end of the sleeve (2).

15 3- Bolt according to one of claims 1 and 2, in which the sleeve (2)  
comprises at least one anti-rotation stamped boss (13, 15, 17).

4- Bolt according to claim 3, in which the anti-rotation boss (13, 15, 17) is  
generally rectangular.

20

25

30

35

40

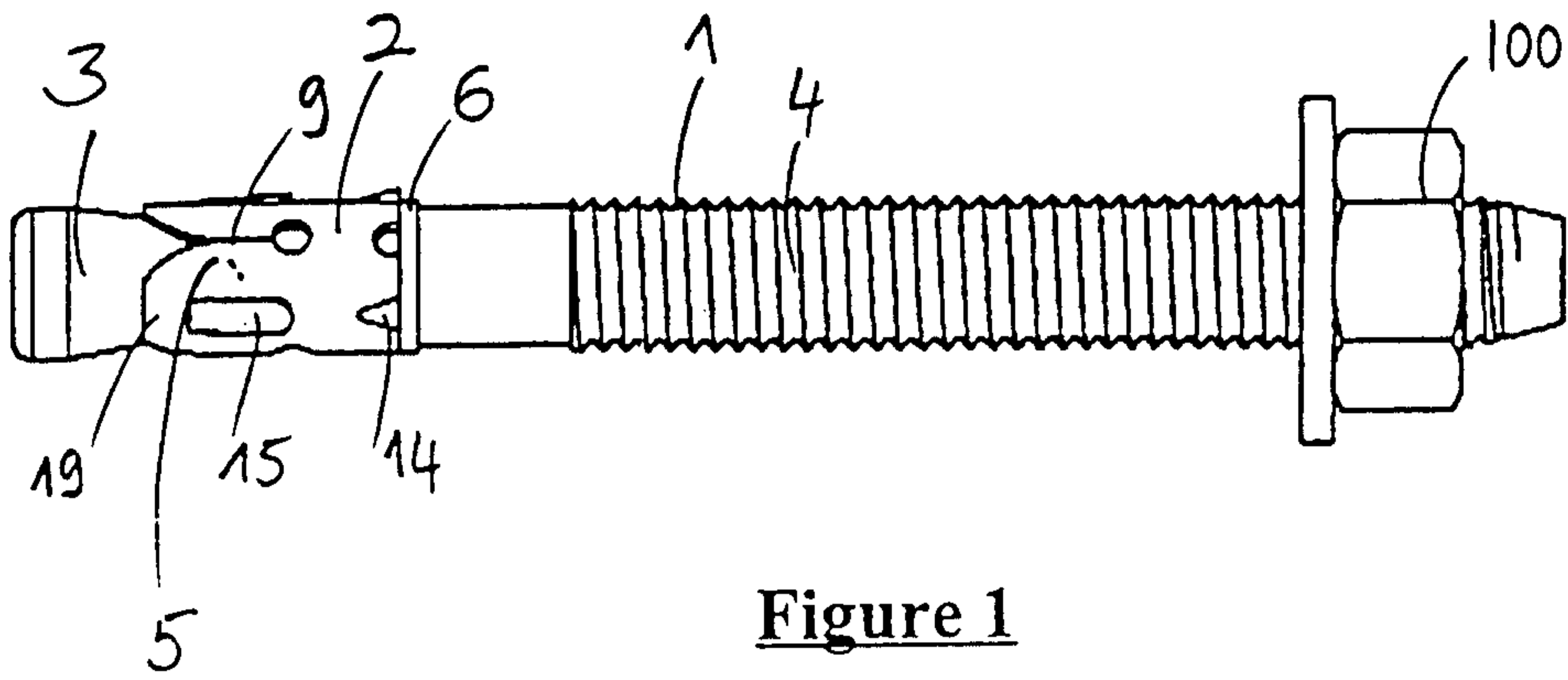

**Figure 1**

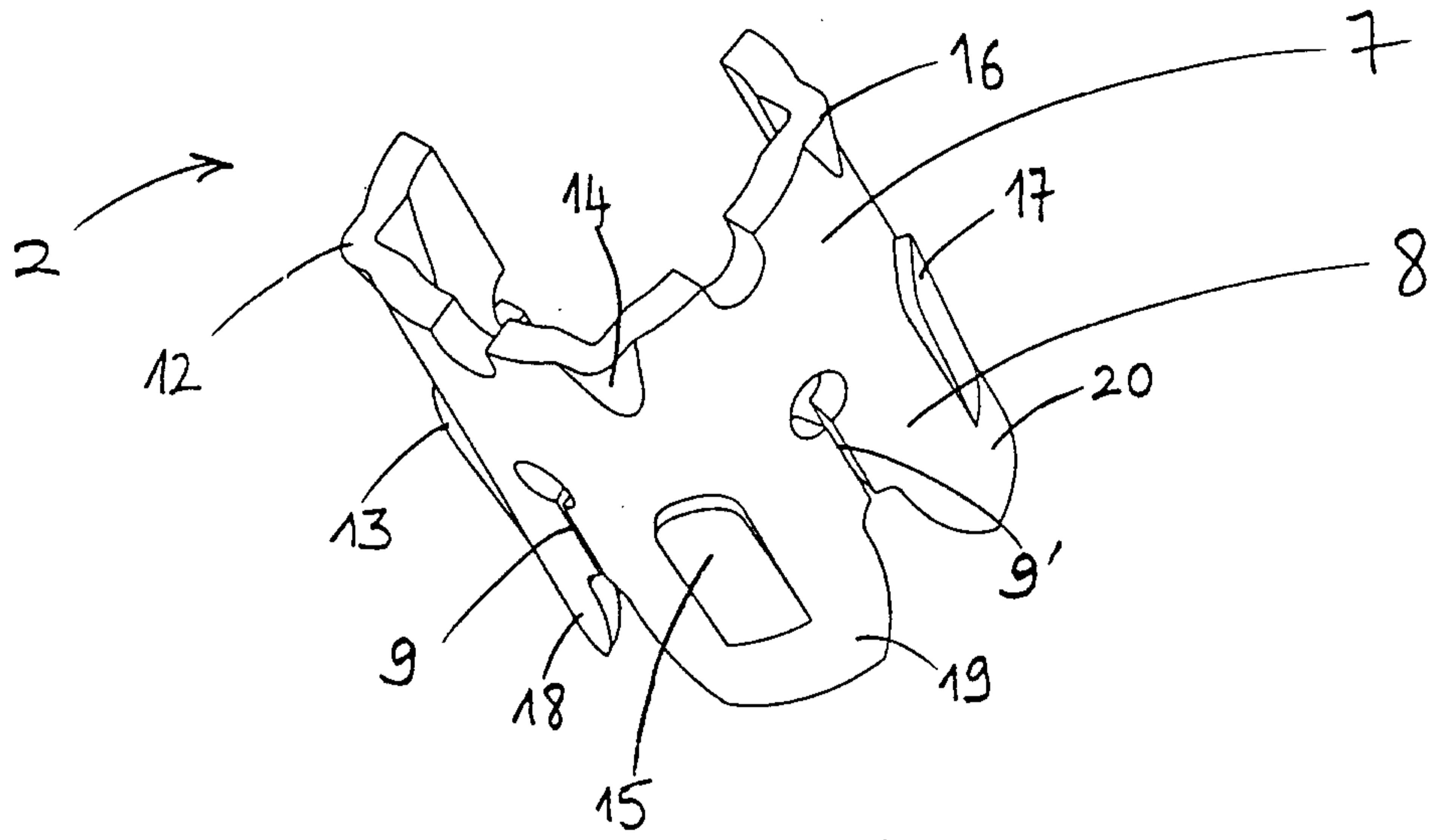

**Figure 2**

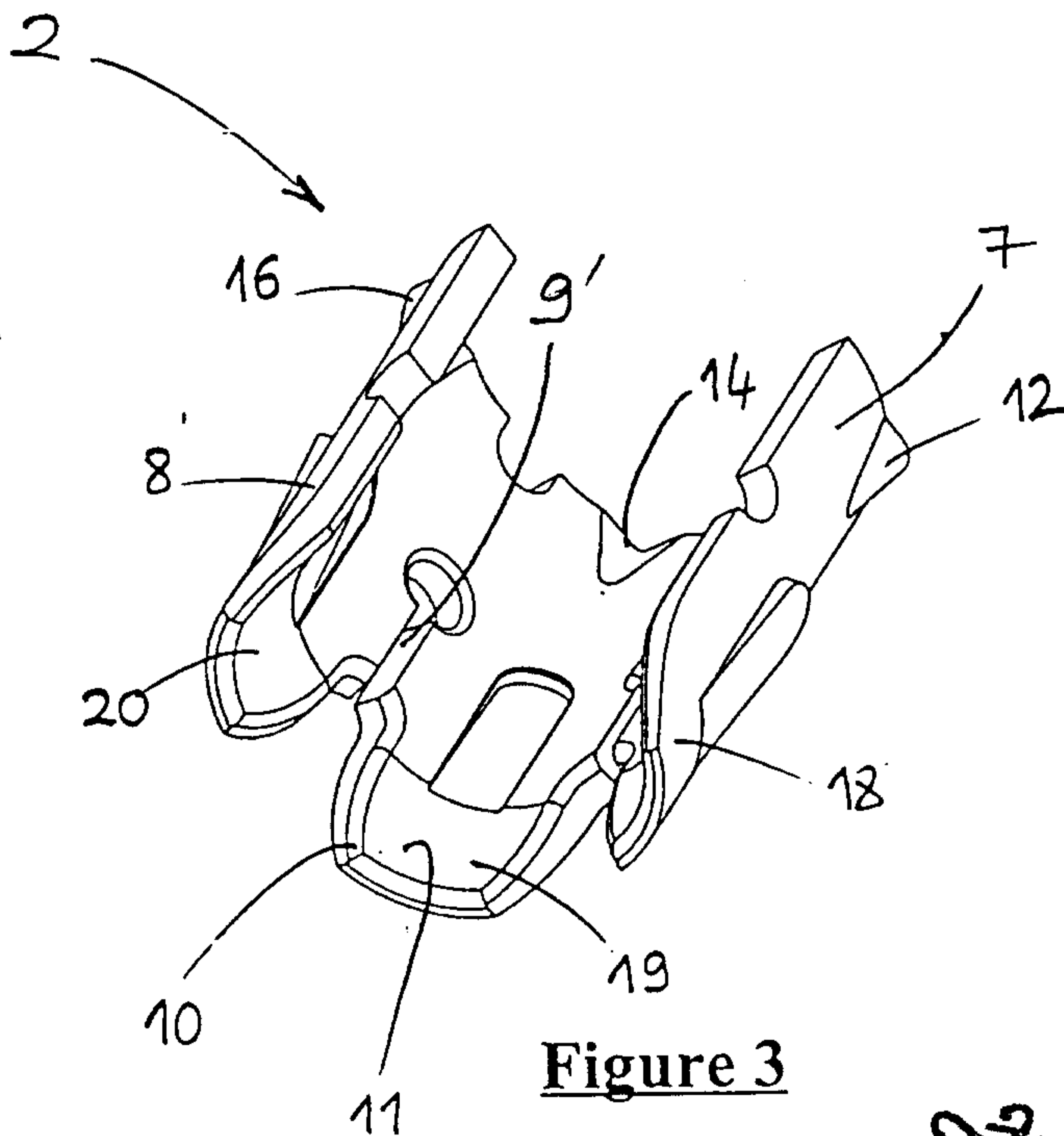

**Figure 3**

*Sulayman & Associates*  
PATENT AGENTS