



- (51) **International Patent Classification:**
H01Q 21/24 (2006.01)
- (21) **International Application Number:**
PCT/CN2020/085684
- (22) **International Filing Date:**
20 April 2020 (20.04.2020)
- (25) **Filing Language:** English
- (26) **Publication Language:** English
- (30) **Priority Data:**
16/388,274 18 April 2019 (18.04.2019) US
- (71) **Applicant: HUAWEI TECHNOLOGIES CO., LTD.**
[CN/CN]; Huawei Administration Building, Bantian, Longgang District, Shenzhen, Guangdong 518129 (CN).
- (72) **Inventors: BOUTAYEB, Halim;** 56 Bannock Cres, Kanata, Ontario K2K 2P9 (CA). **HYJAZIE, Fayez;** 171 Clar-

idge Drive, Ottawa, Ontario K2J 5V8 (CA). **CHEN, Teyan;** Huawei Administration Building, Bantian, Longgang District, Shenzhen, Guangdong 518129 (CN). **WU, Tao;** Huawei Administration Building, Bantian, Longgang District, Shenzhen, Guangdong 518129 (CN). **MILYAVSKY, Matthew;** 38 Craig Henry Drive, Ottawa, Ontario K2G 3S6 (CA).

(81) **Designated States** (unless otherwise indicated, for every kind of national protection available): AE, AG, AL, AM, AO, AT, AU, AZ, BA, BB, BG, BH, BN, BR, BW, BY, BZ, CA, CH, CL, CN, CO, CR, CU, CZ, DE, DJ, DK, DM, DO, DZ, EC, EE, EG, ES, FI, GB, GD, GE, GH, GM, GT, HN, HR, HU, ID, IL, IN, IR, IS, JO, JP, KE, KG, KH, KN, KP, KR, KW, KZ, LA, LC, LK, LR, LS, LU, LY, MA, MD, ME, MG, MK, MN, MW, MX, MY, MZ, NA, NG, NI, NO, NZ, OM, PA, PE, PG, PH, PL, PT, QA, RO, RS, RU, RW, SA, SC, SD, SE, SG, SK, SL, ST, SV, SY, TH, TJ, TM, TN, TR, TT, TZ, UA, UG, US, UZ, VC, VN, WS, ZA, ZM, ZW.

(54) **Title:** ANTENNA STRUCTURE AND METHOD FOR MANUFACTURING THE SAME

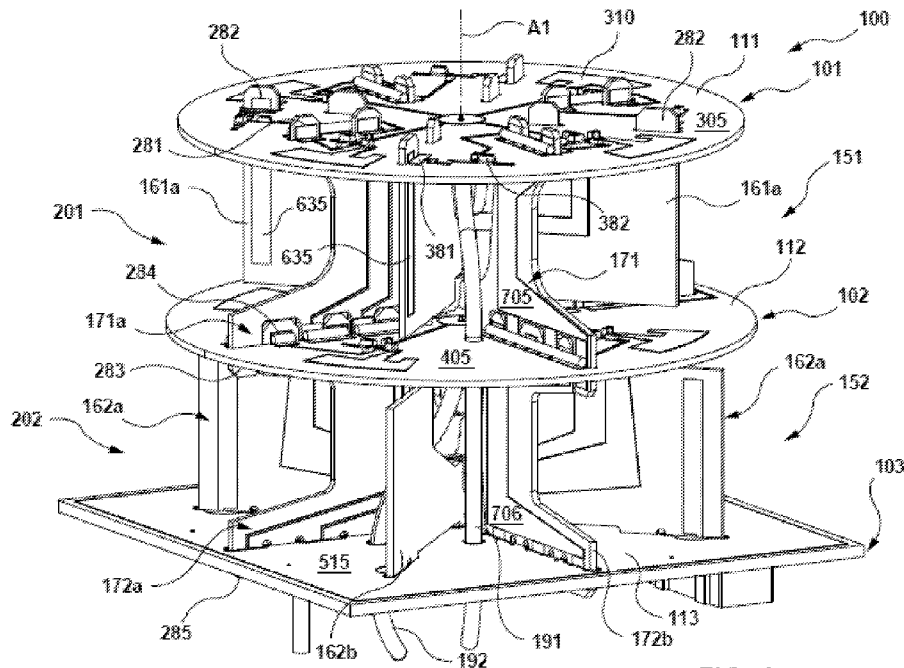

FIG. 1

(57) **Abstract:** The disclosed structures and methods are directed to antenna systems configured to transmit and receive a wireless signal in and from different directions. An antenna structure comprises a pair of horizontal-polarization (HP) antenna units forming a first parallel-plate waveguide. One of the HP antenna units and a base unit form a second parallel-plate waveguide. The antenna further comprises a pair of vertical-polarization (VP) antenna units each located in one of the first and second parallel-plate waveguides. Each HP antenna unit comprises inverted F antennas (IFAs) configured to radiate a radio-frequency (RF) waves that are horizontally polarized. Each VP antenna unit comprises VP excitation elements configured to radiate the RF waves that are vertically polarized. A method for manufacturing of the antenna structure is also disclosed.



(84) Designated States (*unless otherwise indicated, for every kind of regional protection available*): ARIPO (BW, GH, GM, KE, LR, LS, MW, MZ, NA, RW, SD, SL, ST, SZ, TZ, UG, ZM, ZW), Eurasian (AM, AZ, BY, KG, KZ, RU, TJ, TM), European (AL, AT, BE, BG, CH, CY, CZ, DE, DK, EE, ES, FI, FR, GB, GR, HR, HU, IE, IS, IT, LT, LU, LV, MC, MK, MT, NL, NO, PL, PT, RO, RS, SE, SI, SK, SM, TR), OAPI (BF, BJ, CF, CG, CI, CM, GA, GN, GQ, GW, KM, ML, MR, NE, SN, TD, TG).

Published:

— *with international search report (Art. 21(3))*

ANTENNA STRUCTURE AND METHOD FOR MANUFACTURING THE SAME

5 **CROSS-REFERENCE TO RELATED APPLICATIONS**

[1] This application claims the benefit of priority to US Patent Application Serial No 16/388,274 filed April 18, 2019 and entitled “Antenna Structure and Method for Manufacturing the Same” the contents of which are incorporated herein by reference.

10 **FIELD OF THE INVENTION**

[2] The present invention generally relates to the field of wireless communications and, in particular, to antenna systems configured to transmit and receive a wireless signal in and from different directions.

15 **BACKGROUND**

[3] Access Points (APs) for use with Wireless Local Area Networks (WLANs) systems incorporate Multiple Inputs-Multiple Outputs (MIMO) antennae. MIMO antenna are employed to enhance channel capacity and increase the number of wireless streams, in accordance with market service demands.

20 [4] Each additional wireless stream may be associated with one additional antenna element. Thus, APs will need to incorporate more antenna elements to service the increased number of wireless streams in various frequency ranges while also fitting in the same or even smaller physical space and demonstrating improved performance.

SUMMARY

25 [5] An object of the present disclosure is to provide an antenna for transmission of a radio-frequency (RF) wave configured to transmit and receive a wireless signal in and from different directions. The antenna as described herein is configured to operate in various frequency ranges.

[6] In accordance with this objective, an aspect of the present disclosure provides an
30 antenna structure for transmission of a radio-frequency (RF) wave, the antenna structure comprising: a base unit; a first horizontal-polarization (HP) antenna unit having a plurality of first inverted F antennas (IFAs) configured to radiate the RF wave in a horizontal

polarization; a second HP antenna unit having a plurality of second IFAs configured to radiate the RF wave in the horizontal polarization, positioned so that the first HP antenna unit and the second HP antenna unit are spaced apart from each other and form a first parallel-plate waveguide, and so that the second HP antenna unit and the base unit are spaced
5 apart from each other and form a second parallel-plate waveguide. The antenna also comprises a first vertical-polarization (VP) antenna unit located in the first parallel-plate waveguide and having a plurality of first VP excitation elements configured to radiate the RF wave in a vertical polarization; and a second VP antenna unit located in the second parallel-plate waveguide and having a plurality of second VP excitation elements configured to
10 radiate the RF wave in the vertical polarization.

[7] In at least one embodiment, the antenna further comprises first HP switchable elements, each connected to one of the first IFAs, the first HP switchable elements being configured to control a radiation pattern of the first HP antenna unit. In at least one embodiment, the antenna further comprises second HP switchable elements, each connected
15 to one of the second IFAs, the second HP switchable elements being configured to control the radiation pattern of the second HP antenna unit.

[8] In at least one embodiment, the first VP antenna unit and the second VP antenna unit further comprise parasitic elements for controlling a radiation pattern of RF wave by the first VP antenna unit and the second VP antenna unit. The parasitic elements may be operated
20 by VP switchable elements located in at least one of the first HP antenna unit and the second HP antenna unit.

[9] In at least one embodiment, the first VP excitation elements form a first VP exciting probe, and the second VP excitation elements form a second VP exciting electric probe.

[10] In at least one embodiment, the antenna further comprises a pair of second feeding supports and a pair of first feeding supports configured to provide electrical current to second HP switchable elements, first HP switchable elements and first VP switchable elements. The pair of second feeding supports may be configured to provide direct current to second VP switchable elements.

[11] In at least one embodiment, the first HP antenna unit may comprise a first HP substrate having apertures for receiving protruding portions of first VP substrates of the first VP antenna unit. The received protruding portions of the first VP substrates may be configured to electrically connect first parasitic elements located on the first VP substrates and first VP switchable elements, the first VP switchable elements being located on the first HP substrate and configured to operate the first parasitic elements for controlling a radiation pattern of the second VP antenna unit.

[12] In at least one embodiment, the first HP substrate may comprise aperture for receiving protruding portions of first feeding supports configured to electrically connect the first VP switchable elements to first DC lines located on surfaces of the first feeding supports. The second HP antenna unit may comprise a second HP substrate having apertures for receiving other protruding portions of the first VP substrates of the first VP antenna unit.

[13] In at least one embodiment, the base unit may comprise second VP switchable elements configured to operate second parasitic elements for controlling a radiation pattern of the second VP antenna unit, the second parasitic elements being electrically connected to the second VP switchable elements.

[14] In at least one embodiment, the second HP antenna unit further comprises apertures configured to receive protruding portions of second feeding supports comprising portions of second DC lines and second feeding ground layers; DC conducting pads located on the second HP antenna unit and configured to electrically connect first DC lines located on first feeding supports to the second DC lines located on the second feeding supports; and ground conducting pads located on the second HP antenna unit and configured to electrically connect first feeding ground layers located on first feeding supports to the second feeding ground layers located on the second feeding supports.

[15] In at least one embodiment, each of the first HP antenna unit, the second HP antenna unit, the first VP antenna unit, the second VP antenna unit, and base unit may comprise at least one substrate made of a printed circuit board (PCB).

[16] In at least one embodiment, the first HP antenna unit and the second VP antenna unit are configured to operate in a first frequency range; and the second HP antenna unit and the first VP antenna unit are configured to operate in a second frequency range. The first

frequency range may overlap with the second frequency range. In at least one embodiment, a difference between the first frequency range and the second frequency range is more than 1 gigahertz (GHz). The first frequency range may comprise frequencies that are lower than frequencies of the second frequency range. The first frequency range may comprise 5 GHz and the second frequency range comprises 6 GHz.

[17] In at least one embodiment, the antenna structure is one of a plurality of antenna structures forming an antenna array, and the antenna array further comprises a plurality of third antenna units, each third antenna unit having a monopole configured to radiate RF wave being vertically polarized in a third frequency range and a third IFA configured to radiate the RF wave being horizontally polarized. In at least one embodiment, the third frequency range comprises 2.5 GHz.

[18] In accordance with other aspects of the present disclosure, there is provided a method for manufacturing of an antenna structure for transmission of a radio-frequency (RF) wave. The method comprises attaching inverted F antennas (IFAs) and switchable elements to a first horizontal-polarization (HP) substrate of a first HP antenna unit and a second HP substrate of a second HP antenna unit; attaching first and second vertical-polarization (VP) excitation elements and first and second parasitic elements to first VP substrates and second VP substrates; attaching a first HP RF cable to the first HP antenna unit, attaching a first VP RF cable to one of first VP substrates, and attaching a second HP RF cable to a second HP antenna unit.

[19] In at least one embodiment, the method comprises also coupling the first VP substrates to the first HP antenna unit and electrically connecting the first parasitic elements located on the first VP substrates to corresponding first RF connecting pads located on the first HP substrate; attaching second feeding supports and second VP substrates to a base unit; coupling the second HP antenna unit to first feeding supports and the second feeding supports and electrically connecting first and second DC lines and first and second feeding ground layers located on the first feeding supports and on the second feeding supports to corresponding second DC conducting pads and second ground pads located on the second HP substrate; and coupling the first HP unit to the first feeding supports and electrically connecting the first DC lines and the first feeding ground layers located on the first feeding supports to corresponding first DC conducting pads and first ground pads located on the first HP substrate.

[20] In at least one embodiment, attaching the first VP RF cable to the first VP antenna unit further comprises attaching the first VP RF cable to a VP feeding substrate and placing the VP feeding substrate approximately in parallel to the first HP substrate and the second HP substrate.

5 [21] Implementations of the present disclosure each have at least one of the above-mentioned object or aspects, but do not necessarily have all of them. It should be understood that some aspects of the present disclosure that have resulted from attempting to attain the above-mentioned object may not satisfy this object and may satisfy other objects not specifically recited herein.

10 [22] Additional and alternative features, aspects and advantages of implementations of the present disclosure will become apparent from the following description, the accompanying drawings and the appended claims.

BRIEF DESCRIPTION OF THE FIGURES

15 [23] Further features and advantages of the present disclosure will become apparent from the following detailed description, taken in combination with the appended drawings, in which:

[24] FIG. 1 depicts a perspective view of an antenna structure, in accordance with various embodiments of the present disclosure;

20 [25] FIG. 2 depicts an alternative perspective view of the antenna structure of FIG. 1;

[26] FIG. 3A depicts a top view of a first horizontal-polarization (HP) unit of the antenna structure, in accordance with various embodiments of the present disclosure;

[27] FIG. 3B depicts an underside view of first HP unit, in accordance with various embodiments of the present disclosure;

25 [28] FIG. 4A depicts a perspective top view of a second HP unit, in accordance with various embodiments of the present disclosure;

[29] FIG. 4B depicts an underside view of the second HP unit, in accordance with various embodiments of the present disclosure;

[30] FIG. 5 depicts a perspective underside view of the antenna structure of FIG. 1, in accordance with various embodiments of the present disclosure;

[31] FIG. 6A depicts a front view of a first vertical-polarization (VP) unit and a second VP unit, mounted on first and second HP units of the antenna structure of FIG. 1, in accordance with various embodiments of the present disclosure;

[32] FIG. 6B depicts a back view of the first VP unit and the second VP unit, mounted on first and second HP units of the antenna structure of FIG. 1, in accordance with various embodiments of the present disclosure;

[33] FIG. 7A depicts a front view of feeding supports mounted on the first and second HP units of the antenna structure of FIG. 1, in accordance with at least one non-limiting embodiment of the present disclosure;

[34] FIG. 7B depicts a back view of feeding supports mounted on the first and second HP units of the antenna structure of FIG. 1, in accordance with at least one non-limiting embodiment of the present disclosure;

[35] FIG. 8A depicts azimuth radiation patterns of operation of the antenna structure of FIG. 1 when the second VP unit is in an omnidirectional operation mode and in a directional operation mode, in accordance with at least one non-limiting embodiment of the disclosure;

[36] FIG. 8B depicts reflection coefficient (*i.e.*, S_{11} -parameter) of the antenna structure of FIG. 1, when the first VP unit is in the omnidirectional operation mode and in the directional operation mode of FIG. 8, in accordance with at least one non-limiting embodiment of the disclosure;

[37] FIG. 9A depicts azimuth radiation patterns of the second VP unit of the antenna structure of FIG. 1 in a directional operation mode with one, two, and three second VP switchable elements being in "ON" mode, in accordance with at least one non-limiting embodiment of the present disclosure;

[38] FIG. 9B depicts return loss for the second VP unit of the antenna structure of FIG. 1 in the directional operation mode with one, two, and three VP switchable elements being in "ON" mode, in accordance with at least one non-limiting embodiment of the present disclosure;

[39] FIG. 10 depicts an antenna array, in accordance with at least one non-limiting embodiment of the present disclosure;

[40] FIG. 11 depicts return loss, *i.e.* S_{11} -parameter, for the first VP unit operating in a 6 GHz band and for the second VP unit operating in a 5 GHz band, and a coupling coefficient, *i.e.* S_{21} -parameter, between the first VP unit and the second VP unit, as a function of frequency of the antenna structure of FIG. 1, in accordance with at least one non-limiting embodiment of the present disclosure;

[41] FIG. 12A depicts azimuth radiation patterns of the antenna structure of FIG. 1 when the second HP unit operates in a directional operation mode and in an omnidirectional operation mode, in accordance with at least one non-limiting embodiment of the present disclosure;

[42] FIG. 12B depicts azimuth radiation patterns of the antenna structure of FIG. 1 when the first HP unit operates in the 6 GHz band in the directional mode and omnidirectional mode, in accordance with at least one non-limiting embodiment of the present disclosure;

[43] FIG. 12C depicts return loss, *i.e.* S_{11} -parameter, as a function of frequency of the antenna structure of FIG. 1 when the first HP unit operates in the 6 GHz band and the second HP unit operates in the 5 GHz band, in accordance with at least one non-limiting embodiment of the present disclosure; and

[44] FIG. 13 depicts a flow chart illustrating a method for manufacturing of the antenna of FIG. 1, in accordance with at least one non-limiting embodiment of the present disclosure.

[45] It is to be understood that throughout the appended drawings and corresponding descriptions, like features are identified by like reference characters. Furthermore, it is also to be understood that the drawings and ensuing descriptions are intended for illustrative purposes only and that such disclosures do not provide a limitation on the scope of the claims.

DETAILED DESCRIPTION

[46] The instant disclosure is directed to address at least some of the deficiencies of the current antenna implementations. In particular, the instant disclosure describes an antenna structure configured to receive and radiate electromagnetic (EM) waves in at least two frequency bands and in two different polarizations. The EM waves that are propagated by and received by the disclosed antenna structure may operate within a radio frequency (RF) range (*i.e.*, RF wave). In some other embodiments, the EM waves may operate within a microwave range (e.g., about 1 GHz to about 30 GHz).

[47] The antenna structure and associated technology described herein may be embodied in a variety of different electronic devices (EDs) including, for example, base stations (BSs), user equipment (UE), wireless routers, wireless access points, *etc.*

[48] As used herein, the term “about” or “approximately” refers to a $\pm 10\%$ variation from the nominal value. It is to be understood that such a variation is always included in a given value provided herein, whether or not it is specifically referred to.

[49] As referred to herein, the term “guided wavelength” refers to a guided wavelength of the propagating EM wave that provides a near transverse electromagnetic mode (TEM) in a microstrip line (*i.e.*, quasi TEM). In addition, as referred to herein, the term “via” refers to an electrical connection providing electrical connectivity between the physical layers of an electronic circuit. As referred to herein, the term “RF cable” refers to an RF source coaxial cable.

[50] Unless defined otherwise, all technical and scientific terms used herein have the same meaning as commonly understood by one of ordinary skill in the art to which this invention belongs.

[51] The antenna structure as described herein, in various embodiments, may be formed from several multi-substrate printed circuit boards (PCBs). The antenna structure may also comprise PCB features such as etched conductive substrates, vias, and other elements. Such a PCB implementation may be suitably compact for inclusion in various wireless communication equipment, including basestations, access points and mobile devices, well as being cost-effective for volume production.

[52] Referring to the drawings, FIGs. 1, 2 depict perspective views of antenna structure **100**, in accordance with at least one non-limiting embodiment. As shown, antenna structure

100 comprises a first horizontal-polarization (HP) antenna unit **101** (also referred to herein as an “upper HP unit” or “first HP unit”), a second HP antenna unit **102** (also referred to herein as an “lower HP unit” or “second HP unit”), a first vertical-polarization (VP) antenna unit **151** (also referred to herein as an “upper VP unit” or “first VP unit”), and a second VP unit **152** (also referred to herein as a “lower VP unit” or “second VP unit”). Antenna structure **100** also comprises a base unit **103** and a pair of first feeding supports **171** as well as a pair of second feeding supports **172**.

[53] Each of the first and second HP units **101**, **102** is configured to radiate and receive horizontally polarized RF waves. Each of the first and second VP units **151**, **152** is configured to radiate and receive vertically polarized RF waves. The first and second HP units **101**, **102** and first and second VP units **151**, **152** are collocated, as described herein, in order to reduce the size of antenna structure **100**.

[54] Antenna structure **100** may operate in both, horizontal and vertical polarizations, to accommodate a plurality of wireless data streams (*e.g.*, four data streams). Moreover, the radiation pattern of each wireless data stream may be controlled and modified such that antenna structure **100** operates in an omnidirectional mode as well as various directional modes. The antenna structure **100** may also operate in two different frequency ranges.

[55] FIG. 3A depicts top view of first HP unit **101** of antenna structure **100** and FIG. 3B depicts an underside view of first HP unit **101** of antenna structure **100**, in accordance with various embodiments. In addition, FIGs. 4A, 4B depict a perspective top view and an underside view, respectively, of second HP unit **102** of antenna structure **100**, in accordance with the various embodiments. It should be noted that references to “top”, “underside”, or “bottom” are provided herein for ease of reference to the drawings and are not intended to be limiting.

[56] As depicted in FIG. 3A, the first HP unit **101** comprises a first HP substrate **111** having first HP excitation elements **310** on its top surface **305** and a first ground layer **315** on its underside surface **306**. And, as depicted in FIG. 4A, the second HP unit **102** comprises a second HP substrate **112** having second HP excitation elements **410** on its top surface **405** and a second ground layer **415** on its underside surface **406**.

[57] Returning to FIG. 1, base unit **103** comprises a base substrate **113** and a main ground layer **515** located on a top surface of base unit **103**. Base substrate **113** may be fabricated so that it has a set of apertures defined within it, as will be discussed in more detail below. In operation, ground layers **315**, **415** and **515** of first HP unit **101**, second HP unit **102** and base unit **103** are electrically connected to an electrical ground. These ground layers **315**, **415** and **515** may be made from a metal material, such as copper.

[58] The first HP substrate **111** is positioned substantially parallel to both second HP substrate **112** and base substrate **113**. In other words, first HP substrate **111**, second HP substrate **112**, and base substrate **113** are arranged to be “stacked up” in a parallel manner.

[59] A first radial parallel-plate waveguide **201** is created in the space between substantially parallel ground layers **315** and **415**. A second radial parallel-plate waveguide **202** is created in the space between substantially parallel ground plates **415** and **515**. The first and second parallel-plate waveguides may also be referred to as the first and second waveguides respectively. Moreover, as shown in FIG. 1, the first VP unit **151** is located within first waveguide **201** and second VP unit **152** is located within second waveguide **202**.

[60] Referring to FIG. 3A, first HP unit **101** comprises a plurality of first HP excitation elements **310** (illustrated as **310a**, **310b**, **310c** and **310d**) located in figure HP substrate **111**. In the illustrated embodiment, first HP excitation elements **310** are implemented as inverted-F antennas (IFAs) **310a**, **310b**, **310c**, **310d** (collectively referred to as “first IFAs **310**”). Similarly, as depicted in FIG. 4A, second HP excitation elements **410** are implemented as IFAs **410a**, **410b**, **410c**, **410d** (collectively referred to as “second IFAs **410**”). The second IFAs **410** are located on second HP substrate **112** of second HP unit **102**. In the illustrated embodiment, first HP unit **101** and second HP units each contain four IFAs **310**, **410**.

[61] The first IFAs **310** and second IFAs **410** are configured to radiate and to receive EM waves. In at least one embodiment, IFAs **310**, **410** are printed on first HP substrate **111** and second HP substrate **112**, respectively. Each of the IFAs **310**, **410** is operated and controlled by a corresponding HP switchable element **320**, **420**. The HP switchable elements **320**, **420** may encompass PIN diodes, variable capacitors (varicaps), microelectromechanical systems (MEMS) elements, *etc.*

[62] As respectively depicted in FIGs. **3B**, **4B**, each HP switchable element **320**, **420** is coupled to a ground via **325**, **425**. Ground vias **325**, **425** are coupled to a first ground layer **315**, **415** located on the underside of first HP substrate **111**, and on the underside of second HP substrate **112**. In addition, each of the HP switchable elements **320**, **420** is coupled to a controller (not shown) via a DC circuit **327**, **427** and DC line. The controller controls the operation of each HP switchable element **320**, **420**, such that HP switchable elements **320**, **420** may be in an “ON” operational mode or an “OFF” operational mode.

[63] When one of HP switchable elements **320**, **420** is in the “ON” operational mode, it acts like a resistor equivalent to the serial resistance of HP switchable elements **320**, **420** (*e.g.*, to the serial resistance of the constituent PIN diode). The shortening vias **325**, **425** introduce an open circuit to the corresponding first feeding port **330** or second feeding port **430**. In turn, the associated IFA **310**, **410** becomes disconnected from its corresponding feeding port **330**, **450**. In an exemplary embodiment, the distance between feeding port **330**, **430** and the shortening (ground) vias **325**, **425** may be a quarter of a guided wavelength (*e.g.*, approximately 9.6 mm at 6.5 GHz, for a microstrip line with a 1 mm thickness of FR4 substrate).

[64] The process of switching HP switchable elements **320**, **420** between the “ON” and “OFF” operational modes allows for the modification and control of a horizontally-polarized radiation pattern of antenna structure **100**. In some embodiments, by controlling HP switchable elements **320**, **420** it is possible to modify the direction of operation of antenna structure **100**, including direction of radiation and reception of the RF waves.

[65] As depicted, each of IFAs **310**, **410** is electrically coupled to a respective matching circuit **335**, **435**. Each matching circuit **335**, **435** is configured with a first capacitor **331**, **431**, a second capacitor **332**, **432**, and a quarter wavelength transformer disposed between the IFA and central feeding ports **330**, **430**. Matching circuits **335**, **435** are connected to feeding port **330**, **430**, respectively.

[66] When one of the HP switchable elements **320**, **420** is in the “OFF” operational mode, the respective IFA **310**, **410** is electrically connected to first RF ports **330**, **430** via matching circuits **335**, **435**. The matching circuits **335**, **435** enable the matching of a 50Ω impedance of IFA **310**, **410** with a 50Ω impedance of respective feeding ports **330**, **430**.

[67] As shown in FIGs. 3A, 4A, feeding ports **330**, **430** are electrically coupled to shortening vias **325**, **425** by virtue of branches **333a**, **333b**, **333c**, **333d**, and **433a**, **433b**, **433c**, **433d**, respectively. The branches **333a-333d** and **433a-433d** are configured to match the 50Ω impedance of associated feeding ports **330**, **430**. The distance between feeding ports **330**, **430** and shortening vias **325**, **425** along branches **333a-333d** and **433a-433d** is approximately a quarter of the guided wavelength to maintain an open circuit for one of the branches **333a-333d** or **433a,- 433d**, as seen by the feeding point, when one diode is in “ON” operational mode.

[68] It should be appreciated that, while the described embodiments present four IFAs, this is done for illustrative purposes. For example, the first HP unit **101** and second HP unit **102** may comprise less than or more than four IFAs **310**, **410**, and a corresponding number of matching circuits may be provided to match 50Ω impedance of IFA **310**, **410** with 50Ω impedance of respective feeding port **330**, **430**.

[69] FIGs. 3A, 4A, illustrate that IFAs **310**, **410** positioned such that respective radiating arm portions **312**, **412** of IFAs **310**, **410** point in one direction relative to circumferences **301**, **401**. The depicted electric field polarization arrows **341a**, **341b**, **341c**, **341d** in FIG. 3A indicate that IFAs **310** may be configured to radiate an electric field with vectors that form a circle. This configuration of IFAs **310**, **410** serves to cancel out radiation in a direction normal to ground layer **315** and increases radiation at angles close to ground layer **315**. In this manner, the configuration of IFAs **310**, **410** operates to increase the range of radiated RF waves.

[70] In addition, the first HP unit **101** and the second HP unit **102** may also comprise directors **370**, **470** located along the longer sides of IFAs **310**, **410** as depicted in FIG. 3A, 4A. The directors **370**, **470** may be configured to adjust directional angles to further increase the radiation range of RF waves.

[71] In operation, when all first HP switchable elements **320** are in the “OFF” operational mode, first HP unit **101** may be configured to operate in an omnidirectional mode, such that first HP unit **101** is capable of radiating RF waves to, and receive RF waves, from any directional angle. Similarly, second HP unit **102** may also be configured to operate in the omnidirectional mode when all first HP switchable elements **420** are in the “OFF” operational mode. It will be appreciated that in the omnidirectional mode, the directional gain

of first HP unit **101** and second HP unit **102** may, at most, weakly relate to the angle of radiation with respect to the central axis A1 of antenna structure **100**.

[72] FIG. 5 depicts an underside view of antenna structure **100**, in accordance with at least one non-limiting embodiment. As noted above, the ground layers are electrically
5 coupled to ground vias **325**, **425**. As will be discussed in greater detail below, ground-bound electrical lines (not depicted in FIG. 5) of feeding supports **171a**, **171b**, **172a**, **172b** couple ground layers **315**, **415** to the electrical ground.

[73] As discussed above, antenna structure **100** includes a first VP unit **151** and a second VP unit **152** that are each configured to radiate and receive vertically polarized RF
10 waves. The first VP unit **151** comprises two first VP substrates **161a**, **161b**, and second VP unit **152** comprises two second VP substrates **162a** and **162b**.

[74] FIG. 6A depicts a front view of the first and second VP units **151**, **152**, which are mounted on first and second HP units **101**, **102**. FIGs. 6B depicts a back view of first and second VP units **151**.

15 [75] In the illustrated embodiment, first VP unit **151** includes an electric probe with four branches for exciting the vertical polarization. Each of the four branches is referred to herein as a first VP excitation element **615**. The second VP unit **152** also includes exciting electric probe with four branches, each branch referred to herein as a second VP excitation element **616**. Each VP excitation element **615**, **616** may be made of a conductive pattern or
20 region located on one of substrates **161a**, **161b**, **162a**, **162b**. The first and second VP excitation elements **615**, **616** are configured to radiate the EM field (RF signal) into the first and the second waveguides **201**, **202**, respectively.

[76] To excite the radiation in waveguides **201**, **202**, excitation portions (*i.e.*, probes) **625**, **626** of the excitation elements **615**, **616** are positioned to be substantially perpendicular
25 to the ground layers forming waveguides **201**, **202**. As waveguides **201**, **202** are parallel to each other, excitation portions **625**, **626** of excitation elements **615**, **616** are positioned substantially perpendicular to second HP substrate **112**.

[77] Excitation elements **615**, **616** may have various forms or patterns. The form of excitation elements **615**, **616** may be selected to match their impedance to the impedance of
30 waveguides **201**, **202**, respectively.

[78] The RF signal is received via a first and a second VP RF port **631**, **632**. These first and second VP RF ports **631**, **632** are, in the illustrated embodiment, located in central portions of the first and second VP units **151**, **152**.

[79] As depicted in FIG. **6B**, for some embodiments, a VP RF cable **193** is attached to first VP unit **151**. The VP RF cable **193** operates to supply the RF signal to first VP unit **151**. A second VP RF port **632** of second VP unit **152** is connected to RF supply via base unit **103**.

[80] In the illustrated embodiment, first VP substrates **161a** and **161b** are positioned substantially perpendicular to each other such that the four probes **615** are symmetrically distributed about central axis **A1** of antenna structure **100**. Similarly, the second VP substrates **161a** and **161b** are positioned substantially perpendicular to each other such that four probes **616** are symmetrically distributed about the central axis **A1** of antenna structure **100**.

[81] In the illustrated embodiment, first VP substrates **161a**, **161b** are positioned such that they cross each other at about central axis **A1** of antenna structure **100**. Second VP substrates **162a**, **162b** are also positioned such that they cross each other at about central axis **A1** of antenna structure **100**. In some embodiments, there may be one or more first VP substrates **161**, each having a suitable number of VP excitation elements **625**. It should be noted that antenna structure **100** may have any number of first and second VP substrates **161**, **162**, as long as they are symmetrically and evenly distributed about antenna central axis **A1** in first and second waveguides **201**, **202**, respectively.

[82] In the illustrated embodiment, each of the first VP excitation elements **615** is located at a substantially equal distance from central axis **A1** of antenna structure **100**. Similarly, each of the second VP excitation elements **616** is located substantially equal distance from central axis **A1** of antenna structure **100** with respect to the other second VP excitation elements **616**. Positioning VP excitation elements **615**, **616** symmetrically relative to each other permits achieving omnidirectional radiation of first VP unit **151** and second VP unit **152**, respectively. The distances between VP excitation elements **615**, **616** and the central axis **A1** may be determined by the width of the corresponding first and second waveguides **201**, **202**. It should be noted that in some embodiments, each of the first and second VP excitation elements **615**, **616** may be substantially equidistant from **A1**, while in other

embodiments, each of the first VP excitation elements **615** are substantially equidistant from **A1** but are a different distance from **A1** than the second VP excitation elements **616**.

[83] It will be appreciated that the substrates of first and second HP units **101**, **102** and first and second VP units **151**, **152** may be manufactured using various technologies, including, but not limited to, PCB technologies.

[84] Referring again to the embodiment of FIG. 6A, first VP unit **151** further comprises one or more first parasitic elements **635** located on first VP substrates **161**. The first parasitic elements **635** are positioned substantially in parallel to excitation portions **625** of the excitation elements **615**. The second parasitic elements **636** are located on second VP substrates **162** substantially in parallel to the excitation portions **626** of the excitation elements **616**. Each first and second parasitic element **635**, **636** is located further away from central axis **A1** compared to corresponding excitation portions **625**, **626** of the corresponding excitation elements **615**, **616**.

[85] A first parasitic element **635** may be electrically connected to one or both of first HP unit **101** and second HP unit **102**. As shown, first parasitic elements **635** are mechanically and electrically connected to first HP unit **101**. The electrical connection may be achieved, in some embodiments, by soldering parasitic elements **635** to RF connecting pads **381** after inserting protruding portions of first VP substrate **161** in apertures **361** in first HP unit **101**.

[86] Referring now to the embodiments of FIGs. 2 and 3A, first parasitic elements **635** are electrically connected to first VP switchable elements **382a**, **382b**, **382c**, **382d** (also referred to herein as first switchable elements **382**) located on first HP unit **101**. In the illustrated embodiment, first VP switchable elements **382** are each connected to a parasitic feeding circuit **386** having resistors **385**. Each parasitic feeding circuit **386** is connected to a VP DC line connector **390** that is electrically connected to a VP DC line **711** located on a surface of first feeding support **171**. It should be clear to those skilled in the art that these features of the different illustrations can be implemented independently of the other features of those figures.

[87] In the embodiment depicted in FIG. 2, first VP substrate **161** includes protruding portions **282**. The protruding portions **282** of first VP substrates **161** and first VP apertures **361** of first HP unit **101** are dimensioned such that VP apertures **361** can receive protruding

portions **282** to mount the first HP substrate **111** onto first VP substrate **161**. The protruding portions **282** mechanically and electrically connect the first parasitic elements **635** to RF connecting pads **381**, which are coupled to first VP switchable elements **382**. As noted above, the first VP switchable elements **382** are configured to control operation of parasitic elements **635**. The VP switchable elements **382** comprise PIN diodes, varicaps, or microelectromechanical systems (MEMS) elements.

[88] The excitation elements **615** and parasitic elements **635** are spaced apart from each other on first VP substrate **161**. When VP switchable element **382** is in the “ON” operational mode, parasitic elements **635** operates to block the RF wave emitted by the corresponding excitation element **615**. It should be noted that parasitic elements **635**, **636** and VP excitation elements **615**, **616** may be located on the same surface of VP substrates **161**, **162** or on opposite surfaces of VP excitation elements **615**, **616**.

[89] When VP switchable element **382** is in the “ON” operational mode, parasitic element **635** blocks reception of the RF wave at the corresponding excitation element **615**. When all VP switchable elements **382** are in the “OFF” operational mode, parasitic elements **635** permit the omnidirectional radiation of RF wave that is vertically polarized. Switching VP switchable elements **382** between the “ON” and “OFF” operational modes enables the modification and control of the radiation pattern of antenna structure **100**. The ability to switch between “ON” and “OFF” modes enables the generation of omnidirectional radiation patterns or generation of directional radiation patterns.

[90] For example, when two neighboring first VP switchable elements **382** (*e.g.* **382a**, **382b** in FIG. 3A) are in the “ON” operational mode at the same time and the other first VP switchable elements **382** (*e.g.* **382c**, **382d**) are in the “OFF” mode, antenna structure **100** generates a directional radiated pattern having a higher gain as compared with the omnidirectional pattern.

[91] It should be understood that first VP substrate **161** may have any number of protrusions **282** matching corresponding apertures in first HP substrate **111** for mounting of first HP substrate **111** on first VP substrate **161**.

[92] As noted above, second VP substrates **162a**, **162b** are mounted on base unit **103** and second parasitic elements **636** are electrically connected to second VP switchable

elements **520** located on base unit **103**. Referring again to FIG. 5, base unit **103** further comprises second VP switchable elements **520** which are connected to corresponding RF connecting pads **581** via a DC circuit. By mounting second VP substrate **162** to base unit **103**, parasitic elements **636** of second VP unit **152** are electrically connected to second VP switchable elements **520**. The electrical connection may be achieved by soldering parasitic elements **636** to RF connecting pads **581** after inserting protruding portions **286** of second VP substrate **162** in second VP apertures **561** in base unit **103**. Similar to the operation of first VP unit **151**, by switching between “ON” and “OFF” operational modes, the second VP switchable elements **382** control the radiation pattern of second VP unit **152**.

10 [93] In some embodiments, first and second HP units **101**, **102** and first and second VP units **151**, **152** may operate in a similar RF frequency range. For example, all HP and VP units **101**, **102**, **151**, **152** may operate at a frequency range of 5 gigahertz (GHz) or 6 GHz. In other embodiments, the first HP unit **101** and second VP unit **152** may operate in a first frequency range, while second HP unit **102** and first VP unit **151** operate in a second frequency range. The first frequency range may comprise frequencies that are lower than the frequencies of the second frequency range. For example, the first frequency range may comprise 5 GHz and the second frequency range may comprise 6 GHz.

15 [94] In certain embodiments, the first frequency range may overlap with the second frequency range. For example, a difference between the first frequency range and the second frequency range may be about or more than 1 GHz, such that the first frequency range includes 5 GHz and the second frequency range includes 6 GHz.

20 [95] In certain embodiments, the first HP unit **101** may be disposed further away from main ground layer **515**, which is positioned on a top surface of base unit **103**. This enables first HP unit **101** to operate in a frequency range that includes lower frequencies as compared to the operation of the frequency range of the other HP unit.

25 [96] The first and second VP units **151**, **152** may be configured to radiate the RF wave in the same frequency ranges. Alternatively, first and the second VP units **151**, **152** may be configured to radiate in two different frequency ranges. In some embodiments, first VP unit **151** may be configured to radiate in 5 GHz frequency range and the second VP unit **152** may be configured to radiate the RF wave in 6 GHz frequency range.

[97] It should be understood that the configuration of the excitation elements **615**, **616** depends on the frequency bandwidth of RF wave that is radiated by the excitation elements. In some embodiments, excitation portions **626** of VP excitation elements **616** operating at 6GHz may be located closer to central axis A1 of antenna structure **100**, as compared to VP excitation elements **615** operating at 5GHz.

[98] Referring again to FIGs. 3A-4B, first HP unit **101** comprises feeding apertures **360**, and second HP unit **102** comprises feeding apertures **460**. Moreover, as shown in FIG. 1, feeding apertures **360** of first HP unit **101** are configured to receive first protruding portions **281** of feeding supports **171**. Feeding apertures **460** of second HP unit **102** are configured to receive second protruding portions **283**, **284** of feeding supports **171**, **172**, respectively. The first HP unit **101** has VP apertures **361** for receiving protruding portions **282** of first VP substrates **161**. The second HP unit **102** may also have additional apertures for receiving protruding portions of first and second VP substrates **161a**, **161b**, **162a**, **162b**.

[99] FIGs. 7A, 7B depict front and back side view of feeding supports **171**, **172** mounted on the first and second HP units **101**, **102** of antenna structure **100** in accordance with embodiments of the present disclosure. The pair of first feeding supports **171a**, **171b** (also referred to herein as “first feeding supports **171**”) and the pair of second feeding supports **172a**, **172b** (also referred to herein as “second feeding supports **172**”) are configured to provide direct electrical current or voltage from base unit **103** to first HP unit **101** and second HP unit **102**. In particular, feeding supports **171**, **172** may provide direct electrical current/voltage to first HP switchable elements **320**, second HP switchable elements **420** and first VP switchable elements **382**.

[100] Each of the first feeding supports **171a**, **171b** contains a pair of two DC lines **711**, **712**. The DC lines **711**, **712** provide a current and voltage to the first HP unit **101** and, in particular, to first HP switchable elements **320** and first VP switchable elements **382** located on first HP unit **101**.

[101] Each of the second feeding supports **172a**, **172b** contains a pair of three DC lines **721**, **722**, **723**. The DC lines **721**, **722** provide a current and voltage to first HP switchable elements **320** and first VP switchable elements **382** located on first HP unit **101**. The third DC line **723** provides a current and voltage from base unit **103** to second HP switchable elements **420** located on second HP unit **102**.

[102] In a DC junction area 750, portions of first and second feeding supports 171, 172 and a portion of second HP unit 102 are configured to transmit DC current from second feeding support 172 to first feeding support 171. The DC lines 721, 722 are electrically connected to DC lines 711, 712 of first feeding supports 171a, 171b on the second HP unit 102. In some embodiments, DC lines 711 and DC lines 721 of the corresponding first and second feeding supports 171 and 172 may be soldered to a corresponding common second DC conducting pad 490 located on HP unit 102. Similarly, DC lines 712, 722 of the corresponding first and second feeding supports 171 and 172 are soldered to another corresponding common second DC conducting pad 490 located on HP unit 102.

[103] As depicted in FIG. 7B, feeding supports 171, 172 also comprise feeding ground layers 705, 706 which are configured to provide electrical ground to first and second HP units 101, 102 from base unit 103. The feeding ground layers 705, 706 of feeding supports 171, 172 may be made of a metal material, such as, for example, copper. In the illustrated embodiment, feeding ground layers 705, 706 are located on the surface of feeding supports 171, 172 that are opposite to the surfaces bearing DC lines 711, 712 and 721, 722, respectively.

[104] In the junction area 750, feeding ground layers 706 of second feeding supports 172 are electrically connected to feeding ground layers 705 of first feeding supports 171. Referring also to FIG. 4A, feeding ground layers 705, 706 may be connected to second ground conducting pads 488, for example by soldering. In some embodiments, the soldering may be performed after inserting protruding portions 283 of feeding supports 171 in apertures 460 in second HP unit 102. In some embodiments, first and second feeding supports 171, 172 have protruding portions in order to couple them with second HP unit 102.

[105] Referring again to FIG. 5, base unit 103 of antenna structure 100 comprises base feeding apertures 560 for receiving protruding portions 285 of second feeding supports 172a, 172b. In some embodiments, second feeding supports 172a, 172b are mounted on base unit 103 by inserting protruding portions 285 of second feeding supports 172 into matching base feeding apertures 560 in base unit 103.

[106] The base unit 103 also has VP apertures 561 for receiving protruding portions 286 of second VP substrates 162a, 162b. It should be understood that there may be any number of

protruding portions **285** of second feeding supports **172a**, **172b** and any number of protruding portions **286** of second VP substrates **162a**, **162b** with matching apertures in base unit **103**.

[107] As shown in FIG. 5, the base feeding apertures **560** are adjacent to base DC conducting pads **590** and base ground conducting pads **588** that are located on the underside of base unit **103**. Each DC conducting pad **590** is electrically connected to a controller (not shown) via a power connector **550** (DC and RF lines are not depicted in FIG. 5B for purposes of simplification). The base DC conducting pads **590** are positioned such that, when second feeding supports **172** are mounted on base unit **103** and protruding portions **285** of second feeding supports **172** are received by base feeding apertures **560**, conducting pads **590** are electrically connected to DC feeding lines **721**, **722**, **723** located on feeding supports **172**.

[108] Each feeding line **721**, **722**, **723** provides DC current to one of switching elements of antenna structure **100**. Such switchable elements are: first switchable elements **320** configured to operate IFAs of first HP unit **101**; second switchable elements **420** configured to operate IFAs of second HP unit **102**; and VP switchable element **382** configured to operate first parasitic elements **635**.

[109] Referring to FIGs. 1-2 and 4A-5B, base unit **103** and second HP unit **102** may incorporate cable apertures **485**, **585** for passing RF cables **191**, **193** that provide RF signal to first feeding port **330** of first HP unit **101** and to first VP unit **101**, respectively. The base unit **103** may also have an additional cable aperture **585** for passing RF cable **192** configured to provide RF signal to second HP feeding port **430**.

[110] To manufacture antenna structure **100**, first HP antenna unit **101**, second HP antenna unit **102**, and base **103** may be first manufactured separately. All surface mounted components, such as, for example, first and second HP switchable elements **320**, **420**, capacitors **331**, **431**, **332**, **432**, first VP switchable elements **382**, resistors **385**, matching circuits **335**, **435**, second VP switchable elements **520**, power connector **550**, *etc.*, may be assembled using standard techniques and processes.

[111] Referring to FIGs. 5-7B, the second VP substrates **162a**, **162b** and second feeding supports **172a**, **172b** may be then mounted on base unit **103**. The second parasitic elements **636** may then be connected to RF connecting pads **581** on base unit **103**. The excitation elements **626** may be connected to RF signal pad **595**. The ground layers **706** may be

connected to base ground conducting pads **588**. The DC connecting lines **721**, **722**, **723** may be connected to base DC conducting pads **590** on base unit **103**. These elements may be connected to each other, *e.g.* by soldering, to form a first sub-assembly.

[112] To manufacture a second sub-assembly, first HP RF cable **191** may be attached to first HP unit **101**, *e.g.* by soldering inner conductor of first HP RF cable **191** to first feeding port **330** on top surface **305** and soldering shield to ground layer **315** of first HP unit **101**. First VP substrates **161a**, **161b** may then be attached to first HP unit **101**.

[113] Referring to FIG. 6B, an inner conductor of VP RF cable **193** may then be attached to first VP RF port **631** on at least one of first VP substrate **161a** and **161b** and a shield of VP RF cable **193** may be soldered to a VP ground pad **634**. Electrical connections between first parasitic elements **635** and RF connecting pads **381** on first HP unit **101** (as depicted in FIG. 1), may also be soldered. The first HP unit **101** with attached cable **191** and first VP substrates **161** with attached cable **193** form the second sub-assembly.

[114] In some embodiments, antenna structure **100** may also comprise a VP feed substrate (not shown in drawings) that may be located in first waveguide **201** and positioned in a parallel manner to first and second substrates **111**, **112**. Such VP feed substrate may have apertures to receive portions of first feeding supports **171** and first VP substrates **161**. VP RF cable **193** may be attached to the VP feed substrate and the VP feed substrate may then be soldered to first VP substrates **161** when mounting of the second sub-assembly.

[115] To manufacture a third sub-assembly, second HP RF cable **192** is attached to second HP unit **102**, such as, for example, by soldering an inner conductor of the second HP RF cable **192** to second feeding port **430** of second HP unit **102** and soldering a shield of the second HP RF cable **192** to second ground layer **415** of second HP unit **102**. In some embodiments, the first, the second, and the third sub-assemblies may be manufactured in any order relative to each other.

[116] To manufacture a fourth sub-assembly, second HP unit **102** having attached cable **192** is subsequently mounted on protruding portions **284** of second feeding supports **172** of the first sub-assembly. The first feeding supports **171** may then be installed on top surface **405** of second HP unit **102**. DC connecting lines **721**, **722**, **723** and **711**, **712** are connected to second DC conducting pads **490** located in second HP unit **102**. This provides continuity of

DC signals between first DC connecting lines **721**, **722**, **723** located on second feeding supports **172** and first DC connecting lines **711**, **712** located on first feeding supports **171**.

[117] Feeding ground layers **706** and **705** are connected to second ground conducting pads **488** of second HP unit **102**, providing continuous ground plane. Performing this step before installing first HP unit **101** allows for access to solder areas. It should be noted that second ground pads **488** are connected to second ground layer **415** by ground vias **426**.

[118] The second and fourth sub-assemblies may then be connected by mounting first HP unit **101** with attached cable **191** and first VP substrates **161** with attached cable **193** on top of feeding supports **171**. Electrical connections between DC connecting lines **711**, **712** of first supports **171** may then be soldered to VP DC line connectors **390** on first HP unit **101**. Feeding ground layers **705** may be soldered to first ground conducting pads **388** on top of first HP unit **101**.

[119] FIG. 13 illustrates a flowchart describing method **1300** for manufacturing an antenna structure for the communication of a radio-frequency (RF) wave, in accordance with the disclosed embodiments of the present disclosure. Method **1300** commences at step **1310** in which IFAs **310**, **410** and switchable elements **320**, **420** are attached to first HP substrate **111** of first HP antenna unit **101** and second HP substrate **112** of second HP antenna unit **102**, respectively. Other corresponding electronic components, such as capacitances, resistors and various conducting pads and DC line connectors (*e.g.* RF connecting pads **381**, first and second ground conducting pads **388**, **488**, VP DC line connector **390**, HP DC line connector **391**), may be attached to first HP antenna unit **101** and second HP antenna unit **102**, as described above.

[120] At step **1312**, VP excitation elements **635**, **636** are attached to first and second VP antenna units **151**, **152**. At step **1314**, first HP RF cable **191** is attached to first HP antenna unit **101**. At step **1316**, first VP RF cable **193** is attached to first VP antenna unit **151**. As discussed above, first HP RF cable may be attached by soldering inner conductor on top surface **305** of first HP antenna unit **101** and soldering shield on underside surface **306** of first HP antenna unit **101**.

[121] At step **1320**, first VP substrates of first VP antenna unit **151** are coupled to first HP antenna unit **101** by inserting protruding portions of first VP substrates **161** into matching

apertures **361** of first HP substrate **111**. At step **1322**, parasitic elements **635**, located at least partially on the protruding portions of first VP substrates **161**, are electrically connected to corresponding RF connecting pads **381** located on first HP substrate **111**.

[122] At step **1324**, second HP RF cable **192** is attached to second HP antenna unit **102**.

5 At step **1326**, second feeding supports **172** and second VP substrates **162** are coupled to base unit **103** by inserting protruding portions of second feeding supports **172** and second VP substrates **162** into matching apertures **560**, **561** of base unit **103**. In some embodiments, steps **1314**, **1316**, **1324**, **1326** may be performed in any order relative to each other.

[123] At step **1330**, second HP antenna unit **102** is coupled to first feeding supports **171**

10 and second feeding supports **172** by inserting protruding portions of first feeding supports **171** and second feeding supports **172** into matching apertures **460** in the second HP substrate **112** of the second HP antenna unit **102**.

[124] At step **1332**, DC lines **711**, **712**, **721**, **722** and feeding ground layers **705**, **706** are

15 electrically connected to corresponding second DC conducting pads **490** and second ground pads **488**, respectively, which are located on second HP substrate **112**. As indicated in the illustrated embodiments of FIGs. 7A, 7B, DC lines **711**, **712**, **721**, **722** and feeding ground layers **705**, **706** may be located partially on second protruding portions **284** of first feeding supports **171** and on first protruding portions **283** of second feeding supports **172**.

[125] At step **1334**, first HP unit **101** is coupled to first feeding supports **171** by

20 inserting other protruding portions **281** of first feeding supports **171** into matching apertures **360** in first HP substrate **111** of first HP antenna unit **101**. And, finally, at step **1336**, DC lines **711**, **712** and feeding ground layers **705**, which are positioned at least partially on the other protruding portions **281** of first feeding supports **171**, are electrically connected to corresponding first VP DC line connectors **390**, first HP DC line connectors **391**, and first

25 ground pads **388** that are located on first HP substrate **111**.

[126] In some embodiments, attaching first VP RF cable **193** to first VP antenna unit

151 may include first attaching first VP RF cable **193** to the VP feeding substrate (not illustrated). An inner conductor of first VP RF cable **193** may be soldered on top and a shield of VP RF cable **193** may be soldered on an underside of the VP feeding substrate. The VP

30 feeding substrate may then be coupled to first VP substrates **161** in a substantially

perpendicular manner, and an RF feed point may be soldered to connect the VP feeding substrate and first VP substrates **161** of first VP unit **151**. The first HP substrate **111**, with attached first HP cable **191**, may then be coupled with first VP substrates **161** of first VP unit **151**. The protruding portions **282** of first VP substrates **161** are coupled with matching
5 apertures **361** in first HP substrate **111** and portions of parasitic elements are soldered with RF connecting pads **381** to electrically connect first VP unit with VP switching elements **382** located in first HP unit **101**. The VP feeding substrate becomes located approximately in parallel with first HP substrate **111** and second HP substrate **112** in first waveguide **201**.

[127] FIG. 8A depicts azimuthal radiation patterns of second VP unit **152** of antenna structure **100**, in accordance with the disclosed embodiments of the present disclosure. FIG. 8B depicts reflection coefficient (*i.e.*, S_{11} -parameter) of second VP unit **152** of antenna structure **100**, where second VP unit **152** operates in the 5 GHz frequency range. Curves **801**, **811** illustrate the generated omnidirectional radiation pattern and reflection coefficient, respectively, of antenna structure **100** operating in an omnidirectional mode in which all four
15 second VP switchable elements **520** of second VP unit **152** are in the “OFF” mode.

[128] As noted above, VP units **151**, **152** may operate in a directional mode in which two VP switchable elements **520** or **382** are in the “ON” mode. Curves **802**, **803**, **804**, **805** illustrate the generated directional radiation patterns and corresponding S_{11} -parameters **812**, **813**, **814** **815**, respectively, for different radiated directions of second VP unit **152**.

[129] FIG. 9A depicts azimuth directional radiation patterns of operation of second VP unit **152** of antenna structure **100**, when one, two, or three HP switchable elements are in the “ON” operation mode, in accordance with the embodiments of the present disclosure. As noted above, when second VP switchable elements **520** are in the “ON” mode, parasitic elements **636** block radiation of second VP excitation elements **626**. Thus, curve **901** depicts
25 the radiation pattern when a second VP switchable element **520** is in the “ON” operational mode, curve **902** depicts the radiation pattern when two second VP switchable elements **520** are in the “ON” operational mode, and curve **901** depicts radiation pattern when three second VP switchable elements **520** are in the “ON” operational mode. Moreover, FIG. 9B depicts a return loss for second VP unit **152** of antenna structure **100** of FIG. 9A. That is, curve **911**
30 depicts the return loss when one second VP switchable element **520** is in the “ON” operation mode, curve **912** depicts the return loss when two second VP switchable elements **520** are in

the “ON” operation mode, and curve **911** depicts return loss when three second VP switchable elements **520** are in the “ON” operation mode.

[130] As described above, antenna structure **100** may be configured to operate in two frequency ranges and in two polarizations. Moreover, antenna structure **100** may be configured to switch between omnidirectional and directional operation modes.

[131] FIG. 10 depicts an antenna array **1000** in accordance with disclosed embodiments of the present disclosure. Antenna array **1000** comprises antennas **100** and third antenna units **1003**. In some embodiments, antenna units **1003** may operate in a third frequency range, such as, for example, 2.5 GHz. Moreover, antenna units **1003** may be configured to generate radiation patterns that are vertically and horizontally polarized. In some embodiments, each antenna unit **1003** may comprise a third IFA configured to operate in the third frequency range having horizontal polarizations and a monopole element configured to operate in a third frequency range having vertical polarization. In so doing, antenna array **1000** may be configured to operate in three frequency ranges.

[132] In the illustrated embodiment, antenna array **1000** may be reconfigurable to operate in two polarizations (vertical and horizontal) and three frequency ranges. In some embodiments, antenna array **1000** may accommodate **16** ports per band (*i.e.* 16 data streams). Four ports of antenna structure **100** may be collocated, as described herein, to reduce the size of antenna array **1000**. Such a configuration, enables antenna array **1000** to perform omnidirectional and directional mode operations in two bands (e.g. **5** GHz and **6** GHz).

[133] The 16 data streams of antenna array **1000** enable the use of Multi Input Multi Output (MIMO) technology, which helps to increase communication capacity. The mode switching capability of antenna structure **100** further increases the communication capacity, as it reduces undesired interferences and enhances transmission and reception gains.

[134] FIG. 11 depicts return loss curves, *i.e.* S_{11} -parameter, for first VP unit **151** operating in the 6 GHz frequency range (curve **1106**) and second VP unit **152** operating in 5 GHz frequency range (curve **1105**), in accordance with the disclosed embodiments of the present disclosure. FIG. 11 further depicts the coupling coefficient, *i.e.* S_{21} -parameter, between first VP unit **151** and second VP unit **152** (curve **1107**), as a function of frequency for VP excitation elements of antenna structure **100**. As indicated, coupling between first and

second VP units **151**, **152** was substantially low, such that the S_{21} -parameter was less than -20 dB (curve **1107**).

[135] FIGs. 12A, 12B respectively illustrate the azimuthal radiation patterns of first HP unit **101** (curves **1201** and **1203**) and second HP unit **102** (curves **1202** and **1204**), of antenna structure **100**, in accordance with the disclosed embodiments of the present disclosure. The first HP unit **101** operates at a 5 GHz frequency range and second HP unit **102** operates at a 6 GHz frequency range, respectively. Solid curves **1201**, **1202** depict the radiation patterns for directional mode operation when two switchable elements **320**, **420** of first and second HP units **101**, **102** are in the “ON” operation mode. Dashed curves **1203**, **1204** depict the radiation patterns for omnidirectional mode operation when all switchable elements **320**, **420** are in the “OFF” operation mode.

[136] FIG. 12C depicts the return loss for first HP unit **101** (curve **1211**) and for second HP unit **102** (curve **1212**). In the illustrated embodiment, first HP unit **101** operates in the 5 GHz frequency range and second HP unit **102** operates in the 6 GHz frequency range.

[137] Although the present invention has been described with reference to specific features and embodiments thereof, it is evident that various modifications and combinations can be made thereto without departing from the invention. The specification and drawings are, accordingly, to be regarded simply as an illustration of the invention as defined by the appended claims, and are contemplated to cover any and all modifications, variations, combinations or equivalents that fall within the scope of the present invention.

WHAT IS CLAIMED IS:

1. An antenna structure for communication of radio-frequency (RF) waves, the antenna
5 structure comprising:
 - a base unit;
 - a first horizontal-polarization (HP) antenna unit including a plurality of first inverted-F antennas (IFAs) configured to radiate RF waves with a horizontal polarization;
 - 10 a second HP antenna unit having a plurality of second IFAs configured to radiate RF waves with the horizontal polarization, the second HP antenna unit positioned such that the first HP antenna unit and the second HP antenna unit are spaced apart from each other to form a first parallel-plate waveguide, and such that the second HP antenna unit and the base unit are spaced apart from
15 each other to form a second parallel-plate waveguide;
 - a first vertical-polarization (VP) antenna unit located in the first parallel-plate waveguide, the first VP antenna unit having a plurality of first VP excitation elements configured to radiate the RF waves having vertical polarization; and
 - a second VP antenna unit located in the second parallel-plate waveguide, the
20 second VP antenna unit having a plurality of second VP excitation elements configured to radiate the RF waves with the vertical polarization.
2. The antenna structure of claim 1, further comprising:
 - a first plurality of HP switchable elements, each being connected to one of the
25 first IFAs, the first plurality of HP switchable elements being configured to control a radiation pattern of the first HP antenna unit.
3. The antenna structure of claim 2, further comprising:

a second plurality of HP switchable elements, each being connected to one of the second IFAs, the second plurality of HP switchable elements being configured to control the radiation pattern of the second HP antenna unit.

- 5 4. The antenna structure of any one of claims 1 to 3, wherein the first VP antenna unit and the second VP antenna unit further comprise parasitic elements for controlling a radiation pattern of the RF waves by the first VP antenna unit and the second VP antenna unit.
- 10 5. The antenna structure of claim 4, wherein the parasitic elements are operated by VP switchable elements located in at least one of the first HP antenna unit and the second HP antenna unit.
6. The antenna structure of any one of claims 1 to 5, wherein the first VP excitation elements form a first VP exciting probe, and the second VP excitation elements form a second VP exciting electric probe.
- 15 7. The antenna structure of any one of claims 1 to 6, further comprising:
 a pair of second feeding supports and a pair of first feeding supports configured
20 to provide electrical current to a first plurality of HP switchable elements, a second plurality of HP switchable elements and a first plurality of VP switchable elements.
8. The antenna structure of claim 7, wherein the pair of second feeding supports is
25 configured to provide direct current to a second plurality of VP switchable elements.
9. The antenna structure of any one of claims 1 to 8, wherein the first HP antenna unit comprises a first HP substrate having apertures for receiving protruding portions of first VP substrates of the first VP antenna unit.
- 30 10. The antenna structure of claim 9, wherein the received protruding portions of the first VP substrates are configured to electrically connect first parasitic elements located on

the first VP substrates and a first plurality of VP switchable elements, the first plurality of VP switchable elements being located on the first HP substrate and configured to operate the first parasitic elements for controlling a radiation pattern of the second VP antenna unit.

5

11. The antenna structure of claim 10, wherein the first HP substrate comprises apertures for receiving protruding portions of first feeding supports configured to electrically connect the first plurality of VP switchable elements to first DC lines located on surfaces of the first feeding supports.

10

12. The antenna structure of any one of claims 9 to 11, wherein the second HP antenna unit comprises a second HP substrate having apertures for receiving other protruding portions of the first VP substrates of the first VP antenna unit.

15

13. The antenna structure of claim 12, wherein
the base unit comprises a second plurality of VP switchable elements configured to operate second parasitic elements for controlling a radiation pattern of the second VP antenna unit, the second parasitic elements being electrically connected to the second plurality of VP switchable elements.

20

14. The antenna structure of any one of claims 1 to 13, wherein the second HP antenna unit further comprises:

apertures configured to receive protruding portions of second feeding supports comprising portions of second DC lines and second feeding ground layers;

25

DC conducting pads located on the second HP antenna unit and configured to electrically connect first DC lines located on first feeding supports to the second DC lines located on the second feeding supports, and

30

ground conducting pads located on the second HP antenna unit and configured to electrically connect first feeding ground layers located on first feeding supports to the second feeding ground layers located on the second feeding supports.

15. The antenna structure of any one of claims 1 to 14, wherein each of the first HP antenna unit, the second HP antenna unit, the first VP antenna unit, the second VP

antenna unit, and base unit comprise at least one substrate made of a printed circuit board (PCB).

16. The antenna structure of any one of claims 1 to 15, wherein
- 5 the first HP antenna unit and the second VP antenna unit are configured to operate in a first frequency range; and
- the second HP antenna unit and the first VP antenna unit are configured to operate in a second frequency range.
- 10 17. The antenna structure of claim 16, wherein the first frequency range overlaps with the second frequency range.
18. The antenna structure of any one of claims 16 and 17, wherein a difference between the first frequency range and the second frequency range is more than 1 gigahertz
- 15 (GHz).
19. The antenna structure of claim 18, wherein the first frequency range comprises frequencies that are lower than frequencies of the second frequency range.
- 20 20. The antenna structure of claim 19, wherein the first frequency range comprises 5 GHz and the second frequency range comprises 6 GHz.
21. The antenna structure of any one of claims 1 to 20, wherein the antenna structure is one of a plurality of antenna structures forming an antenna array, and the antenna
- 25 array further comprises a plurality of third antenna units, each third antenna unit having a monopole configured to radiate the RF waves being vertically polarized in a third frequency range and a third IFA configured to radiate the RF waves being horizontally polarized.
- 30 22. The antenna structure of claim 21, wherein the third frequency range comprises 2.5 GHz.

23. A method for manufacturing an antenna structure for transmission of a radio-frequency (RF) waves, the method comprising:

attaching inverted F antennas (IFAs) and switchable elements to a first horizontal-polarization (HP) substrate of a first HP antenna unit and a second HP substrate of a second HP antenna unit;

attaching first and second vertical-polarization (VP) excitation elements and first and second parasitic elements to first VP substrates and second VP substrates;

attaching a first HP RF cable to the first HP antenna unit, attaching a first VP RF cable to one of first VP substrates, and attaching a second HP RF cable to a second HP antenna unit;

coupling the first VP substrates to the first HP antenna unit and electrically connecting the first parasitic elements located on the first VP substrates to corresponding first RF connecting pads located on the first HP substrate;

attaching second feeding supports and second VP substrates to a base unit;

coupling the second HP antenna unit to first feeding supports and the second feeding supports and electrically connecting first and second DC lines and first and second feeding ground layers located on the first feeding supports and on the second feeding supports to corresponding second DC conducting pads and second ground pads located on the second HP substrate; and

coupling the first HP unit to the first feeding supports and electrically connecting the first DC lines and the first feeding ground layers located on the first feeding supports to corresponding first DC conducting pads and first ground pads located on the first HP substrate.

24. The method of claim 23, wherein attaching the first VP RF cable to the first VP antenna unit further comprises attaching the first VP RF cable to a VP feeding substrate and placing the VP feeding substrate approximately in parallel to the first HP substrate and the second HP substrate.

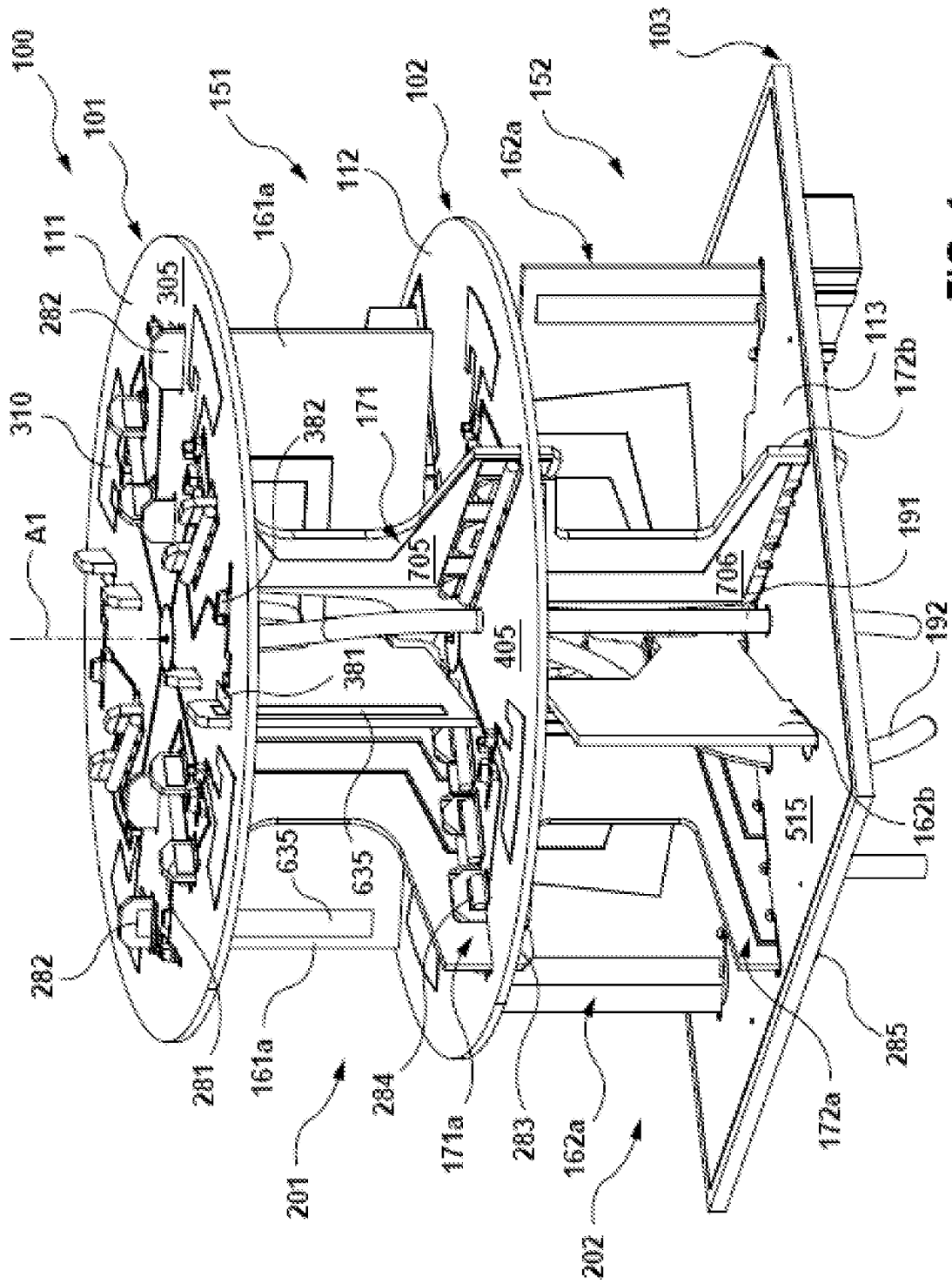

FIG. 1

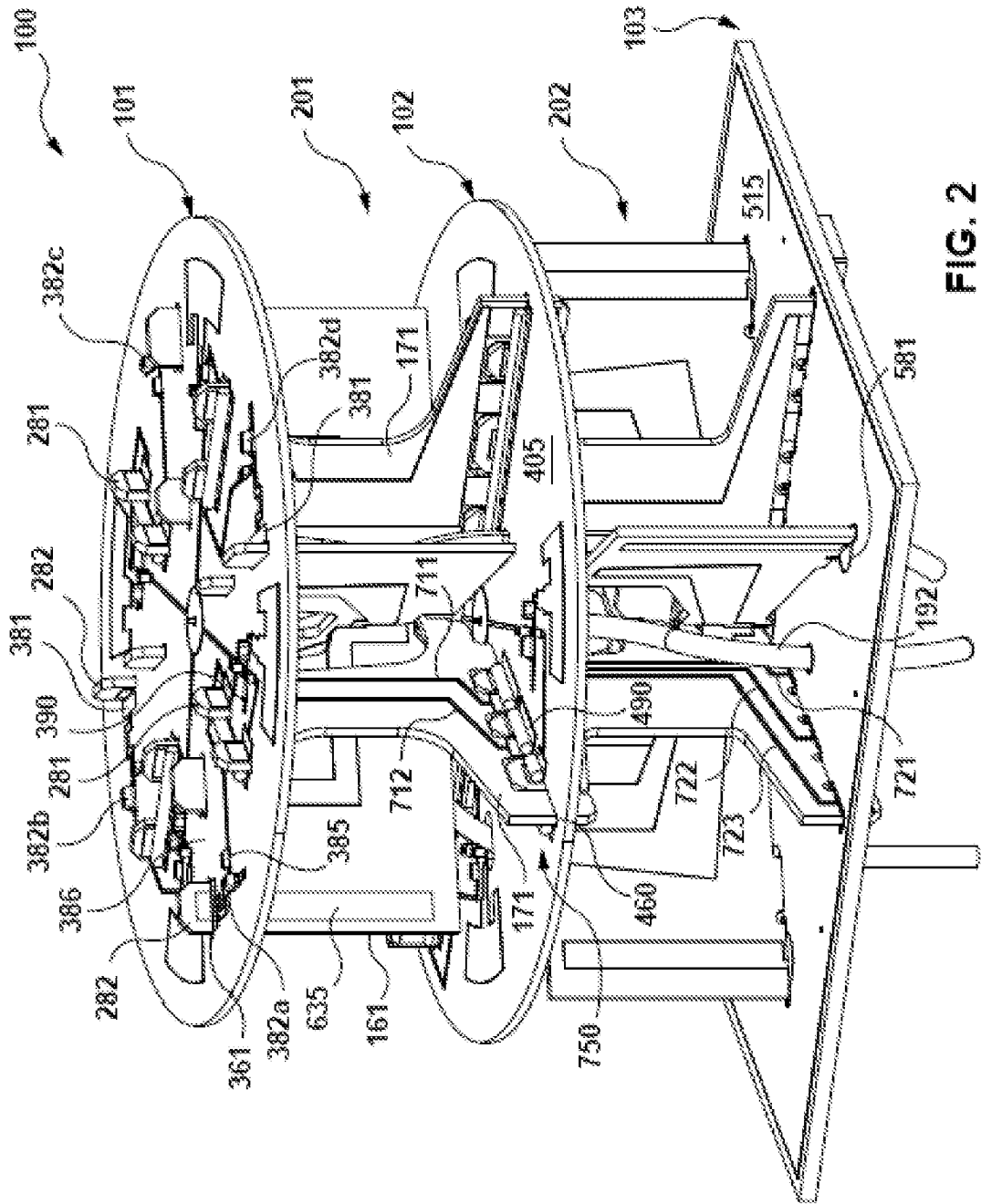

FIG. 2

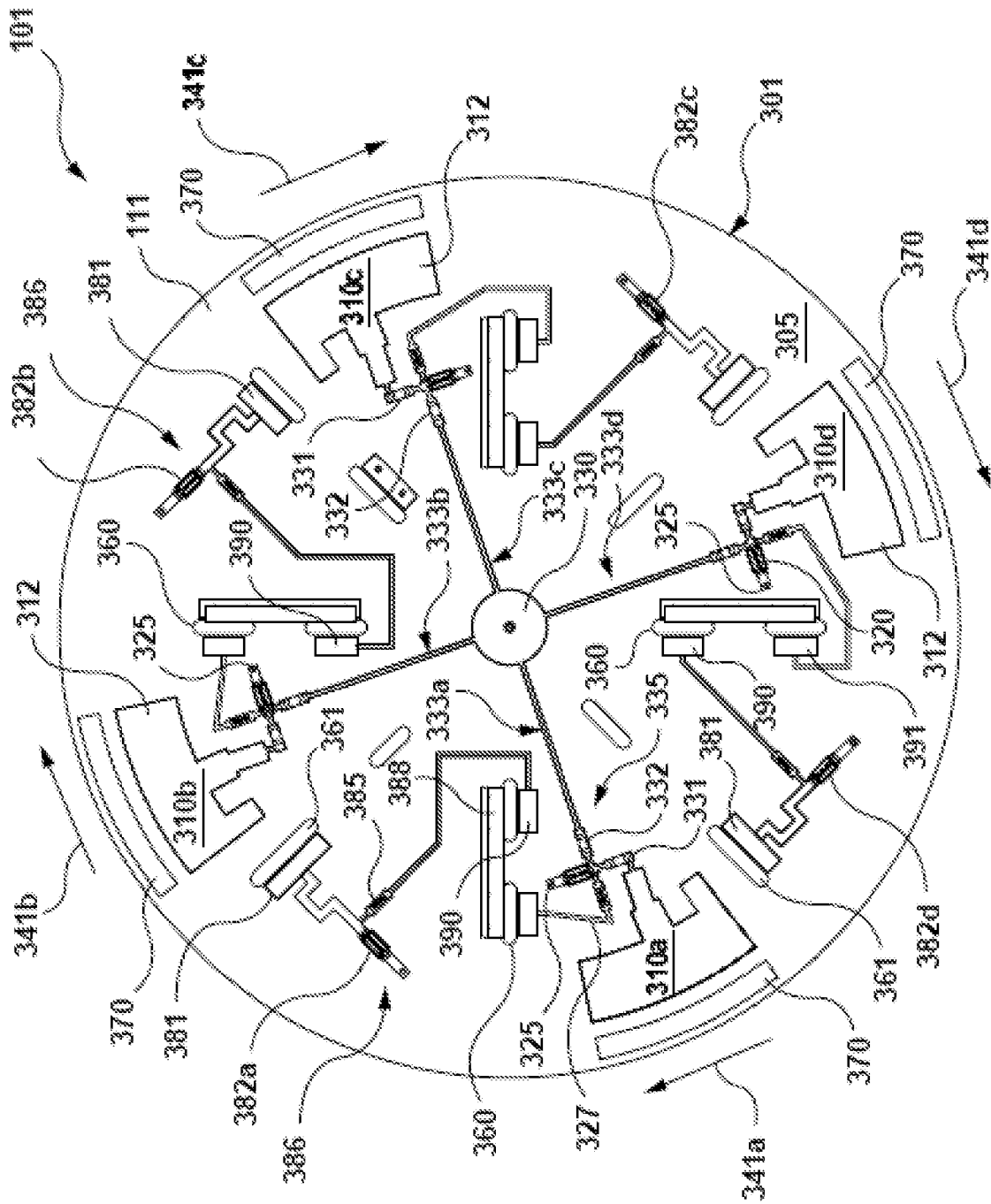

FIG. 3A

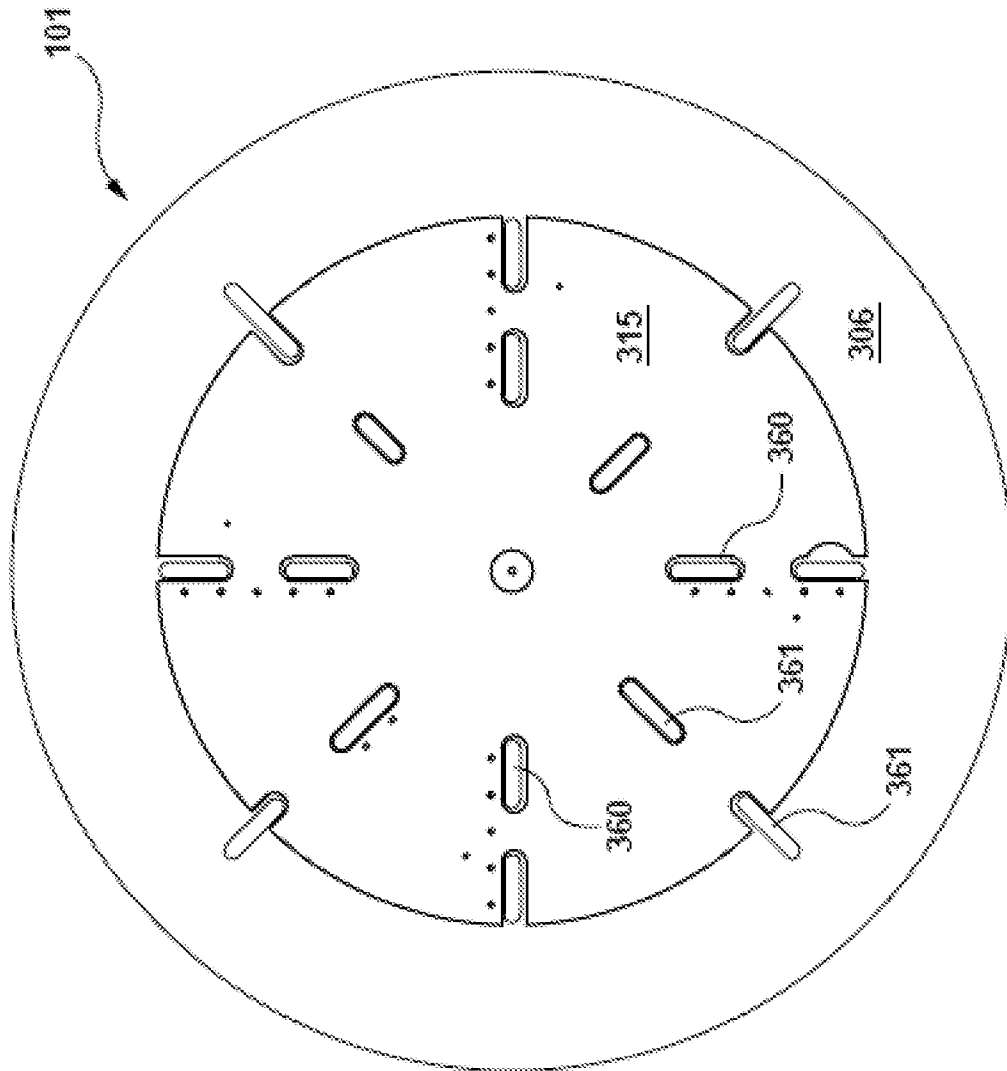

FIG. 3B

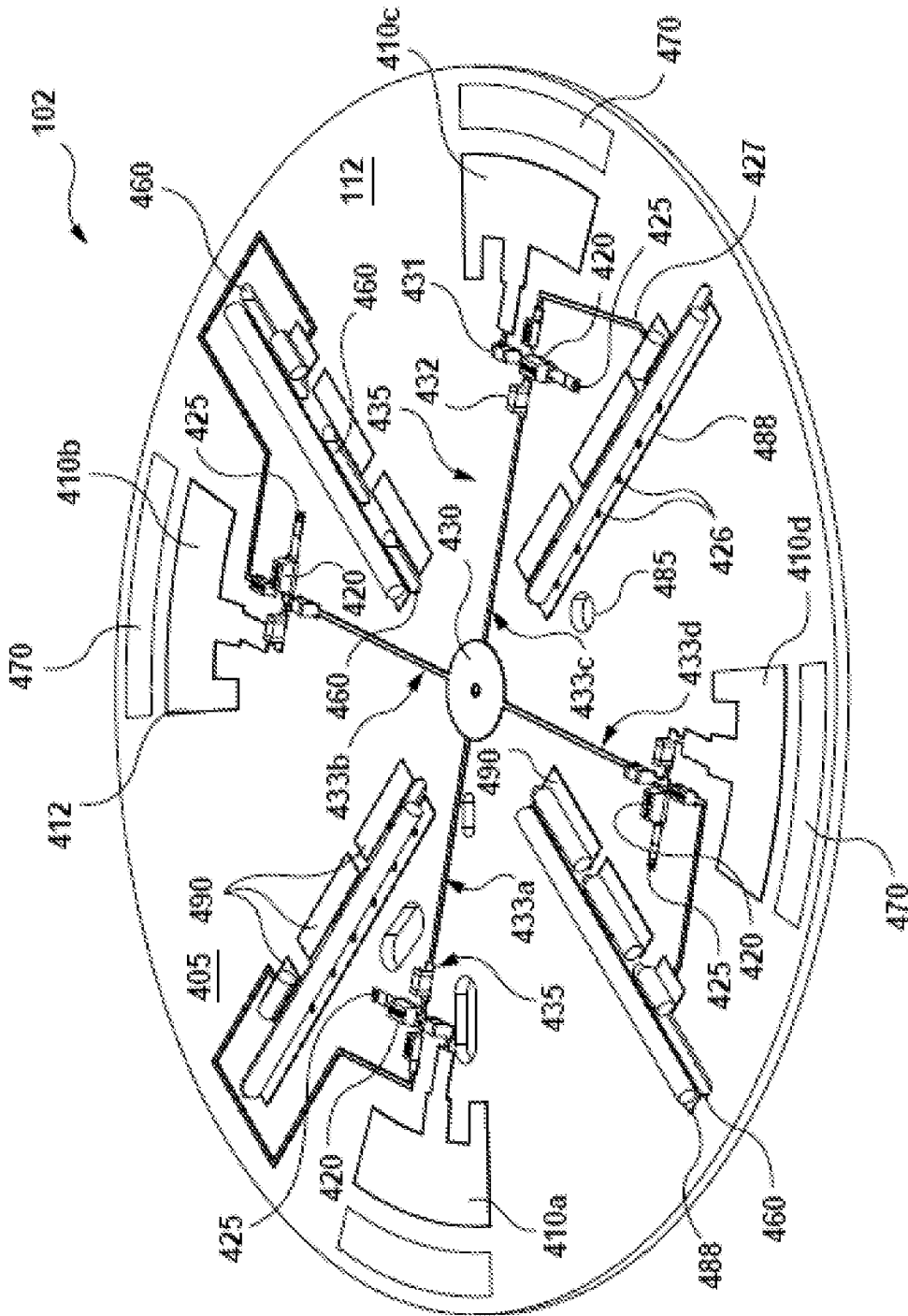

FIG. 4A

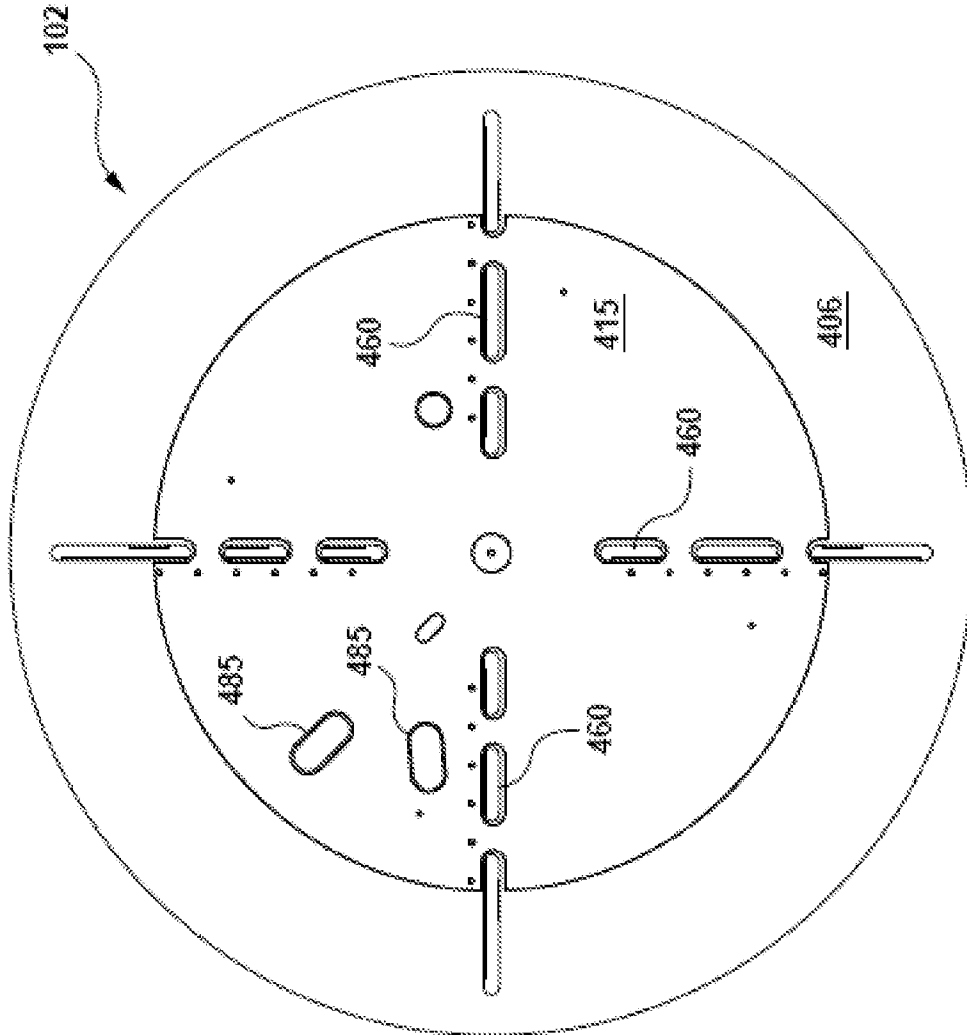

FIG. 4B

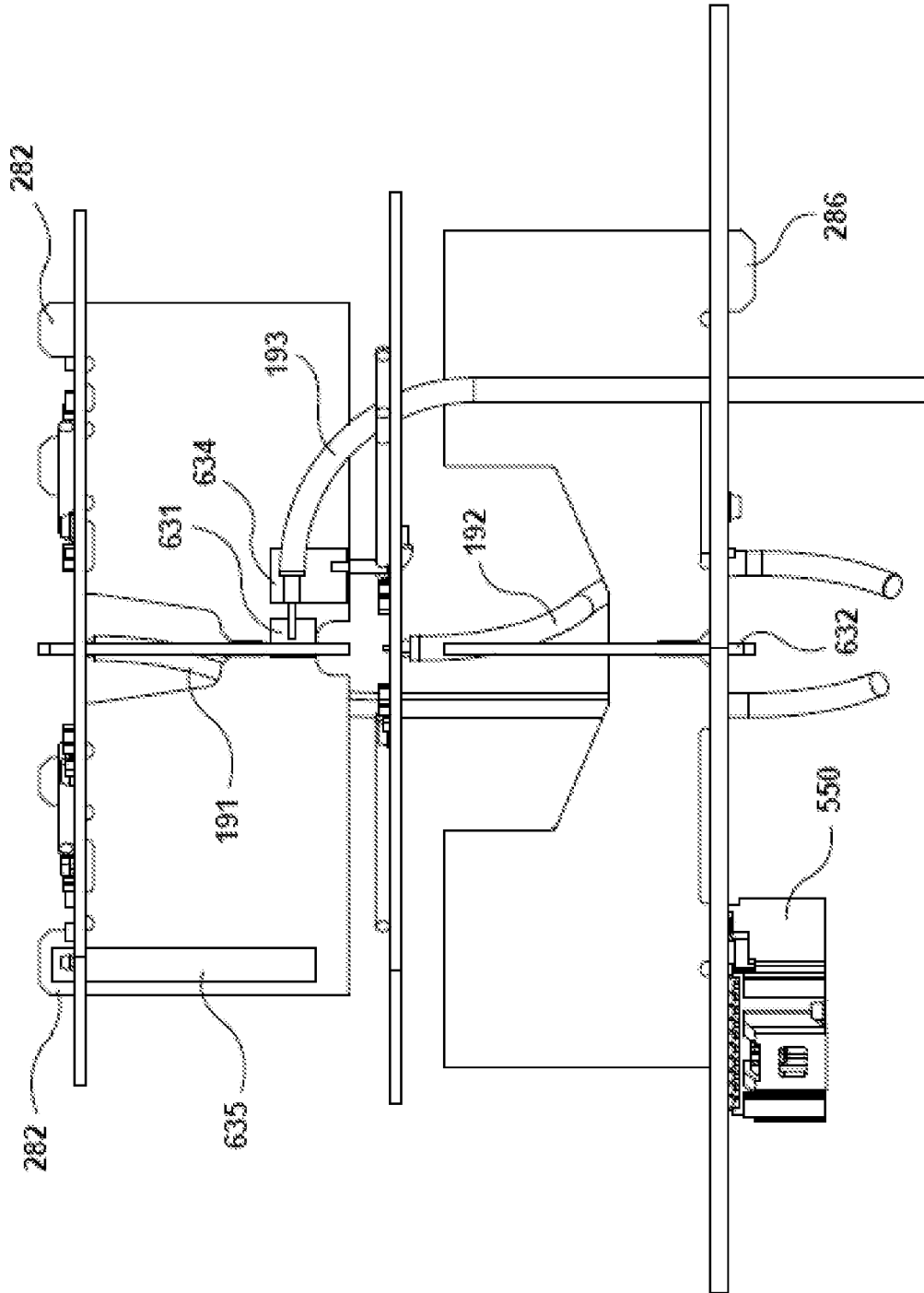

FIG. 6B

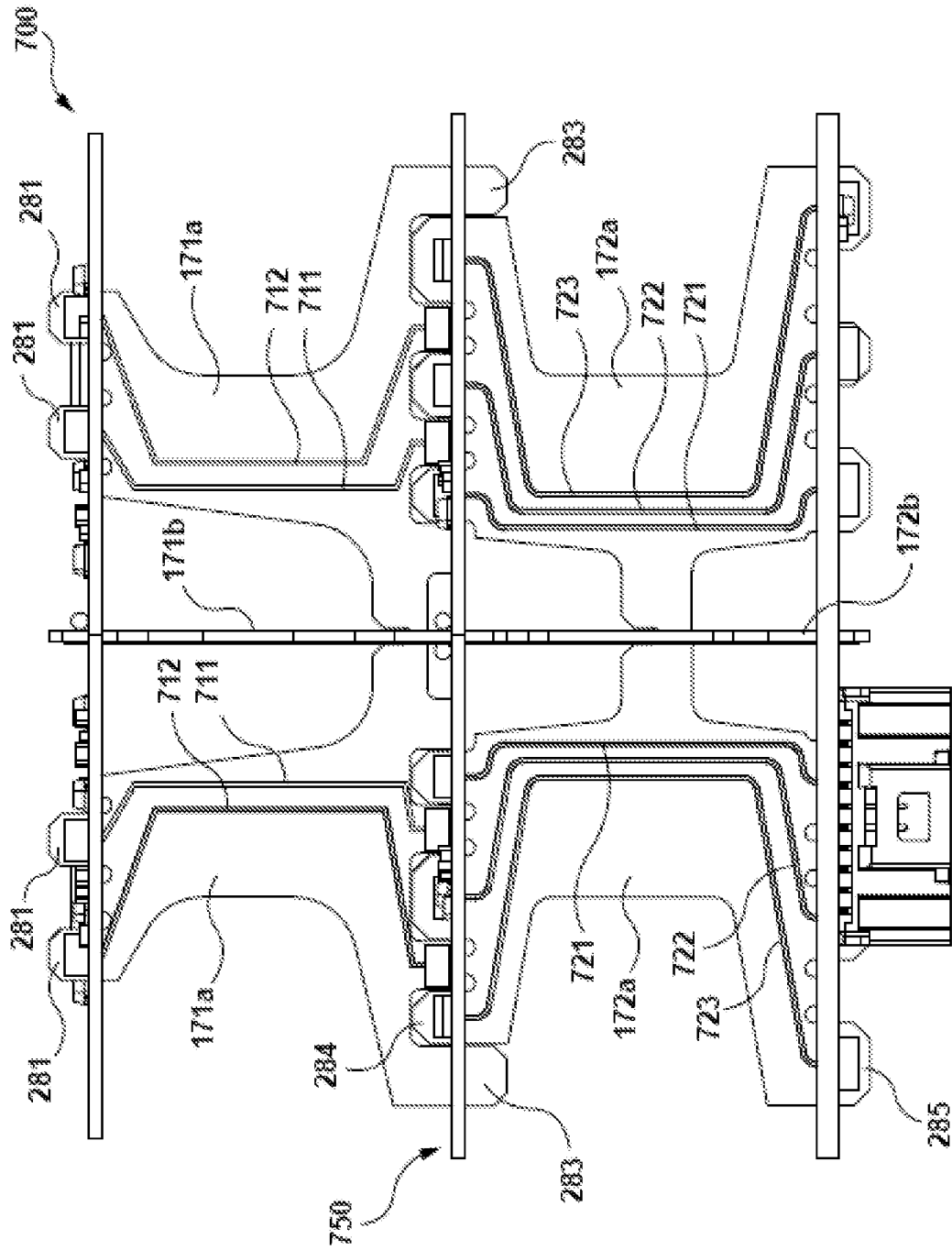

FIG. 7A

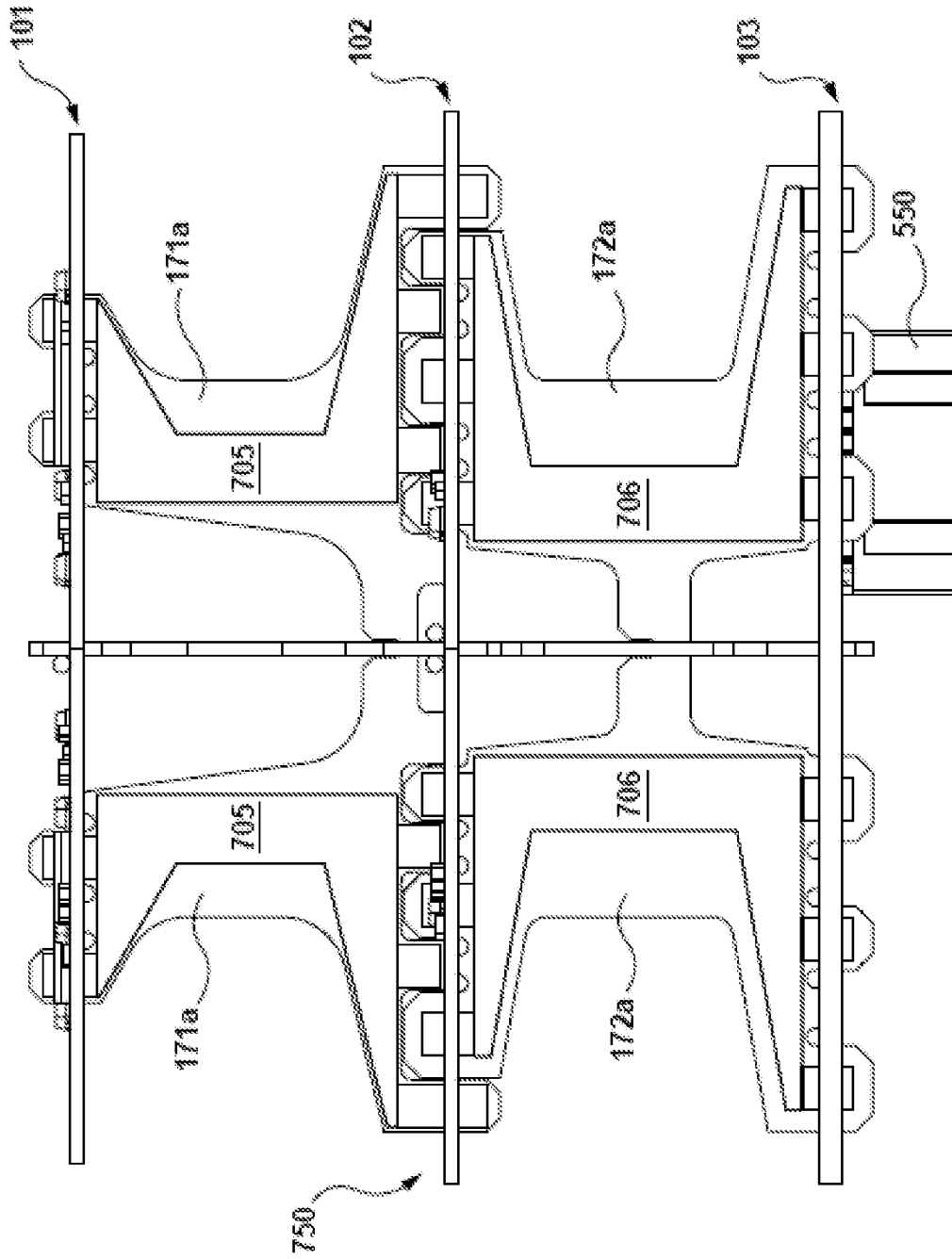
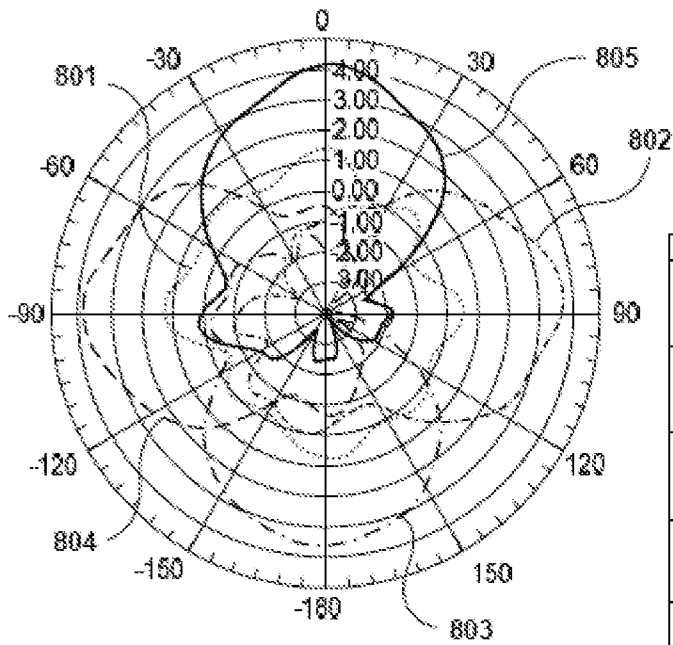

FIG. 7B



Curve Info			
— dBGainTheta			
5G_Setup; Last Adaptive	4.2208	-4.1248	-0.5477
Freq=5.5GHz; Theta=75deg			
----- dBGainTheta_1			
Imported	3.7982	-3.0721	-0.0042
Freq=5.5GHz; Theta=75deg			
- - - dBGainTheta_2			
Imported	3.7728	-2.8289	-0.2635
Freq=5.5GHz; Theta=75deg			
- - - dBGainTheta_3			
Imported	3.5475	-5.1500	-0.0084
Freq=5.5GHz; Theta=75deg			
..... dBGainTheta_4			
Imported	1.4138	-0.7830	-0.0413
Freq=5.5GHz; Theta=75deg			

FIG. 8A

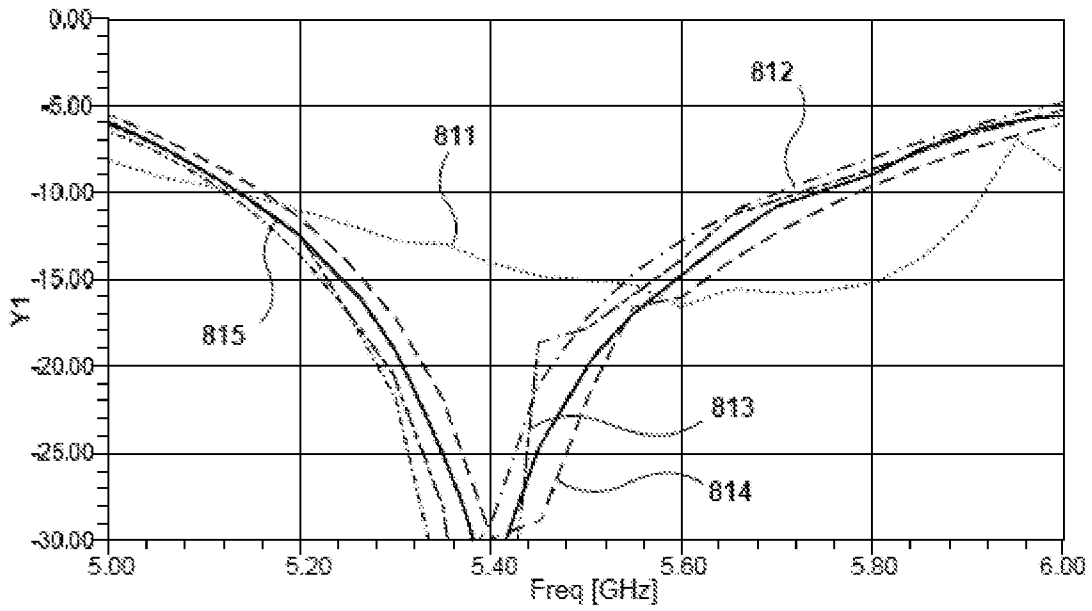
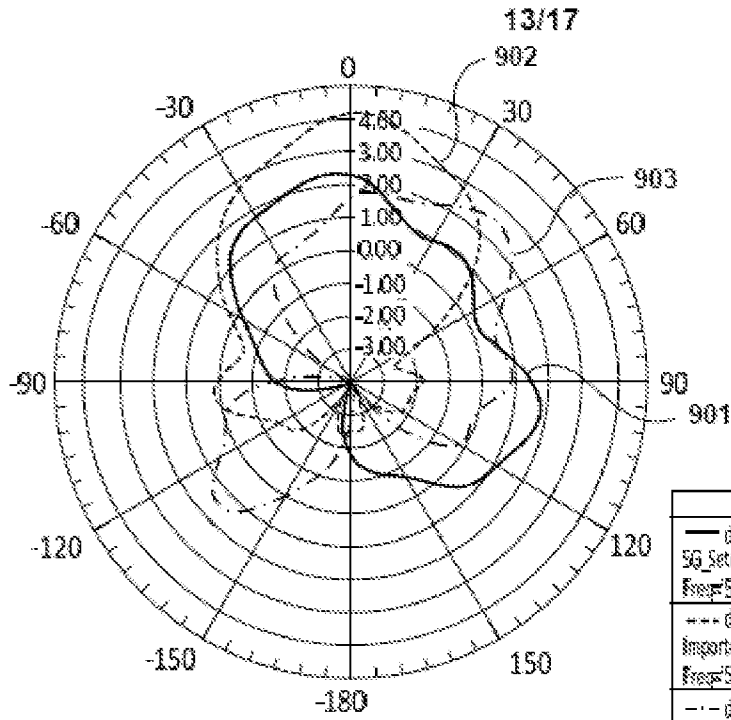

FIG. 8B



Curve Info			
— dBGainTheta1 5G_Setup: LastAdaptive Freq: 5.5GHz' Theta: 75deg'	23735	-43913	-42903
--- dBGainTheta_2 Imported Freq: 5.5GHz' Theta: 75deg'	42208	-41248	-45477
... dBGainTheta_3 Imported Freq: 5.5GHz' Theta: 75deg'	23548	-47235	-44485

FIG. 9A

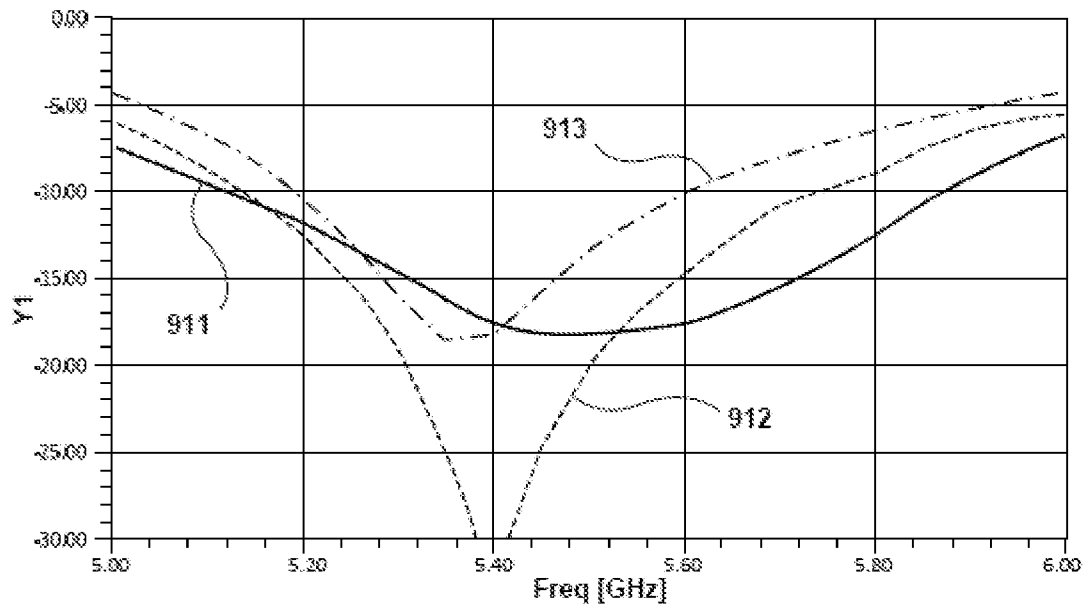

FIG. 9B

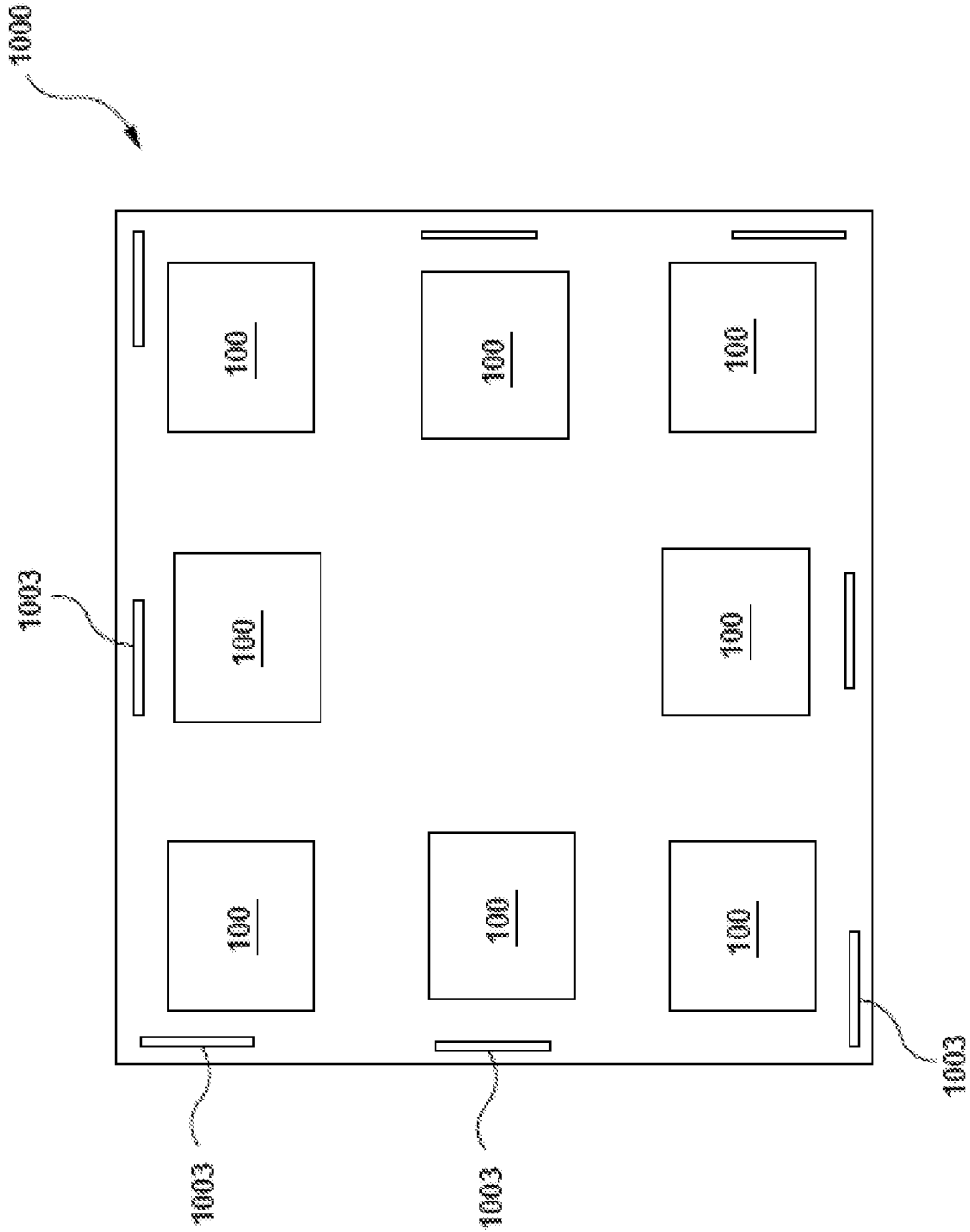

FIG. 10

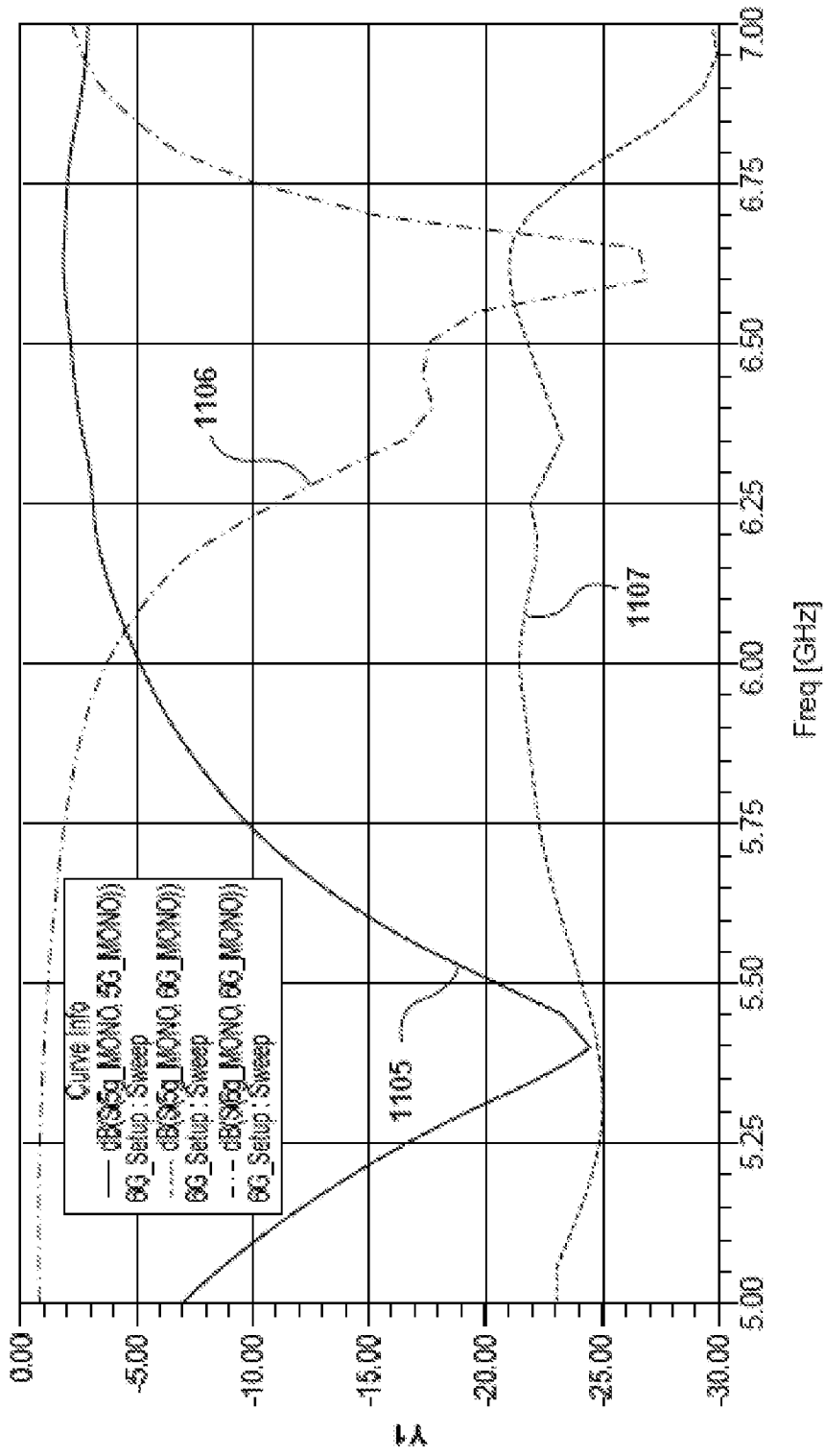

FIG. 11

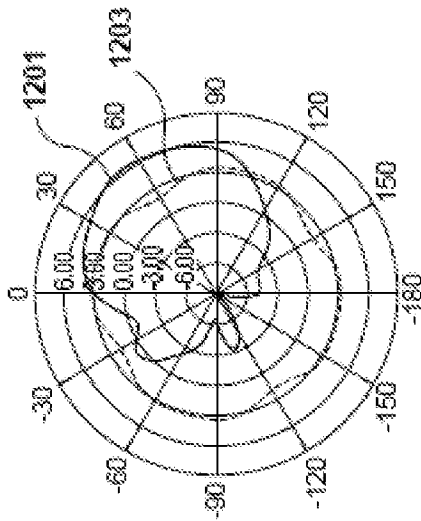

FIG. 12A

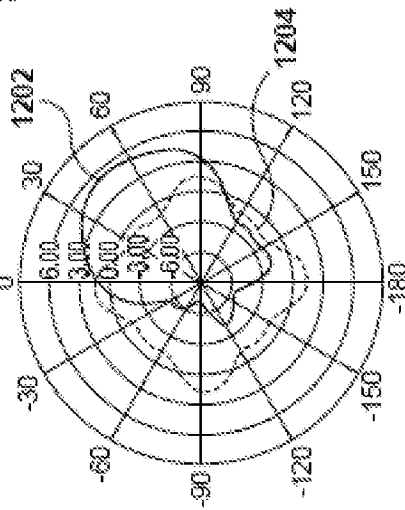

FIG. 12B

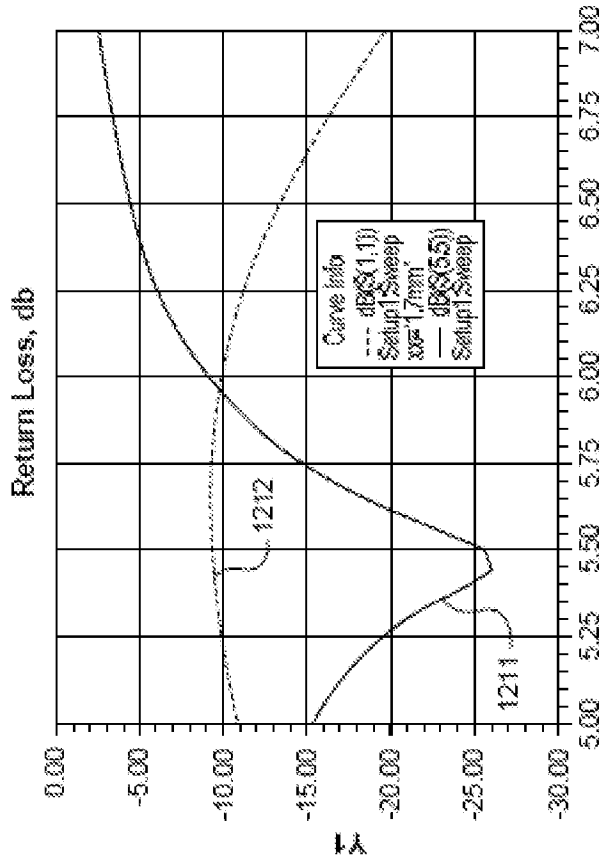

FIG. 12C

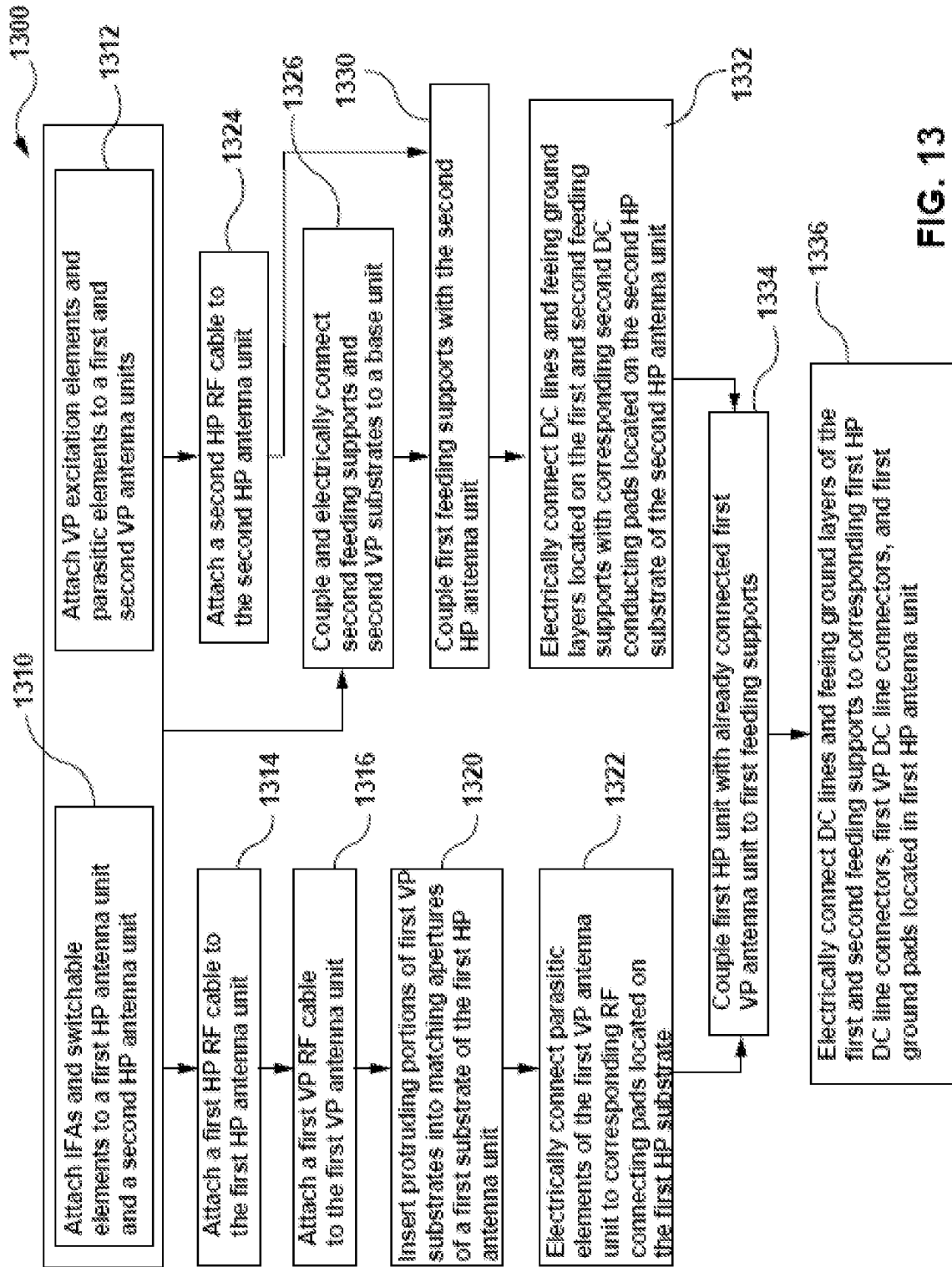

FIG. 13

INTERNATIONAL SEARCH REPORT

International application No.

PCT/CN2020/085684

A. CLASSIFICATION OF SUBJECT MATTER		
H01Q 21/24(2006.01)i		
According to International Patent Classification (IPC) or to both national classification and IPC		
B. FIELDS SEARCHED		
Minimum documentation searched (classification system followed by classification symbols)		
H01Q		
Documentation searched other than minimum documentation to the extent that such documents are included in the fields searched		
Electronic data base consulted during the international search (name of data base and, where practicable, search terms used)		
CNKI, CNPAT, EPODOC, WPI: antenna, array, polari????, horizontal, vertical, waveguide, parallel, VP, HP, IFA, PIFA, inverted F antenna, first,second		
C. DOCUMENTS CONSIDERED TO BE RELEVANT		
Category*	Citation of document, with indication, where appropriate, of the relevant passages	Relevant to claim No.
X	CN 106848530 A (SOUTHEAST UNIVERSITY et al.) 13 June 2017 (2017-06-13) description, paragraphs [0051]-[0060], figures 1-6	1-24
A	CN 106450797 A (WISTRON NEWEB CORPORATION) 22 February 2017 (2017-02-22) the whole document	1-24
A	CN 104143700 A (CHINA TELECOMMUNICATION CO., LTD.) 12 November 2014 (2014-11-12) the whole document	1-24
A	US 2017194718 A1 (LHC2 INC) 06 July 2017 (2017-07-06) the whole document	1-24
A	US 7310066 B1 (WIESON TECHNOLOGIES CO., LTD. et al.) 18 December 2007 (2007-12-18) the whole document	1-24
<input type="checkbox"/> Further documents are listed in the continuation of Box C. <input checked="" type="checkbox"/> See patent family annex.		
* Special categories of cited documents: "A" document defining the general state of the art which is not considered to be of particular relevance "E" earlier application or patent but published on or after the international filing date "L" document which may throw doubts on priority claim(s) or which is cited to establish the publication date of another citation or other special reason (as specified) "O" document referring to an oral disclosure, use, exhibition or other means "P" document published prior to the international filing date but later than the priority date claimed "T" later document published after the international filing date or priority date and not in conflict with the application but cited to understand the principle or theory underlying the invention "X" document of particular relevance; the claimed invention cannot be considered novel or cannot be considered to involve an inventive step when the document is taken alone "Y" document of particular relevance; the claimed invention cannot be considered to involve an inventive step when the document is combined with one or more other such documents, such combination being obvious to a person skilled in the art "&" document member of the same patent family		
Date of the actual completion of the international search		Date of mailing of the international search report
02 July 2020		21 July 2020
Name and mailing address of the ISA/CN		Authorized officer
National Intellectual Property Administration, PRC 6, Xitucheng Rd., Jimen Bridge, Haidian District, Beijing 100088 China		PAN,Xiaodan
Facsimile No. (86-10)62019451		Telephone No. 86-(10)-53961796

INTERNATIONAL SEARCH REPORT
Information on patent family members

International application No.

PCT/CN2020/085684

Patent document cited in search report			Publication date (day/month/year)	Patent family member(s)			Publication date (day/month/year)
CN	106848530	A	13 June 2017	CN	206893782	U	16 January 2018
CN	106450797	A	22 February 2017	None			
CN	104143700	A	12 November 2014	None			
US	2017194718	A1	06 July 2017	None			
US	7310066	B1	18 December 2007	TW	200814429	A	16 March 2008