



- (51) **International Patent Classification:**
F41H 1/02 (2006.01) B32B 27/02 (2006.01)
- (71) **International Application Number:**
PCT/US2013/076831
- (22) **International Filing Date:**
20 December 2013 (20.12.2013)
- (25) **Filing Language:** English
- (26) **Publication Language:** English
- (30) **Priority Data:**
61/739,966 20 December 2012 (20.12.2012) US
- (71) **Applicant:** WARWICK MILLS, INC. [US/US]; 301 Turnpike Road, PO Box 409, New Ipswich, New Hampshire 03071 (US).
- (72) **Inventor:** GRAY, Matthew C.; 35 Elmi Drive, Rindge, New Hampshire 03461 (US).
- (74) **Agents:** BURUM, Douglas P et al.; Maine Cernota & Rardin, 547 Amherst St., 3rd Floor, Nashua, New Hampshire 03063 (US).
- (81) **Designated States** (unless otherwise indicated, for every kind of national protection available): AE, AG, AL, AM, AO, AT, AU, AZ, BA, BB, BG, BH, BN, BR, BW, BY,

BZ, CA, CH, CL, CN, CO, CR, CU, CZ, DE, DK, DM, DO, DZ, EC, EE, EG, ES, FI, GB, GD, GE, GH, GM, GT, HN, HR, HU, ID, IL, IN, IR, IS, JP, KE, KG, KN, KP, KR, KZ, LA, LC, LK, LR, LS, LT, LU, LY, MA, MD, ME, MG, MK, MN, MW, MX, MY, MZ, NA, NG, NI, NO, NZ, OM, PA, PE, PG, PH, PL, PT, QA, RO, RS, RU, RW, SA, SC, SD, SE, SG, SK, SL, SM, ST, SV, SY, TH, TJ, TM, TN, TR, TT, TZ, UA, UG, US, UZ, VC, VN, ZA, ZM, ZW.

(84) **Designated States** (unless otherwise indicated, for every kind of regional protection available): ARIPO (BW, GH, GM, KE, LR, LS, MW, MZ, NA, RW, SD, SL, SZ, TZ, UG, ZM, ZW), Eurasian (AM, AZ, BY, KG, KZ, RU, TJ, TM), European (AL, AT, BE, BG, CH, CY, CZ, DE, DK, EE, ES, FI, FR, GB, GR, HR, HU, IE, IS, IT, LT, LU, LV, MC, MK, MT, NL, NO, PL, PT, RO, RS, SE, SI, SK, SM, TR), OAPI (BF, BJ, CF, CG, CI, CM, GA, GN, GQ, GW, KM, ML, MR, NE, SN, TD, TG).

Declarations under Rule 4.17:

— of inventorship (Rule 4.17(iv))

Published:

— with international search report (Art. 21(3))

(54) **Title:** MULTI-LAYER SOLID ELEMENT MOSAIC BODY ARMOR FOR ON-AXIS AND OFF-AXIS THREATS

The threat and failures modes are explained in terms of a gap between the solid elements (MSE to MSE) or the offset between the solid elements (MSE to TSE)

Figure 5B

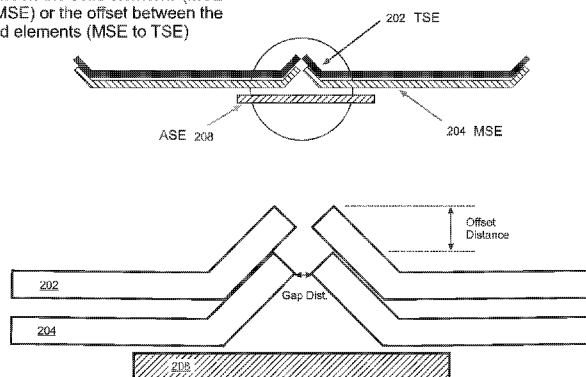

(57) **Abstract:** A flexible mosaic armor system that defeats threats at any attack angle includes top and middle solid elements layers separated by uniform gaps that intersect at apexes. The top elements can have a "hem" shape with raised edges. The middle elements can be flat, or can also have a hem shape. In embodiments, the edges of the top and middle layers are aligned and separated by an offset that is three or four times the gap width. Off-axis spike and needle strikes are thereby trapped between the two solid element layers, without added textile reinforcement. Embodiments include an apex layer of solid elements that overlap the first layer apexes, the apex layer being the second layer or a third layer beneath the 2 upper layers. The apex layer can be sandwiched between two textile backer layers that provide a full uninterrupted bonding surface to all of the solid element layers.

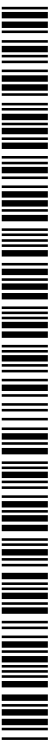

MULTI-LAYER SOLID ELEMENT MOSAIC BODY ARMOR FOR ON-AXIS
AND OFF-AXIS THREATS

RELATED APPLICATIONS

[0001] This application claims the benefit of U.S. Provisional Application No. 61/739,966, filed December 20, 2012, which is herein incorporated by reference in its entirety for all purposes.

FIELD OF THE INVENTION

[0002] The invention relates to body armor, and more particularly, to body armor that includes adjacent solid elements arranged in a mosaic pattern.

BACKGROUND OF THE INVENTION

[0003] Stab resistant body armor is typically constructed in one of two ways. One approach is to use a puncture resistant textile in a 15-30 ply layup to defeat spike threats. This approach however has limited capacity to stop higher energy attacks, and little or no performance for edged weapons.

[0004] Another approach is to use solid elements to protect against knife threats. A classic version of this approach is chain-mail, which has good performance on knives, but poor performance on spikes and no performance on needles. Another version is to use a mosaic pattern of adjacent or overlapping solid tiles or other solid elements. However, this approach typically remains vulnerable to stab attacks at junctures between the solid elements, especially at certain critical angles of attack.

[0005] The main source of weakness for many of these mosaic solid element systems is their flex points. Mosaic solutions such as those defined in patent

7,874,239 have nearly continuous protective coverage. Unlike chain-male ring systems that have broadly discontinuous coverage, because each ring is at least partly open, the mosaic system of patent 7,874,239 is not vulnerable to needle and spike attacks normal or up to approximately 20 degrees away from normal. However, with reference to the simplified example of Figure 1, at 45 degrees from normal the flex points in this mosaic solution can be defeated, for example by a spike as shown in Figure 1, which is able to cut through the crest of the hem on the solid element at 45 degrees and pass under the adjacent solid element, leaving the threat with enough energy to penetrate the remaining fabric layers. The same effect is seen at angles of 65 degrees from normal. This problem can be especially acute when a penetrator strikes an apex in the mosaic system, due to the enhanced flexibility of the apexes, where the apexes are the points where the gaps between solid elements meet each other.

[0006] Some combination solutions attempt to overcome the limitations of the textile and solid element approaches by combining both solid elements and textile layups in a single design. However, this approach has issues with cost, thickness, and flexibility.

[0007] What is needed, therefore, is a stab-resistant mosaic body armor that protects against knife, spike, and needle attacks at virtually all attack angles, including at apexes, while minimizing cost and thickness and maximizing flexibility.

SUMMARY OF THE INVENTION

[0008] The present invention is a flexible armor system that defeats both normal and off-axis threats at virtually any attack angle. The invention is a mosaic system comprising at least two X-Y layers of solid elements. The top layer is a substantially area-filling array of solid element separated by gaps having a uniform gap width. The gap width of the top layer is sufficiently small to stop penetrators at their limiting penetration distance. In some embodiments, the

second layer is a middle layer that is similar in construction to the top layer. In some of these embodiments the gaps of the top and middle layers are aligned, and the edges of the solid elements of the top level are offset in the Z-direction from the edges of the solid elements in the middle level. This configuration traps off-axis spike, knife, and needle strikes between the two layers of solid elements, and does not require added textile reinforcement.

[0009] In certain of these embodiments, the solid elements in at least one of the top and middle layers have a “hem” shape in which the bounding edges of the solid element is offset in the Z-direction from a central portion of the solid element, thereby creating a gap between the edges of the corresponding top and middle level solid elements even if the central portions of the top and middle solid elements are in direct contact. And in some of these embodiments the solid elements in both the top and middle layers have a “hem” shape.

[0010] In embodiments, a unique apex layer of solid elements is included, either as the second layer beneath the top layer, or as a third layer beneath the top and middle layers. The solid elements of the apex layer are positioned directly beneath the apexes of the top layer, which are the intersection points of the gaps of the top layer, so that the apex solid elements can stop any threat that attempts to penetrate the apexes of the top and middle layers. In some embodiments, the apex layer is sandwiched between two flexible textile backer layers, forming a backer sandwich that gives all the solid element layers a full, uninterrupted bonding surface to the flexible backer layer.

[0011] One general aspect of the present invention is a mosaic armor system for protection against a threat having a threat thickness at a failing penetration depth. The armor system includes a top layer of solid elements and a middle layer of solid elements, the solid elements in both layers being arranged in substantially space-filling X-Y arrays in which the solid elements are separated from each other by gaps that intersect at apexes, the gaps having a uniform gap width that is between 5% and 20% of the threat thickness at the failing penetration depth, the

middle layer being offset from the top layer by an offset that is at least three times larger than the gap width, a front face of the middle layer being adhered to a back face of the top layer and fibrous top and bottom covering layers arranged so as to sandwich the two layers of solid elements there between.

[0012] In embodiments, the top fibrous covering layer is adhered to a front face of the top layer of solid elements.

[0013] In some embodiments, the top fibrous covering layer has a recoverable stretch of greater than 30% at less than 20 pounds per inch of load as measured by ASTM method D6614 or D2594. In other embodiments, the bottom fibrous covering layer has elongation at break of less than 20%.

[0014] Various embodiments further include an intermediate fibrous layer located between the top layer of solid elements and the middle layer of solid elements.6. The mosaic armor system of claim 1, wherein all of the solid elements included in the top and middle layers are made of a material having an Rc hardness of at least 35.

[0015] In certain embodiments, the solid elements of the top and middle layers substantially share the same outline and are aligned with each other. In other embodiments the offset between the top and middle layers of solid elements is at least four times as large as the first gap size.

[0016] Various embodiments further include an apex XY layer of solid elements having a front side adhered to a back side of the first fibrous backing layer, the apex solid elements being located directly behind the apexes of the top layer of solid elements. Some of these embodiments further include a fibrous backing layer adhered to a back side of the apex layer, so that the apex solid elements are sandwiched between the fibrous bottom covering layer and the fibrous apex backing layer. And in some of these embodiments the fibrous apex backing layer has elongation at break of less than 20%.

[0017] Various embodiments that include an apex XY layer of solid elements further include up to 4 fibrous backing layers behind the apex solid element layer. In other of these embodiments the apex solid elements have a largest dimension of greater than 0.2 inches. And in still other of these embodiments all of the solid elements included in the apex layer are made of a material having an Rc hardness of at least 35.

[0018] In embodiments, the armor system defeats both edged blade and spike threats at 45 degrees at energies up to 24 Joules with less than 7mm of penetration, and at 0 degrees at energies up to 36 Joules with less than 20mm of penetration.

[0019] In some embodiments, a thickness of the solid elements of the middle layer is between 35% and 250% of a thickness of the solid elements of the top layer.

[0020] In other embodiments the front face of the middle layer is adhered to the back face of the top layer by a first adhesive that includes a neoprene elastomer.

[0021] In various embodiments the top and middle layers of solid elements are attached to each other by an attachment having at least 10 lbf of shear strength per square inch.

[0022] In certain embodiments the fibrous bottom covering layer is attached to the middle layer of solid elements by an attachment having greater than 10 lbf of shear strength per square inch. And some embodiments further include at least one adhesive layer that includes a neoprene elastomer.

[0023] Another general aspect of the present invention is a mosaic armor system that includes a top layer of solid elements and a middle layer of solid elements, the solid elements in both layers being arranged in substantially space-filling X-Y arrays in which the solid elements are separated from each other by gaps that intersect at apexes, the solid elements of the top and middle layers substantially

sharing the same outline and being aligned with each other, the solid elements of the top layer having edges that are offset in the Z direction from edges of the solid elements in the middle layer by an offset that is greater than a thickness of the top layer solid elements or a thickness of the middle layer solid elements, a front face of the middle layer being adhered to a back face of the top layer, and an apex XY layer of solid elements located directly behind the apexes of the top and middle layers of solid elements.

[0024] In embodiments, a thickness of the solid elements of the middle layer is between 35% and 250% of a thickness of the solid elements of the top layer.

[0025] Various embodiments further include fibrous top and bottom covering layers arranged so as to sandwich the top and middle layers of solid elements there between. In some of these embodiments, the fibrous top covering layer has a recoverable stretch of greater than 30% at less than 20 pounds per inch of load as measured by ASTM method D6614 or D2594. In other of these embodiments, the fibrous bottom covering layer has elongation at break of less than 20%. And in still other of these embodiments, the fibrous bottom covering layer is attached to the middle layer of solid elements by an attachment having greater than 10 lbf of shear strength per square inch.

[0026] Certain embodiments further include an intermediate fibrous layer located between the top layer of solid elements and the middle layer of solid elements. In some embodiments the top and middle layers of solid elements are attached to each other by an attachment having at least 10 lbf of shear strength per square inch. In other embodiments, all of the solid elements included in the top and middle layers are made of a material having an Rc hardness of at least 35.

[0027] In certain embodiments all of the solid elements included in the apex layers are made of a material having an Rc hardness of at least 35.

[0028] In various embodiments the armor system defeats both edged blade and spike threats at both 0 degrees and 65 degrees at energies up to 15 Joules with less

than 10mm of penetration, and at energies up to 25 Joules with less than 20mm of penetration.

[0029] In some embodiments an offset between the top and middle layers of solid elements is greater than or equal to the gap between the solid elements in each of the top and middle layers. In other embodiments an offset between the top and middle layers of solid elements is greater than or equal to the thickness of the top layer of solid elements or the middle layer of solid elements.

[0030] Embodiments further include fibrous top and bottom covering layers arranged so as to sandwich the top and middle layers of solid elements there between, and a fibrous backing layer adhered to a back side of the apex layer, so that the apex solid elements are sandwiched between the fibrous bottom covering layer and the fibrous backing layer.

[0031] In some embodiments the fibrous backing layer has elongation at break of less than 20%. Other embodiments further include up to 4 fibrous backing layers adhered to a back side of the apex solid element layer.

[0032] In various embodiments the apex solid elements have a largest dimension that is greater than 0.2 inches. And in certain embodiments the front face of the middle layer is adhered to the back face of the top layer by a first adhesive that includes a neoprene elastomer.

[0033] Yet another general aspect of the present invention is a mosaic armor system that includes a top layer of solid elements and a middle layer of solid elements, the solid elements in both layers being arranged in substantially space-filling X-Y arrays in which the solid elements are separated from each other by gaps that intersect at apexes, the solid elements of the top and middle layers substantially sharing the same outline and being aligned with each other. The mosaic armor further includes fibrous top and bottom covering layers arranged so as to sandwich the two layers of solid elements there between, the fibrous top covering layer having a recoverable stretch of greater than 30% at less than 20

pounds per inch of load as measured by ASTM method D6614 or D2594, the fibrous bottom covering layer having elongation at break of less than 20%.

[0034] In embodiments, the top and middle layers of solid elements are attached to each other by an attachment having at least 10 lbf per square inch of shear strength. In some embodiments, the fibrous bottom covering layer is attached to the middle layer of solid elements by an attachment having greater than 10 lbf of shear strength per square inch. In other embodiments, all of the solid elements included in the top layer are made of a material having an Rc hardness of at least 35.

[0035] Various embodiments further include an intermediate fibrous layer located between the top layer of solid elements and the middle layer of solid elements.

[0036] Certain embodiments further include an apex XY layer of solid elements located directly behind the apexes of the top and middle layers of solid elements. Some of these embodiments further include a fibrous backing layer adhered to a back side of the apex layer, so that the apex solid elements are sandwiched between the fibrous bottom covering layer and the fibrous backing layer. Other of these embodiments further include up to 4 fibrous backing layers adhered to a back side of the apex layer, so that the apex solid elements are sandwiched between the fibrous bottom covering layer and the two fibrous backing layers. And in some of these embodiments at least one of the fibrous backing layers has elongation at break of less than 20%.

[0037] In various embodiments that include an apex XY layer of solid elements, the apex solid elements have a largest dimension of greater than 0.2 inches. And in certain embodiments all of the solid elements included in the apex layers are made of a material having an Rc hardness of at least 35.

[0038] Still another general aspect of the present invention is a mosaic armor system that includes a top layer of solid elements and a middle layer of solid

elements, the solid elements in both layers being arranged in substantially space-filling X-Y arrays in which the solid elements are separated from each other by gaps that intersect at apexes, the solid elements of the top and middle layers substantially sharing the same outline and being aligned with each other, an apex XY layer of solid elements located directly behind the apexes of the top and middle layers of solid elements, a fibrous bottom covering layer arranged between the middle layer of solid elements and the apex layer of solid elements, the fibrous bottom covering layer having elongation at break of less than 20%, and a fibrous backing layer adhered to a back side of the apex layer, so that the apex solid elements are sandwiched between the fibrous bottom covering layer and the fibrous backing layer.

[0039] In embodiments, all of the solid elements included in the top and middle layers are made of a material having an Rc hardness of at least 35. In some embodiments all of the solid elements included in the apex layers are made of a material having an Rc hardness of at least 35.

[0040] Various embodiments further include an additional fibrous backing layer adhered to a back side of the apex layer, so that the apex solid elements are sandwiched between the fibrous bottom covering layer and the two fibrous backing layers. And in some of these embodiments at least one of the fibrous backing layers has elongation at break of less than 20%.

[0041] In certain embodiments the top and middle layers of solid elements are attached to each other by an attachment having at least 10 lbf of shear strength per square inch.

[0042] Embodiments further include an intermediate fibrous layer located between the top layer of solid elements and the middle layer of solid elements. in some embodiments the fibrous bottom covering layer is attached to the middle layer of solid elements by an attachment having greater than 10 lbf of shear

strength per square inch. And in various embodiments the apex solid elements have a largest dimension of greater than 0.2 inches.

[0043] The features and advantages described herein are not all-inclusive and, in particular, many additional features and advantages will be apparent to one of ordinary skill in the art in view of the drawings, specification, and claims. Moreover, it should be noted that the language used in the specification has been principally selected for readability and instructional purposes, and not to limit the scope of the inventive subject matter.

BRIEF DESCRIPTION OF THE DRAWINGS

[0044] Figure 1 is a side view illustration of penetration of a prior art armor system by a spike applied at a 45 degree angle to a joint between solid elements;

[0045] Figure 2A is a cross-sectional illustration of the layers of an embodiment of the present invention that includes a top layer of solid elements, a middle layer of solid elements, and an apex layer of solid elements;

[0046] Figure 2B is a cross-sectional illustration of the layers of an embodiment of the present invention that includes a top layer of solid elements and an apex layer of solid elements, without including a middle layer of solid elements;

[0047] Figure 2C is a cross-sectional illustration of the layers of an embodiment similar to Figure 2A, but including fibrous layers only between the top layer of solid elements and the apex layer of solid elements, and behind the apex layer of solid elements, without including a fibrous layer on top of the top layer of solid elements;

[0048] Figure 2D is a cross-sectional illustration of the layers of an embodiment similar to Figure 2B, but including four low elongation fibrous backer layers behind the apex layer 208 of solid elements;

[0049] Figure 2E is a cross-sectional illustration of the layers of an embodiment similar to Figure 2A, but including an additional fibrous intermediate layer between the top layer of solid elements and the middle layer of solid elements;

[0050] Figure 3A is a side view of an embodiment of the present invention where the top solid elements are hem-shaped and the middle solid elements are flat;

[0051] Figure 3B is a side view of an embodiment of the present invention where both the top solid elements and the middle solid elements are hem-shaped;

[0052] Figure 4 is a cross-sectional view of an embodiment showing specific threat and embodiment dimensions;

[0053] Figure 5A is a cross-sectional view of an embodiment in which the top layer has a hem shape and the middle layer is flat, including an enlargement comparing the offset distance with the gap size;

[0054] Figure 5B is a cross-sectional view of an embodiment in which both the top and middle layers have a hem shape, including an enlargement comparing the offset distance with the gap size;

[0055] Figures 6A-6C are series of cross-sectional side views showing penetrators attempting to penetrate embodiments similar to Figure 5 with an attack angle of 45 degrees, where in Figure 6A the offset between the MSE layer and the TSE layer is less than 3 times the gap between the MSE's, the offset in Figure 6B between the MSE layer and the TSE layer is 5 times the gap between the MSE's, and in Figure 6C the offset between the MSE layer and the TSE layer is greater than 5 times the gap between the MSE's;

[0056] Figures 7A and 7B are side views of embodiments having hem-shaped TSE's and flat MSE's, illustrating the offset of the edges when the central portions are in contact;

[0057] Figure 8A is a perspective view from above of a pair of triangular TSE and MSE solid elements, where the TSE element has a “hem” shape and the corresponding MSE element is flat;

[0058] Figure 8B is a perspective view from above of a pair of triangular TSE and MSE solid elements, where both the TSE element and the MSE elements have a “hem” shape;

[0059] Figure 9A is a perspective view from above of three pairs of elements similar to Figure 8A, shown together;

[0060] Figure 9B is a perspective view from above of three pairs of elements similar to Figure 8B, shown together;

[0061] Figure 10 is a view of the pairs of Figure 9B shown from directly above; and

[0062] Figure 11 is a view of the pairs of Figure 9B shown from directly below.

DETAILED DESCRIPTION

[0063] The present invention is a flexible armor system that defeats both normal and off-axis threats at virtually any attack angle. With reference to Figure 2A, the invention is a mosaic system comprising at least 2 layers of solid elements 202, 204. The top layer 202 is a substantially area-filling array of solid elements 202 separated by gaps having a uniform gap width. The gap width of the top layer is sufficiently small to stop penetrators at their limiting penetration distance. In certain embodiments, the gap between the solid elements 202 of the top layer is between 7% and 15% of a threat width at the limiting penetration distance.

[0064] In the embodiment of Figure 2A, the second layer is a middle layer 204 that is also a substantially area-filling array of solid elements separated by gaps having a uniform width. In some embodiments, the gaps of the top and middle layers are aligned in the Z-direction so that the two upper layers of solid elements

202, 204 substantially share a common outline in the x-y plane, and there is a unique offset between the bounding edges of the corresponding solid elements in the top and middle layers. This configuration traps off-axis spike and needle strikes between the two layers of solid elements 202, 204, and does not require added textile reinforcement. In some of these embodiments, the offset between the edges of the corresponding top and middle solid elements in the two layers 202, 204 is greater than or equal to the thickness of the top layer solid elements 202. See also Figure 5B, described in more detail below.

[0065] In some embodiments, the top and middle layers 202, 204 are sandwiched between an upper fibrous layer 200 that has recoverable stretch of greater than 30% at less than 20 pounds per inch of load as measured by ASTM method D6614 or D2594, where materials that meet this requirement are referred to herein as “low modulus” materials, and a lower fibrous layer 206 that has elongation at break of less than 20%, where materials that meet this requirement are referred to herein as “high modulus” materials.

[0066] In other embodiments, the top and middle layers 202, 204 are sandwiched between an upper fibrous layer 200 that has recoverable stretch of greater than 30% at less than 20 pounds per inch of load as measured by ASTM method D6614 or D2594, and a lower fibrous layer 206 that has elongation at break of less than 20%.

[0067] The embodiment of Figure 2A further includes a unique apex solid element layer 208 beneath the other 2 layers 202, 204. The solid elements of the apex layer 208 are positioned directly beneath the apexes of the top layer 202, which are the intersection points of the gaps of the top layer, so that the apex solid elements can stop any threat that attempts to pass through the apexes of the top and middle layers. In the embodiment of Figure 2A, this apex layer 208 is sandwiched between two flexible textile backer layers 206, 210, forming a backer “sandwich” that gives all the solid element layers a full uninterrupted bonding surface to the flexible backer layers.

[0068] In various embodiments, there is at least one flexible backer fibrous layer 206 between the apex solid element layer 208 and the first 2 solid element layers 202, 204 and at least one additional low elongation backer layer 210, 212 that sandwiches the apex layer 208 of solid elements.

[0069] In various embodiments, there is at least one flexible backer fibrous layer 206 between the apex solid element layer 208 and the first 2 solid element layers 202, 204 four additional low elongation backer layer 210, 212 that sandwiches the apex layer 208 of solid elements.

[0070] In some embodiments, the solid elements of the top, middle, and/or apex layers 202, 204, 208 are made of material of at least Rc hardness of > 35 . The solid elements ("SE's") can be adhered together between at least 2 fibrous covering layers. The offset between the edges of the top and middle layer solid elements can be greater than three times the gap size of the top layer, and in some embodiments greater than four times the gap size of the top layer.

[0071] In various embodiments, the middle layer is omitted. With reference to Figure 2B, in other general aspects of the present invention, the second layer is the apex layer 208, as described above, and the middle layer 204 of solid elements is omitted.

[0072] With reference to Figure 2C, some embodiments include fibrous layers only between the top layer of solid elements and the apex layer of solid elements, and behind the apex layer of solid elements, without including a fibrous layer on top of the top layer of solid elements.

[0073] With reference to Figure 2D, in certain embodiments there is at least one flexible fibrous backer layer 206 between the apex solid element layer 208 and the first solid element layer 202, and up to four low elongation backer layers behind the apex layer 208 of solid elements. In various embodiments, at least one of the backer layers is a high modulus layer, and in some embodiments, at least one of the backer layers is a low modulus layer.

[0074] And with reference to Figure 2E, some embodiments further include an intermediate fibrous layer 218 between the top layer of solid elements 202 and the middle layer of solid elements 204. The intermediate fibrous layer 218 can be of low modulus or high modulus.

[0075] Note that terms used herein are defined as follows:

[0076] A Solid Element (“SE”) apex is formed by the intersection of the corners of adjacent solid elements. In the case of triangular solid elements, 6 SE’s meet to form the apex. In the case of square solid elements, 4 SE’s meet to form the apex, and so on.

[0077] Solid Element types include

[0078] Apex Solid Elements (ASE’s)

[0079] Top Solid Elements (TSE’s) nearest the strike face

[0080] Middle Solid Elements (MSE’s) between the TSE and the ASE layers

[0081] The x-y plane is the surface of the fibrous layers

[0082] The z-direction is normal to the fibrous layers

[0083] Offsets are in the z direction

[0084] Gaps are in the x-y plan

[0085] The threat thickness is the measured thickness of a threat measured at the penetration limit in the smaller of its cross sectional dimensions.

[0086] When tested in accordance to ASTM D751 ADHESION OF COATING TO FABRIC, the stretch material of the upper fibrous cover layer 200 in various embodiments has at least 2 lb/in of peel strength when bonded to itself. In some embodiments, this upper layer 200 is made of a nylon lycra knit fabric with an 8

oz/yd² basis weight and 30-50% recoverable stretch at less than 10 pounds per inch, as measured by ASTM method D6614 or D2594 methods in both courses and wails. Stretch wovens and/or stretch non-wovens may also be used for the cover layer 200. In embodiments, the cover layer 200 has enough abrasion resistance to support the fielded life of the product. In certain embodiments, the cover layer 200 is a coated cover knit that has an elongation of 240% at an average load of 48 lbf when tested on a tensile testing machine at a rate of 12 in/min at 1 inch width and a 3 inch gauge length.

[0087] In embodiments, the backing layer 206 that is closest to the upper solid element layers 202, 204 is a coated woven of at least 15gpd. In some embodiments, when a one inch overlap of 2 pieces of the material is tested in shear force on a tensile testing machine at a rate of 12in/min, the bond between the material pieces has at least 300 lbf of shear strength. In certain embodiments, when tested on a tensile testing machine at a rate of 12 in/min at 1 inch width and a 3 in gauge length, the elongation at break is less than 20%, and in some embodiments it is less than 10%.

[0088] In various embodiments, the bond between the two upper solid element layers 202, 204 has at least 10 lbf per square inch of shear strength when tested in shear force on a tensile testing machine at a rate of 12in/min. In some embodiments, the adhesive is vulcanizing elastomer and is cured under pressure and elevated temperature. In certain embodiments, when the bond between these solid element layers 202, 204 and the backer material 206 is tested in shear force on a tensile testing machine at a rate of 12in/min, the bond between the material pieces has greater than 10 lbf per square inch of shear strength per square inch.

[0089] The woven fibrous backer layers 206, 210, 212 can be made from para aramid, LCP polyester, UHMWPE, nylon, polyester, or another fiber having greater than 4 gpd tenacity, and in some embodiments greater than 10gpd tenacity. The adhesive can be neoprene, SBR, Urethane, or another polymer or elastomer with greater than 50% elongation at break.

[0090] In various embodiments, each solid element is a coated metallic element with at least 1275 MPa of tensile strength and greater than 3% elongation. In some of these embodiments, the metal is work-hardened stainless steel, medium to high carbon steel, type 4 or type 5 titanium, or a high-hardness aluminum alloy. The TSE offset in embodiments is made by forming a continuous hem around the perimeter of the top layer solid element. In some embodiments, the hardness of the solid elements is at least equal to the hardness of the threats. However, this requirement does not apply to other embodiments, such as in the case of alloy aluminum where the hardness can be lower but the thickness of the solid elements must be higher than in steel or titanium.

[0091] Apex Solid Elements can be round, hexagonal or other shapes having the required dimensions. Top solid elements closest to strike face can be equilateral triangles that have a hem on all 3 sides to create the required offset distances between the edges of the upper and middle level solid elements. Middle solid elements can also be equilateral triangles made of flat material or with a lower or the same hem as the top solid elements to preserve the offset distance. Triangular and hexagonal configurations are preferred in some embodiments over squares or rectangles because these systems have added flex lines and flex along 3 axes rather than only 2.

[0092] A side view of an embodiment of the present invention is presented in Figure 3A. In this embodiment, the top solid elements or "TSE" 300 have raised edges, to create a "hem" shape, while the middle solid elements or "MSE" 302 are flat, and have a thickness of between 35% and 250%% of the TSE thickness. The TSE and MSE solid elements 300 are stacked on top of one another with their edges aligned, so that if a threat (such as the spike shown in the figure) strikes the hem of the TSE 300, and cuts through the crest of the hem, going under the adjacent TSE 300, it then comes in contact with the face of the MSE 302 below the adjacent TSE 300. Unable to penetrate the MSE 302, the threat (spike) begins

to bend, before coming to a stop between the top 202 and middle 204 solid element layers.

[0093] A side view of an embodiment of the present invention is presented in Figure 3B. In this embodiment, both the TSE elements 300 and the MSE elements 302 have raised edges, to create a “hem” shape. In various embodiments, the MSE elements 302 have a thickness of between 35% and 250% of the TSE thickness. The TSE and MSE solid elements 300 are stacked on top of one another with their edges aligned, so that if a threat (such as the spike shown in the figure) strikes the hem of the TSE 300, and cuts through the crest of the hem, going under the adjacent TSE 300, it then comes in contact with the face of the MSE 302 below the adjacent TSE 300. Unable to penetrate the MSE 302, the threat (spike) begins to bend, and being forced into the hem of the MSE and coming to a stop between the top 202 and middle 204 solid element layers. In some instances, the threat (spike) is forced out of the TSE layer.

[0094] The intersections or apexes of gaps between the solid elements in the embodiment of Figure 3 represent a weakness to penetration, due at least in part to the enhanced flexibility at the apexes. This is overcome in the embodiment of Figures 3A and 3B by placing the solid elements 304 of the ASE layer 208 behind the apexes of the TSE 202 and the MSE 204. In embodiments, the largest dimension of the ASE is 0.2-0.5". The larger the size of the ASE, the greater the protection area provided near the apex, and the more surface area provided for adhesion of the apex element, making it harder for the threat (spike) to penetrate or move the ASE out of position upon impact. The placement of the ASE between 2 backer layers 206, 210 provides a full adhesive bonding surface for the MSE 200 and the ASE 202 on the sandwiched backers 206, 210. By placing the ASE 308 between two backing layers 206, 210, the ASE 208 does not interfere with the bonding area of the MSE 204 layer, and vice versa.

[0095] With reference to Figure 4, in various embodiments the TSE 202, MSE 204, and ASE 208 elements have the dimensions shown. After a penetration of a

threat, the length of the threat beyond the panel is measured. The figure shows 2 adjacent MSE's 204 and a threat having a length of 5mm beyond the panel at 45 degrees.

[0096] A cross-sectional view of an embodiment similar to Figure 3A is presented in Figure 5A. Details of the relative offset size and gap distance are presented in the detailed enlargement. The threat and failure modes of the embodiment are explained in terms of the gap size 500 between the solid elements (e.g. MSE to MSE) and/or the offset distance 502 between the solid elements (MSE to TSE)

[0097] A cross-sectional view of an embodiment similar to Figure 3B is presented in Figure 5B. Details of the relative offset size and gap distance are presented in the detailed enlargement. The threat and failure modes of the embodiment are explained in terms of the gap size 500 between the solid elements (e.g. MSE to MSE) and/or the offset distance 502 between the solid elements (MSE to TSE).

[0098] Figures 6A through 6C illustrate the interaction between the gap size and the offset distance for embodiments similar to Figure 5A. When the offset between the edges of corresponding solid elements in the MSE layer and the TSE layer 204 is less than 3 times the gap between the MSE's 204, as shown in Figure 6A, the threat is able to push through all the SE's and into the ASE. However, when the offset between the MSE layer 204 and the TSE layer is 5 times the gap between the MSE's 204, the threat is forced to contact the MSE under the adjacent SE. And when the offset between the MSE layer 204 and the TSE layer is greater than 5 times the gap between the MSE's 202, as shown in Figure 6C, the threat is forced to contact the adjacent MSE 204.

[0099] With reference to Figures 7A and 7B, in some embodiments when the threat length after penetration is 5mm, such as for the NIJ Spike per NIJ 0115.00, the offset (1) between solid elements must be more than 18% of the spike

diameter, and the gap (2) between solid elements must be less than 15% of the spike diameter. In some embodiments when the threat length after penetration is 5mm, for example threats such as the NIJ P1 blade per NIJ 0115.00, the offset (1) between solid elements must be more than 18% of the p1 blade thickness, and the gap (2) between solid elements must be less than 15% of the p1 blade thickness. And in some embodiments when the threat length after penetration is 5mm, for example threats such as the NIJ S1 Blade per NIJ 0115.00, the offset between solid elements must be more than 12% of the S1 Blade thickness, and the gap between solid elements must be less than 15% of the S1 Blade thickness.

[00100] Figure 8A is a perspective view from above of a pair of triangular TSE 202 and MSE 204 solid elements, where the TSE element 202 has a “hem” shape and the MSE element 204 is flat. Figure 8B is a similar perspective view of an embodiment in which both the TSE element 202 and the MSE element 205 have a “hem” shape.

[00101] Figure 9A is a perspective view from above of three pairs of elements shown together, where the elements are similar to those shown in Figure 8A. Figure 9B is a perspective view from above of three pairs of elements shown together, where the elements are similar to those shown in Figure 8B.

[00102] Figure 10 is a top view of the pairs of Figure 9B, and Figure 11 is a view of the pairs of Figure 9B shown from directly below.

[00103] The foregoing description of the embodiments of the invention has been presented for the purposes of illustration and description. It is not intended to be exhaustive or to limit the invention to the precise form disclosed. Many modifications and variations are possible in light of this disclosure. It is intended that the scope of the invention be limited not by this detailed description, but rather by the claims appended hereto.

CLAIMS

What is claimed is:

- 1 1. A mosaic armor system for protection against a threat having a threat
2 thickness at a failing penetration depth, the armor system comprising:
3 a top layer of solid elements and a middle layer of solid elements, the solid
4 elements in both layers being arranged in substantially space-filling X-Y arrays in
5 which the solid elements are separated from each other by gaps that intersect at
6 apexes, the gaps having a uniform gap width that is between 5% and 20% of the
7 threat thickness at the failing penetration depth, the middle layer being offset from
8 the top layer by an offset that is at least three times larger than the gap width, a
9 front face of the middle layer being adhered to a back face of the top layer; and
10 fibrous top and bottom covering layers arranged so as to sandwich the two
11 layers of solid elements there between.
- 1 2. The mosaic armor system of claim 1, wherein the top fibrous covering layer
2 is adhered to a front face of the top layer of solid elements.
- 1 3. The mosaic armor system of claim 1, wherein the top fibrous covering layer
2 has a recoverable stretch of greater than 30% at less than 20 pounds per inch of
3 load as measured by ASTM method D6614 or D2594.
- 1 4. The mosaic armor system of claim 1, wherein the bottom fibrous covering
2 layer has elongation at break of less than 20%.
- 1 5. The mosaic armor system of claim 1, further comprising an intermediate
2 fibrous layer located between the top layer of solid elements and the middle layer
3 of solid elements.
- 1 6. The mosaic armor system of claim 1, wherein all of the solid elements
2 included in the top and middle layers are made of a material having an Rc
3 hardness of at least 35.

1 7. The mosaic armor system of claim 1, wherein the solid elements of the top
2 and middle layers substantially share the same outline and are aligned with each
3 other.

1 8. The mosaic armor system of claim 1, wherein the offset between the top
2 and middle layers of solid elements is at least four times as large as the first gap
3 size.

1 9. The mosaic armor system of claim 1, further comprising an apex XY layer
2 of solid elements having a front side adhered to a back side of the first fibrous
3 backing layer, the apex solid elements being located directly behind the apexes of
4 the top layer of solid elements.

1 10. The mosaic armor system of claim 9, further comprising a fibrous backing
2 layer adhered to a back side of the apex layer, so that the apex solid elements are
3 sandwiched between the fibrous bottom covering layer and the fibrous apex
4 backing layer.

1 11. The mosaic armor system of claim 10, wherein the fibrous apex backing
2 layer has elongation at break of less than 20%.

1 12. The mosaic armor system of claim 9 further comprising up to 4 fibrous
2 backing layers behind the apex solid element layer.

1 13. The mosaic armor system of claim 9, wherein the apex solid elements have
2 a largest dimension of greater than 0.2 inches.

1 14. The mosaic armor system of claim 9, wherein all of the solid elements
2 included in the apex layer are made of a material having an Rc hardness of at least
3 35.

1 15. The mosaic armor system of claim 1, wherein the armor system defeats
2 both edged blade and spike threats at 45 degrees at energies up to 24 Joules with

3 less than 7mm of penetration, and at 0 degrees at energies up to 36 Joules with
4 less than 20mm of penetration.

1 16. The mosaic armor system of claim 1, wherein a thickness of the solid
2 elements of the middle layer is between 35% and 250% of a thickness of the solid
3 elements of the top layer.

1 17. The mosaic armor system of claim 1, wherein the front face of the middle
2 layer is adhered to the back face of the top layer by a first adhesive that includes a
3 neoprene elastomer.

1 18. The mosaic armor system of claim 1, wherein the top and middle layers of
2 solid elements are attached to each other by an attachment having at least 10 lbf of
3 shear strength per square inch.

1 19. The mosaic armor system of claim 1, wherein the fibrous bottom covering
2 layer is attached to the middle layer of solid elements by an attachment having
3 greater than 10 lbf of shear strength per square inch.

1 20. The mosaic armor system of claim 1, further comprising at least one adhesive layer
2 that includes a neoprene elastomer.

1 21. A mosaic armor system comprising:
2 a top layer of solid elements and a middle layer of solid elements, the solid
3 elements in both layers being arranged in substantially space-filling X-Y arrays in
4 which the solid elements are separated from each other by gaps that intersect at
5 apexes, the solid elements of the top and middle layers substantially sharing the
6 same outline and being aligned with each other, the solid elements of the top layer
7 having edges that are offset in the Z direction from edges of the solid elements in
8 the middle layer by an offset that is greater than a thickness of the top layer solid
9 elements or a thickness of the middle layer solid elements, a front face of the
10 middle layer being adhered to a back face of the top layer; and

11 an apex XY layer of solid elements located directly behind the apexes of
12 the top and middle layers of solid elements.

1 22. The mosaic armor system of claim 21, wherein a thickness of the solid
2 elements of the middle layer is between 35% and 250% of a thickness of the solid
3 elements of the top layer.

1 23. The mosaic armor system of claim 21, further comprising fibrous top and
2 bottom covering layers arranged so as to sandwich the top and middle layers of
3 solid elements there between.

1 24. The mosaic armor system of claim 23, wherein the fibrous top covering
2 layer has a recoverable stretch of greater than 30% at less than 20 pounds per inch
3 of load as measured by ASTM method D6614 or D2594.

1 25. The mosaic armor system of claim 23, wherein the fibrous bottom covering
2 layer has elongation at break of less than 20%.

1 26. The mosaic armor system of claim 23, wherein the fibrous bottom covering
2 layer is attached to the middle layer of solid elements by an attachment having
3 greater than 10 lbf of shear strength per square inch.

1 27. The mosaic armor system of claim 21, further comprising an intermediate
2 fibrous layer located between the top layer of solid elements and the middle layer
3 of solid elements.

1 28. The mosaic armor system of claim 21, wherein the top and middle layers of
2 solid elements are attached to each other by an attachment having at least 10 lbf of
3 shear strength per square inch.

1 29. The mosaic armor system of claim 21, wherein all of the solid elements
2 included in the top and middle layers are made of a material having an Rc
3 hardness of at least 35.

1 30. The mosaic armor system of claim 21, wherein all of the solid elements
2 included in the apex layers are made of a material having an Rc hardness of at
3 least 35.

1 31. The mosaic armor system of claim 21, wherein the armor system defeats
2 both edged blade and spike threats at both 0 degrees and 65 degrees at energies up
3 to 15 Joules with less than 10mm of penetration, and at energies up to 25 Joules
4 with less than 20mm of penetration.

1 32. The mosaic armor system of claim 21, wherein an offset between the top
2 and middle layers of solid elements is greater than or equal to the gap between the
3 solid elements in each of the top and middle layers.

1 33. The mosaic armor system of claim 21, wherein an offset between the top
2 and middle layers of solid elements is greater than or equal to the thickness of the
3 top layer of solid elements or the middle layer of solid elements.

1 34. The mosaic armor system of claim 21, further comprising fibrous top and
2 bottom covering layers arranged so as to sandwich the top and middle layers of
3 solid elements there between, and a fibrous backing layer adhered to a back side
4 of the apex layer, so that the apex solid elements are sandwiched between the
5 fibrous bottom covering layer and the fibrous backing layer.

1 35. The mosaic armor system of claim 34, wherein the fibrous backing layer
2 has elongation at break of less than 20%.

1 36. The mosaic armor system of claim 21 further including up to 4 fibrous
2 backing layers adhered to a back side of the apex solid element layer.

1 37. The mosaic armor system of claim 21, wherein the apex solid elements
2 have a largest dimension that is greater than 0.2 inches.

1 38. The mosaic armor system of claim 21, wherein the front face of the middle
2 layer is adhered to the back face of the top layer by a first adhesive that includes a
3 neoprene elastomer.

1 39. A mosaic armor system comprising:

2 a top layer of solid elements and a middle layer of solid elements, the solid
3 elements in both layers being arranged in substantially space-filling X-Y arrays in
4 which the solid elements are separated from each other by gaps that intersect at
5 apexes, the solid elements of the top and middle layers substantially sharing the
6 same outline and being aligned with each other; and

7 fibrous top and bottom covering layers arranged so as to sandwich the two
8 layers of solid elements there between, the fibrous top covering layer having a
9 recoverable stretch of greater than 30% at less than 20 pounds per inch of load as
10 measured by ASTM method D6614 or D2594, the fibrous bottom covering layer
11 having elongation at break of less than 20%.

1 40. The mosaic armor system of claim 39, wherein the top and middle layers of
2 solid elements are attached to each other by an attachment having at least 10 lbf
3 per square inch of shear strength.

1 41. The mosaic armor system of claim 39, wherein the fibrous bottom covering
2 layer is attached to the middle layer of solid elements by an attachment having
3 greater than 10 lbf of shear strength per square inch.

1 42. The mosaic armor system of claim 39, wherein all of the solid elements
2 included in the top layer are made of a material having an Rc hardness of at least
3 35.

1 43. The mosaic armor system of claim 39, further comprising an intermediate
2 fibrous layer located between the top layer of solid elements and the middle layer
3 of solid elements.

1 44. The mosaic armor system of claim 39, further comprising an apex XY layer
2 of solid elements located directly behind the apexes of the top and middle layers
3 of solid elements.

1 45. The mosaic armor system of claim 44, further comprising a fibrous backing
2 layer adhered to a back side of the apex layer, so that the apex solid elements are
3 sandwiched between the fibrous bottom covering layer and the fibrous backing
4 layer.

1 46. The mosaic armor system of claim 44, further comprising up to 4 fibrous
2 backing layers adhered to a back side of the apex layer, so that the apex solid
3 elements are sandwiched between the fibrous bottom covering layer and the two
4 fibrous backing layers.

1 47. The mosaic armor system of claim 46, wherein at least one of the fibrous
2 backing layers has elongation at break of less than 20%.

1 48. The mosaic armor system of claim 44, wherein the apex solid elements
2 have a largest dimension of greater than 0.2 inches.

1 49. The mosaic armor system of claim 44, wherein all of the solid elements
2 included in the apex layers are made of a material having an Rc hardness of at
3 least 35.

1 50. A mosaic armor system comprising:
2 a top layer of solid elements and a middle layer of solid elements, the solid
3 elements in both layers being arranged in substantially space-filling X-Y arrays in
4 which the solid elements are separated from each other by gaps that intersect at
5 apexes, the solid elements of the top and middle layers substantially sharing the
6 same outline and being aligned with each other;
7 an apex XY layer of solid elements located directly behind the apexes of
8 the top and middle layers of solid elements;

9 a fibrous bottom covering layer arranged between the middle layer of solid
10 elements and the apex layer of solid elements, the fibrous bottom covering layer
11 having elongation at break of less than 20%; and

12 a fibrous backing layer adhered to a back side of the apex layer, so that the
13 apex solid elements are sandwiched between the fibrous bottom covering layer and
14 the fibrous backing layer.

1 51. The mosaic armor system of claim 50, wherein all of the solid elements
2 included in the top and middle layers are made of a material having an Rc
3 hardness of at least 35.

1 52. The mosaic armor system of claim 50, wherein all of the solid elements
2 included in the apex layers are made of a material having an Rc hardness of at
3 least 35.

1 53. The mosaic armor system of claim 50, further comprising an additional
2 fibrous backing layer adhered to a back side of the apex layer, so that the apex
3 solid elements are sandwiched between the fibrous bottom covering layer and the
4 two fibrous backing layers.

1 54. The mosaic armor system of claim 53, wherein at least one of the fibrous
2 backing layers has elongation at break of less than 20%.

1 55. The mosaic armor system of claim 50, wherein the top and middle layers of
2 solid elements are attached to each other by an attachment having at least 10 lbf of
3 shear strength per square inch.

1 56. The mosaic armor system of claim 50, further comprising an intermediate
2 fibrous layer located between the top layer of solid elements and the middle layer
3 of solid elements.

1 57. The mosaic armor system of claim 50, wherein the fibrous bottom covering
2 layer is attached to the middle layer of solid elements by an attachment having
3 greater than 10 lbf of shear strength per square inch.

1 58. The mosaic armor system of claim 50, wherein the apex solid elements
2 have a largest dimension of greater than 0.2 inches.

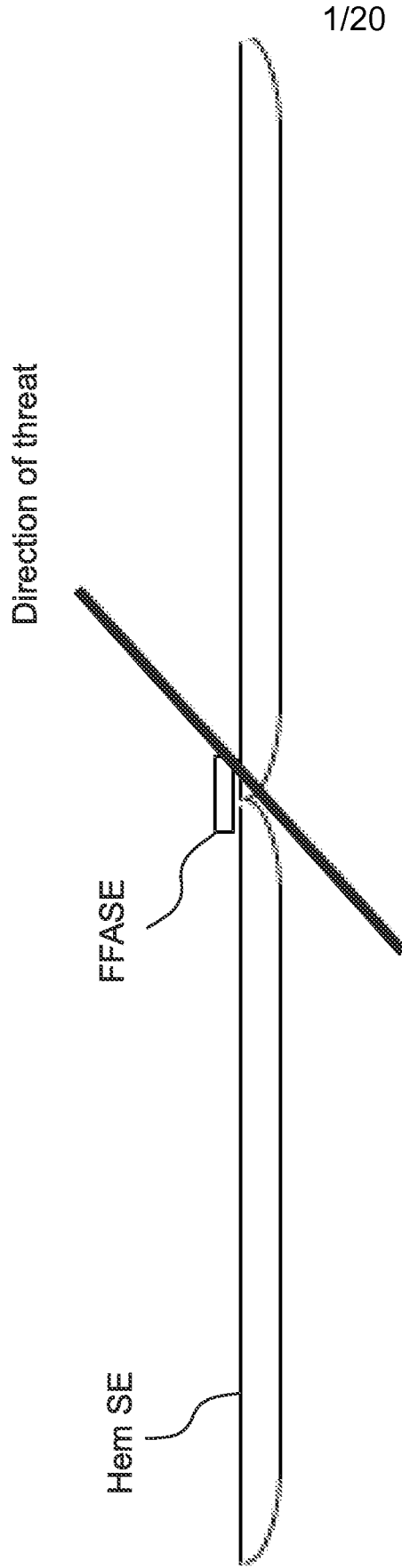

Figure 1
Prior Art

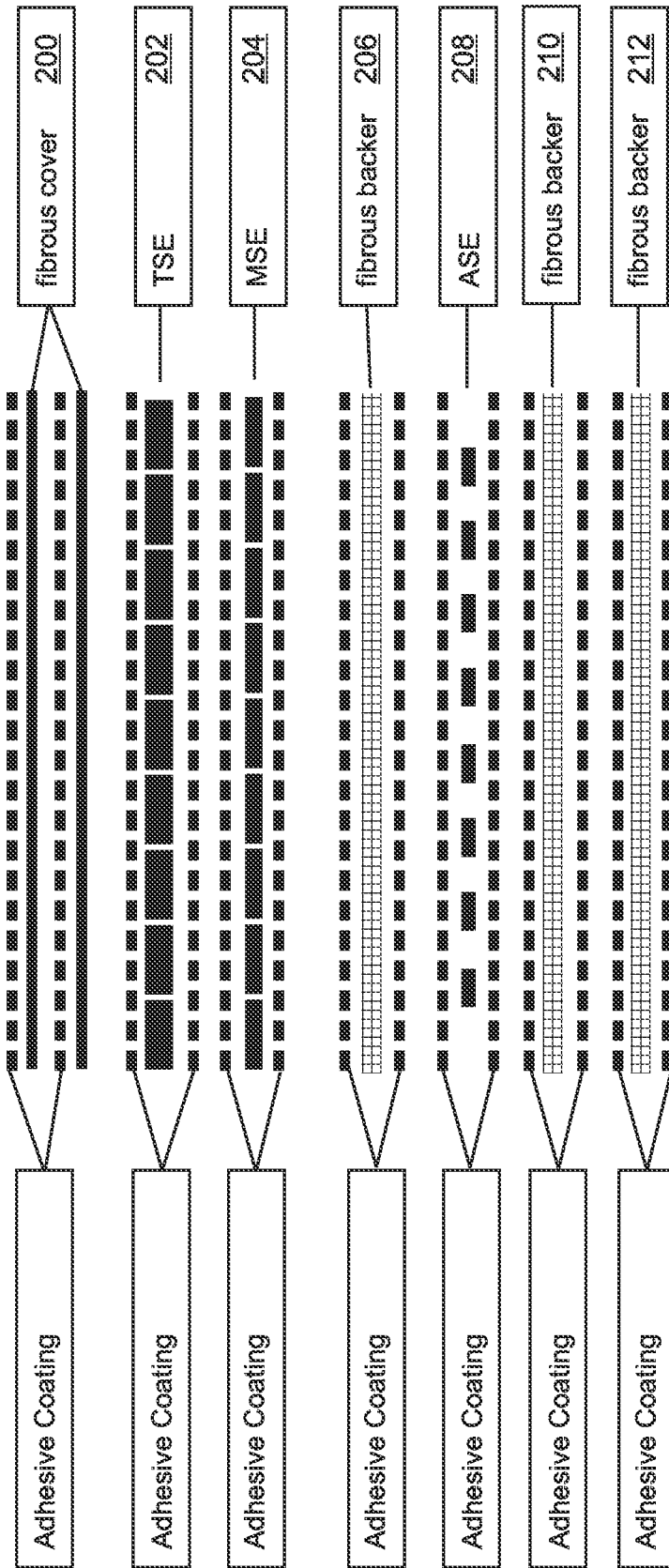

Figure 2A

3/20

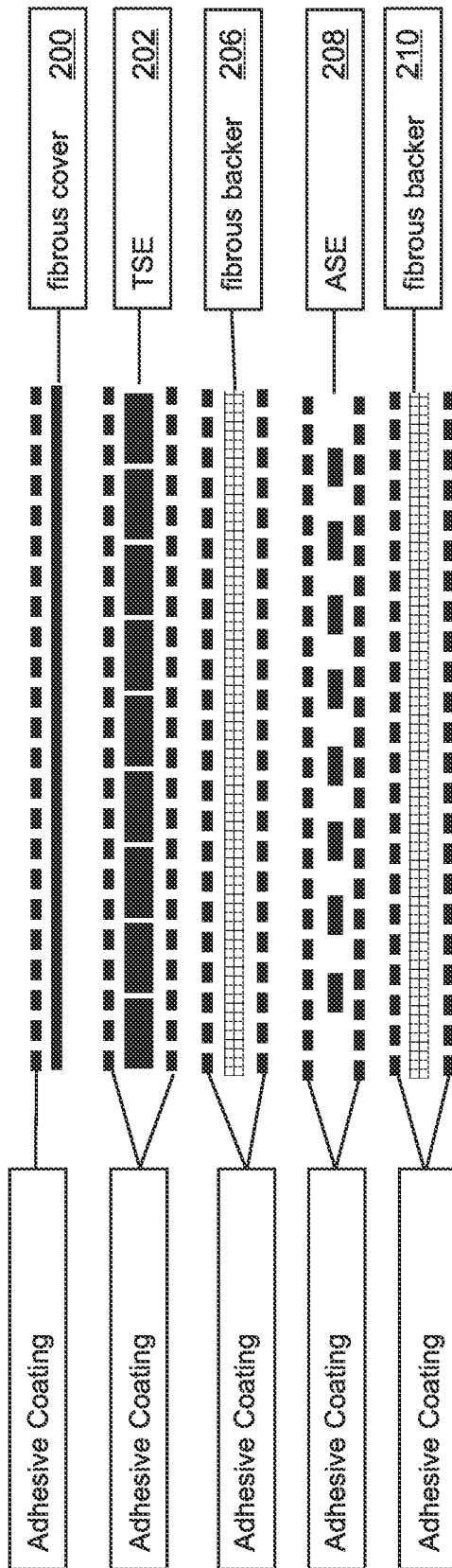

Figure 2B

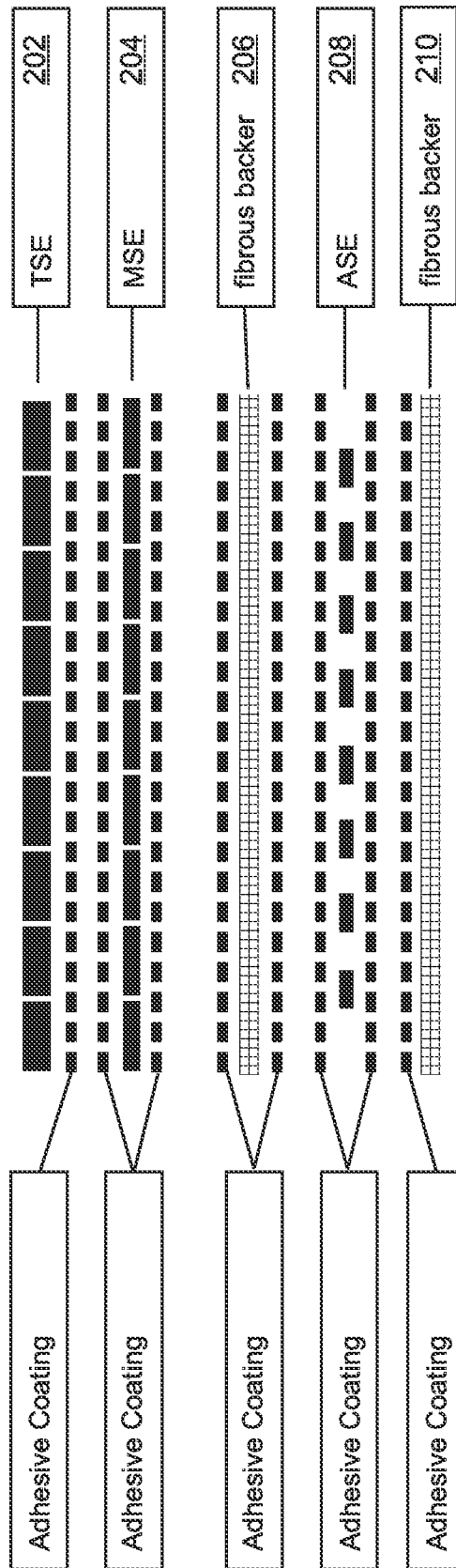

Figure 2C

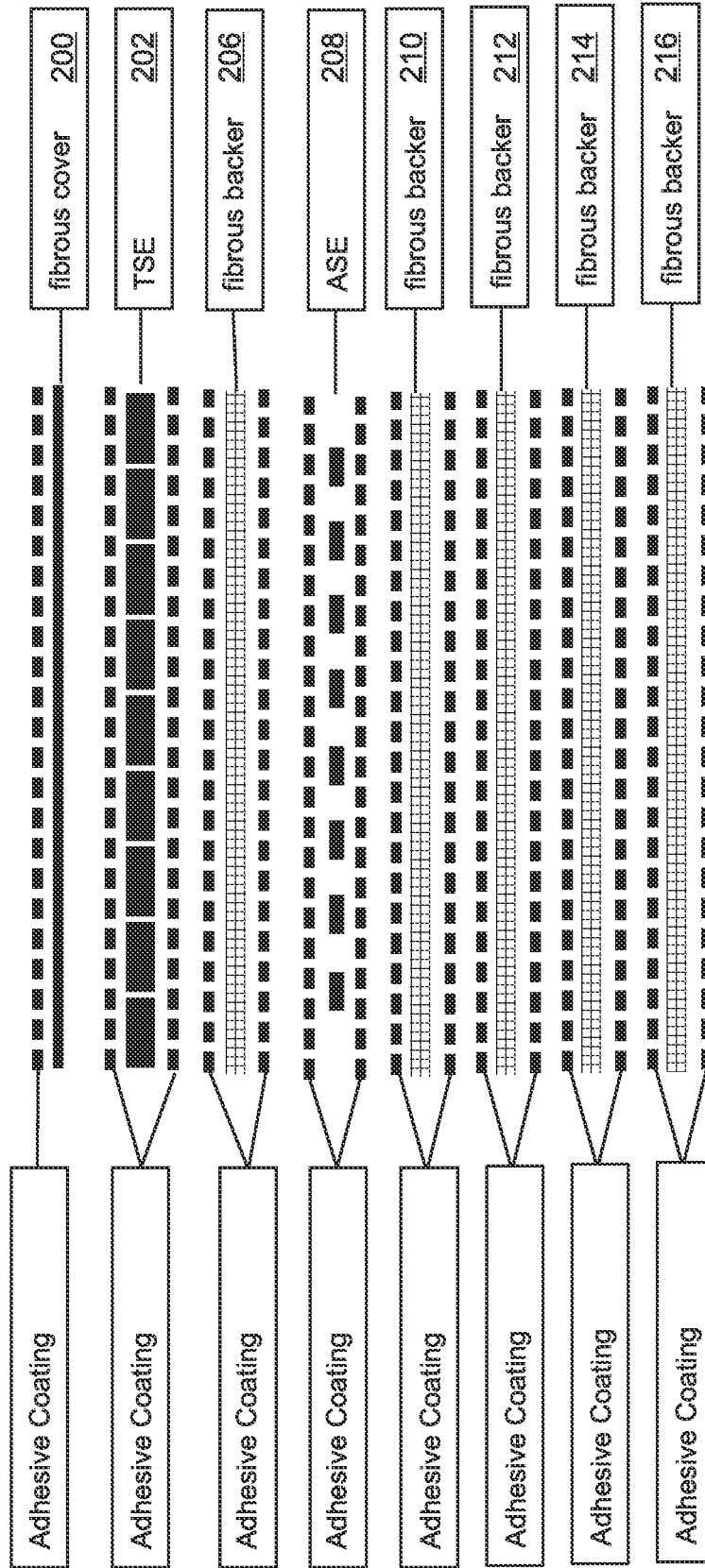

Figure 2D

6/20

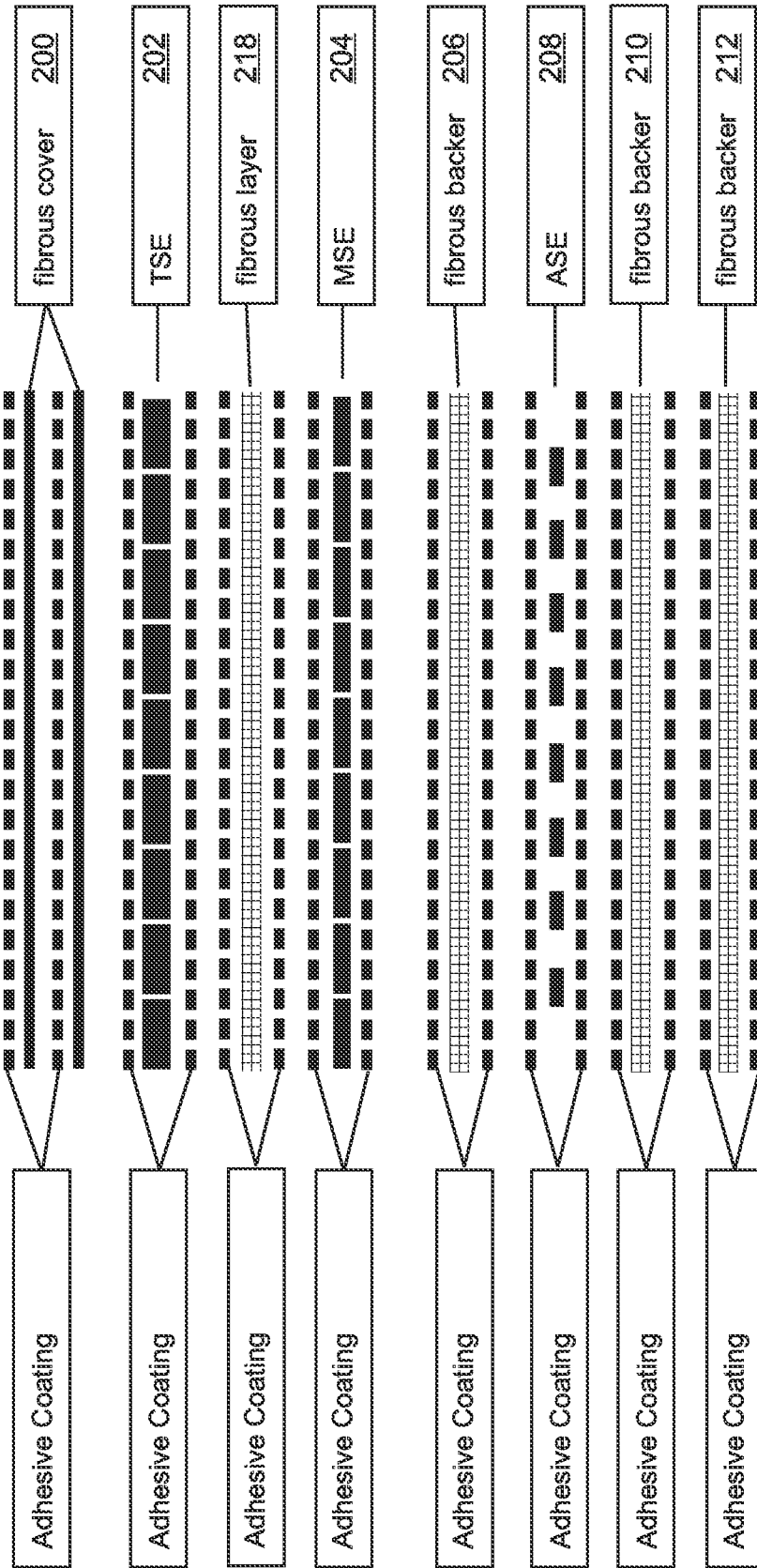
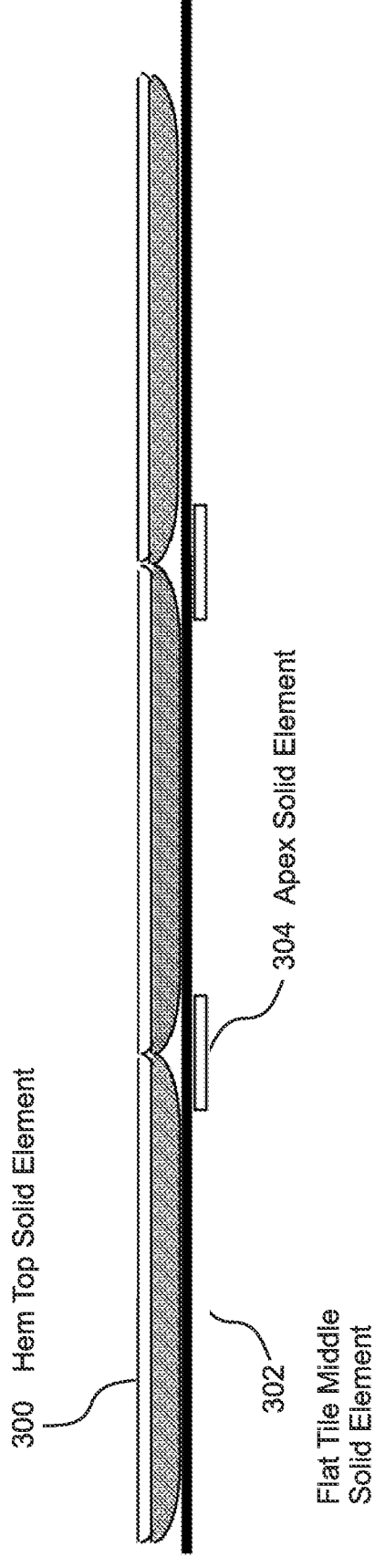
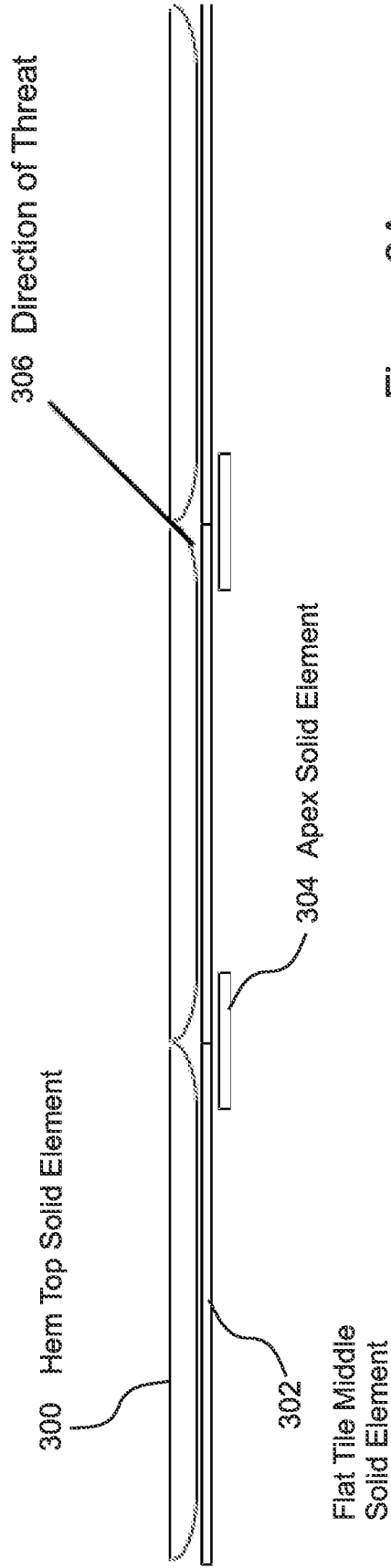

Figure 2E



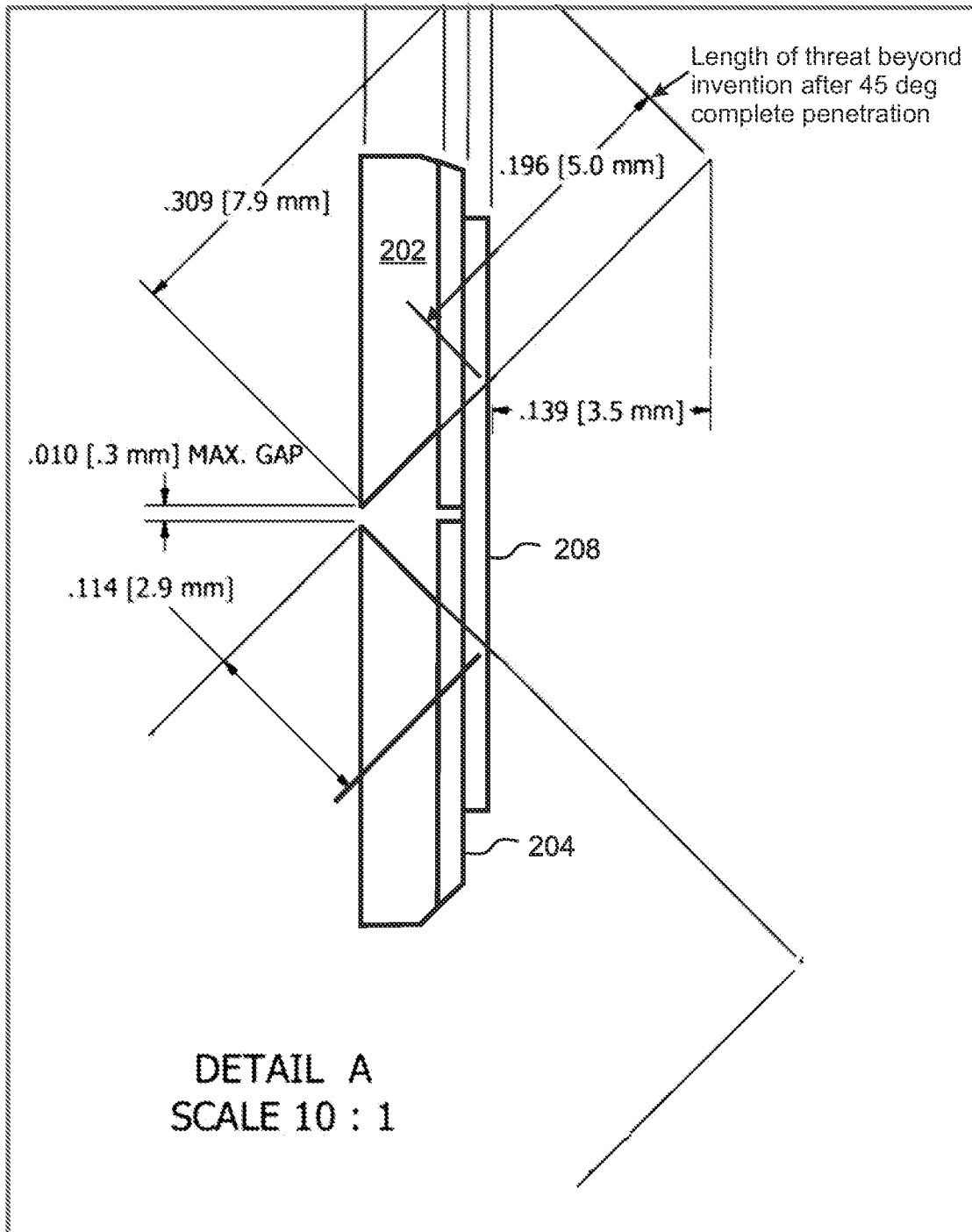

Figure 4

The threat and failure modes are explained in terms of a gap between the solid elements (MSE to MSE) or the offset between the solid elements (MSE to TSE)

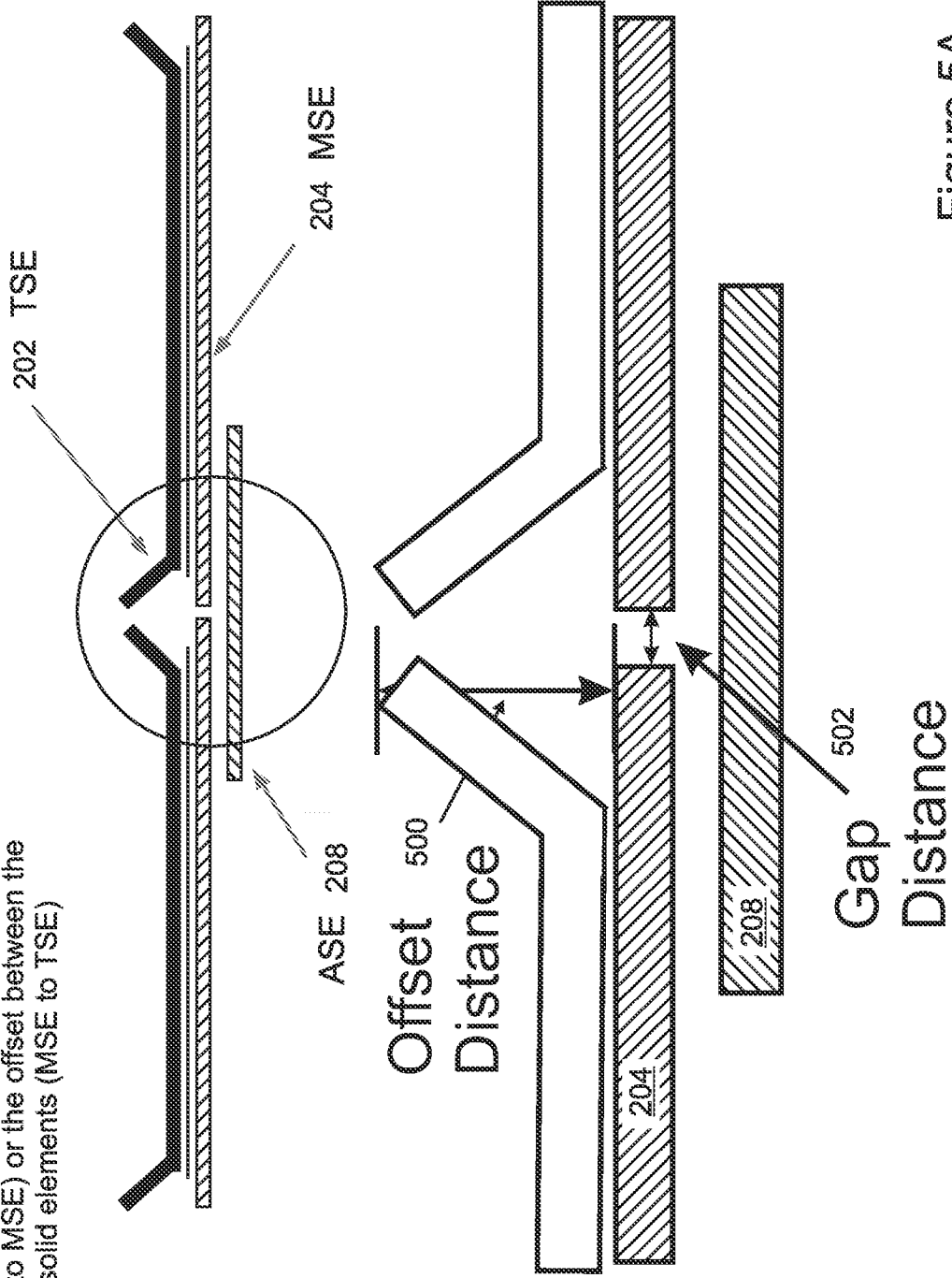
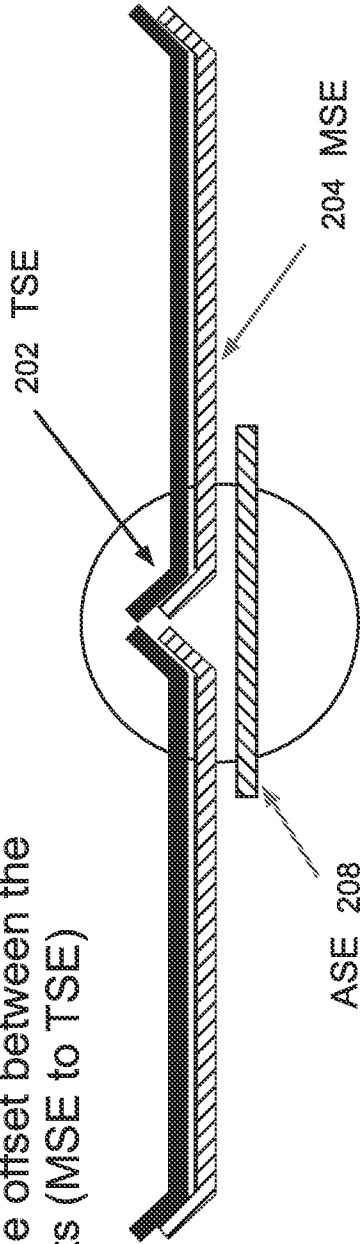

Figure 5A

Figure 5B

The threat and failures modes are explained in terms of a gap between the solid elements (MSE to MSE) or the offset between the solid elements (MSE to TSE)



10/20

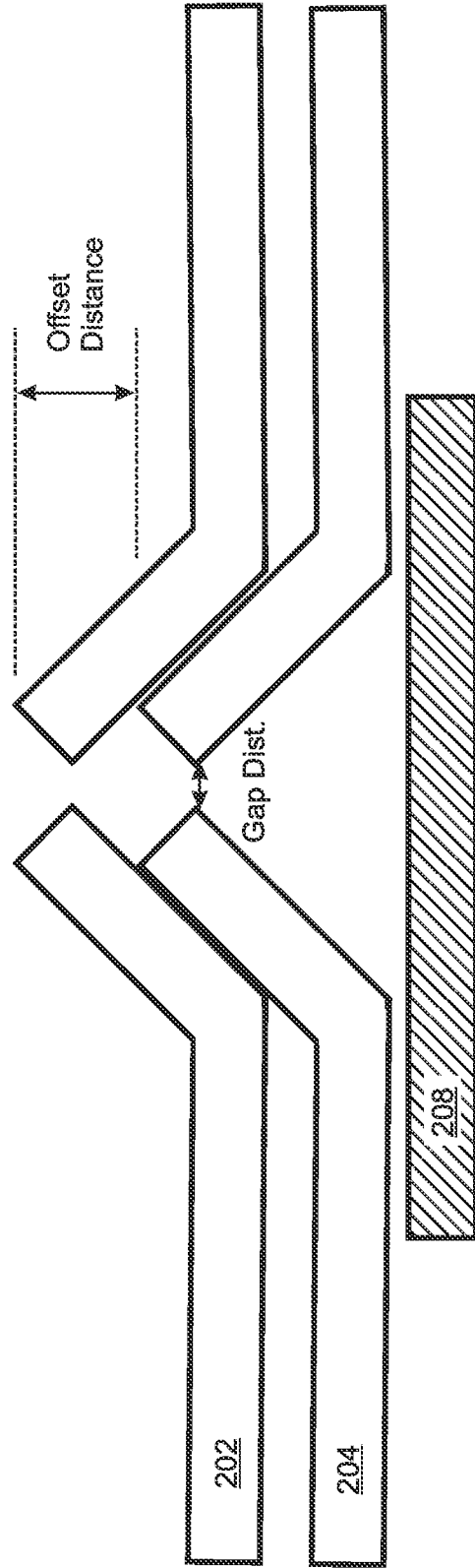

11/20

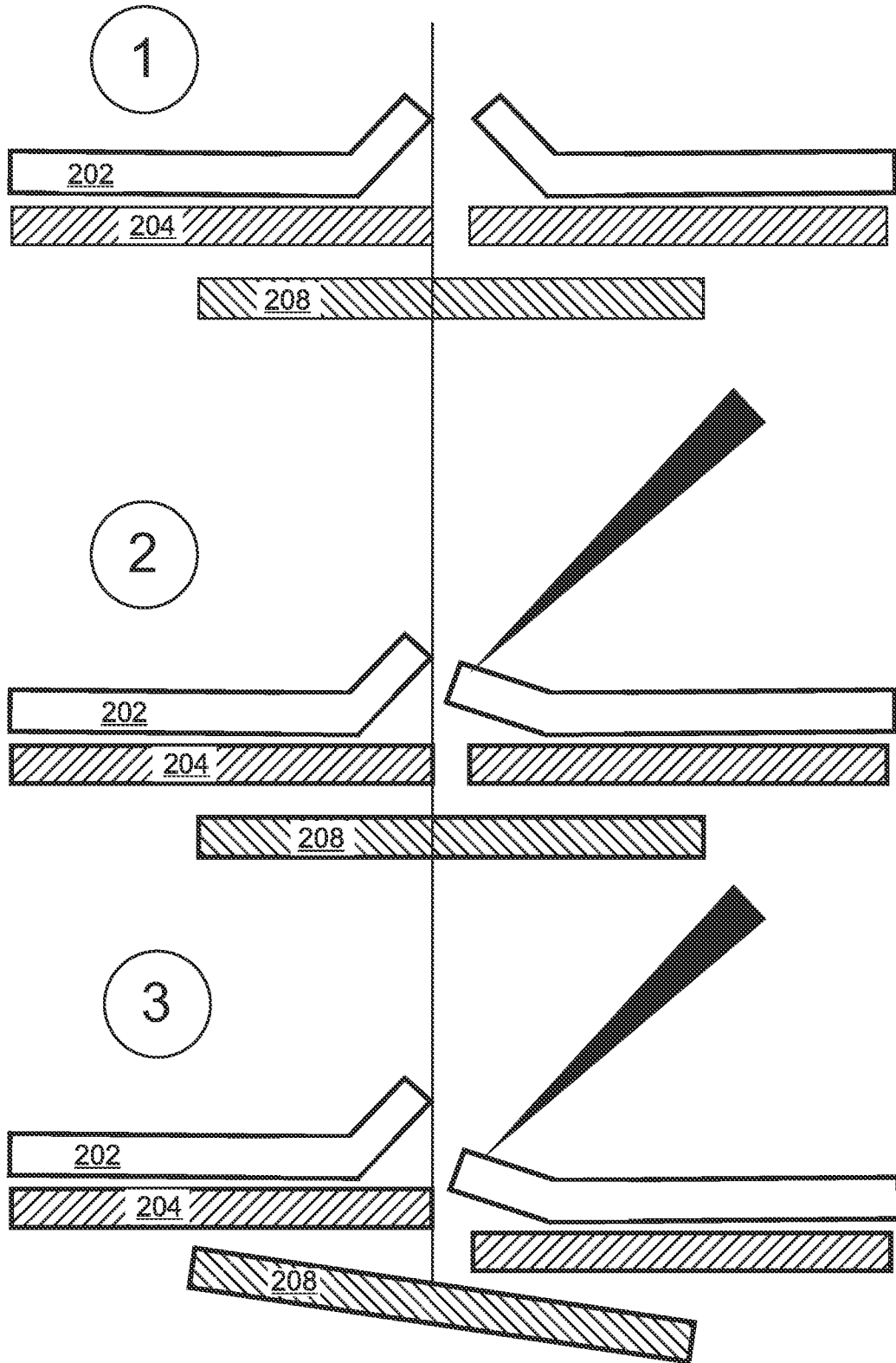

Figure 6A

12/20

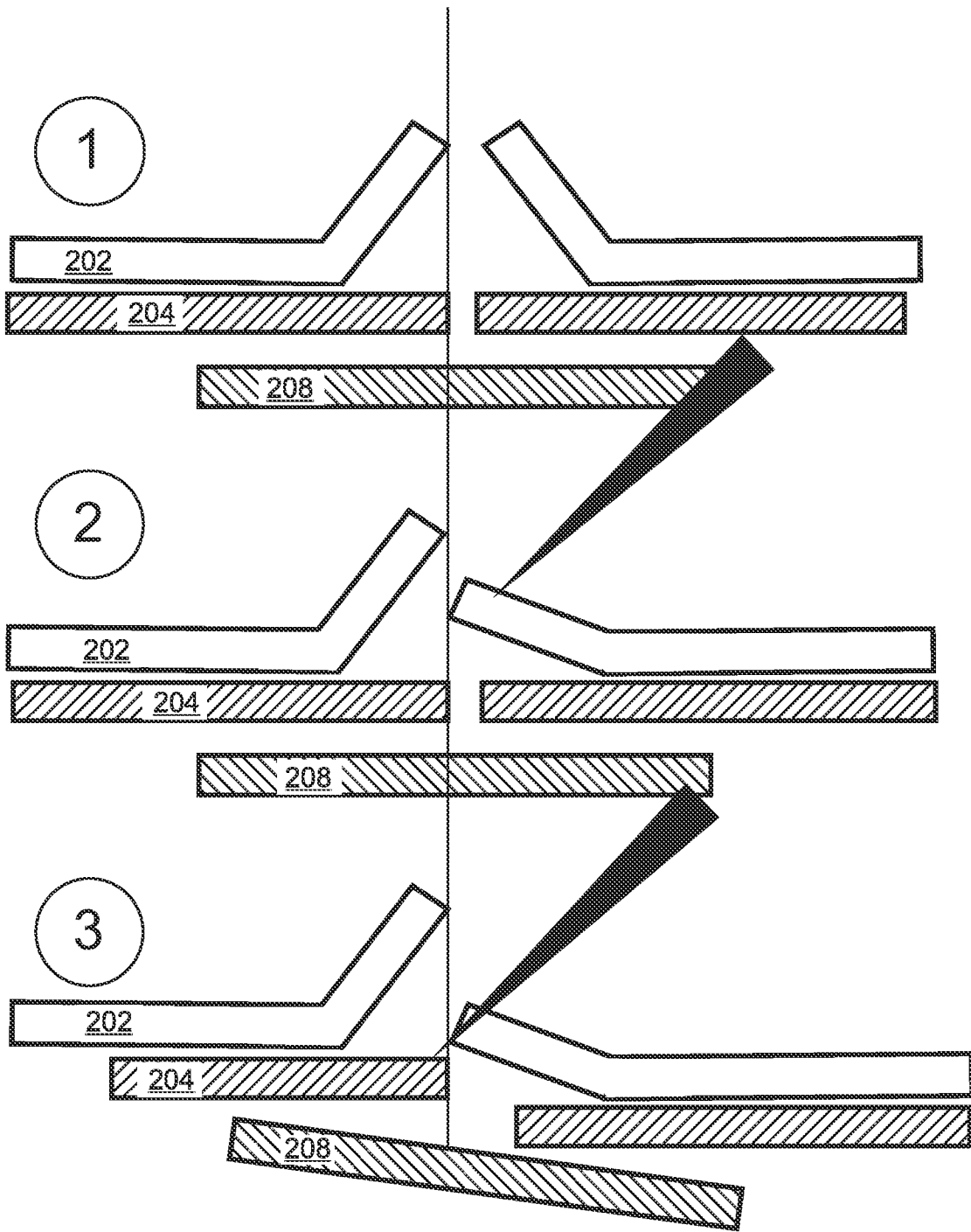

Figure 6B

13/20

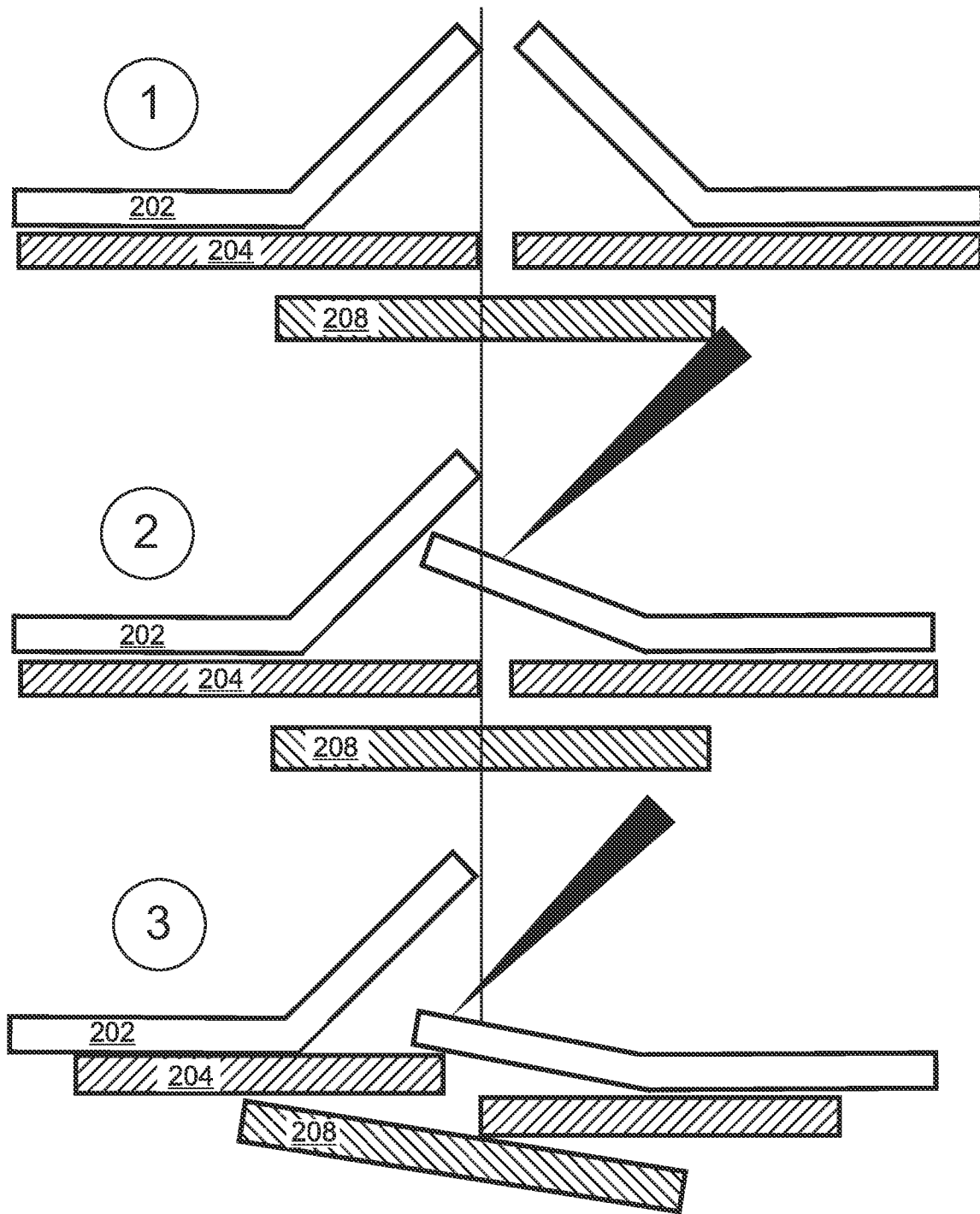

Figure 6C

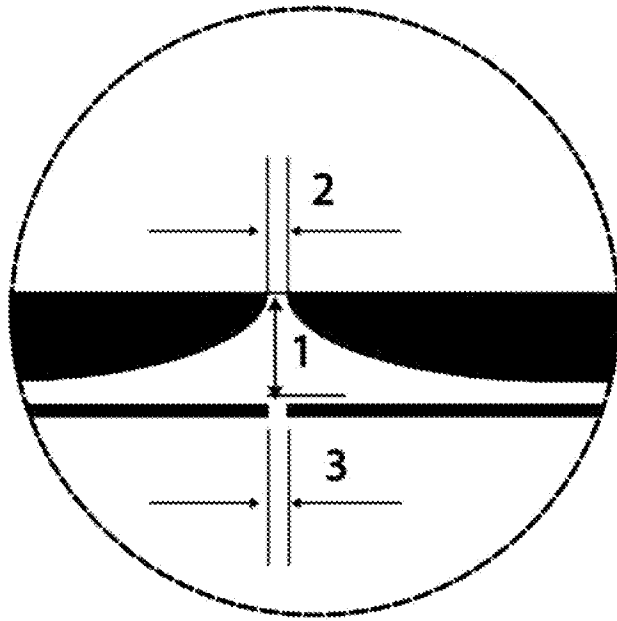

Figure 7A

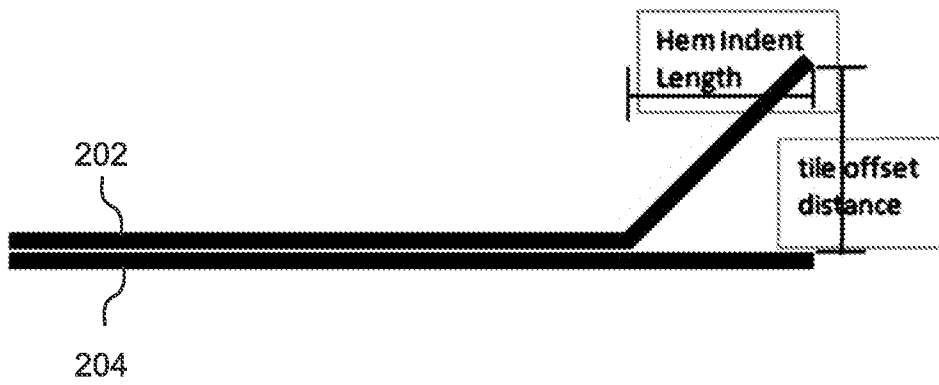

Figure 7B

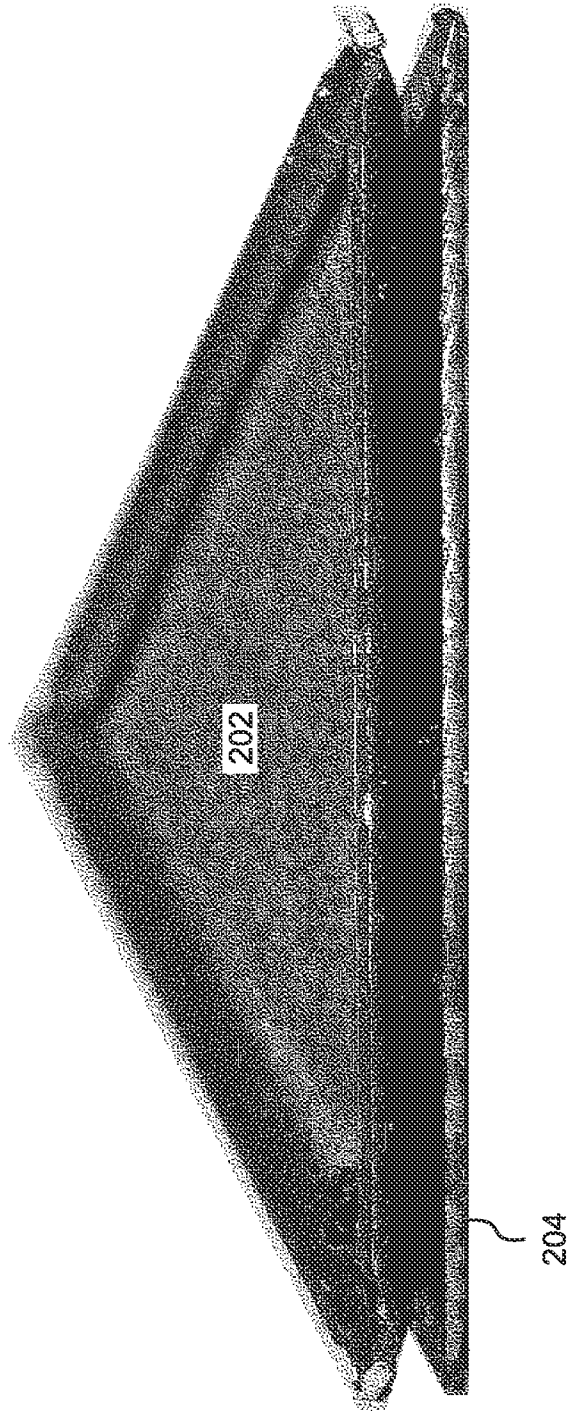

Figure 8A

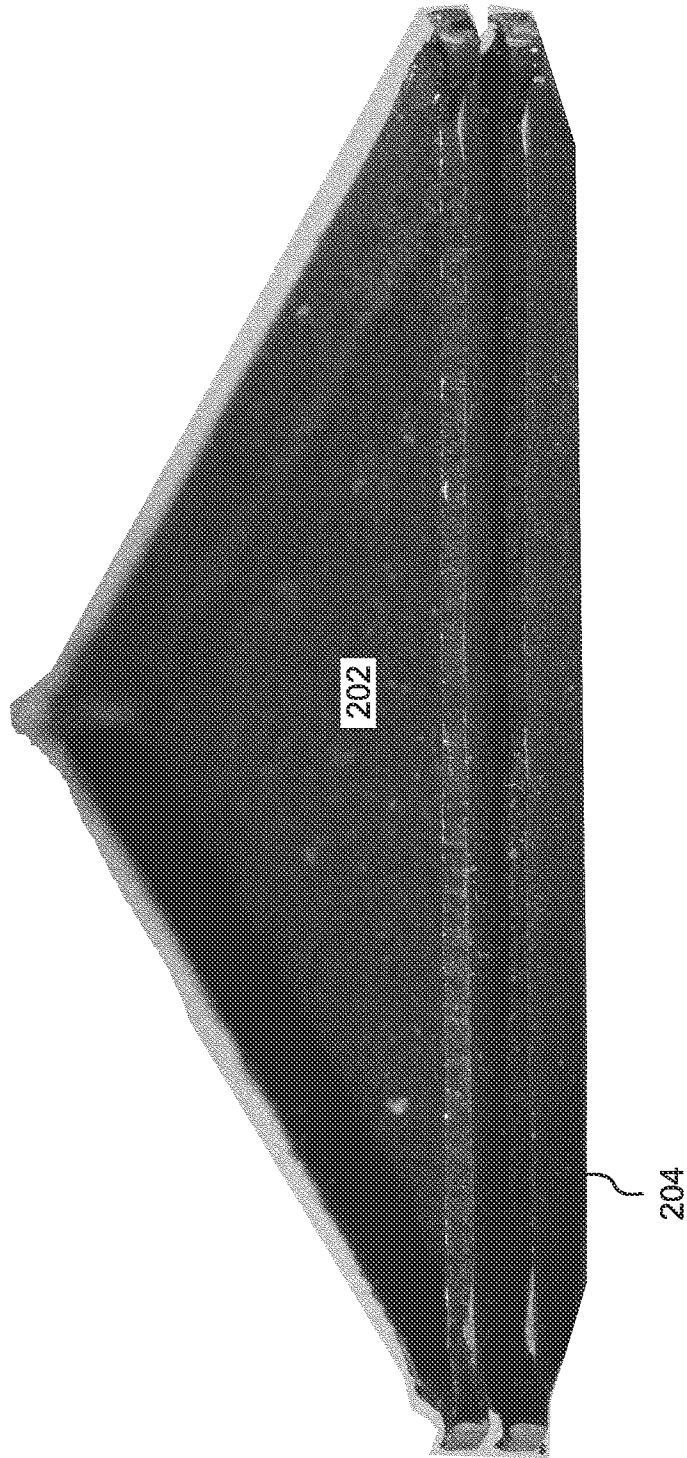

Figure 8B

17/20

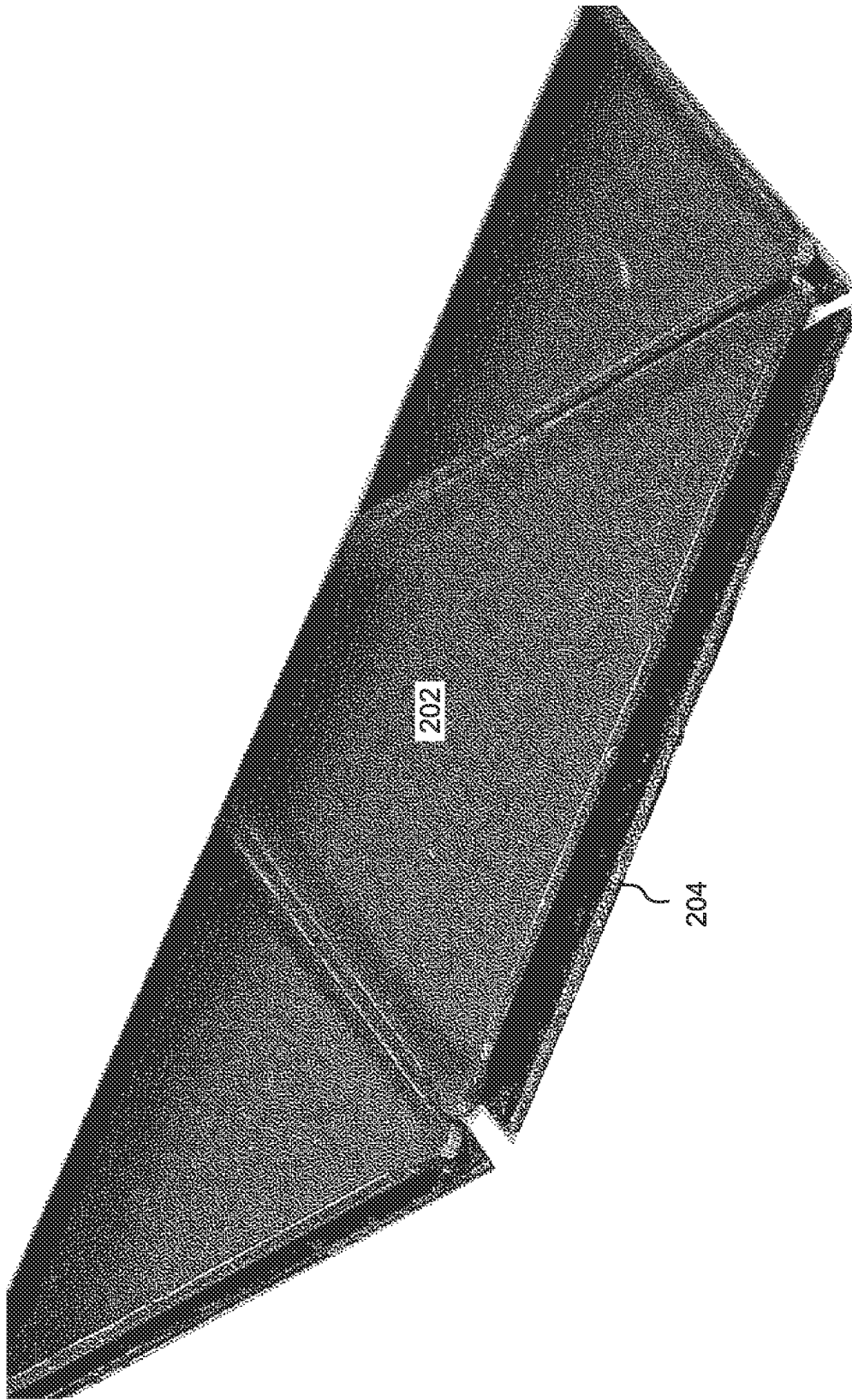

Figure 9A

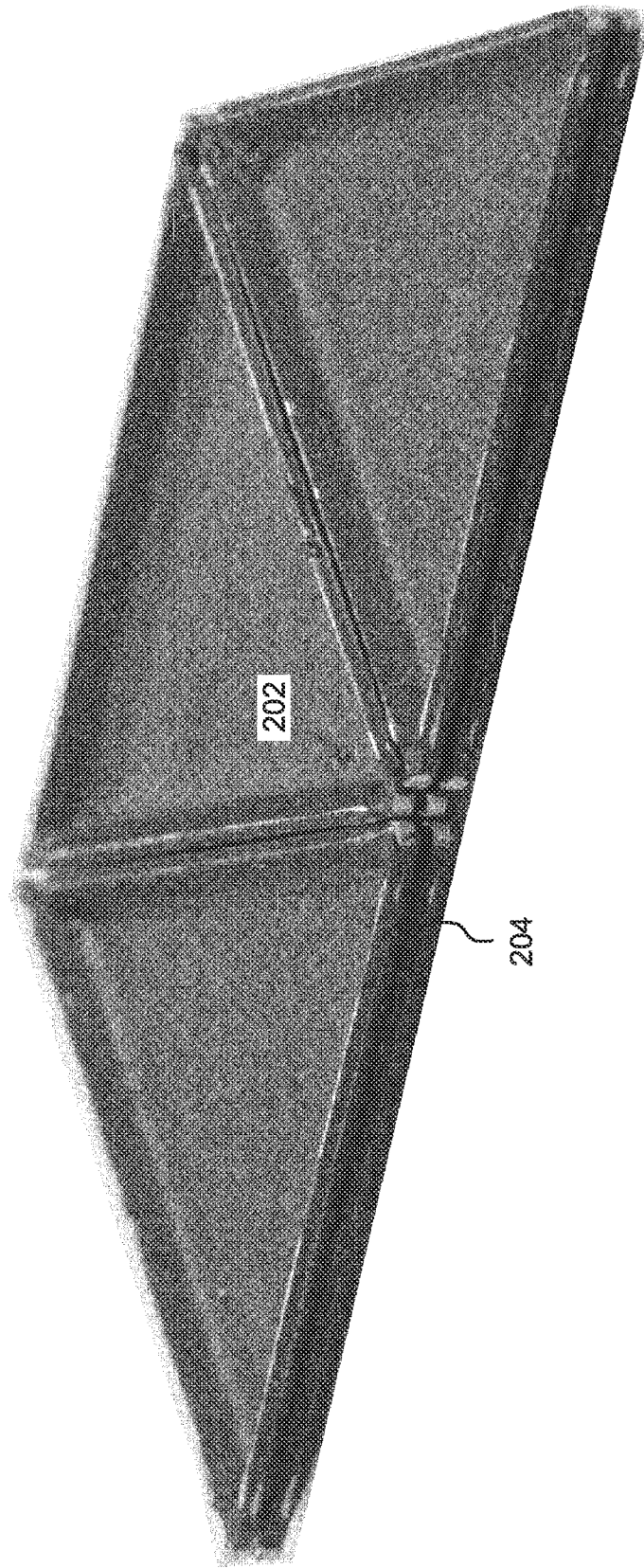

Figure 9B

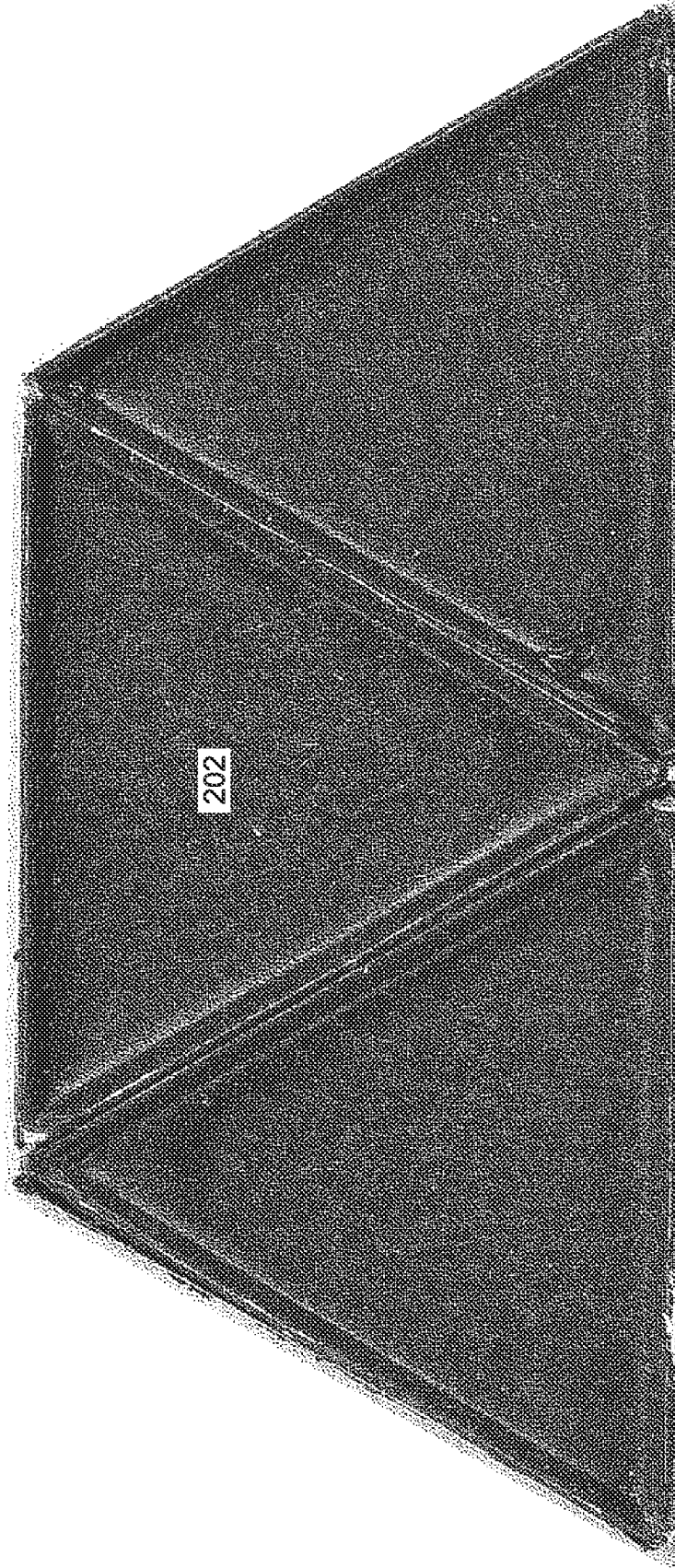

Figure 10

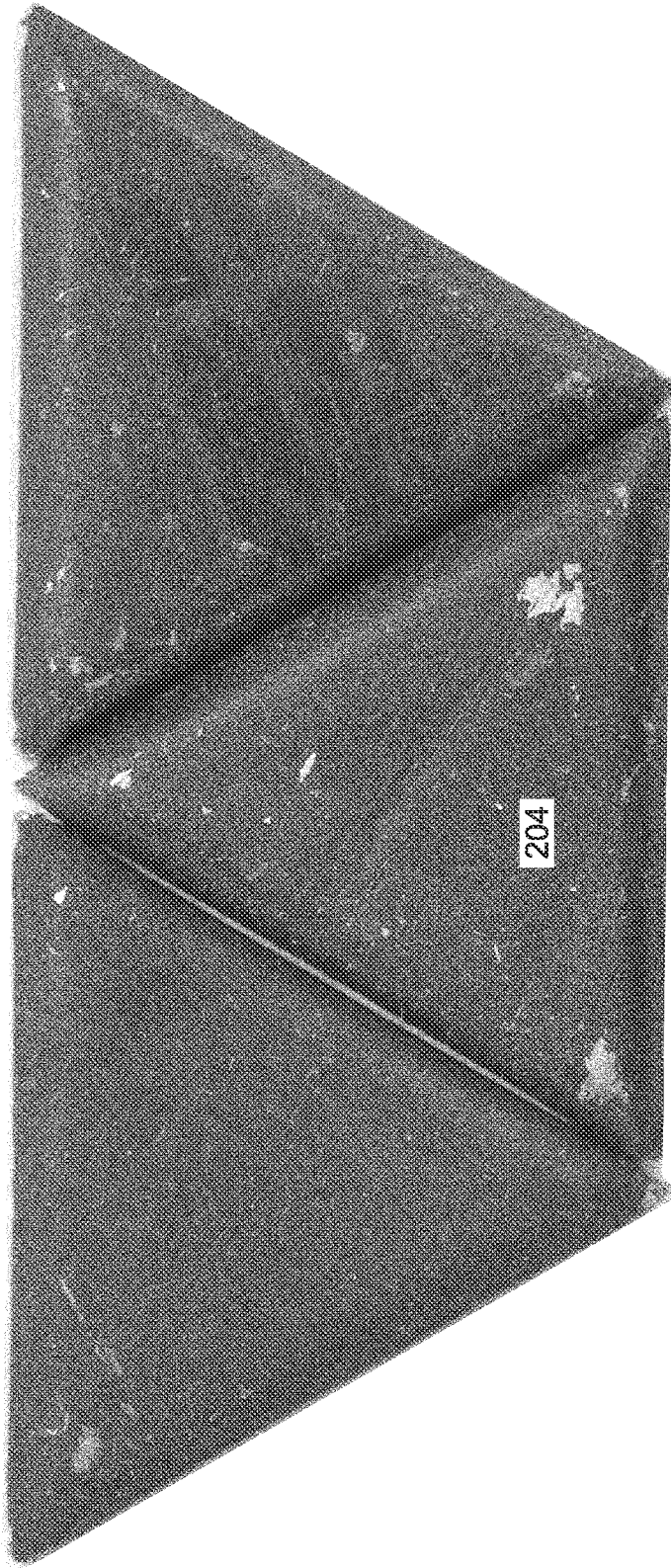

Figure 11

A. CLASSIFICATION OF SUBJECT MATTER**F41H 1/02(2006.01)i, B32B 27/02(2006.01)i**

According to International Patent Classification (IPC) or to both national classification and IPC

B. FIELDS SEARCHED

Minimum documentation searched (classification system followed by classification symbols)

F41H 1/02; D06M 11/00; B32B 27/04; F41H 5/02; F41H 5/08; F41H 5/04; B32B 7/12; B32B 27/24; B32B 27/02

Documentation searched other than minimum documentation to the extent that such documents are included in the fields searched

Korean utility models and applications for utility models

Japanese utility models and applications for utility models

Electronic data base consulted during the international search (name of data base and, where practicable, search terms used)

eKOMPASS(KIPO internal) & Keywords: mosaic, armor, TSE, MSE, ASE, apex solid element, middle solid element, apex solid element

C. DOCUMENTS CONSIDERED TO BE RELEVANT

Category*	Citation of document, with indication, where appropriate, of the relevant passages	Relevant to claim No.
A	US 7874239 B2 (HOWLAND, CHARLES A) 25 January 2011 See abstract, column 10 line 63-column 11 line 31, and figure 1.	1-58
A	US 2009-0320675 A1 (LANDINGHAM et al.) 31 December 2009 See abstract, paragraphs 19-23, and figures 1-4.	1-58
A	US 2005-0164577 A1 (REID et al.) 28 July 2005 See claim 1 and figure 1.	1-58
A	US 2009-0320676 A1 (CRONIN et al.) 31 December 2009 See paragraphs 23-26 and figures 1-3.	1-58
A	US 7964518 B1 (BHATNAGAR et al.) 21 June 2011 See abstract and claim 1.	1-58

 Further documents are listed in the continuation of Box C. See patent family annex.

* Special categories of cited documents:

"A" document defining the general state of the art which is not considered to be of particular relevance

"E" earlier application or patent but published on or after the international filing date

"L" document which may throw doubts on priority claim(s) or which is cited to establish the publication date of another citation or other special reason (as specified)

"O" document referring to an oral disclosure, use, exhibition or other means

"P" document published prior to the international filing date but later than the priority date claimed

"T" later document published after the international filing date or priority date and not in conflict with the application but cited to understand the principle or theory underlying the invention

"X" document of particular relevance; the claimed invention cannot be considered novel or cannot be considered to involve an inventive step when the document is taken alone

"Y" document of particular relevance; the claimed invention cannot be considered to involve an inventive step when the document is combined with one or more other such documents, such combination being obvious to a person skilled in the art

"&" document member of the same patent family

Date of the actual completion of the international search

08 April 2014 (08.04.2014)

Date of mailing of the international search report

08 April 2014 (08.04.2014)

Name and mailing address of the ISA/KR

International Application Division
Korean Intellectual Property Office
189 Cheongsu-ro, Seo-gu, Daejeon Metropolitan City, 302-701,
Republic of Korea

Facsimile No. +82-42-472-7140

Authorized officer

KIM, Jin Ho

Telephone No. +82-42-481-8699



INTERNATIONAL SEARCH REPORT

Information on patent family members

International application No.

PCT/US2013/076831

Patent document cited in search report	Publication date	Patent family member(s)	Publication date
US 7874239 B2	25/01/2011	EP 2016361 A2	21/01/2009
		EP 2016361 A4	21/11/2012
		US 2008-0104735 A1	08/05/2008
		US 2011-0023697 A1	03/02/2011
		WO 2008-054867 A2	08/05/2008
		WO 2008-054867 A3	13/11/2008
US 2009-0320675 A1	31/12/2009	WO 2009-011951 A2	22/01/2009
		WO 2009-011951 A3	23/04/2009
US 2005-0164577 A1	28/07/2005	AU 2003-218113 A1	29/09/2003
		CN 100564659 C	02/12/2009
		CN 1646759 A	27/07/2005
		EP 1485531 A1	15/12/2004
		TW I294939 B	21/03/2008
		US 2003-0060529 A1	27/03/2003
		US 2010-0024134 A1	04/02/2010
		US 6437014 B1	20/08/2002
		US 6803014 B2	12/10/2004
		US 7727286 B2	01/06/2010
		WO 03-078723 A1	25/09/2003
US 2009-0320676 A1	31/12/2009	CA 2542025 A1	06/05/2005
		CA 2542025 C	15/12/2009
		EP 1678461 A1	12/07/2006
		EP 1678461 A4	29/09/2010
		IL 174938 D0	20/08/2006
		US 7540228 B1	02/06/2009
		WO 2005-040711 A1	06/05/2005
US 7964518 B1	21/06/2011	CA 2796645 A1	27/10/2011
		CN 102933758 A	13/02/2013
		EP 2561132 A2	27/02/2013
		EP 2561132 A4	30/10/2013
		JP 2013-529282 A	18/07/2013
		MX 2012012090 A	22/01/2013
		TW 201142105 A	01/12/2011
		WO 2011-133295 A2	27/10/2011
		WO 2011-133295 A3	19/04/2012