

(19) World Intellectual Property Organization  
International Bureau



(43) International Publication Date  
9 June 2011 (09.06.2011)

(10) International Publication Number  
**WO 2011/066928 A1**

(51) International Patent Classification:

*G01L 1/24* (2006.01)      *G01D 5/353* (2006.01)  
*G01L 5/00* (2006.01)      *G01M 13/04* (2006.01)

(21) International Application Number:

PCT/EP2010/007190

(22) International Filing Date:

26 November 2010 (26.11.2010)

(25) Filing Language:

English

(26) Publication Language:

English

(30) Priority Data:

61/283,557      4 December 2009 (04.12.2009)      US

(71) Applicant (for all designated States except US): **AK-TIEBOLAGET SKF (publ)** [SE/SE]; S-415 50 Göteborg (SE).

(72) Inventor; and

(75) Inventor/Applicant (for US only): **REEDMAN, Adam, Victor, Creyke** [GB/NL]; Lage Giessen 35, NL-4223 SH Hoornaar (NL).

(74) Agent: **BURÖ, Sven, Peter**; SKF B.V., P.O. Box 2350, NL-3430 DT Nieuwegein (NL).

(81) Designated States (unless otherwise indicated, for every

kind of national protection available): AE, AG, AL, AM, AO, AT, AU, AZ, BA, BB, BG, BH, BR, BW, BY, BZ, CA, CH, CL, CN, CO, CR, CU, CZ, DE, DK, DM, DO, DZ, EC, EE, EG, ES, FI, GB, GD, GE, GH, GM, GT, HN, HR, HU, ID, IL, IN, IS, JP, KE, KG, KM, KN, KP, KR, KZ, LA, LC, LK, LR, LS, LT, LU, LY, MA, MD, ME, MG, MK, MN, MW, MX, MY, MZ, NA, NG, NI, NO, NZ, OM, PE, PG, PH, PL, PT, RO, RS, RU, SC, SD, SE, SG, SK, SL, SM, ST, SV, SY, TH, TJ, TM, TN, TR, TT, TZ, UA, UG, US, UZ, VC, VN, ZA, ZM, ZW.

(84) Designated States (unless otherwise indicated, for every

kind of regional protection available): ARIPO (BW, GH, GM, KE, LR, LS, MW, MZ, NA, SD, SL, SZ, TZ, UG, ZM, ZW), Eurasian (AM, AZ, BY, KG, KZ, MD, RU, TJ, TM), European (AL, AT, BE, BG, CH, CY, CZ, DE, DK, EE, ES, FI, FR, GB, GR, HR, HU, IE, IS, IT, LT, LU, LV, MC, MK, MT, NL, NO, PL, PT, RO, RS, SE, SI, SK, SM, TR), OAPI (BF, BJ, CF, CG, CI, CM, GA, GN, GQ, GW, ML, MR, NE, SN, TD, TG).

Published:

— with international search report (Art. 21(3))

(54) Title: BEARING MONITORING USING A FIBER BRAGG GRATING

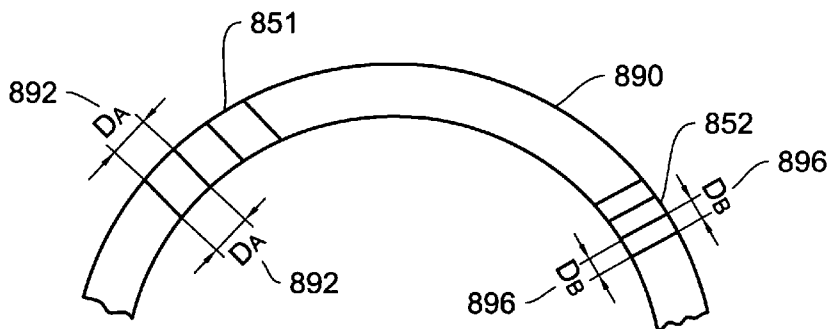

FIG 8A

(57) Abstract: A bearing comprises a Bragg grating optical fiber to measure one or more parameters of the bearing. The optical fiber is coupled to the bearing in such a way that at least a part of the optical fiber that comprises Bragg grating is curved. The grating which is curved is adapted to the curvature in such a way that the frequency response is well defined and not spread out. This is achieved by arranging the gratings such that even though the fiber is curved the gratings appear to be substantially parallel instead of being influenced by the curvature.

WO 2011/066928 A1

## BEARING MONITORING USING A FIBER BRAGG GRATING

5

### TECHNICAL FIELD

The invention is related to condition monitoring of bearings, in particular in combination with load sensing.

10 BACKGROUND

Bearings are a very important component in rotating machinery. If a bearing fails, then the complete functionality of the machinery usually also fails. In some applications it might be very difficult or just extremely expensive to replace a failed bearing outside regular scheduled maintenance. Such applications might be deep sea applications, cruise ships or other continuous manufacturing lines. In an attempt to predict when a bearing needs to be replaced before it fails and suitable also in an orderly scheduled manner, condition monitoring is done. If the machinery and bearings are physically in a location which is easily accessible, then the condition of a bearing can be assessed by for example vibration measurement. Equipment which is not accessible, such as deep sea applications need other means to assess the condition of a bearing to be able to assess when maintenance is needed. There are many ways of remotely assess the condition of a bearing, however, there seems to still be room for improvement.

25

### SUMMARY

An object of the invention is to define a method and means to monitor the condition and load of a bearing. Load that a bearing is subjected to can influence the bearing life.

30

Another object of the invention is to define a unit for monitoring the condition and measure the load of a bearing without any electrical power at the bearing.

A further object of the invention is to define a Bragg grating optical fiber suitable for monitoring the condition and measuring the load of a bearing by measuring strain on the optical fiber.

5

The aforementioned objects are achieved according to the invention by the use of a Bragg grating optical fiber to sense the condition of a bearing and the load of the bearing, the bearing comprising a groove to increase the sensitivity of the fiber to both load variations and vibrations of the bearing.

10

The aforementioned objects are further achieved according to the invention by a bearing comprising a Bragg grating optical fiber having a plurality of grating areas, where physically adjacent grating areas are separated in the frequency plane. Suitably adjacent frequency bands correspond to grating areas on opposite sides of a bearing.

15

The aforementioned objects are also achieved according to the invention by a Bragg grating optical fiber for attachment on a circular circumference of a bearing, where the gratings are made to be parallel when the optical fiber is attached to the bearing.

20

The aforementioned objects are also achieved according to the invention by a bearing comprising a Bragg grating optical fiber for measuring one or more parameters of the bearing. The Bragg grating optical fiber is attached to the bearing such that at least one grating of the optical fiber is curved. According to the invention the grating of the Bragg grating optical fiber is adapted to the curvature in such a way that the influence on the frequency response due to the curvature is minimized.

25

Preferably the gratings of the grating are substantially parallel when the optical fiber grating is curved. The gratings can be made before the optical fiber is attached to the bearing. The gratings are then made such that when

30

the expected curvature of the optical fiber is done, the gratings are substantially parallel. The gratings can also be made when the optical fiber is attached to the bearing. The gratings are then being made such that they are substantially parallel when the optical fiber is mounted. In some  
5 embodiments the optical fiber has at least one flat surface, that is a non-circular cross section. This is to be able to define the orientation of the optical fiber and thereby attach the fiber to the bearing in a predetermined orientation.

10 The aforementioned objects are also achieved according to the invention by a bearing that comprises a Bragg grating optical fiber to measure one or more parameters of the bearing. The optical fiber is coupled to the bearing in such a way that at least a part of the optical fiber that comprises Bragg grating is curved. The grating which is curved is adapted to the curvature in such a  
15 way that the frequency response is well defined and not spread out. This is achieved by arranging the gratings such that even though the fiber is curved the gratings appear to be substantially parallel instead of being influenced by the curvature.

20 By providing a method and a unit for sensing strain by optical means, condition monitoring and load measurements can be calculated kilometers away from the bearing by the transmission of strain data by optical means. Thus there is no need to provide any electrical power at the bearing. Applications such as monitoring bearings of deep sea pumps, kilometers under the sea surface, is  
25 made possible in a reliable manner without any electrical power locally at the bearing.

Other advantages of the invention will become apparent from the detailed description below.

30

BRIEF DESCRIPTION OF THE DRAWINGS

The invention will now be described in more detail for explanatory, and in no sense limiting, purposes, with reference to the following figures, in which:

- 5 Fig. 1 shows a side view of a bearing in a housing, a typical implementation of the invention,
- Fig. 2 shows a cross section of a part of a bearing according to one embodiment according to the invention,
- 10 Fig. 3 shows a cross section of a part of a bearing according to another embodiment according to the invention,
- Fig. 4 shows a top view of a bearing according to the invention illustrating optical fiber access to measurement groove,
- 15 Fig. 5A shows a side sectional view of a bearing according to the invention illustrating an example of sensor distribution according to the invention around the bearing,
- 20 Fig. 5B shows the sensor frequency distribution according to the sensor placement of fig. 5A,
- Fig. 6A shows a conventional optical fiber with Bragg grating,
- 25 Fig. 6B shows the frequency response of the optical fiber of fig. 6A,
- Fig. 7A shows a conventional optical fiber with Bragg grating that is bent, such as around a circular bearing,
- 30 Fig. 7B shows the frequency response of the bent optical fiber of fig. 7A,

Fig. 8A shows a bent optical fiber with Bragg grating according to the invention,

5 Fig. 8B shows the frequency response of the optical fiber according to the invention of fig. 8A,

#### DETAILED DESCRIPTION

In order to clarify the inventions, some examples of its use will now be described in connection with Figures 1 to 8B.

10

Figure 1 illustrates a side view of a bearing 110 mounted in a housing 120. The bearing 110 comprises an outer 112, non-rotating, ring, an inner 114, rotating, ring with rolling elements 116 there between. This is a typical implementation of the inventions. An optical strain gauge, typically a Bragg grating optical fiber strain sensing unit, is according to the invention placed in a groove in the outer 15 112 non-rotating ring. The groove has to be large enough to accommodate the optical fiber, otherwise the bearing will not fit in the housing 120. The groove also have to be large enough and placed such that the sensitivity of the strain sensors is increased. This is due to weakening of the outer ring 112, such that 20 for the same forces on the bearing, the bearing is deformed more thus putting a greater strain on the strain sensors. The groove must at the same time be small enough so that the integrity of the bearing is not jeopardized, that is if the groove is made too large, then the bearing will not be able to sustain its stated capacity. There is thus a compromise between these two conditions, which is 25 also helped by clever placement of the groove.

Figure 2 illustrates a cross section of a part of a bearing according to one embodiment of the invention. The bearing is a two row SRB comprising two outer rings 212, 213, each having a corresponding set of rolling elements 216, 30 217. In this embodiment, each row comprises a corresponding groove 230, 231. Each groove will have a width 235 and a height/depth 234. Suitable each groove will have a slit 238, 239 for placement of the optical fiber. The

placement of the groove 230, 231 and specifically the corresponding slit 238, 239, is preferably along a load line 237 of each corresponding row. An optical fiber can go completely around a bearing, with strain sensing places, by means of grated section, suitably placed. That is one optical fiber comprising all the required grated sections. Alternatively, several optical fibers can be placed with their corresponding grated sections placed at different places.

Figure 3 shows a cross section of a part of a bearing, a CARB, according to another embodiment according to the invention. This embodiment only comprises one outer ring 312 with one row of rolling elements 316, but multiple grooves 330, 331, 332.

Figure 4 illustrates a top view of a bearing according to the invention illustrating optical fiber access means 440 to measurement grooves 430, 431 in its outer ring 412.

Figure 5A illustrates a side sectional view of a bearing 500 with a non-rotating outer ring 512, rotating inner ring 514 with rolling elements 516 there between, according to the invention illustrating an example of sensor distribution 551, 552, 553, 554, 555, 556, 557, 558 according to the invention around the bearing. A Bragg grated optical fiber 550, will comprise one or more strain sensors 551, 552, 553, 554, 555, 556, 557, 558, each sensor defined by a grated section. Each grated section, as seen in detail below in relation to fig. 5B will be represented in the frequency plane by a frequency 571, 572, 573, 574, 575, 576, 577, 578, that will vary in dependence on the strain of the corresponding grated section.

If a sensor is in the loaded zone 562, then large variations 580 will result, sensors in the un-loaded zone will show small frequency variations, due to there being only small 584, if any load and load variations. There are of course sensors in between, with medium variations 582. According to the invention to use the fiber in an optimal way, to get in as many sensors as possible, without

the frequency variations hitting each other, sensors are physically separated such that in the frequency spectrum adjacent sensor frequencies do not vary to a large 580 degree. Since a bearing will always have a loaded zone and an un-loaded zone on its opposite side, then sensor adjacent in frequency, will be placed physically on opposite sides of the bearing.

Figure 6A shows a conventional optical fiber 690 with Bragg grating, arranged flat. It comprises a first strain sensor 651 with a first strain sensor grating separation DA 692, and a second strain sensor 652 with a second strain sensor grating separation DB 696. The gratings will be evenly spaced through a cross section of the optical fiber and thus create, as can be seen in fig. 6B nice peak frequency responses 671, 672 from each sensor.

Figure 7A illustrates a conventional optical fiber 790 with Bragg grating that is bent, such as around a circular bearing. It also comprises a first strain sensor 751 and a second strain sensor 752. But as can be seen, when the fiber is bent, the inner side is compressed and the first strain sensor inside grating separation  $DA-\delta$  791 and the second strain sensor grating separation  $DB-\delta$  795 are both less than before. This in combination with the out side being stretched creating larger separation  $DA+\delta$  793,  $DB+\delta$  797, will create a varying separation across the fiber. This will create, as can be seen in fig. 7B, wide frequency responses 779 instead of peaks at the center frequencies 771, 772.

Figure 8A shows a bent optical fiber 890 with Bragg grating arranged in a first 851 and second 852 strain sensor, according to the invention. An optical fiber with Bragg grating according to the invention, will have an equal grating separation DA 892, DB 896 through the fiber, when the fiber is bent, such as around a circular bearing. As can be seen in fig. 8B, we achieve the desired peak frequency responses 871, 872, when the fiber is bent. The grating could be added after mounting of the fiber on the bearing.

The invention is not restricted to the above-described embodiments, but may be varied within the scope of the following claims.

NL10111 SPB

26 NOVEMBER 2010

FIGURE 1 shows a side view of a bearing in a housing, a typical  
5 implementation of the invention,

- 110 Bearing,
- 112 Outer, non-rotating, ring of the bearing,
- 114 Inner, rotating, ring of the bearing,
- 116 Rolling elements of the bearing, located between the outer and  
10 inner ring,
- 120 Housing.

FIGURE 2 shows a cross section of a part of a bearing according to one  
embodiment according to the invention,

- 15 212 First outer ring belonging to the first row,
- 213 Second outer ring belonging to the second row,
- 216 Rolling elements of first row,
- 217 Rolling elements of second row,
- 230 First groove for first row,
- 20 231 Second groove for second row,
- 234 Height/Depth of groove,
- 235 Width of groove,
- 237 Load line of first row,
- 238 First optical fiber slit located in first groove,
- 25 239 Second optical fiber slit located in second groove,

FIGURE 3 shows a cross section of a part of a bearing according to another  
embodiment according to the invention,

- 312 Outer ring,
- 30 316 Rolling elements,
- 330 First groove,
- 331 Second groove,

332 Third groove,

FIGURE 4 shows a top view of a bearing according to the invention illustrating optical fiber access to measurement groove.

5 412 Outer ring,

430 First groove,

431 Second groove,

440 Optical fiber passage for entry/exit.

10 FIGURE 5A shows a side sectional view of a bearing according to the invention illustrating an example of sensor distribution according to the invention around the bearing,

500 Bearing according to the invention with a optical fiber strain sensor unit,

15 512 Outer, non-rotating, ring of the bearing,

514 Inner, rotating, ring of the bearing,

516 Rolling elements of the bearing, located between the outer and inner ring,

550 Optical fiber strain sensor unit,

20 551 SA - strain sensor,

552 SB - strain sensor,

553 SC - strain sensor,

554 SD - strain sensor,

555 SE - strain sensor,

25 556 SF - strain sensor,

557 SG - strain sensor,

558 SH - strain sensor,

560 Unloaded zone of bearing,

562 Loaded zone of bearing.

30

FIGURE 5B shows the sensor frequency distribution according to the sensor placement of fig. 5A,

- 571 fA center frequency of SA - strain sensor,  
 572 fB center frequency of SB - strain sensor,  
 573 fC center frequency of SC - strain sensor,  
 574 fD center frequency of SD - strain sensor,  
 5 575 fE center frequency of SE - strain sensor,  
 576 fF center frequency of SF - strain sensor,  
 577 fG center frequency of SG - strain sensor,  
 578 fH center frequency of SH - strain sensor,  
 580 Large frequency variation due to large load variations  
 10 582 Medium frequency variation due to medium load variations  
 584 Small frequency variation due to large small variations

FIGURE 6A shows a conventional optical fiber with Bragg grating, arranged flat,

- 15 651 First strain sensor,  
 652 Second first strain sensor,  
 690 Optical fiber sensor unit with Bragg grating  
 692 First strain sensor grating separation DA,  
 696 Second strain sensor grating separation DB,

20

FIGURE 6B shows the frequency response of the optical fiber of fig. 6A,

- 671 Frequency response of first strain sensor,  
 672 Frequency response of second strain sensor,

25 FIGURE 7A shows a conventional optical fiber with Bragg grating that is bent, such as around a circular bearing,

- 751 First strain sensor,  
 752 Second first strain sensor,  
 790 Optical fiber sensor unit with Bragg grating  
 30 791 First strain sensor inside grating separation DA- $\delta$ ,  
 793 First strain sensor outside grating separation DA+ $\delta$ ,  
 795 Second strain sensor grating separation DB- $\delta$ ,

797 Second strain sensor grating separation  $DB+\delta$ ,

FIGURE 7B shows the frequency response of the bent optical fiber of fig. 7A,

771 Center frequency response of first strain sensor,

5 772 Center frequency response of second strain sensor,

779 Frequency width.

FIGURE 8A shows a bent optical fiber with Bragg grating according to the invention,

10 851 First strain sensor,

852 Second first strain sensor,

890 Optical fiber sensor unit with Bragg grating

892 First strain sensor outside and inside grating separation  $DA$ ,

896 Second strain sensor outside and inside grating separation  $DB$ ,

15

FIGURE 8B shows the frequency response of the optical fiber according to the invention of fig. 8A,

871 Frequency response of first strain sensor,

872 Frequency response of second strain sensor,

20

## CLAIMS

5

1. A bearing comprising a Bragg grating optical fiber for measuring one or more parameters of the bearing, the Bragg grating optical fiber is attached to the bearing such that a grating of the optical fiber is curved,  
10 characterized in that the grating of the Bragg grating optical fiber is adapted to the curvature in such a way that the influence on the frequency response due to the curvature is minimized.
2. The bearing according to claim 1, characterized in that the gratings of the  
15 grating are substantially parallel when the optical fiber grating is curved.
3. The bearing according to claim 1 or 2, characterized in that the gratings are made before the optical fiber is attached to the bearing, and the gratings are made such that when the expected curvature of the optical  
20 fiber is done, the gratings are substantially parallel.
4. The bearing according to claim 1 or 2, characterized in that the gratings are made when the optical fiber is attached to the bearing, the gratings being made such that they are substantially parallel when the optical fiber  
25 is mounted.
5. The bearing according to any one of the previous claims, characterized in that the optical fiber has at least one flat surface, a non-circular cross section, to be able to define the orientation of the optical fiber and thereby  
30 attach the fiber to the bearing in a predetermined orientation.

1/6

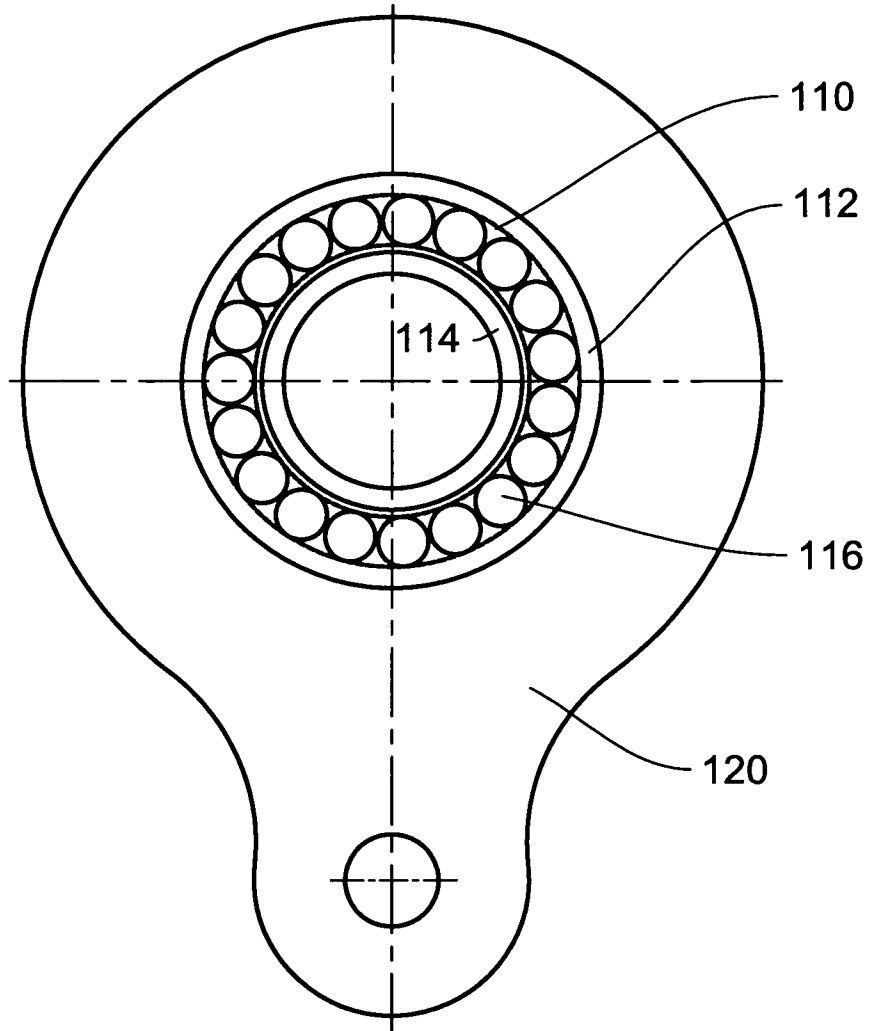

FIG 1

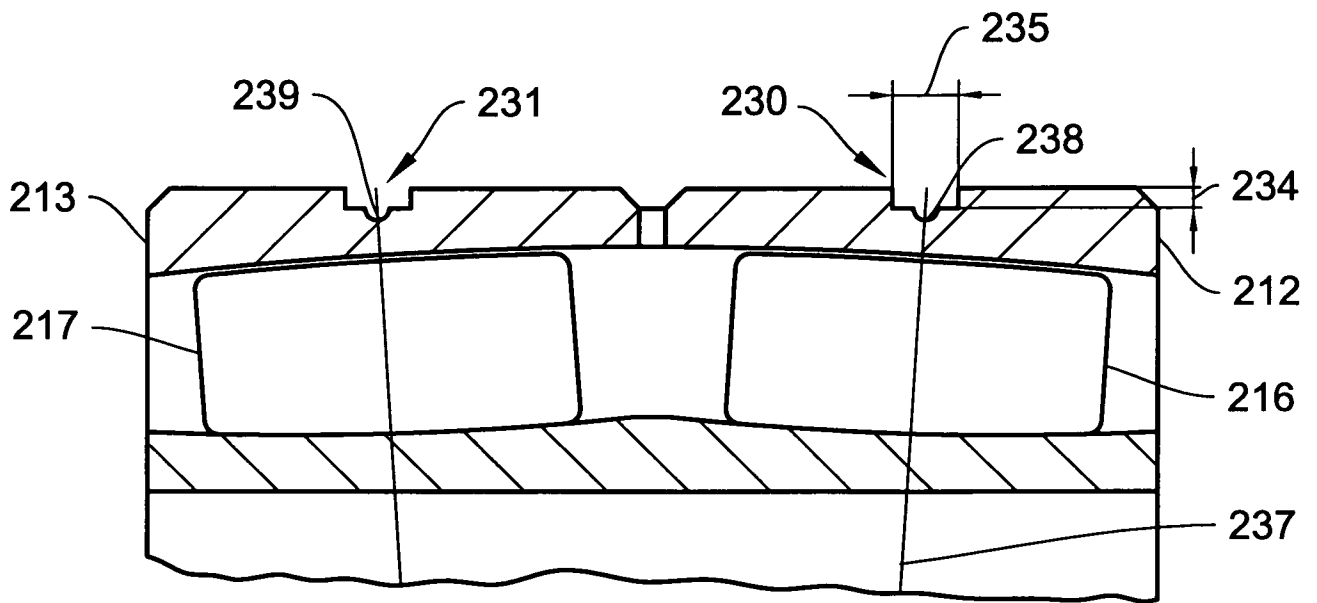

FIG 2

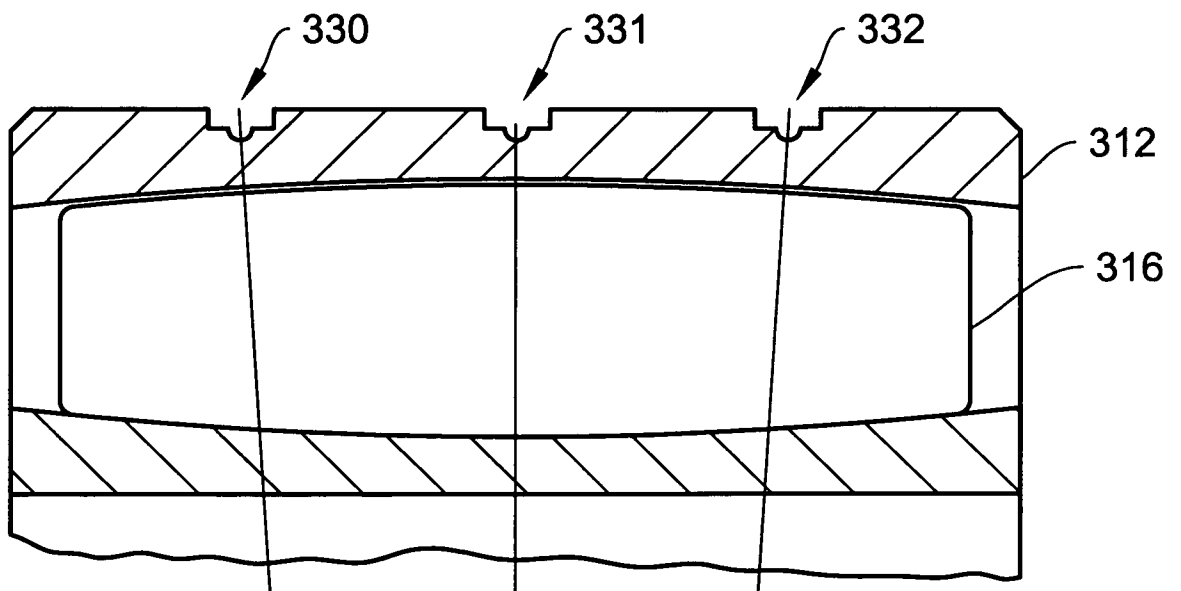

FIG 3

3/6

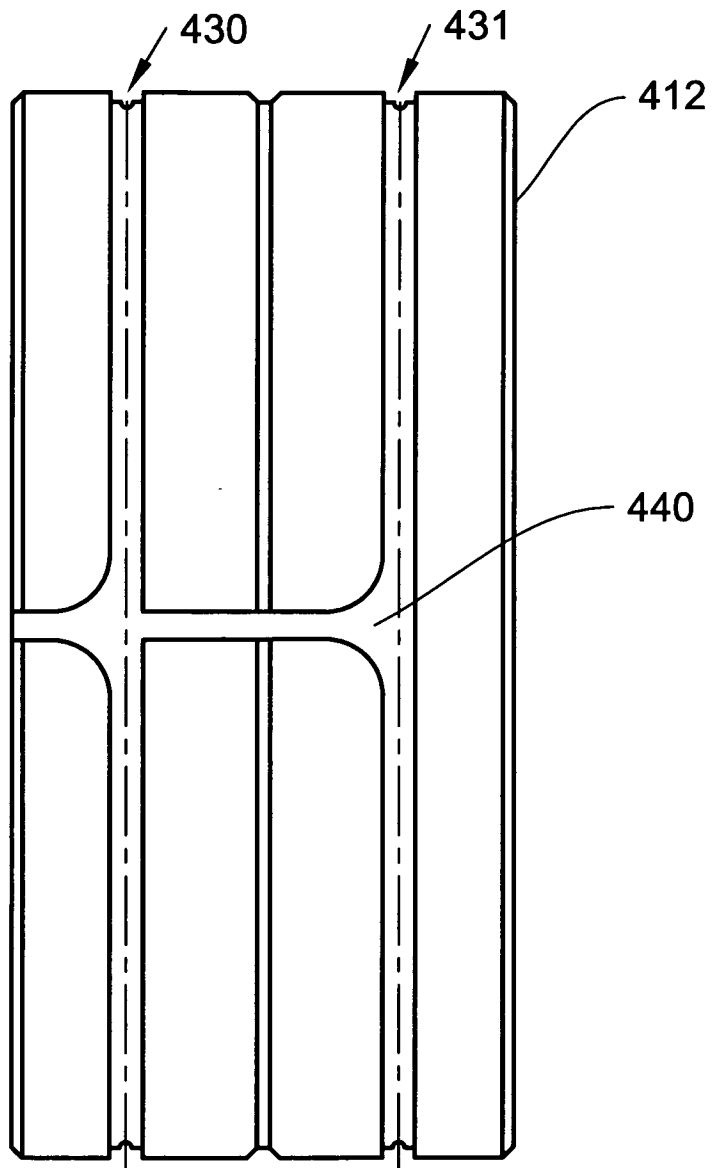

FIG 4

4/6

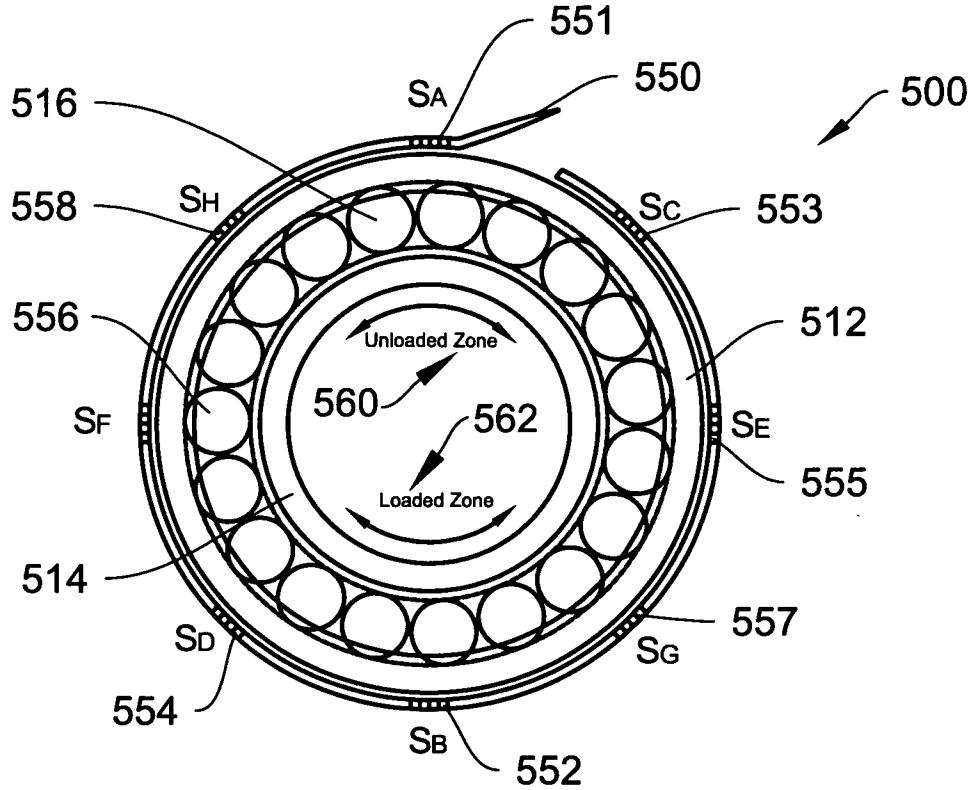

FIG 5A

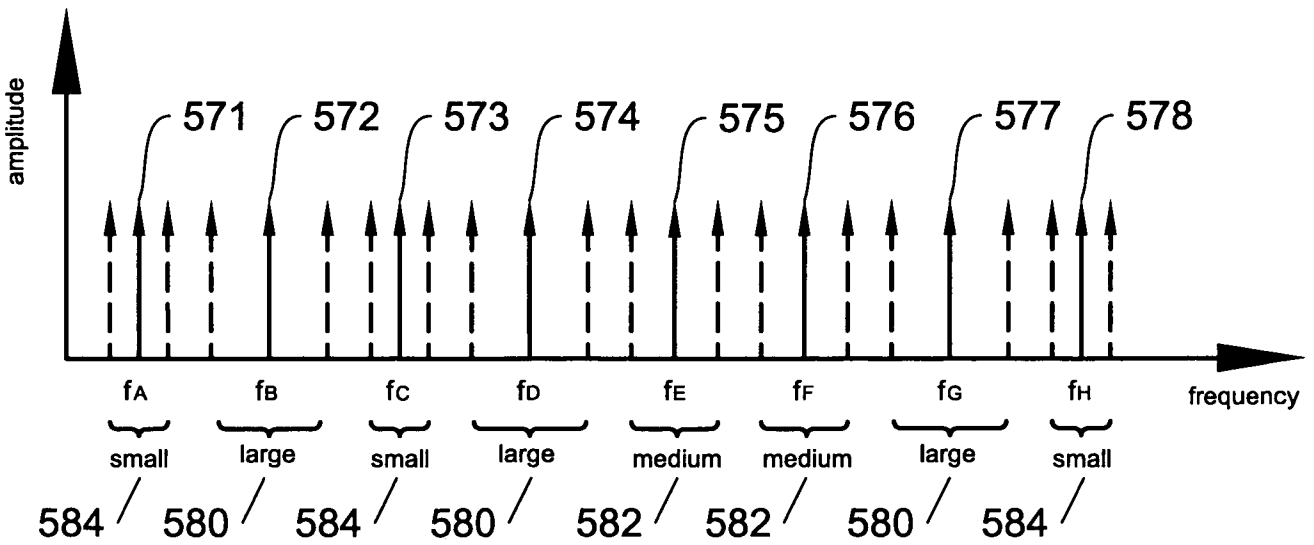
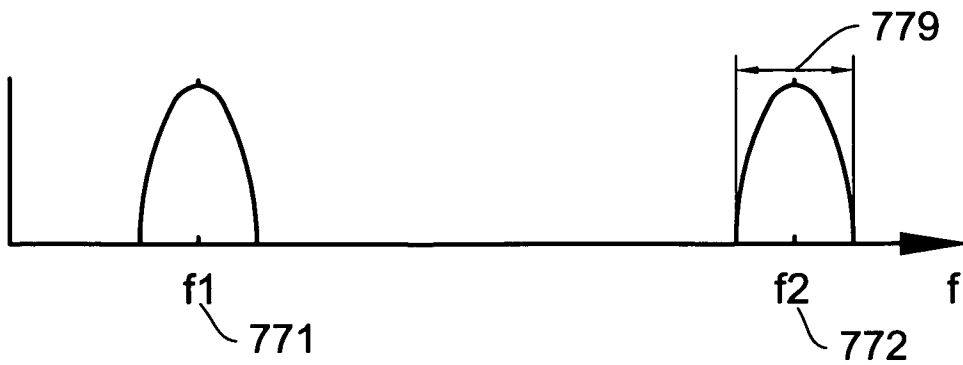
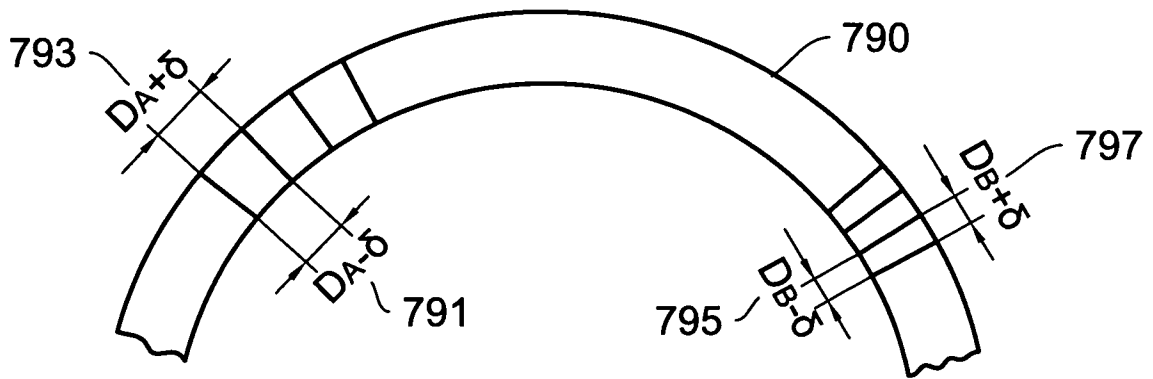
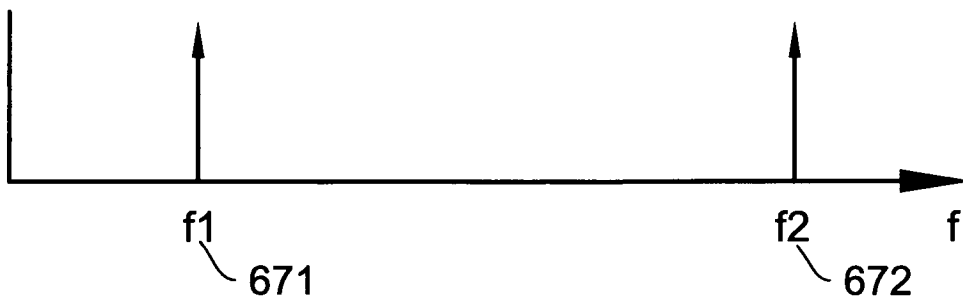
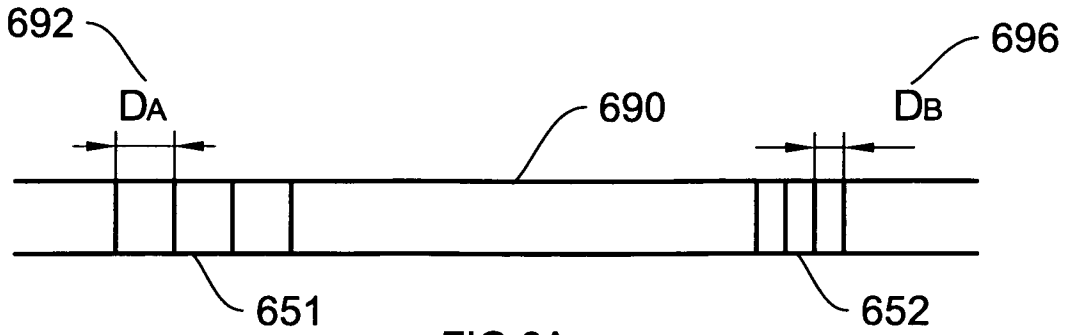

FIG 5B



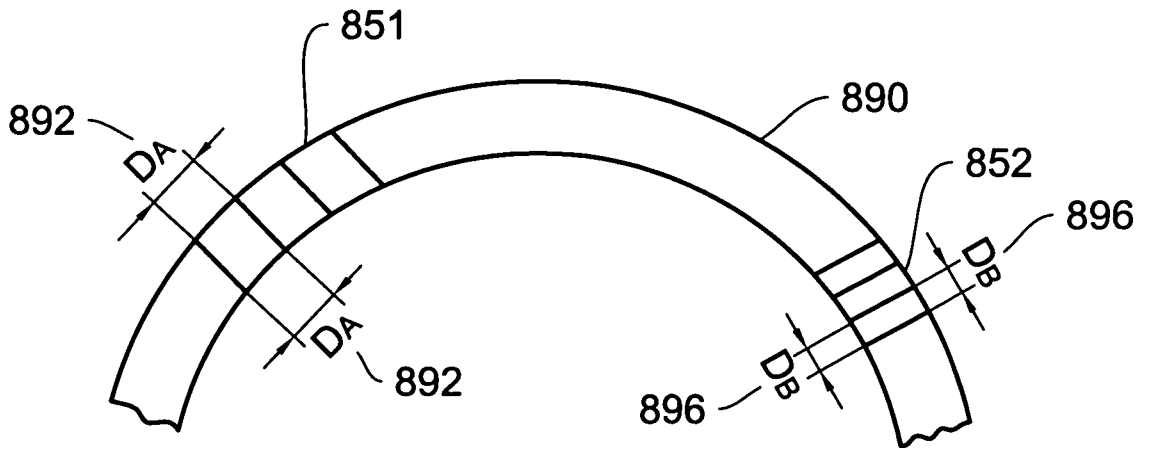

FIG 8A

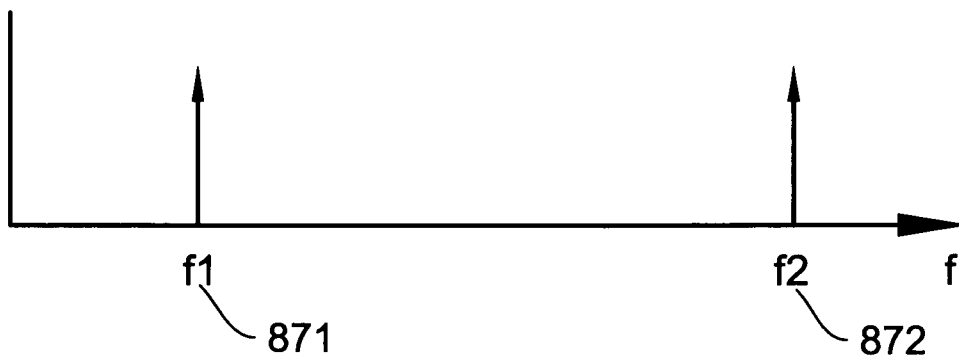

FIG 8B

**INTERNATIONAL SEARCH REPORT**

International application No  
PCT/EP2010/007190

A. CLASSIFICATION OF SUBJECT MATTER  
INV. G01L1/24 G01L5/00 G01D5/353 G01M13/04  
ADD.  
According to International Patent Classification (IPC) or to both national classification and IPC

B. FIELDS SEARCHED  
Minimum documentation searched (classification system followed by classification symbols)  
G01L G01B G01D G01M F16C G02B  
Documentation searched other than minimum documentation to the extent that such documents are included in the fields searched

Electronic data base consulted during the international search (name of data base and, where practical, search terms used)  
EPO-Internal, INSPEC, COMPENDEX

C. DOCUMENTS CONSIDERED TO BE RELEVANT

Category*	Citation of document, with indication, where appropriate, of the relevant passages	Relevant to claim No.
A	HOFFMANN L ET AL: "Fiber optic strain measurement for machine monitoring", PROCEEDINGS OF THE SPIE - THE INTERNATIONAL SOCIETY FOR OPTICAL ENGINEERING SPIE - THE INTERNATIONAL SOCIETY FOR OPTICAL ENGINEERING USA, vol. 6616, 2007, XP002617620, ISSN: 0277-786X the whole document	1-5
A	US 2004/083808 A1 (RAMBOW FREDERICK HENRY KREISLE [US] ET AL) 6 May 2004 (2004-05-06) paragraphs [0045] - [0049], [0 58] - [0070]; figures 1,2,3b ----- -/--	1-5

Further documents are listed in the continuation of Box C.

See patent family annex.

\* Special categories of cited documents :

- "A" document defining the general state of the art which is not considered to be of particular relevance
- "E" earlier document but published on or after the international filing date
- "L" document which may throw doubts on priority claim(s) or which is cited to establish the publication date of another citation or other special reason (as specified)
- "O" document referring to an oral disclosure, use, exhibition or other means
- "P" document published prior to the international filing date but later than the priority date claimed

- "T" later document published after the international filing date or priority date and not in conflict with the application but cited to understand the principle or theory underlying the invention
- "X" document of particular relevance; the claimed invention cannot be considered novel or cannot be considered to involve an inventive step when the document is taken alone
- "Y" document of particular relevance; the claimed invention cannot be considered to involve an inventive step when the document is combined with one or more other such documents, such combination being obvious to a person skilled in the art.
- "&" document member of the same patent family

Date of the actual completion of the international search  25 January 2011	Date of mailing of the international search report  09/02/2011
Name and mailing address of the ISA/ European Patent Office, P.B. 5818 Patentlaan 2 NL - 2280 HV Rijswijk Tel. (+31-70) 340-2040, Fax: (+31-70) 340-3016	Authorized officer  Debesset, Sébastien

## INTERNATIONAL SEARCH REPORT

International application No  
PCT/EP2010/007190

C(Continuation). DOCUMENTS CONSIDERED TO BE RELEVANT		
Category*	Citation of document, with indication, where appropriate, of the relevant passages	Relevant to claim No.
A	US 5 787 213 A (BROWNLOW DARRYL LENEIR [US]) 28 July 1998 (1998-07-28) column 1, lines 33-67; figure 2 -----	1-5
A	L. D'acquisto, R.Montanini: "On the behaviour of in-fibre bragg grating sensors for strain measurement on plane and curved surfaces", XVII IMEKO World Congress Metrology in the 3rd Millennium, 27 June 2003 (2003-06-27), XP002618240, Dubrovnik, Croatia Retrieved from the Internet: URL: <a href="http://www.imeko.org/publications/wc-2003/PWC-2003-TC2-007.pdf">http://www.imeko.org/publications/wc-2003/PWC-2003-TC2-007.pdf</a> [retrieved on 2011-01-25] the whole document -----	1-5

# INTERNATIONAL SEARCH REPORT

Information on patent family members

International application No

PCT/EP2010/007190

Patent document cited in search report	Publication date	Patent family member(s)	Publication date
US 2004083808	A1	06-05-2004	NONE
-----			
US 5787213	A	28-07-1998	NONE
-----			