

C. H. CROWELL.

MACHINE FOR APPLYING EDGE COVERING STRIPS TO TABLETS.

(Application filed Mar. 25, 1898.)

(No Model.)

2 Sheets—Sheet 1.

Fig. 1.

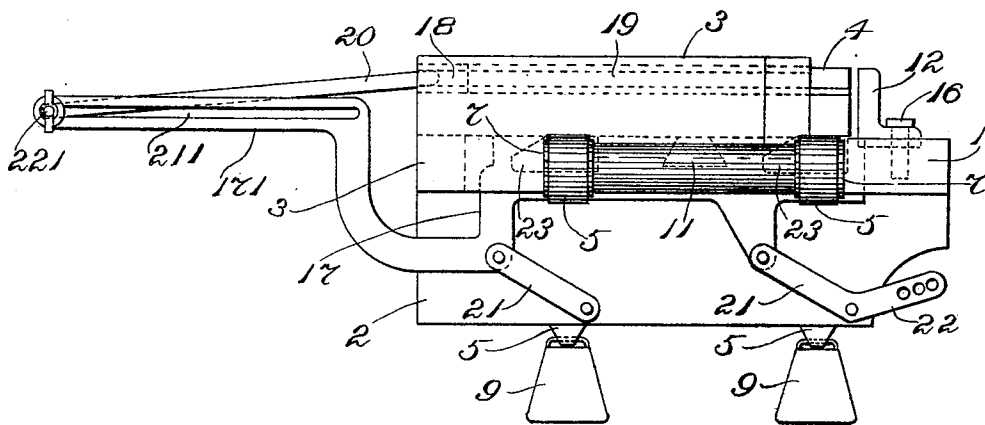
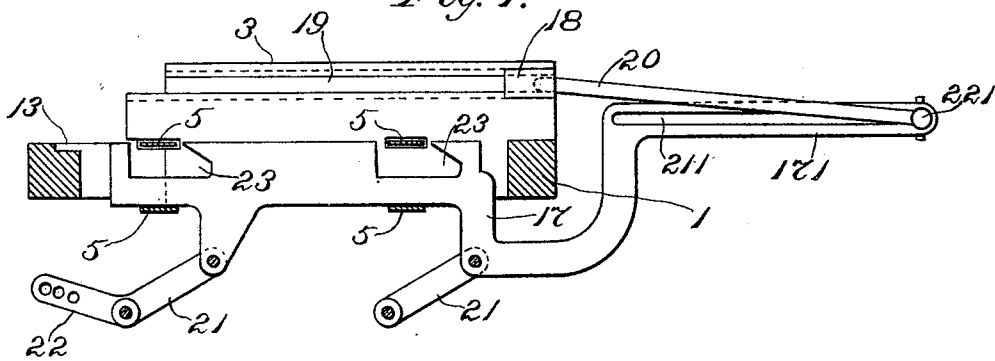

Fig. 4.



Witnesses:

Oscar F. Hill
Edith J. Anderson.

Inventor:

Charles H. Crowell
by Maceo Calver & Randall
Attorneys.

C. H. CROWELL.

MACHINE FOR APPLYING EDGE COVERING STRIPS TO TABLETS.

(Application filed Mar. 25, 1898.)

(No Model.)

2 Sheets—Sheet 2

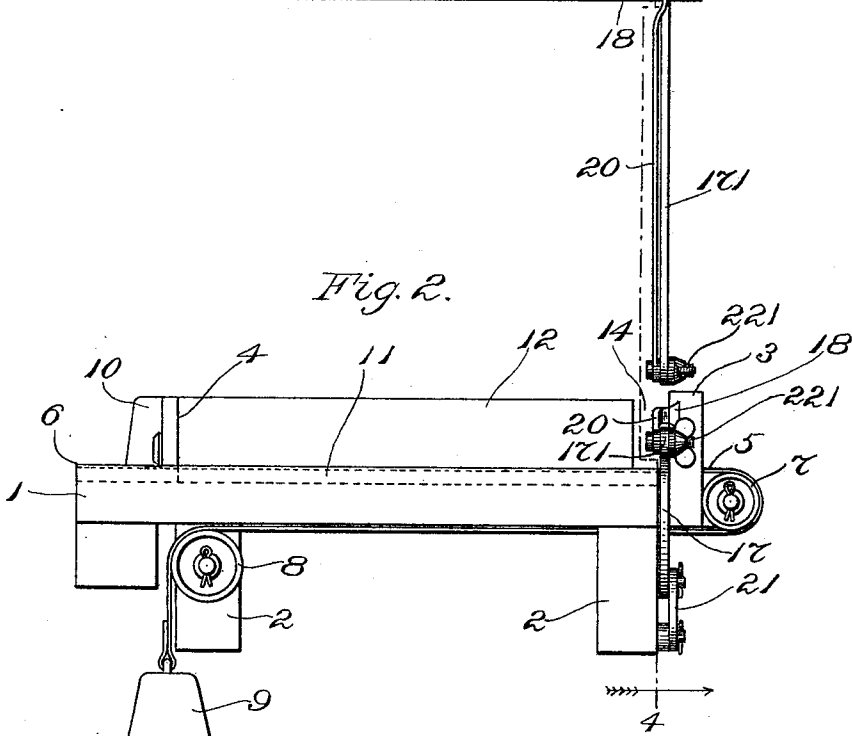
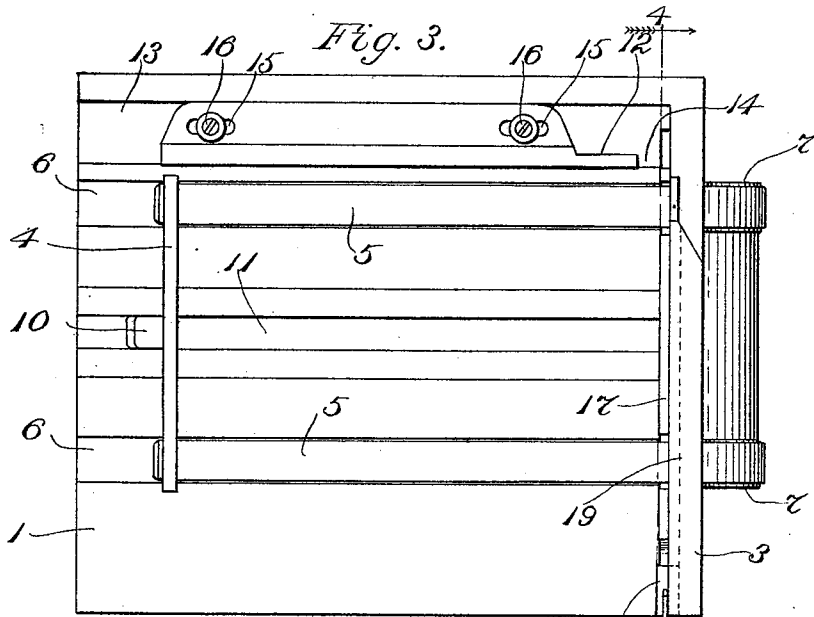

Witnesses:

Oscar F. Hill
Edith J. Anderson.

Inventor:

Charles H. Crowell
by Maceo Baker & Randall
Attorneys.

UNITED STATES PATENT OFFICE.

CHARLES H. CROWELL, OF LYNN, MASSACHUSETTS, ASSIGNOR TO THE
CARTER, RICE & COMPANY, OF BOSTON, MASSACHUSETTS.

MACHINE FOR APPLYING EDGE-COVERING STRIPS TO TABLETS.

SPECIFICATION forming part of Letters Patent No. 619,870, dated February 21, 1899.

Application filed March 25, 1898. Serial No. 675,059. (No model.)

To all whom it may concern:

Be it known that I, CHARLES H. CROWELL, a citizen of the United States, residing at Lynn, in the county of Essex and State of Massachusetts, have invented certain new and useful Improvements in Machines for Applying Edge-Covering Strips to Memorandum-Tablets, &c., of which the following is a specification, reference being had therein to the accompanying drawings.

In the manufacture of memorandum-tablets and the like articles a number of sheets of paper are assembled together until a mass of the required quantity is produced. The assembled sheets then are treated with adhesive material along the edges of one side and one end in order to bind them together for use; but, as is well known, the adhesive material is applied in such manner as to permit the sheets to be separated from one another readily by hand as required in the use thereof. To the edges which thus have been treated with the adhesive material it is customary to apply a covering-strip of paper for purposes of ornamentation or finish. This strip is of sufficient width to cover the edge of the tablet and lap around slightly upon the face and back sheets of the tablet, and it is equal in length to the combined length of the two edges of the tablet to which the adhesive material has been applied. In applying the strip the work is performed by hand, the strip, after first having been treated with gum, glue, or paste, being laid in place upon the proper edges of the tablet and pressed down so as to adhere smoothly to the said edges and the adjacent portions of the face and back sheets of the tablet.

The object of the invention is to provide a machine of convenient and serviceable character which shall facilitate the work of applying covering and finishing strips as aforesaid, and likewise be fitted for use in other connections in which its functions and mode of operation are capable of being utilized.

The invention consists in the machine of novel and useful character and construction which I now shall proceed to describe with particular reference to the accompanying drawings, in which latter I have illustrated

the best embodiment of the invention which I have yet contrived.

In the drawings, Figure 1 shows the said embodiment in end elevation looking from the right in Figs. 2 and 3. Fig. 2 is a view of the machine in side elevation. Fig. 3 is a view thereof in plan. Fig. 4 is a view in section on the plane which is indicated by the dotted line 4 4 in Figs. 2 and 3, looking in the direction that is indicated by the arrows at the ends of such line.

1 designates a table, and 2 2 designate supports upon which the said table is mounted. Any suitable form of supports may be adopted in practice.

3 designates an end piece or stop rising above the level of the upper surface of the table 1 and extending transversely of the said table at or adjacent to one end thereof.

4 is a movable follower occupying a position parallel with the raised end piece or stop 3 and made capable of being advanced toward and moved away from the said end piece or stop. With the said follower 4 I combine means whereby to press it in a yielding manner toward the end piece or stop 3. It is intended that a number of tablets which have had the edges thereof treated with adhesive material, as aforesaid, and which are in readiness to have applied to such edges covering and finishing strips of the character which has been indicated hereinabove, shall be placed together side by side and standing on edge upon the upper surface of table 1, between the follower 4 and the raised end piece or stop 3, and parallel with the two latter. The follower acts to compress the series of tablets between itself and the end piece or stop and to hold the tablet which is next adjacent to the said end piece or stop pressed closely against the surface of the latter; also when such tablet is withdrawn from the machine the follower acts to advance the series of tablets until the next tablet in order is pressed against the end piece or stop. Various approved means of advancing the follower in a yielding manner may be adopted. I have employed by preference the arrangement that is shown in the drawings, the same comprising bands or tapes 5 5, which are con-

nected with the said follower, as shown, and
 pass thence within shallow grooves 6 6, extend-
 ing lengthwise of the table to and around
 guides or pulleys 7 7 at the right-hand end
 5 of the machine adjacent to the raised end
 piece or stop 3. The tapes or bands 5 5 may
 hang vertically downward from the guides or
 pulleys 7 7; but I find it advantageous to lead
 them inwardly from said guides or pulleys
 10 to and around other guides or pulleys 8 8,
 weights, as 9 9, being attached to the depend-
 ing portions of the tapes or bands 5 5. The
 shallow grooves 6 6 are provided to receive
 the portions of said tapes or bands that ex-
 15 tend along the top of table 1, so that the said
 tapes or bands shall not become clamped and
 held between the tablets and the surface of
 the table. The number of tapes or bands
 may vary. To guide the follower in its move-
 20 ments and prevent it from rising out of place,
 I provide the same with a foot, as 10, of dove-
 tail shape in cross-section, fitting a dovetail
 groove 11 (see Figs. 1 and 3) in the upper
 25 side of table 1, the said groove extending
 lengthwise of the said table. In order to
 aline properly the series of tablets, I provide
 a side guide, as 12, located adjacent to one
 edge of the table 1 and extending lengthwise
 30 to the end piece or stop 3—the foot portion of
 the said side guide being received in a groove
 or depression 13 in the upper side of the
 table 1. When the tablets are placed on the
 table between the end piece or stop 3 and
 35 the follower 4, their glued or cemented side
 edges are turned uppermost and their glued or
 cemented ends are turned toward and pushed
 into contact with the inner vertical face of
 guide 12. The side guide 12 does not extend
 40 along quite as far as the inner vertical face
 of end piece or stop 3, but terminates short
 thereof, leaving a gap or opening 14 to per-
 mit the tablet resting in contact with the said
 end piece or stop 3 to be pushed endwise—
 45 that is to say, in a direction parallel with end
 piece or stop 3—into and partly through the
 said gap or opening. In order to meet the
 varying requirements of use, the side guide
 50 12 is made adjustable lengthwise, as by means
 of slots 15 15, receiving the stems of the hold-
 ing screws or bolts 16 16. (See Fig. 3.)

In order to give facility in applying the cover-
 ing and finishing strip to the foremost tablet
 of the series on table 1, the said tablet being
 55 the one which is pressed into contact with
 end piece or stop 3, I provide for causing the
 said tablet to be uplifted slightly relatively
 to the rest of the series and also pushed end-
 wise partly through the gap or opening 14.
 60 This will project its glued or cemented edges
 into prominent positions and render them
 accessible to the operator. I effect this au-
 tomatically by means of the devices which I
 now shall describe. Thus 17 designates a
 65 slide consisting of a thin strip or plate, as
 shown, and mounted to move in a vertical
 plane closely adjacent to the end piece or

stop 3. When this slide is elevated, it up-
 raises to the required extent the tablet which
 is in contact with the said end piece or stop. 70
 When the slide is depressed, the removal of
 the said tablet allows the series of tablets to
 be advanced by the action of the movable
 follower, so as to bring the next tablet of
 such series into contact with the end piece or 75
 stop and above the slide 17.

18 is what may be designated herein for
 convenience a "pusher." It is of dovetail
 shape in cross-section and fits a dovetail
 groove 19, extending lengthwise of the end 80
 piece or stop 3, as shown in dotted lines in
 Fig. 1. This pusher is moved along the said
 groove to project the foremost tablet endwise
 into and partly through the gap or opening
 14 adjacent to the end of side guide 12. For 85
 convenience and simplicity I usually connect
 the said pusher with the slide 17, and I com-
 municate to the said slide a movement hav-
 ing both a vertical component and a horizon-
 tal component, whereby as the slide rises and 90
 falls in lifting a tablet and resuming its low-
 ered position it also moves endwise, carrying
 the pusher endwise, so as to project the tab-
 let endwise also and afterward retract the
 95 pusher. In the present case I have illustrated
 the pusher as connected by a link 20 to an
 arm or extension 171 of the slide, and the
 slide is mounted upon links or arms 21 21,
 which latter are connected pivotally to the
 said slide and also to one of the supports 2. 100
 One of the said links or arms 21 is furnished
 with an extension, as 22, Fig. 1, to which
 power may be applied or transmitted in known
 manner.

In operation the extension 22 is depressed 105
 by power transmitted or applied thereto, which
 operates to carry the slide 17 upwardly and
 also endwise, thereby partially uplifting the
 foremost tablet. The endwise component of
 the movement of the slide occasions the hori- 110
 zontal advancing movement of the pusher 18,
 thereby effecting the partial endwise move-
 ment of the said tablet, and thereby the edges
 of the foremost tablets, which are to receive
 the covering and finishing strip are given suffi- 115
 cient prominence and clearance from the re-
 maining tablets to enable the strip to be ap-
 plied and smoothed down conveniently and
 readily. When the pressure or strain upon
 extension 22 is relieved, the slide 17 drops 120
 back into its original position, carrying the
 pusher back into retracted position also. (See
 Fig. 1.)

In order to provide for handling different
 sizes of tablets, the pusher 18 is made adjust- 125
 able with reference to the length of the end
 piece or stop 3. Thus the point of connec-
 tion of link 20 with arm or extension 171 of
 slide 17 is made capable of being varied along
 said arm or extension, as by forming in the 130
 arm or extension the longitudinal slot 21 and
 adjusting to various points in said slot the
 bolt 22, which serves to connect the said link
 to the arm.

23 23, Fig. 1, are openings made in the slide 17 to enable the latter to clear the tapes or bands 5 5 in the movements of the slide.

5 As will be apparent, the machine is not limited necessarily to use in applying covering or finishing strips to the edges of memorandum-tablets, although it was designed primarily for such use.

10 I do not in all cases restrict myself to the particular construction and arrangement of parts which I have herein shown and described, for the same may be modified in various respects by the adoption of equivalents without involving any departure from the principles of the invention.

15 I claim as my invention—

1. The improved machine comprising the table, the end piece or stop, the movable follower and means to carry it toward the said end piece or stop, the side guide, and devices for elevating and moving endwise the tablet which is next adjacent the said end piece or stop, to expose the upper edge and advanced end thereof to the operator.

25 2. The improved machine comprising the table, the end piece or stop, the movable fol-

lower and means to carry it toward the said end piece or stop, the side guide, the slide to elevate the foremost tablet, the pusher to move the said tablet endwise, and means to actuate the said slide and pusher. 30

3. The improved machine comprising the table, the end piece or stop, the movable follower and means to carry it toward the said end piece or stop, the slide, the pusher connected therewith, and means to communicate to said slide a movement both upward and endwise. 35

4. The improved machine comprising the table, the end piece or stop, the movable follower and means to carry it toward the said end piece or stop, the slide, the pusher connected therewith, and the links or arms connecting said slide with a fixed part of the machine and serving to occasion a movement of said slide both upward and endwise. 40 45

In testimony whereof I affix my signature in the presence of two witnesses.

CHARLES H. CROWELL.

Witnesses:

CHAS. F. RANDALL,

WILLIAM A. COPELAND.