

(No Model.)

G. E. MAYHEW.
YARN GUIDE FOR SPOOLING FRAMES.

No. 522,378.

Patented July 3, 1894.

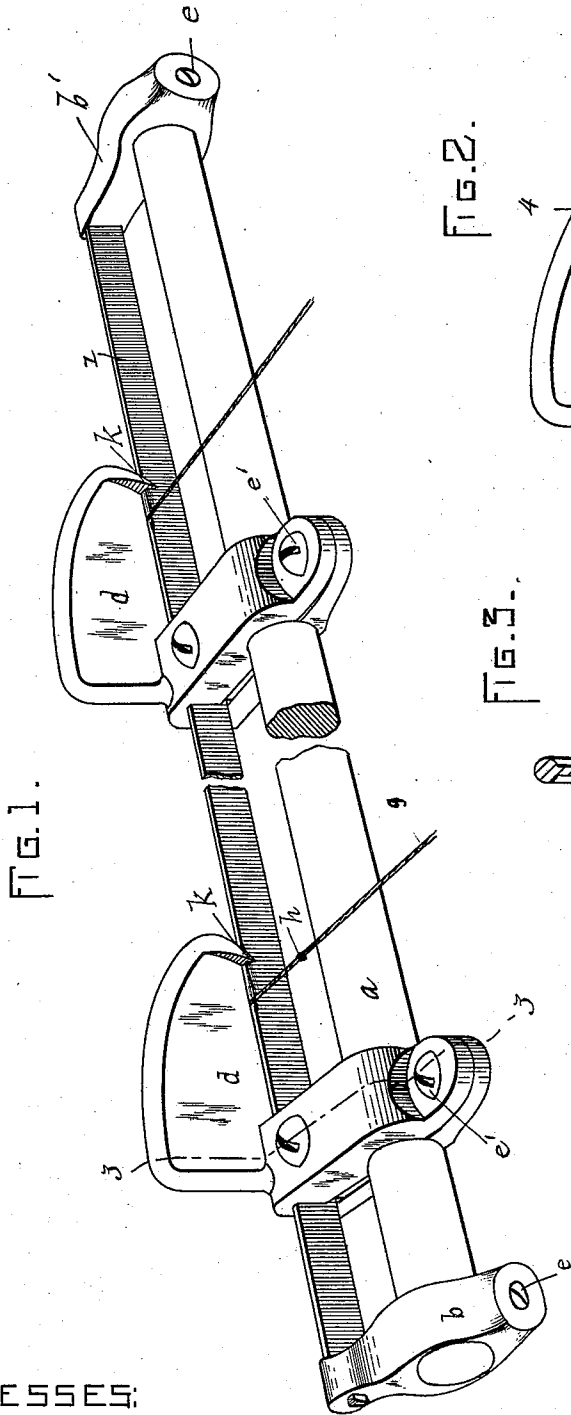

FIG. 2.

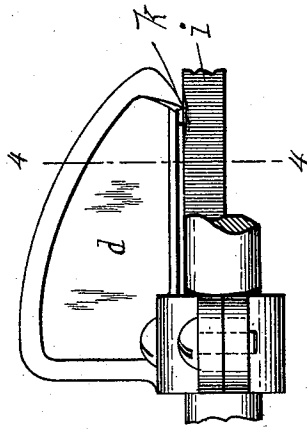

FIG. 3.

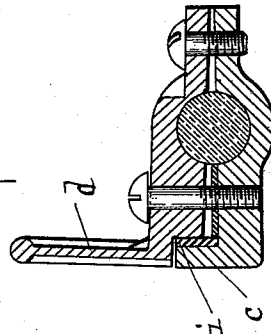
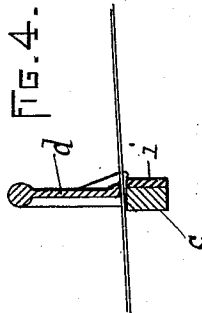

FIG. 4.



WITNESSES:

H. A. Hall.
W. S. Mead.

INVENTOR:

Geo. E. Mayhew
by
Wm. Brown Crossley
Att'y.

UNITED STATES PATENT OFFICE.

GEORGE E. MAYHEW, OF MANCHESTER, NEW HAMPSHIRE.

YARN-GUIDE FOR SPOOLING-FRAMES.

SPECIFICATION forming part of Letters Patent No. 522,378, dated July 3, 1894.

Application filed December 15, 1892. Serial No. 455,291. (No model.)

To all whom it may concern:

Be it known that I, GEORGE E. MAYHEW, of Manchester, in the county of Hillsborough and State of New Hampshire, have invented certain new and useful Improvements in Yarn-Guides for Spooler-Frames, of which the following is a specification.

This invention has relation to yarn guides and clearers for spooler frames; and it has for its object the provision of means whereby all the guides of a frame may be kept in line, and whereby the ends may be kept from dropping down between and being drawn under the guides and wound around the spindles of the spool, and so causing serious waste.

To these ends the invention consists in providing a bar which extends through and supports a plurality of guides, the said bar being itself supported at each of its ends on adjustable brackets or equivalent means, all as I will now proceed to describe and claim.

Reference is to be had to the annexed drawings and to the letters marked thereon, forming a part of this specification, the same letters designating the same parts or features, as the case may be, wherever they occur.

Of the drawings—Figure 1, is a perspective view of the invention, the two end guides only of a series being shown, it being understood that, say fifty guides are employed in a full frame, and that those intermediate of the end guides are broken out. Fig. 2, is a rear or back view of one of the guides and its immediately-connected parts. Fig. 3, is a cross section taken on the line 3 3 of Fig. 1. Fig. 4, is a cross section taken on the line 4 4 of Fig. 2.

In the drawings, *a* designates the rod or bar, to which are attached the brackets *b b'* constituting the bases or supports for the guides and clearers, which are usually composed of cast iron.

Each guide and clearer consists of a base bar *c* and a top bar or piece *d* both extending parallel with the rod *a* to which are attached the bracket or supporting parts *b b'*, which latter parts may be secured to the supporting rod *a* by means of clamping screws *e*.

The lower or base bar *c* and upper or top piece or bar *d* of each guide are so adjusted as to leave a space between the two just sufficiently wide for the yarn *g* when of normal size, to pass without obstruction, but so that

the yarn will be freed from or cleared of burls, bunches, fluffs or knots *h*.

i designates a bar, which may be made of wrought iron or other suitable material, and which is supported at its ends in the ends of brackets *b* adjustably connected with the rod or supporting bar *a*. The said bar *i* may be flat, round, or square, or of other desired form, and extends through all of the guides of the series in a frame between the supporting bracket parts *b b'* which are suitably grooved or otherwise formed to receive the same.

By means of the bar *i* I am enabled to set or adjust all of the guides of a series as to maintain the same in the same horizontal line, and in case a yarn breaks or leaves the guide it is prevented by the portion of the bar extending between each two guides from dropping down between and getting under the same so as to become wound on the spindle of its spool, and so causing waste yarn, a thing very likely to occur with present constructions where no such thing as the supporting bar *i* is provided.

k designates a spur on the outer end of the top piece *d* of the guide which projects down upon a beveled or cut-away point of the bar *i*, so as to prevent the yarn from accidentally running or being purposely thrown out from between the guide and clearing parts *c d*, the said spur serving the purpose of the gravitating gate employed in the guides and clearers of common construction.

By my invention much time is saved in adjusting the guides in proper uniform line, and a material saving is effected in the wastage of yarn, as before explained.

It is obvious that the bar *i* may be made to serve as the lower portion or bar of each guide, and be adjusted by means of the adjusting screw *e* passing through the two brackets or supporting parts *b b'* whereby said parts are adjustable circumferentially on the rod as is now done to support and adjust the two parts of each guide.

Having thus explained the nature of the invention and described a way of constructing and using the same, though without attempting to set forth all of the forms in which it may be made or all of the modes of its use, it is declared that what is claimed is—

1. A plurality of yarn guides and clearers, a supporting rod *a* for the same, and an aligning bar *i* supported at its ends from said rod *a*, and extending through all of the guides of
5 the series, as set forth.

2. A series of yarn guides and clearers and a bar passing through the same, a supporting rod, and brackets adjustably connected with the said rod, the said bar being supported at
10 its ends by the said brackets, as set forth.

3. A plurality of yarn guides and clearers, a bar extending through all of the guides of the series and beveled or cut away at points,

a spur on the end of one part of each guide extending into the said cut-away or beveled
15 point, a supporting rod, and brackets connected with said rod and bar as set forth.

In testimony whereof I have signed my name to this specification in, the presence of two subscribing witnesses, this 10th day of
20 December, A. D. 1892.

GEORGE E. MAYHEW.

Witnesses:

HARRY T. LORD,
HIRAM FORSAITH.