



- (51) **International Patent Classification:**  
H04L 25/49 (2006.01) H04L 25/02 (2006.01)  
H04L 25/493 (2006.01)
- (21) **International Application Number:**  
PCT/US2014/021979
- (22) **International Filing Date:**  
7 March 2014 (07.03.2014)
- (25) **Filing Language:** English
- (26) **Publication Language:** English
- (30) **Priority Data:**

61/774,408	7 March 2013 (07.03.2013)	US
61/774,247	7 March 2013 (07.03.2013)	US
61/778,768	13 March 2013 (13.03.2013)	US
14/199,898	6 March 2014 (06.03.2014)	US
- (71) **Applicant: QUALCOMM INCORPORATED** [US/US];  
ATTN: International IP Administration, 5775 Morehouse Drive, San Diego, California 92121-1714 (US).
- (72) **Inventors: SENGOKU, Shoichiro**; 5775 Morehouse Drive, San Diego, California 92121-1714 (US). **WILEY, George Alan**; 5775 Morehouse Drive, San Diego, California 92121-1714 (US). **LEE, Chulkyu**; 5775 Morehouse Drive, San Diego, California 92121-1714 (US). **CH-EUNG, Joseph**; 5775 Morehouse Drive, San Diego, California 92121-1714 (US).

(74) **Agent: LOZA, Julio**; Loza & Loza, LLP, 305 North Second Avenue #127, Upland, California 91786 (US).

(81) **Designated States** (unless otherwise indicated, for every kind of national protection available): AE, AG, AL, AM, AO, AT, AU, AZ, BA, BB, BG, BH, BN, BR, BW, BY, BZ, CA, CH, CL, CN, CO, CR, CU, CZ, DE, DK, DM, DO, DZ, EC, EE, EG, ES, FI, GB, GD, GE, GH, GM, GT, HN, HR, HU, ID, IL, IN, IR, IS, JP, KE, KG, KN, KP, KR, KZ, LA, LC, LK, LR, LS, LT, LU, LY, MA, MD, ME, MG, MK, MN, MW, MX, MY, MZ, NA, NG, NI, NO, NZ, OM, PA, PE, PG, PH, PL, PT, QA, RO, RS, RU, RW, SA, SC, SD, SE, SG, SK, SL, SM, ST, SV, SY, TH, TJ, TM, TN, TR, TT, TZ, UA, UG, US, UZ, VC, VN, ZA, ZM, ZW.

(84) **Designated States** (unless otherwise indicated, for every kind of regional protection available): ARIPO (BW, GH, GM, KE, LR, LS, MW, MZ, NA, RW, SD, SL, SZ, TZ, UG, ZM, ZW), Eurasian (AM, AZ, BY, KG, KZ, RU, TJ, TM), European (AL, AT, BE, BG, CH, CY, CZ, DE, DK, EE, ES, FI, FR, GB, GR, HR, HU, IE, IS, IT, LT, LU, LV, MC, MK, MT, NL, NO, PL, PT, RO, RS, SE, SI, SK, SM, TR), OAPI (BF, BJ, CF, CG, CI, CM, GA, GN, GQ, GW, KM, ML, MR, NE, SN, TD, TG).

**Published:**  
— with international search report (Art. 21(3))

(54) **Title:** TRANSCODING METHOD FOR MULTI-WIRE SIGNALING THAT EMBEDS CLOCK INFORMATION IN TRANSITION OF SIGNAL STATE

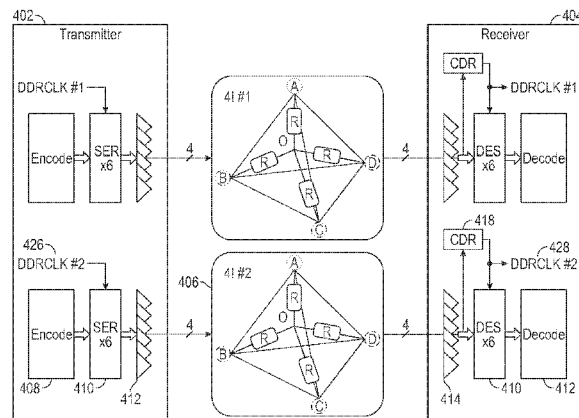

FIG. 4

(57) **Abstract:** A method for performing multi-wire signaling encoding is provided in which a clock signal is encoded within symbol transitions. A sequence of data bits is converted into a plurality of m transition numbers. Each transition number is converted into a sequential symbol number from a set of sequential symbol numbers. The sequential symbol number is converted into a raw symbol that can be transmitted over a plurality of differential drivers. The raw symbol is transmitted spread over a plurality of n wires, wherein the clock signal is effectively embedded in the transmission of raw symbols since the conversion from transition number into a sequential symbol number guarantees that no two consecutive raw symbols are the same. The raw symbol is guaranteed to have a non-zero differential voltage across all pairs of the plurality of n wires.

WO 2014/138644 A1

**TRANSCODING METHOD FOR MULTI-WIRE SIGNALING THAT EMBEDS  
CLOCK INFORMATION IN TRANSITION OF SIGNAL STATE**

**Claim of Priority under 35 U.S.C. §119**

[0001] The present Application for Patent claims priority to:

U.S. Provisional Application No. 61/774,408 entitled “Transcoding Method For Multi-Wire Signaling That Embeds Clock Information In Transition Of Signal State”, filed March 7, 2013,

U.S. Provisional Application No. 61/778,768 entitled “Transcoding Method For Multi-Wire Signaling That Embeds Clock Information In Transition Of Signal State”, filed March 13, 2013, and

U.S. Provisional Application No. 61/774,247 entitled “Circuit To Recover A Clock Signal From Multiple Wire Data Signals That Changes State Every State Cycle And Is Immune To Data Inter-Lane Skew As Well As Data State Transition Glitches”, filed March 7, 2013, all of which are assigned to the assignee hereof and hereby expressly incorporated by reference herein.

**Field**

[0002] The present disclosure pertains to transmitting and/or encoding a clock signal within cycles of a multi-signal data transfer.

**Background**

[0003] In multi-signal data transfer, for example, multi-wire differential signaling such as 3-phase or N-factorial low-voltage differential signaling (LVDS), transcoding (e.g., the digital-to-digital data conversion of one encoding to another) may be done to embed symbol clock information by causing a symbol transition at every symbol cycle, instead of sending clock information in separate data lanes (transmission paths). Embedding clock information by such transcoding is an effective way to minimize skew between clock and data signals, as well as to eliminate the necessity of a phase-locked loop (PLL) to recover the clock information from the data signals.

[0004] Some transcoding solutions (e.g., 3-wire differential signaling and/or 3-phase signaling) have implemented embedded clock information, but lack scalability.

[0005] Therefore, an efficient transcoding method is needed that supports any number of wires used in multi-wire signaling, such as N factorial differential signaling, and any number of symbols in a group that to be transcoded from any binary number.

### SUMMARY

[0006] A method for performing multi-wire signaling encoding is provided. A sequence of data bits are converted into a plurality of m transition numbers. Each transition number is converted into a sequential number from a set of sequential numbers. The sequential number is converted into a raw symbol. The raw symbol is transmitted via a plurality of differential drivers and spread over a plurality of n wires, wherein the clock signal is effectively embedded in the transmission of raw symbols since the conversion from transition number into a sequential number guarantees that no two consecutive raw symbols are the same. The raw symbol transmissions may be synchronized using the clock signal. Converting each transition number into a sequential number from a set of sequential numbers may include converting a plurality of transition numbers into a sequential number. Converting the sequential number into a raw symbol may include converting the sequential number into a plurality of raw symbols. In one example, the plurality of n wires may be greater than or equal to 3 or 4. The raw symbol is guaranteed to have a non-zero differential voltage across all pairs of the plurality of n wires. For an n factorial differential signal across the pairs of the n wires,  $r^m$  possible different states are represented by the transition numbers, where r is  $n!-1$  and m is the plurality of transition numbers. The sequential number may be selected from transition number based on a transition from an immediately previous sequential symbol number.

[0007] An encoding circuit for performing multi-wire signaling encoding is provided. A bits-to-transition number converter may convert a sequence of data bits into a plurality of m transition numbers. A transition number-to-sequential number converter may convert each transition number into a sequential number from a set of sequential numbers. A sequential number-to-raw symbol converter may convert the sequential number into a raw symbol. A plurality of differential drivers may transmit the raw symbol spread over a plurality of n wires, wherein a clock signal is effectively embedded in the transmission of raw symbols since the conversion from transition

number into a sequential number guarantees that no two consecutive raw symbols are the same.

[0008] For an  $n$  factorial differential signal across pairs of the  $n$  wires,  $r^m$  possible different states are represented by the transition numbers, where  $r$  is  $n!-1$  and  $m$  is the plurality of transition numbers.

[0009] In one example, the plurality of differential drivers is equal to  ${}_nC_2$ , where  ${}_nC_2 = n(n-1)/2$ . In another example, the plurality of differential drivers is equal to  $n$ .

[0010] The sequential number may be selected from the transition number based on a transition from an immediately previous sequential symbol number.

[0011] A method for performing multi-wire signaling decoding is also provided. A raw symbol is received spread over a plurality of  $n$  wires via a plurality of differential receivers. The raw symbol may be converted into a sequential number from a set of sequential numbers. Each sequential number may be converted to a transition number. A plurality of transition numbers may be converted into a sequence of data bits. A clock signal may be extracted from the reception of raw symbols. Raw symbol reception may be synchronized using the clock signal.

[0012] Converting each sequential number to a transition number may include converting a sequential number into a plurality of transition numbers. Converting the raw symbol into a sequential number from a set of sequential numbers may include converting a plurality of raw symbols into a sequential number. In various examples, the plurality of  $n$  wires is greater than or equal to 3 or 4. The raw symbol is guaranteed to have a non-zero differential voltage across all pairs of the  $n$  wires. For an  $n$  factorial differential signaling across the  $n$  drivers,  $r^m$  possible different states are represented by the transition numbers, where  $r$  is  $n!-1$ . The transition number may be selected from the sequential number and based on an immediately previous sequential symbol number.

[0013] A decoding circuit for performing multi-wire signaling decoding is also provided. A plurality of differential receivers may receive a raw symbol spread over a plurality of  $n$  wires. A raw symbol-to-sequential number converter may convert the raw symbol into a sequential number from a set of sequential numbers. A sequential number-to-transition number converter may convert each sequential number to a transition number. A transition number-to-bits converter may convert a plurality of transition numbers into a sequence of data bits. A clock data recovery circuit may extract a clock signal from the reception of raw symbols. Raw symbol reception may be synchronized using the clock signal.

[0014] In one example, the plurality of differential drivers is equal to  ${}_nC_2$ , where  ${}_nC_2 = n(n-1)/2$ . In another example, the plurality of differential drivers is equal to  $n$ . The transition number may be selected from the sequential number and based on an immediately previous sequential symbol number.

## DRAWINGS

[0015] Various features, nature and advantages may become apparent from the detailed description set forth below when taken in conjunction with the drawings in which like reference characters identify correspondingly throughout.

[0016] FIG. 1 illustrates a four factorial modulation data encoding/decoding scheme used between a transmitter device and a receiver device.

[0017] FIG. 2 illustrates another four factorial modulation data encoding/decoding scheme used between a transmitter device and a receiver device.

[0018] FIG. 3 illustrates another four factorial modulation data encoding/decoding scheme used between a transmitter device and a receiver device.

[0019] FIG. 4 illustrates another four factorial modulation data encoding/decoding scheme used between a transmitter device and a receiver device via a multi-wire transmission path.

[0020] FIG. 5 is a block diagram of a transmitter (encoder) device in which a clock is integrated into symbol transitions.

[0021] FIG. 6 is a block diagram of a receiver (decoder) device with integrated clock recovery.

[0022] FIG. 7 illustrates the conversion from bits to symbol transition numbers at a transmitter and then from symbol transition numbers to bits at a receiver.

[0023] FIG. 8 illustrates the conversion between sequential symbol numbers and symbol transition numbers.

[0024] FIG. 9 is a table illustrating the conversion between raw symbols (for a  $n=3$  wire system) to a sequential symbol number.

[0025] FIG. 10 illustrates a 3-wire termination network showing the input drivers and output receivers as well as the current flow among the various nodes.

[0026] FIG. 11 (comprising FIGS. 11A and 11B) illustrates a 4-wire termination network showing the input drivers and output receivers as well as the current flow among the various nodes.

[0027] FIG. 12 illustrates a transmitter to receiver transcoding scheme showing the transmitter drivers, receiver drivers, and 4-wire termination network.

[0028] FIG. 13 (comprising FIGS. 13A and 13B) is a table showing the various combinations of raw symbols and those symbols having zero differential voltage for  $n=4$ .

[0029] FIG. 14 illustrates a table with the non-zero differential voltage raw symbols (Sraw) that have been obtained from FIGS. 13A and 13B.

[0030] FIG. 15 is a block diagram illustrating the conversion of bits to symbol transition numbers for an  $n$ -wire system.

[0031] FIG. 16 is a block diagram of an exemplary encoder illustrating an example of a conversion of bits to symbol transition number for a 3-wire system (for  $n=3$  with 7 symbols per group).

[0032] FIG. 17 is a block diagram of an exemplary decoder illustrating an example of a conversion of symbol transition numbers to bits for a 3-wire system (for  $n=3$  with 7 symbols per group).

[0033] FIG. 18 is a block diagram illustrating exemplary transmitter and receiver devices for a generalized for an  $n$ -factorial (or  $n!$ ) transcoding scheme.

[0034] FIG. 19 is a block diagram illustrating an example of the bussed transcoding (RX side only) for  $4! m=2$  case when  $w=8$ .

[0035] FIG. 20 illustrates a utilization table for a 3-wire system at various symbols per group.

[0036] FIG. 21 illustrates a utilization table for a 4-wire system at various symbols per group.

[0037] FIG. 22 illustrates a utilization table for a 5-wire system at various symbols per group.

[0038] FIG. 23 illustrates a utilization table for a 6-wire system at various symbols per group.

[0039] FIG. 24 illustrates a utilization table for a 7-wire system at various symbols per group.

[0040] FIG. 25 illustrates a method for performing multi-wire signaling encoding in which a clock signal is encoded within symbol transitions.

[0041] FIG. 26 illustrates a method for performing multi-wire signaling decoding in which a clock signal is extracted from symbol transitions.

[0042] FIG. 27 illustrates a 3-wire differential signaling scheme with an integrated clock based on state transitions (raw symbol transitions).

[0043] FIG. 28 illustrates a table 2802 for N-factorial differential signaling.

### DETAILED DESCRIPTION

[0044] In the following description, specific details are given to provide a thorough understanding of the embodiments. However, it will be understood by one of ordinary skill in the art that the embodiments may be practiced without these specific detail. For example, circuits may be shown in block diagrams in order not to obscure the embodiments in unnecessary detail. In other instances, well-known circuits, structures and techniques may not be shown in detail in order not to obscure the embodiments.

#### Overview

[0045] Various transcoding methods for conveying transcoding systems using differential signaling over a plurality of wires.

[0046] A first aspect provides multi-wire signaling encoding in which a clock signal is encoded within symbol transitions. A sequence of data bits is converted into a plurality of  $m$  transition numbers. Each transition number is converted into a sequential symbol number from a set of sequential symbol numbers. The sequential symbol number is converted into a raw symbol. The raw symbol is transmitted via a plurality differential drivers and spread over a plurality of  $n$  wires, wherein the clock signal is effectively embedded in the transmission of raw symbols since the conversion from a transition number into a sequential symbol number guarantees that no two consecutive raw symbols are the same.

[0047] A second aspect provides multi-wire signaling decoding in which a clock signal is extracted from symbol transitions. A raw symbol is received spread over a plurality of  $n$  wires via a plurality of differential receivers. The raw symbol is converted into a sequential symbol number from a set of sequential symbol numbers. Each sequential symbol number is converted to a transition number. A plurality of transition numbers are converted into a sequence of data bits. A clock signal is extracted from the transition of raw symbols.

#### Exemplary Transcoding Systems with Dedicated Clock Channel and/or Phase Lock Loop Hardware

[0048] FIG. 1 illustrates a four factorial modulation data encoding/decoding scheme used between a transmitter device 102 and a receiver device 104. The factorial data encoding/decoding scheme may include an encoder 110, transmitter circuit 112, physical wires 107 (e.g., four conductors, lines, or electrical paths), a tetrahedron termination network 106, and receiver circuit 114, and a decoder 116. The transmitter circuit 112 may include a serializer 118, which serializes data streams, and a plurality of drivers 120. The receiver circuit 114 may include a plurality of receivers 122 and a deserializer 124, which deserializes data streams. It should be clear that the tetrahedron termination network 106 is actually present at the interface of each of the transmitter 102 and receiver 104, and that a plurality of wires (i.e., wires A, B, C, and D in this example) are coupled between the termination networks of the transmitter 102 and receiver 104. In this example, six drivers 120 may be used to generate four differential signals transmitted over four conductors. However, other numbers of drivers and differential signals may be used in other implementations.

[0049] A separate lane may be used as a clock channel 108. The disadvantage with this approach is that it leads to data skew and requires two extra lines to implement.

[0050] FIG. 2 illustrates another four factorial modulation data encoding/decoding scheme 206 used between a transmitter device 202 and a receiver device 204. The factorial data encoding/decoding scheme may include an encoder 210, transmitter circuit 212, physical wires (e.g., four conductors or lines), a tetrahedron termination network 206, and receiver circuit 214, and a decoder 216. In this example, one driver-receiver pair 208a/208b in the encoder/decoder system is now used to transmit/receive the clock signal. However, rather than using six drivers for data transmissions only five drivers 220 are used for data transmissions while one driver 208a is used for the clock signal. As a result of dedicating a driver-receiver pair 208a and 208b for the clock signal, the number of states transmitted per symbol (for data transmissions) is reduced by half. For example, in the case of 4-factorial signaling, twenty-four (24) states per symbol may normally be transferred if all bits are used for data. In the case where one driver-receiver pair is used for the clock signal, only twelve (12) states per symbols are transmitted.

[0051] FIG. 3 illustrates another four factorial modulation data encoding/decoding scheme 306 used between a transmitter device 302 and a receiver device 304. In this example, the serializer 318 may be synchronized by the clock signal 326. Phase-lock loops 308 may be used at the receiver 304 to extract the clock signal 328. For example,

a non-return-to-zero decoding may be implemented to extract the clock signal from the data signals. But this approach requires the phase-lock loops 308 which consume power and take up space on a semiconductor device.

### **Exemplary Multi-Wire System With Integrated Clock Based On Symbol Transitions**

[0052] FIG. 4 illustrates another four factorial modulation data encoding/decoding scheme used between a transmitter device 402 and a receiver device 404 via a multi-wire transmission path. At the transmitter device 402, an encoder 408, a serializer (SER) module 410, a plurality of differential drivers 412, and a termination network 406, may be adapted to implement the four factorial modulation data encoding scheme. At the receiver 404, a termination network 406, receivers or sinks 414, a deserializer (DES) module 410, and a decoder 412 may be adapted to implement the four factorial modulation data decoding scheme. It should be clear that the termination network 406 is actually present at the interface of each of the transmitter device 402 and receiver device 404, and that a plurality of wires (i.e., wires A, B, C, and D in this example) are coupled between the termination networks of the transmitter device 402 and receiver device 404.

[0053] In contrast to the approaches illustrated in FIGS. 1 and 2, or 3, the approach in FIG. 4 does not use a separate clock channel, a separate transmitter/receiver, nor non-return-to-zero decoding that requires PLL to extract clock information. Instead, a clock signal 426 may be embedded within symbol transitions carrying data. A clock data recovery circuit 418 decodes the symbol transitions to extract the clock 428.

[0054] In this approach, a plurality of wires (e.g., conductors, lines, etc.) carry differentially encoded signals carrying multiple symbols. If  $n$  wires (e.g., conductors or lines) are used to transmit a differential signal, a maximum of  $n!-1$  symbols may be represented using the  $n$  wires. It is contemplated that the term “wire” and/or “wires” be broadly construed and include all forms of physical conductors, paths, lines, etc., that may serve to carry a signal between two points.

[0055] Within this transcoding system, the clock signal is extracted from symbol transitions. Three conversions are contemplated in this transcoding scheme: (a) between raw symbols and sequential symbol numbers, (b) between sequential symbol numbers and symbol transition numbers, and (c) between symbol transition numbers and bits. The transcoding scheme is designed so that it guarantees that consecutive raw symbols are guaranteed to be different (i.e., transition every cycle). Consequently, the raw

symbol transitions can be used by the receiver 404 to generate, construct, or extract a clock signal.

[0056] FIG. 5 is a block diagram of a transmitter (encoder) device 402 in which a clock is integrated into symbol transitions. The transmitter device 402 may include a bits-to-transitions symbols converter 502, a transition-symbol-to-sequential symbol converter 504, a sequential-symbol-to-raw-symbol converter 506, and a plurality of drivers 508 that transmit the raw symbols over a plurality of  $n$  wires.

[0057] FIG. 6 is a block diagram of a receiver (decoder) device 404 with integrated clock recovery. The receiver device 404 may include a plurality of receivers 608 that receive the raw symbols over a plurality of  $n$  wires, a raw-symbol-to-sequential symbol converter 606, a sequential-symbol-to-transition-symbol converter 604, and a symbol transitions-to-bits converter 602.

### **Exemplary Conversion Between Bits and Symbol Transition Numbers**

[0058] FIG. 7 illustrates the conversion from bits to symbol transition numbers at a transmitter 702 and then from symbol transition numbers to bits at a receiver 704. The transmitter 702 feeds binary information, Bits, into a “Bits to  $m \times T$ ” converter 706 to generate  $m$  symbol transition numbers,  $T_0$  to  $T_{m-1}$ . The receiver 704 receives  $m$  symbol transition numbers,  $T_0$  to  $T_{m-1}$ , which are fed into a “ $m \times T$  to Bits” converter 708 to retrieve the binary information, Bits. If there are  $r$  possible symbol transition states per one  $T$ ,  $T_0$  to  $T_{m-1}$ ,  $m$  transitions can send  $r^m$  different states. For  $N!$  differential signaling,  $r = n! - 1$ . Consequently, transitions  $T_0 \dots T_{m-1}$  contain data that can have  $(n! - 1)^m$  different states.

[0059] In one example, it may be assumed the possible symbol transition per one  $T$ ,  $r$  is 10. Lets also assume the number of symbols in a group,  $m$  is 3, such that the symbol transition number is  $T_2, T_1, T_0$ , where  $T_i: 0, 1, 2, \dots, 9$ . Thus, each  $T$  can have 10 different states. Thus, the symbol transition number for  $T_2, T_1, T_0$  may be for example, a 3-digit number, such as  $T_2=3, T_1=9, T_0=1$  (or the decimal number 391). In this manner a sequence of bits may be converted into a plurality of symbol transition numbers  $T$  and vice versa.

[0060] In another example,  $3!$  ( $n=3$ ), it may be assumed the possible symbol transition per one  $T$ ,  $r$  is 5 ( $= 3! - 1$ ). If the number of symbols in a group,  $m$  is 4, a four-digits quinary number (base-5 number):  $T_3, T_2, T_1, T_0$ , where each  $T_i: 0, 1, 2, 3, 4$ . For

example, for  $T_3=1$ ,  $T_2=2$ ,  $T_1=0$ ,  $T_0=3$ , the quinary number is  $1203_5 = 1 \times 5^3 + 2 \times 5^2 + 0 \times 5^1 + 3 \times 5^0 = 178$ . In this manner, four transitions numbers may be converted into a number. Note that the transition number  $1203_5$  may be used as the transition number, for example, in FIG. 8, so that each integer may be mapped to a sequential symbol and vice versa.

**[0061]** FIG. 15 is a block diagram illustrating the conversion of bits to symbol transition numbers for an n-wire system. This conversion from bits to symbol transition numbers T may be performed by a bits-to-symbol transition number converter 1506 within an encoder 1504 which may be part of a transmitter 1502. The transmitter 1502 and encoder 1504 may operate similar to that illustrated in FIG. 5.

**[0062]** FIG. 16 is a block diagram of an exemplary encoder illustrating an example of a conversion of bits to symbol transition number for a 3-wire system (for  $n=3$  with 7 symbols per group). A transmitter device 1602 may include an encoder 1604 that implements a bits-to-symbol transition number converter 1606, a symbol transition number-to-sequential symbol number converter 1608, and a sequential symbol number-to-raw-symbol converter 1610, and three drivers 1612 that transmit the raw symbols over a plurality of 3 wires. The transmitter 1602 and encoder 1604 may operate similar to that illustrated in FIG. 5.

**[0063]** FIG. 17 is a block diagram of an exemplary decoder illustrating an example of a conversion of symbol transition numbers to bits for a 3-wire system (for  $n=3$  with 7 symbols per group). A receiver device 1702 may include a plurality of receivers 1703 that receive the raw symbols over a plurality of n wires, a raw symbol-to-sequential symbol number converter 1706, a sequential symbol number-to-symbol transition number converter 1708, and a symbol transition number-to-raw bits converter 1710. The receiver 1702 and decoder 1704 may operate similar to that illustrated in FIG. 6.

### **Exemplary Conversion Between Sequential Symbols and Symbol Transition Number**

**[0064]** FIG. 8 illustrates the conversion between sequential symbols and symbol transition numbers. This conversion maps each transition from a previous sequential symbol number ( $P_s$ ) to a current sequential symbol number ( $C_s$ ) to a transition number (T). At the transmitter device, the symbol transition numbers are being converted to sequential symbol numbers. Because of the relative conversion scheme being used, the

transition numbers guarantee that no two consecutive sequential symbol numbers 804 will be the same.

[0065] In one example for a 3-wire system, there are six raw symbols assigned to six sequential symbol numbers S0, S1, S2, S3, S4, and S5. For the six sequential symbol numbers 804, Table 802 illustrates how a transition number (T) may be assigned based on a previous sequential symbol number (Ps) and the current sequential symbol number (Cs).

[0066] In this example, the transition number T may be assigned according to:

$$T = Ps+1 \leq Cs$$

$$? Cs - (Ps+1)$$

$$: Cs - (Ps+1) + 6$$

[0067] Conversely, the current sequential symbol number (Cs) may be assigned according to:

$$Cs = Ps+1 + T < 6$$

$$? Ps+1 + T$$

$$: Ps+1 + T - 6$$

[0068] A similar approach may be used for an n-wire system by constructing a mapping of sequential symbol number to transition number table for any n (e.g., n=4, 5, 6, ...) that guarantees that the raw symbols will change.

[0069] For example, in the case of an n-wire system, the transition number T may be assigned according to:

$$T = Ps+1 \leq Cs$$

$$? Cs - (Ps+1)$$

$$: Cs - (Ps+1) + n!$$

[0070] Conversely, in the case of an n-wire system, the current sequential symbol number (Cs) may be assigned according to:

$$Cs = Ps+1 + T < n!$$

$$? Ps+1 + T$$

$$: Ps+1 + T - n!$$

**Exemplary Conversion Between Sequential Symbol Numbers and Raw Symbols**

[0071] FIG. 9 is a table illustrating the conversion between raw values (for a n=3 wire system) to a sequential symbol number. In this example for n=3, the combinations of raw data values X, Y, and Z may be mapped to one of a set of sequential symbol

number 0-5. The combination of raw values X, Y, and Z (e.g., {Z, Y, Z}) represents a raw symbol. The mnemonics  $-x$ ,  $+x$ ,  $+y$ ,  $-y$ ,  $+z$ , and  $-z$  are used to represent each of the six raw symbols for the 3-phase system (where  $n=3$ ). Because the raw symbol is guaranteed to change every cycle (i.e., no two consecutive raw symbols are the same), the transition from one raw symbol to the next raw symbol can be used to extract a clock signal.

### **Exemplary 3-Wire Transcoding System with Embedded Timing Information**

[0072] FIG. 27 illustrates a 3-wire differential signaling scheme between a transmitter device 2700 and a receiver device 2701 in which a clock (timing information) is embedded based the states defined by differential signals among conductors, wires, or lines A, B, and C.

[0073] The transmitter device 2700 and receiver device 2701 may communicate over a multi-line bus 2708. In this example, three lines A, B, and C are used for the bus 2708. The receiver device 2701 may include a three-port receiver 2710 to couple the receiver device 2701 to the bus 2708.

[0074] In one example, differential signal encoding/decoding, as illustrated in FIGS. 4-9, may be used to transmit signals from the transmitter device 2700 the receiver device 2701. As part of the receiver termination network, each of a plurality of receivers 2712 may be configured to take two of the three lines A, B, and C and provide a different signal. For instance, a first line A and a second line B may serve to provide a first differential signal RX\_AB 2714, the second line B and a third line C may serve to provide a second differential signal RX\_BC 2716, and the first line A and the third line C may serve to provide a third differential signal RX\_CA 2718 RX. These differential signals 2714, 2716, and 2718 may serve as inputs to a decoder circuit 2720. The decoder circuit 2720 decodes the three differential signals RX\_AB 2714, RX\_BC 2716, and RX\_CA 2718 and outputs the six states XM, YM, ZM, ZP, YP, and XP (also represented as  $-x$ ,  $-y$ ,  $-z$ ,  $+z$ ,  $+y$ , and  $+x$  in FIG. 9).

[0075] A state diagram 2703 illustrates the six (6) states XM, YM, ZM, ZP, YP, and XP that may be defined by the differential signals 2714, 2716, and 2718 carried by the three conductors A, B, and C 2708. As can be observed, the voltage levels across the three differential signals 2714, 2716, and 2718 may be mapped to different combinations of ones (1) and zeros (0). For instance, the differential signal voltage levels for state XM may be associated with "011", state YM may be associated with

“101”, state ZP may be associated with “001”, state ZM may be associated with “110”, state YP may be associated with “010”, and state XP may be associated with “100”.

**[0076]** In addition to the information encoded in the states (e.g., 3 bits per state), information may also be encoded based on transitions between the states. Note that transition between any two states (XM, YM, ZM, ZP, YP, and XP) occurs in a single step without traversing intermediate states. As such, differential data transmission schemes based on the state diagram 2703 would be free of state transition decoding problems. Because of this encoding, no two consecutive raw symbols are the same. The guaranteed transition of raw symbols (i.e., change of states XM, YM, ZM, ZP, YP, and XP every cycle) permits using such transition to generate or extract a clock at the receiver device 2701.

**[0077]** Each of the conductors, wires, or lines of the bus 2708 may be driven High, driven Low, or undriven, with only one conductor being undriven in any single cycle. In one embodiment, three differential signals, RX\_AB 2714, RX\_BC 2716, and RX\_CA 2718 (e.g., received by a decoder 2720 within receiver device 2701), are defined as positive differential voltage to logic 1 and negative differential voltage to logic 0 between conductor A relative to conductor B, conductor B relative to conductor C, and conductor C relative to conductor A respectively. Example waveforms of the three differential signals 2714, 2716, and 2718 are illustrated in the diagram 2704.

**[0078]** Six possible states (excluding the states that cause a zero differential voltage between conductor A relative to conductor B, conductor B relative to conductor C, and conductor C relative to conductor A) are defined as XM, YM, ZP, ZM, YP, XP, and XM by states of the signals RX\_AB 2714, RX\_BC 2716, and RX\_CA 2718 according to state diagram 2703.

**[0079]** State signals corresponding to the six possible states XM, YM, ZP, ZM, YP, XP, and XM are generated from the differential signals RX\_AB 2714, RX\_BC 2716, and RX\_CA 2718 by a decoder block 2720 (DEC), in the receiver device 2701, and exemplary waveforms of the state signals are shown in the diagram 2705.

**[0080]** In one embodiment, a state transition from a state, XM, YM, ZP, ZM, YP, XP, or XM, to a different state always occurs every single cycle. Consequently, the state transition may be used to represent a clock signal that is transmitted from the transmitter device 2700 to the receiver device 2701. The receiver device 2701 may then extract the clock signal from the guaranteed state transitions (i.e., guaranteed transitions between consecutive raw symbols).

### Exemplary Termination Networks

**[0081]** FIG. 10 illustrates a 3-wire termination network 1002 showing the input to drivers and output from receivers as well as the current flow among the various nodes. This transcoding scheme for  $n=3$  has two patterns  $(ZYX) = (000)$  and  $(111)$  which cause a zero differential voltage and are thus illegal states. Zero differential voltages are illegal because they cannot be distinguished from each other, thus preventing accurate decoding. The illegal states must not be used for encoding. The remaining six (legal) states are  $(ZYX) = (001), (010), (100), (110), (101),$  and  $(011)$ .

**[0082]** FIG. 11 (comprising FIGS. 11A and 11B) illustrates a 4-wire termination network 1102 showing the input to drivers and output from receivers as well as the current flow 1104 among the various nodes. The 4-wire termination network 1102 includes four termination resistors, six differential drivers and six differential receivers (drivers/sinks), and use three differential voltage levels. The table 1106 illustrates the possible unit current flows across each termination resistance  $R$ . As can be observed from the termination network 1102, each termination resistance  $R$  is couple to three (3) drivers/sinks 1107. Assuming a unit current of  $+1$  or  $-1$  from each driver/sink, then table 1106 illustrates the possible net current flows for each termination resistance  $R$ :  $+3, +1, -1, -3$ .

**[0083]** FIG. 12 illustrates a transmitter to receiver transcoding scheme showing the transmitter drivers, receiver drivers, and 4-wire termination network.

**[0084]** The 4-wire termination network 1102 of FIGS. 11 and 12 has 64 possible states (i.e., six drivers and  $2^6$  states). However, as further described with reference to FIG. 13 below, of the 64 possible states, 40 are illegal states because they result in zero differential voltages (as illustrated in FIG. 13). For each termination resistance  $R$ , there are four possible currents (magnitude and direction):  $-3, -1, +1,$  and  $+3$  for one driver. The differential voltage of  $XY$  becomes zero (0) when two resistors ( $XO$  and  $YO$ ) have currents of the same size and same direction. Thus, only the remaining 24 “non-zero” states may be used a raw symbols.

**[0085]** FIG. 13 (comprising FIGS. 13A and 13B) is a table showing the various combinations of raw symbols and those symbols having zero differential voltage for  $n=4$ . This table may be interpreted with respect to the 4-wire termination network of FIGS. 11 and 12.  $S_{raw}$  refers to the raw symbols formed by the differential signals at  $CD, DB, AD, AC, CB,$  and  $AB$ , in FIG. 12. The voltage at each  $R_{term}$  refers to the

voltage across each resistor  $R$  between a central node  $O$  and each node  $A$  in the termination network 1102 in FIG. 11. In this example, assuming a unitary resistance  $R$ , the voltage across each resistance  $R_{term}$  is given as +3, +1, -1, or -3 as in the possible currents in table 1106 in FIG. 11. As a result of these voltages across each  $R_{term}$ , a differential voltage across each driver/sink (DB, CD, AD, AC, CD, and AB), can be ascertained in the termination network 1102 in FIG. 11. In some cases, the voltages across two resistor pairs  $R_{term}$  for a given differential transmitter/receiver cancel each other out, resulting in a “0” differential voltage. As a result, such conditions are undistinguishable raw symbols  $S_{raw}$  where such conditions occur are undecodable/indistinguishable and considered “illegal” and not used.

[0086] FIG. 14 illustrates a table with the non-zero differential voltage raw symbols ( $S_{raw}$ ) that have been obtained from FIGS. 13A and 13B. Because only a subset of the possible combinations may serve as a valid raw symbol, a mapping may be used to guarantee that an illegal state is never used as a raw symbol.

[0087] For any given number of  $n$  wires (e.g., conductors, lines, etc.), a similar table is generated and used to define the raw symbols (from the valid “non-zero” states). A mapping of raw symbols to sequential symbols may be done as illustrated in FIG. 9. Note that this mapping guarantees that only valid symbols (“non-zero differential voltage states”) are transmitted. Because of the symbol transition number to sequential symbol conversion that occurs at a transmitter prior to transmission of the raw symbols, no two consecutive raw symbols will be the same, they always change. Even if the exact same group of bits are being transmitted twice or more in a row (e.g., all 1s or all 0s bits), the raw bits will be different. This change in raw symbols guarantees a “transition” every time a raw symbol is transmitted. Consequently, a clock can be extracted from such guaranteed transition of the raw symbols.

### **Exemplary $N!$ Transcoding System**

[0088] FIG. 18 is a block diagram illustrating exemplary transmitter and receiver devices for a generalized for a  $n$  factorial ( $n!$ ) transcoding scheme, where  $n$  is the number of wires (e.g., conductors, lines) used,  $m$  are the symbols/group, and  $w$  is the bit width of the deserializer (DES) 1806 and serializer (SER) 1826 blocks. In this example, a receiver device 1802 may include a decoder 1804 which includes DES block 1806. The decoder 1804 may operate similar to that illustrated and described in FIG. 6. Additionally, a transmitter device 1822 may include an encoder 1824 which includes

SER block 1826. The encoder 1824 may operate similar to that illustrated and described in FIG. 5.

[0089] In one example, if  $n = 4$ ,  $m = 2$ , and  $w = 8$  with which 2-symbols can transfer 9-bits, 8 symbols are processed at the same time by the transcoding in both TX and RX sides.

[0090] FIG. 19 is a block diagram illustrating an example of the bussed transcoding (RX side only) for  $n=4$ ,  $m=2$ , and  $w = 8$ . This example, illustrates a detailed view of the receiver 1802 and decoder 1804 of FIG. 18. As illustrated, each of the six receivers 1912 may use six deserializers 1914, with separate decoder circuits being used for the decoding of different bits in a sequence of bits.

#### **Exemplary Data Encoding Device and Method with Integrated Clock**

[0091] An encoding circuit for performing multi-wire signaling encoding is provided. Various examples of such encoding circuit and functions performed therein are found in FIG. 4 (transmitter 402), FIG. 5, FIG. 7, FIG. 8, FIG. 9, FIG. 13, FIG. 14, FIG. 15 (encoder 1504), FIG. 16 (encoder 1604), and FIG. 18 (encoder 1824). A bits-to-transition number converter serves to convert a sequence of data bits into a plurality of  $m$  transition numbers. A transition number-to-sequential number converter server to convert each transition number into a sequential number from a set of sequential numbers. Converting each transition number into a sequential number from a set of sequential numbers may include converting a plurality of transition numbers into a sequential number. A sequential number-to-raw symbol converter serves to convert the sequential number into a raw symbol.

[0092] Converting the sequential number into a raw symbol may include converting the sequential number into a plurality of raw symbols. The raw symbol may be guaranteed to have a non-zero differential voltage across all pairs of the  $n$  wires. For example, as illustrated in FIG. 27, the differential voltage 2703 across wires AB, BC, and CA is non-zero.

[0093] A plurality of differential drivers may serve to transmit the raw symbol spread over a plurality of  $n$  wires, wherein a clock signal is effectively embedded in the transmission of raw symbols since the conversion from transition number into a sequential number guarantees that no two consecutive raw symbols are the same. In various examples, the plurality of  $n$  wires is greater than or equal to 3 or 4.

[0094] For an  $n$  factorial differential signal across pairs of the  $n$  wires,  $r^m$  possible different states are represented by the transition numbers, where  $r$  is  $n!-1$ . The sequential number may be selected from the transition number based on a transition from an immediately previous sequential symbol number. For example, such selection of sequential symbol numbers is illustrated in FIG. 8.

[0095] In one example for an  $n$  factorial differential signal, the plurality of differential drivers is equal to  ${}_nC_2$ , where  ${}_nC_2 = n! / (2!(n-2)!) = n(n-1)/2$ . FIG. 28 illustrates a table 2802 for  $N$ -factorial differential signaling. For example, if  $n=6$  wires, 9.49 bits per cycle can be transmitted using 720 states per cycle, 5 differential voltage levels, and 15 drivers/receivers. Consequently, significantly more information may be transmitted over the same number of wires per cycle relative to the traditional differential signaling approach.

[0096] In another example, the plurality of differential drivers is equal to  $n$ . For instance, the termination network used may be designed such that the same number of differential drivers as wires is used for all values of  $n = 3, 4, 5, 6$ , etc.

[0097] FIG. 25 illustrates a method for performing multi-wire signaling encoding in which a clock signal is encoded within symbol transitions. A sequence of data bits is converted into a plurality of  $m$  transition numbers 2502. Each transition number is converted into a sequential symbol number from a set of sequential symbol numbers 2504. The sequential symbol number is converted into a raw symbol 2506. The raw symbol is transmitted spread over a plurality of differential drivers and spread over a plurality of  $n$  wires (e.g., conductors or lines), wherein the clock signal is effectively embedded in the transmission of raw symbols since the conversion from transition number into a sequential number guarantees that no two consecutive raw symbols are the same 2508.

#### **Exemplary Decoding Device and Method with Clock Recovery**

[0098] A decoding circuit for performing multi-wire signaling decoding is provided. Various examples of such decoding circuit and functions performed therein are found in FIG. 4 (receiver 402), FIG. 6, FIG. 7, FIG. 8, FIG. 9, FIG. 13, FIG. 14, FIG. 17 (decoder 1704), and FIG. 18 (decoder 1804). A plurality of differential receivers may serve to receive a raw symbol spread over a plurality of  $n$  wires. In various examples, the plurality of  $n$  wires is greater than or equal to 3 or 4.

[0099] A raw symbol-to-sequential number converter may serve to convert the raw symbol into a sequential number from a set of sequential numbers. Converting the raw symbol into a sequential number from a set of sequential numbers may include converting a plurality of raw symbols into a sequential number. The raw symbol is guaranteed to have a non-zero differential voltage across all pairs of the plurality of  $n$  wires.

[00100] A sequential number-to-transition number converter may serve to convert each sequential number to a transition number. Converting each sequential number to a transition number may include converting a sequential number into a plurality of transition numbers. The transition number may be selected from the sequential number and based on an immediately previous sequential symbol number.

[00101] A transition number-to-bits converter may serve to convert a plurality of transition numbers into a sequence of data bits. A clock data recovery circuit may extract a clock signal from the reception of raw symbols. The raw symbol reception is synchronized using the clock signal.

[00102] For an  $n$  factorial differential signaling across the  $n$  drivers,  $r^m$  possible different states may be represented by the transition numbers, where  $r$  is  $n!-1$ .

[00103] FIG. 26 illustrates a method for performing multi-wire signaling decoding in which a clock signal is extracted from symbol transitions. A raw symbol is received spread over a plurality of  $n$  wires via a plurality of differential receivers 2602. The raw symbol is converted into a sequential number from a set of sequential numbers 2604. Each sequential symbol number is converted to a transition number 2606. A plurality of transition numbers are converted into a sequence of data bits 2608. A clock signal is extracted from the reception of raw symbols 2610.

### **Exemplary Utilizations**

[00104] Depending on the number of wires used and the symbols/group selected, different utilization percentages may be achieved. "Utilization" may refer to the efficiency with which a number of bits per group may be sent. In these example, "utilization" may be represented as a percentage between an integer number of bits per group that are transmitted and a theoretical number of bits per group that may be transmitted for a given number of conductors and symbols per group.

[00105] FIG. 20 illustrates a utilization table for a 3-wire system at various symbols per group. In this example, 2.321 bits/cycle can be sent by 28 symbols/group, while a 1 symbol/group can only send 2 bits/cycle.

[00106] FIG. 21 illustrates a utilization table for a 4-wire system at various symbols per group. In this example, 4.5 bits/cycle can be sent by 2 symbols/group, while a 1 symbol/group can only send 4 bits/cycle.

[00107] FIG. 22 illustrates a utilization table for a 5-wire system at various symbols per group. In this example, 6.8947 bits/cycle can be sent by 19 symbols/group, while 1 symbol/group can only send 6 bits/cycle. Notably, 14 symbols/group can send 96 bits (32x3).

[00108] FIG. 23 illustrates a utilization table for a 6-wire system at various symbols per group. In this example, 9.483 bits/cycle can be sent by 31 symbols/group, while 1 symbol/group can only send 9 bits/cycle.

[00109] FIG. 24 illustrates a utilization table for a 7-wire system at various symbols per group. In this example, 12.296 bits/cycle can be sent by 27 symbols/group, while 1 symbol/group can only send 12 bits/cycle.

[00110] One or more of the components, steps, features and/or functions illustrated in the Figures may be rearranged and/or combined into a single component, step, feature or function or embodied in several components, steps, or functions. Additional elements, components, steps, and/or functions may also be added without departing from novel features disclosed herein. The apparatus, devices, and/or components illustrated in the Figures may be configured to perform one or more of the methods, features, or steps described in the Figures. The novel algorithms described herein may also be efficiently implemented in software and/or embedded in hardware.

[00111] One or more of the components, steps, features and/or functions illustrated in the Figures may be rearranged and/or combined into a single component, step, feature or function or embodied in several components, steps, or functions. Additional elements, components, steps, and/or functions may also be added without departing from novel features disclosed herein. The apparatus, devices, and/or components illustrated in the Figures may be configured to perform one or more of the methods, features, or steps described in the Figures. The novel algorithms described herein may also be efficiently implemented in software and/or embedded in hardware.

[00112] Also, it is noted that the embodiments may be described as a process that is depicted as a flowchart, a flow diagram, a structure diagram, or a block diagram. Although a flowchart may describe the operations as a sequential process, many of the operations can be performed in parallel or concurrently. In addition, the order of the operations may be re-arranged. A process is terminated when its operations are completed. A process may correspond to a method, a function, a procedure, a subroutine, a subprogram, etc. When a process corresponds to a function, its termination corresponds to a return of the function to the calling function or the main function.

[00113] Moreover, a storage medium may represent one or more devices for storing data, including read-only memory (ROM), random access memory (RAM), magnetic disk storage mediums, optical storage mediums, flash memory devices and/or other machine readable mediums for storing information. The term “machine readable medium” includes, but is not limited to portable or fixed storage devices, optical storage devices, wireless channels and various other mediums capable of storing, containing or carrying instruction(s) and/or data.

[00114] Furthermore, embodiments may be implemented by hardware, software, firmware, middleware, microcode, or any combination thereof. When implemented in software, firmware, middleware or microcode, the program code or code segments to perform the necessary tasks may be stored in a machine-readable medium such as a storage medium or other storage(s). A processor may perform the necessary tasks. A code segment may represent a procedure, a function, a subprogram, a program, a routine, a subroutine, a module, a software package, a class, or any combination of instructions, data structures, or program statements. A code segment may be coupled to another code segment or a hardware circuit by passing and/or receiving information, data, arguments, parameters, or memory contents. Information, arguments, parameters, data, etc. may be passed, forwarded, or transmitted via any suitable means including memory sharing, message passing, token passing, network transmission, etc.

[00115] The various illustrative logical blocks, modules, circuits, elements, and/or components described in connection with the examples disclosed herein may be implemented or performed with a general purpose processor, a digital signal processor (DSP), an application specific integrated circuit (ASIC), a field programmable gate array (FPGA) or other programmable logic component, discrete gate or transistor logic, discrete hardware components, or any combination thereof designed to perform the

functions described herein. A general purpose processor may be a microprocessor, but in the alternative, the processor may be any conventional processor, controller, microcontroller, or state machine. A processor may also be implemented as a combination of computing components, e.g., a combination of a DSP and a microprocessor, a number of microprocessors, one or more microprocessors in conjunction with a DSP core, or any other such configuration.

**[00116]** The methods or algorithms described in connection with the examples disclosed herein may be embodied directly in hardware, in a software module executable by a processor, or in a combination of both, in the form of processing unit, programming instructions, or other directions, and may be contained in a single device or distributed across multiple devices. A software module may reside in RAM memory, flash memory, ROM memory, EPROM memory, EEPROM memory, registers, hard disk, a removable disk, a CD-ROM, or any other form of storage medium known in the art. A storage medium may be coupled to the processor such that the processor can read information from, and write information to, the storage medium. In the alternative, the storage medium may be integral to the processor.

**[00117]** Those of skill in the art would further appreciate that the various illustrative logical blocks, modules, circuits, and algorithm steps described in connection with the embodiments disclosed herein may be implemented as electronic hardware, computer software, or combinations of both. To clearly illustrate this interchangeability of hardware and software, various illustrative components, blocks, modules, circuits, and steps have been described above generally in terms of their functionality. Whether such functionality is implemented as hardware or software depends upon the particular application and design constraints imposed on the overall system.

**[00118]** The various features of the invention described herein can be implemented in different systems without departing from the invention. It should be noted that the foregoing embodiments are merely examples and are not to be construed as limiting the invention. The description of the embodiments is intended to be illustrative, and not to limit the scope of the claims. As such, the present teachings can be readily applied to other types of apparatuses and many alternatives, modifications, and variations will be apparent to those skilled in the art.

**CLAIMS****WHAT IS CLAIMED IS:**

1. A method for performing multi-wire signaling encoding, comprising:  
converting a sequence of data bits into a plurality of  $m$  transition numbers;  
converting each transition number into a sequential number from a set of sequential numbers;  
converting the sequential number into a raw symbol; and  
transmitting the raw symbol via a plurality of differential drivers and spread over a plurality of  $n$  wires, wherein the clock signal is effectively embedded in the transmission of raw symbols since the conversion from transition number into a sequential number guarantees that no two consecutive raw symbols are the same.
2. The method of claim 1, wherein converting each transition number into a sequential number from a set of sequential numbers includes  
converting a plurality of transition numbers into a sequential number.
3. The method of claim 1, wherein converting the sequential number into a raw symbol includes  
converting the sequential number into a plurality of raw symbols.
4. The method of claim 1, where the plurality of  $n$  wires is greater than or equal to
5. The method of claim 1, where the plurality of  $n$  wires is greater than or equal to
6. The method of claim 1, wherein the raw symbol is guaranteed to have a non-zero differential voltage across all pairs of the plurality of  $n$  wires.
7. The method of claim 1, wherein for an  $n$  factorial differential signal across the pairs of the  $n$  wires,  $r^m$  possible different states are represented by the transition numbers, where  $r$  is  $n!-1$ .

8. The method of claim 1, wherein the sequential number is selected from transition number based on a transition from an immediately previous sequential symbol number.
9. The method of claim 1, further comprising:  
synchronizing raw symbol transmissions using the clock signal.
10. An encoding circuit for performing multi-wire signaling encoding, comprising:  
a bits-to-transition number converter for converting a sequence of data bits into a plurality of m transition numbers;  
a transition number-to-sequential number converter for converting each transition number into a sequential number from a set of sequential numbers;  
a sequential number-to-raw symbol converter for converting the sequential number into a raw symbol; and  
a plurality of differential drivers for transmitting the raw symbol spread over a plurality of n wires, wherein a clock signal is effectively embedded in the transmission of raw symbols since the conversion from transition number into a sequential number guarantees that no two consecutive raw symbols are the same.
11. The encoding circuit of claim 10, wherein converting each transition number into a sequential number from a set of sequential numbers includes converting a plurality of transition numbers into a sequential number.
12. The encoding circuit of claim 10, wherein converting the sequential number into a raw symbol includes converting the sequential number into a plurality of raw symbols.
13. The encoding circuit of claim 10, where the plurality of n wires is greater than or equal to 3.
14. The encoding circuit of claim 10, where the plurality of n wires is greater than or equal to 4.
15. The encoding circuit of claim 10, wherein the raw symbol is guaranteed to have a non-zero differential voltage across all pairs of the n wires.

16. The encoding circuit of claim 10, wherein for an  $n$  factorial differential signal across pairs of the  $n$  wires,  $r^m$  possible different states are represented by the transition numbers, where  $r$  is  $n!-1$ .

17. The encoding circuit of claim 10, wherein the plurality of differential drivers is equal to  ${}_nC_2$ , where  ${}_nC_2 = n(n-1)/2$ .

18. The encoding circuit of claim 10, wherein the plurality of differential drivers is equal to  $n$ .

19. The encoding circuit of claim 10, wherein the sequential number is selected from the transition number based on a transition from an immediately previous sequential symbol number.

20. An encoding circuit, comprising:  
means for converting a sequence of data bits into a plurality of  $m$  transition numbers;  
means for converting each transition number into a sequential number from a set of sequential numbers;  
means for converting the sequential number into a raw symbol; and  
means for transmitting the raw symbol via a plurality of differential drivers and spread over a plurality of  $n$  wires, wherein the clock signal is effectively embedded in the transmission of raw symbols since the conversion from transition number into a sequential number guarantees that no two consecutive raw symbols are the same.

21. A method for performing multi-wire signaling decoding, comprising:  
receiving a raw symbol spread over a plurality of  $n$  wires via a plurality of differential receivers;  
converting the raw symbol into a sequential number from a set of sequential numbers;  
converting each sequential number to a transition number;  
converting a plurality of transition numbers into a sequence of data bits; and  
extracting a clock signal from the reception of raw symbols.

22. The method of claim 21, wherein converting each sequential number to a transition number includes  
converting a sequential number into a plurality of transition numbers.
23. The method of claim 21, wherein converting the raw symbol into a sequential number from a set of sequential numbers includes  
converting a plurality of raw symbols into a sequential number.
24. The method of claim 21, where the plurality of n wires is greater than or equal to
25. The method of claim 21, where the plurality of n wires is greater than or equal to
26. The method of claim 21, wherein the raw symbol is guaranteed to have a non-zero differential voltage across all pairs of the n wires.
27. The method of claim 21, wherein for an n factorial differential signaling across the n drivers,  $r^m$  possible different states are represented by the transition numbers, where r is  $n!-1$ .
28. The method of claim 21, wherein the transition number is selected from the sequential number and based on an immediately previous sequential symbol number.
29. The method of claim 21, further comprising:  
synchronizing raw symbol reception using the clock signal.
30. A decoding circuit for performing multi-wire signaling decoding, comprising:  
a plurality of differential receivers to receive a raw symbol spread over a plurality of n wires;  
a raw symbol-to-sequential number converter for converting the raw symbol into a sequential number from a set of sequential numbers;  
a sequential number-to-transition number converter for converting each sequential number to a transition number;

a transition number-to-bits converter for converting a plurality of transition numbers into a sequence of data bits; and

a clock data recovery circuit for extracting a clock signal from the reception of raw symbols.

31. The decoding circuit of claim 30, wherein converting each sequential number to a transition number includes converting a sequential number into a plurality of transition numbers.

32. The decoding circuit of claim 30, wherein converting the raw symbol into a sequential number from a set of sequential numbers includes converting a plurality of raw symbols into a sequential number.

33. The decoding circuit of claim 30, where the plurality of n wires is greater than or equal to 3.

34. The decoding circuit of claim 30, where the plurality of n wires is greater than or equal to 4.

35. The decoding circuit of claim 30, wherein the raw symbol is guaranteed to have a non-zero differential voltage across all pairs of the plurality of n wires.

36. The decoding circuit of claim 30, wherein for an n factorial differential signaling across the n drivers,  $r^m$  possible different states are represented by the transition numbers, where r is  $n!-1$ .

37. The decoding circuit of claim 30, wherein the plurality of differential drivers is equal to  ${}_nC_2$ , where  ${}_nC_2 = n(n-1)/2$ .

38. The decoding circuit of claim 30, wherein the plurality of differential drivers is equal to n.

39. The decoding circuit of claim 30, wherein the transition number is selected from the sequential number and based on an immediately previous sequential symbol number.

40. The decoding circuit of claim 30, wherein raw symbol reception is synchronized using the clock signal.

41. A decoding circuit for performing multi-wire signaling decoding, comprising:  
    means for receiving a raw symbol spread over a plurality of n wires via a plurality of differential receivers;  
    means for converting the raw symbol into a sequential symbol number from a set of sequential symbol numbers;  
    means for converting each sequential symbol number to a transition number; and  
    means for converting a plurality of transition numbers into a sequence of data bits; and  
    means for extracting a clock signal from the reception of raw symbols.

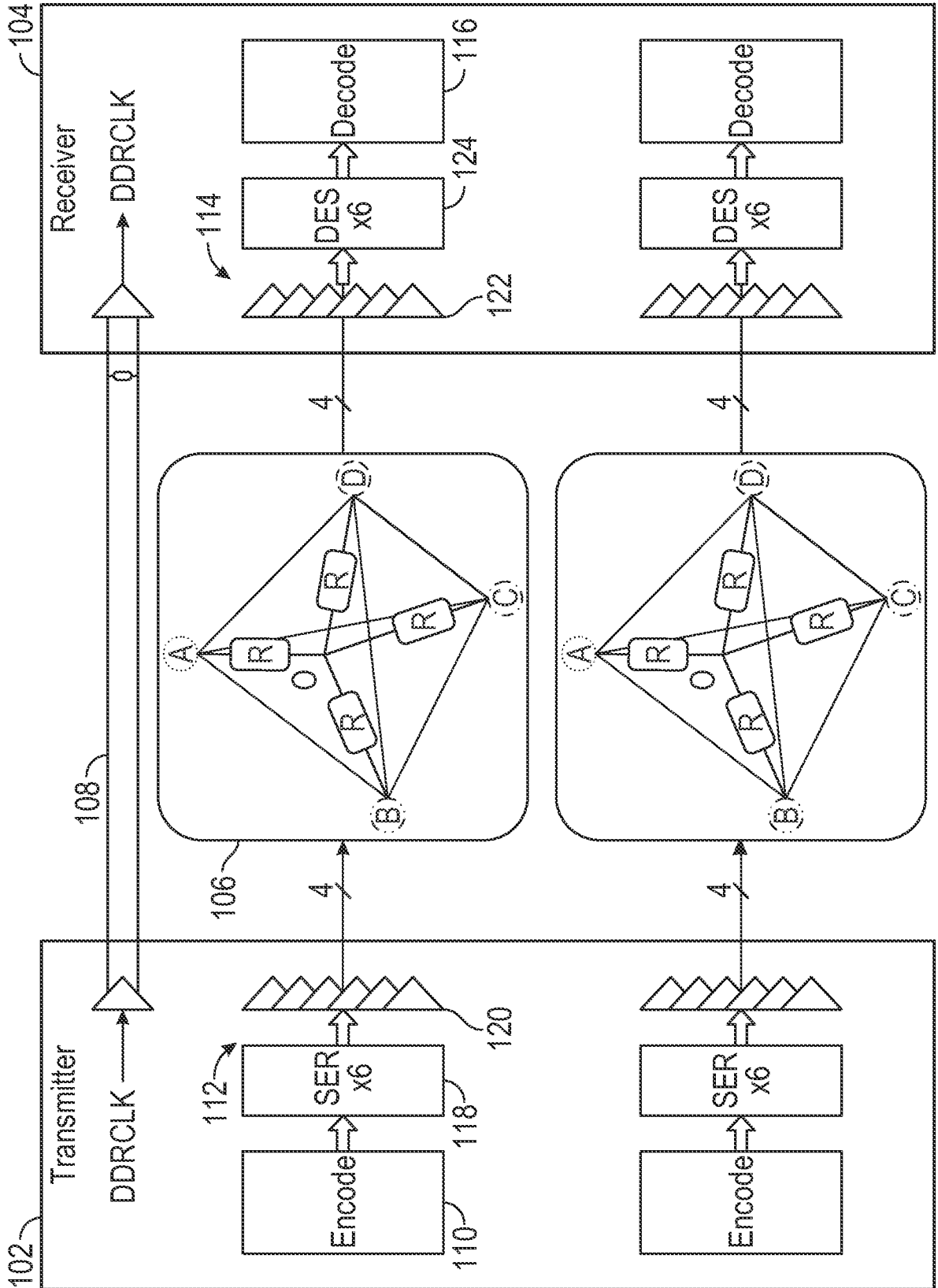

FIG. 1

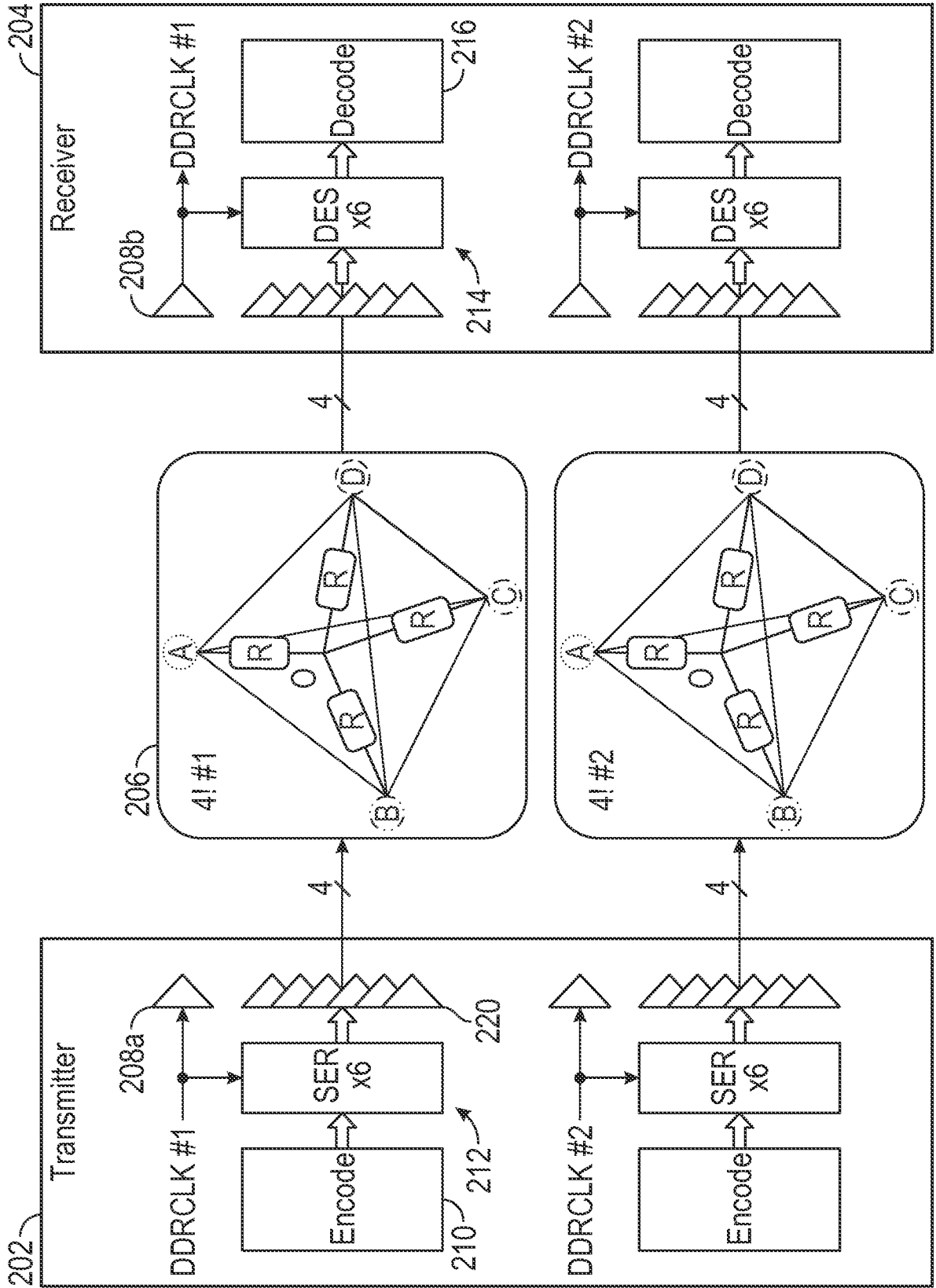

FIG. 2

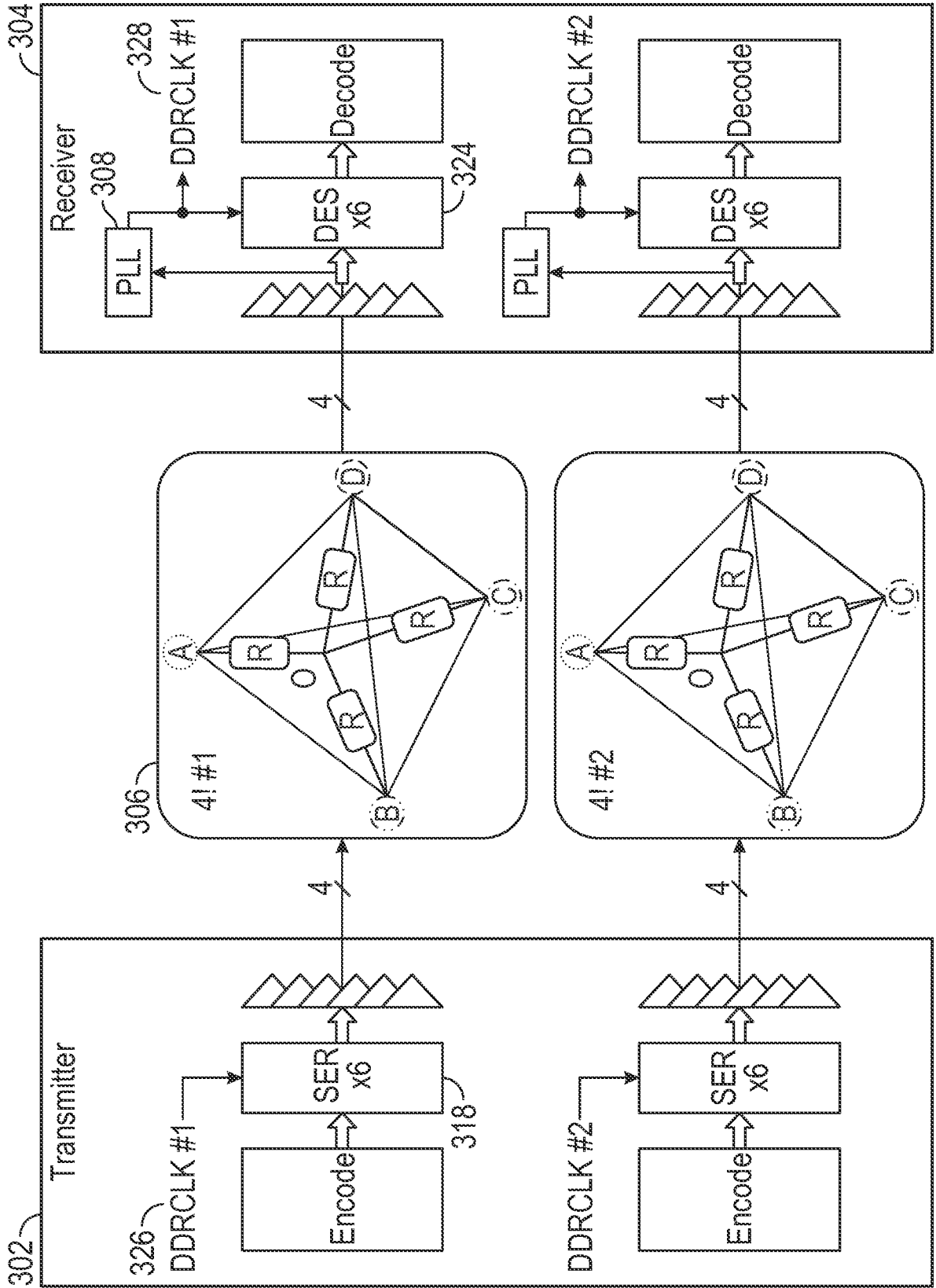

FIG. 3

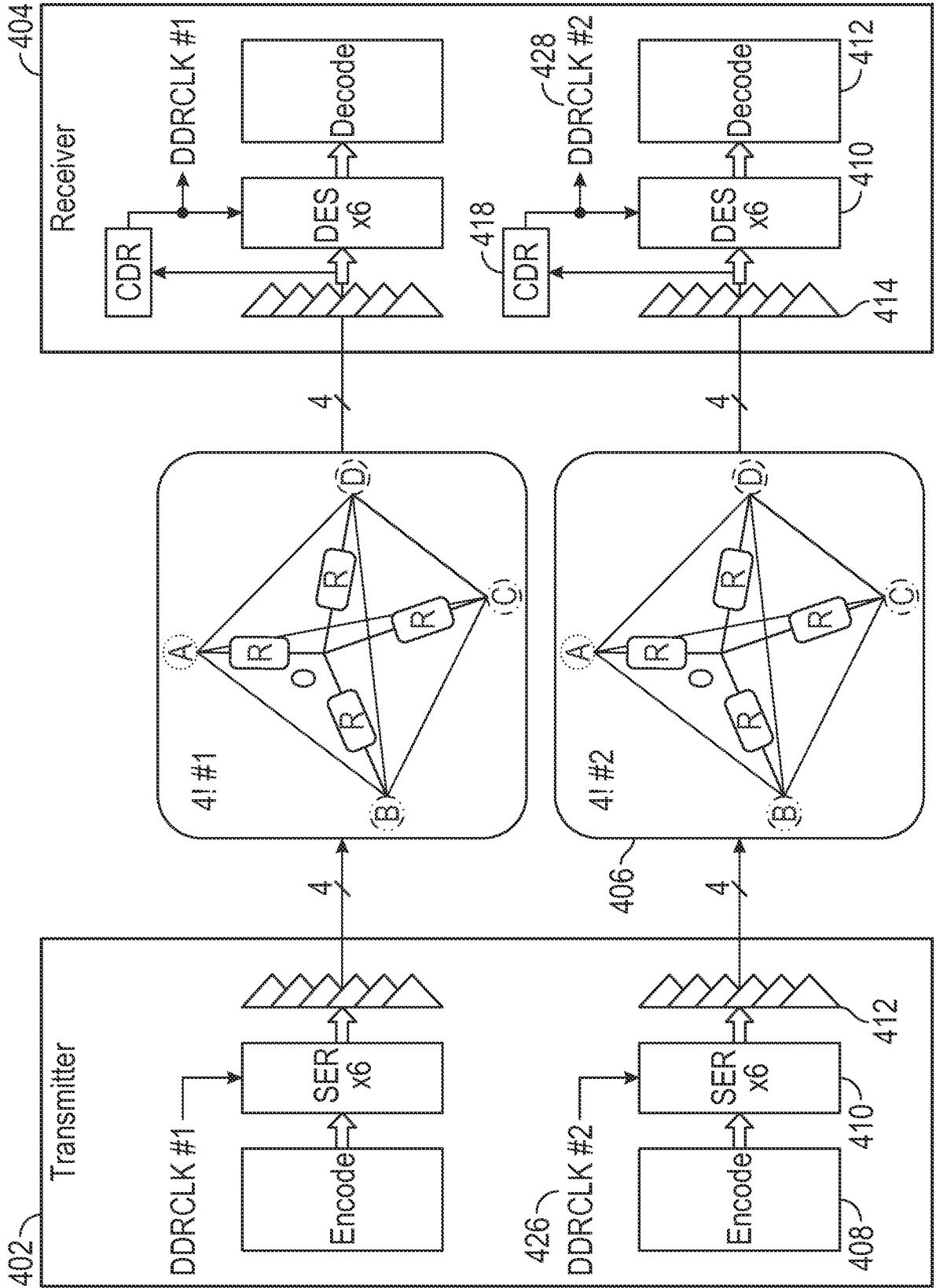

FIG. 4

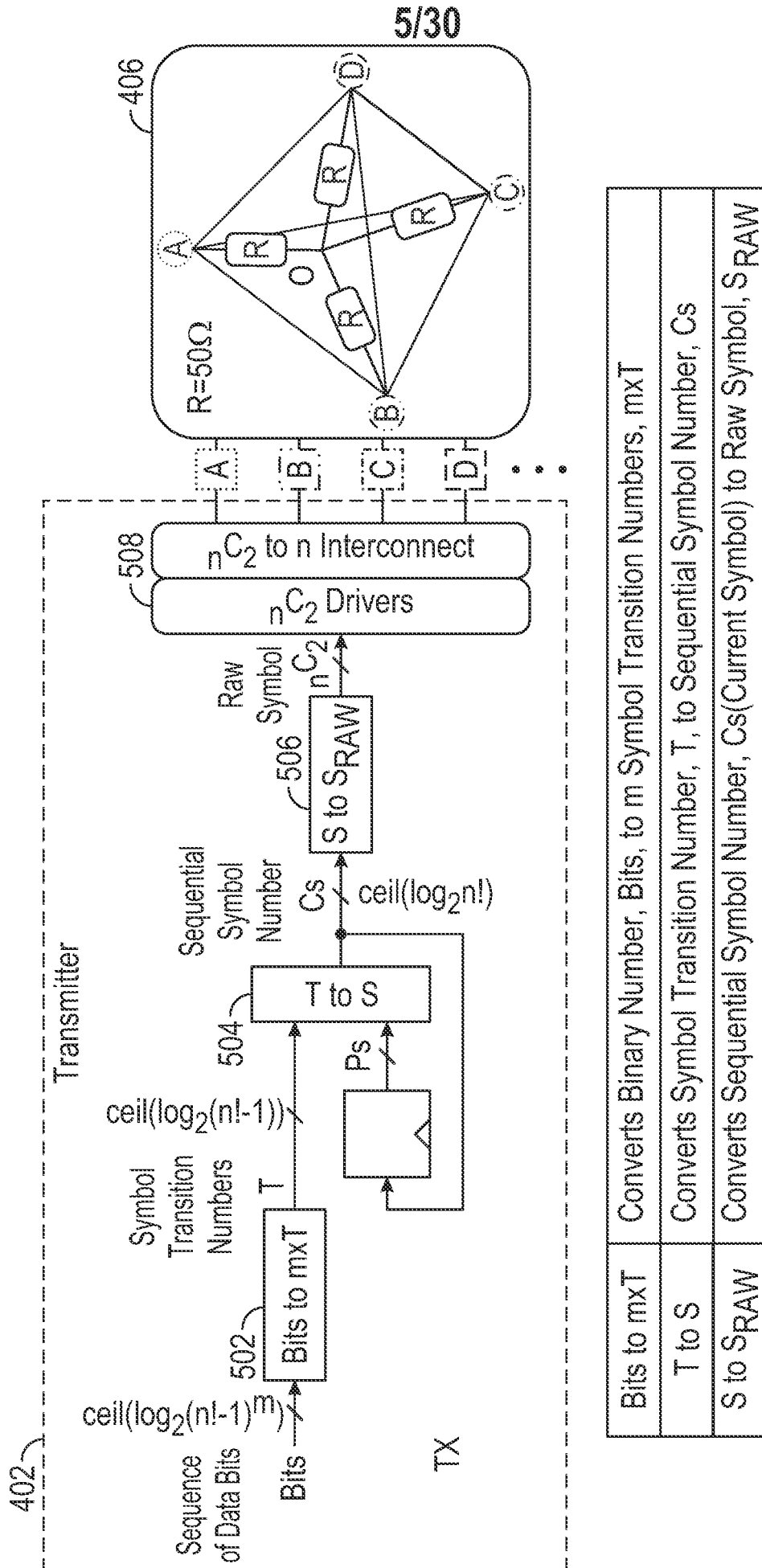
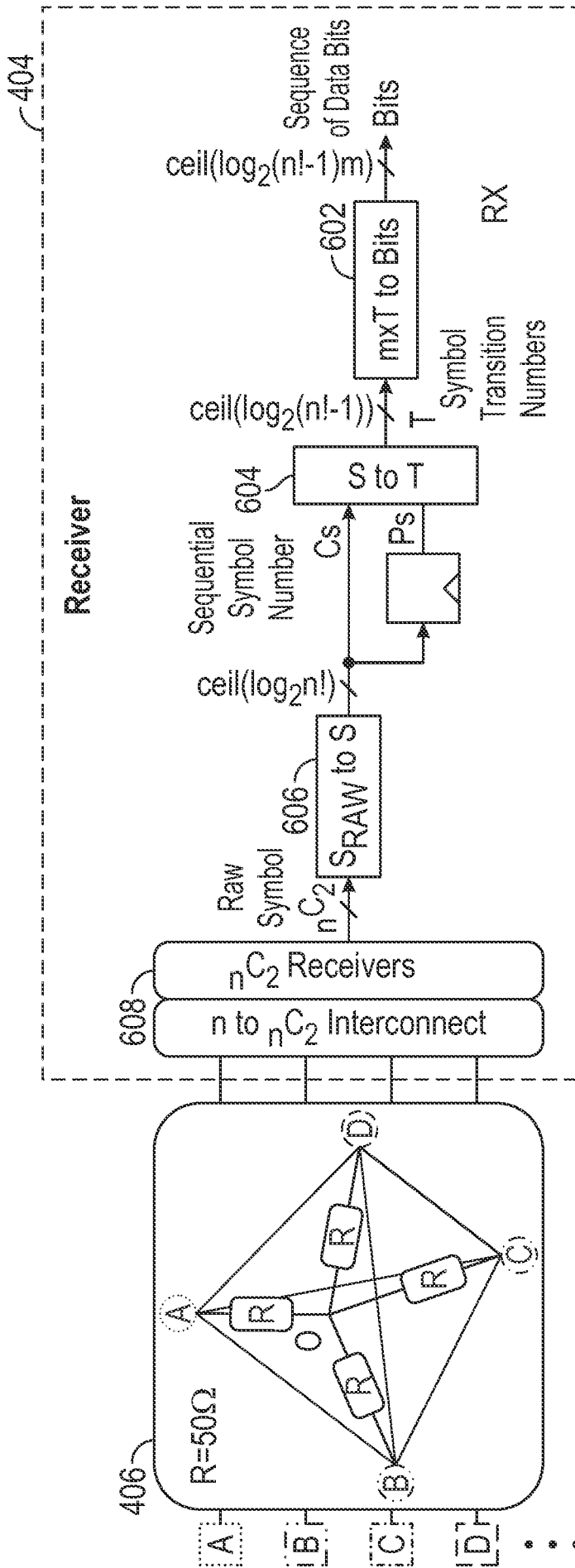

FIG. 5



SRAW to S	Converts Raw Symbol, SRAW, to Sequential Symbol Number, $C_s$ (Current Symbol)
S to T	Converts Sequential Symbol Number, $C_s$ , to Symbol Transition Number, T
mxT to Bits	Converts m Symbol Transition Number, mxT, to Binary Number, Bits

FIG. 6

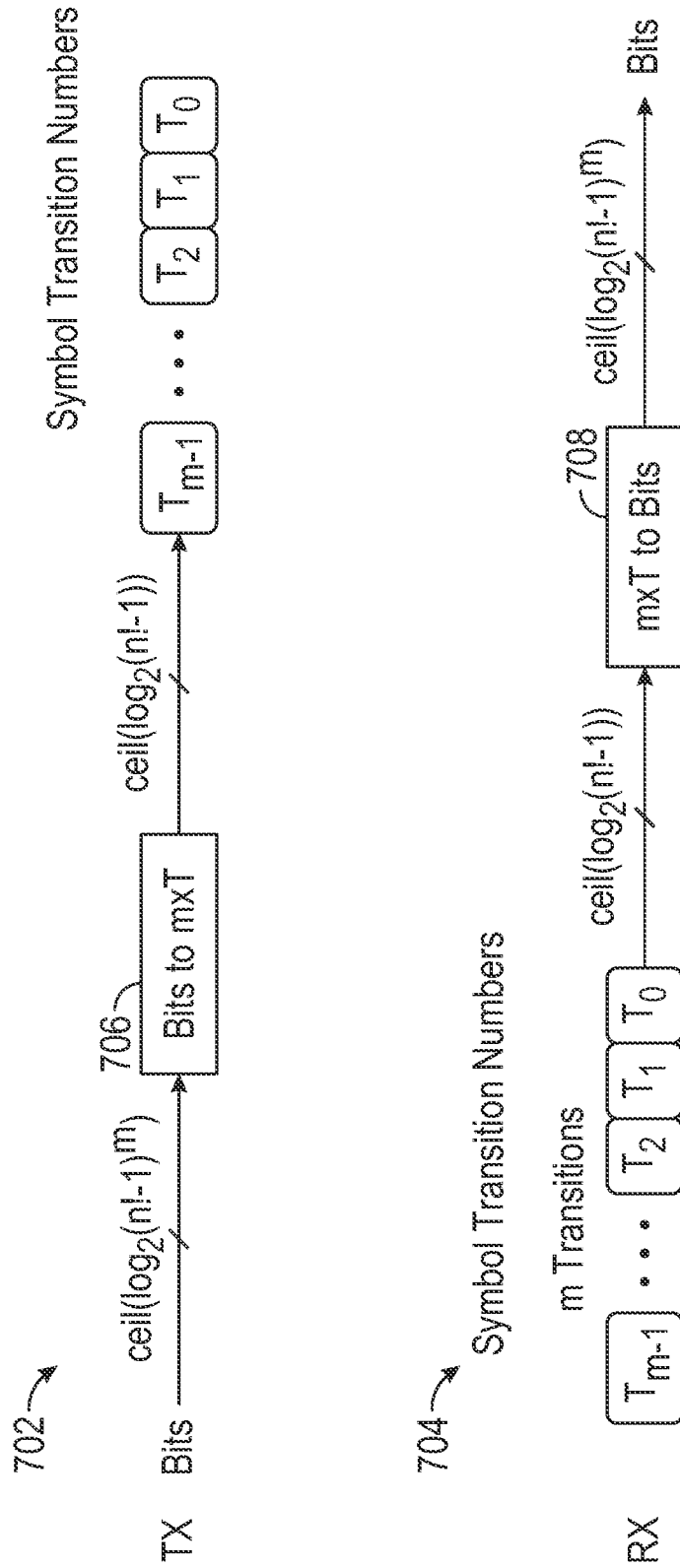

FIG. 7

Sequential Symbol Number 802

Previous Symbol Ps	Current Symbol Cs	Transition Number T
0	1	0
	2	1
	3	2
	4	3
	5	4
1	0	4
	2	0
	3	1
	4	2
	5	3
2	0	3
	1	4
	3	0
	4	1
	5	2
...		
5	0	0
	1	1
	2	2
	3	3
	4	4

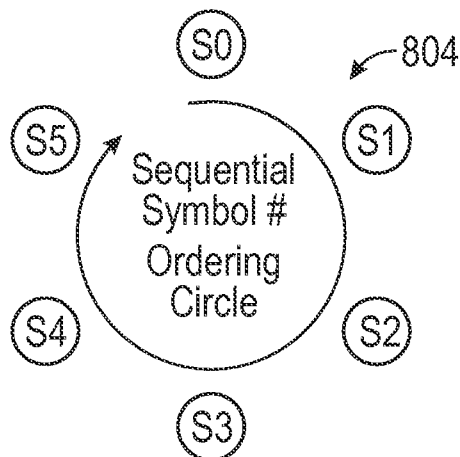

FIG. 8

9/30

Symbol Number Conversion for n=3 is as Simple as:

$$V[2:0]=\{Z,Y,X\}==6 ? 0 : \{Z,Y,X\};$$

$$\{Z,Y,X\}=V[2:0]==0 ? 6 : V[2:0];$$

Raw Symbol			Seq. Symbol #	"3-phase" Symbol	
Z	Y	X	V[2:0]		
1	1	0	0	-x	Only Symbol {Z,Y,X}!=V[2:0]
0	0	1	1	+x	
0	1	0	2	+y	
0	1	1	3	-z	
1	0	0	4	+z	
1	0	1	5	-y	

FIG. 9

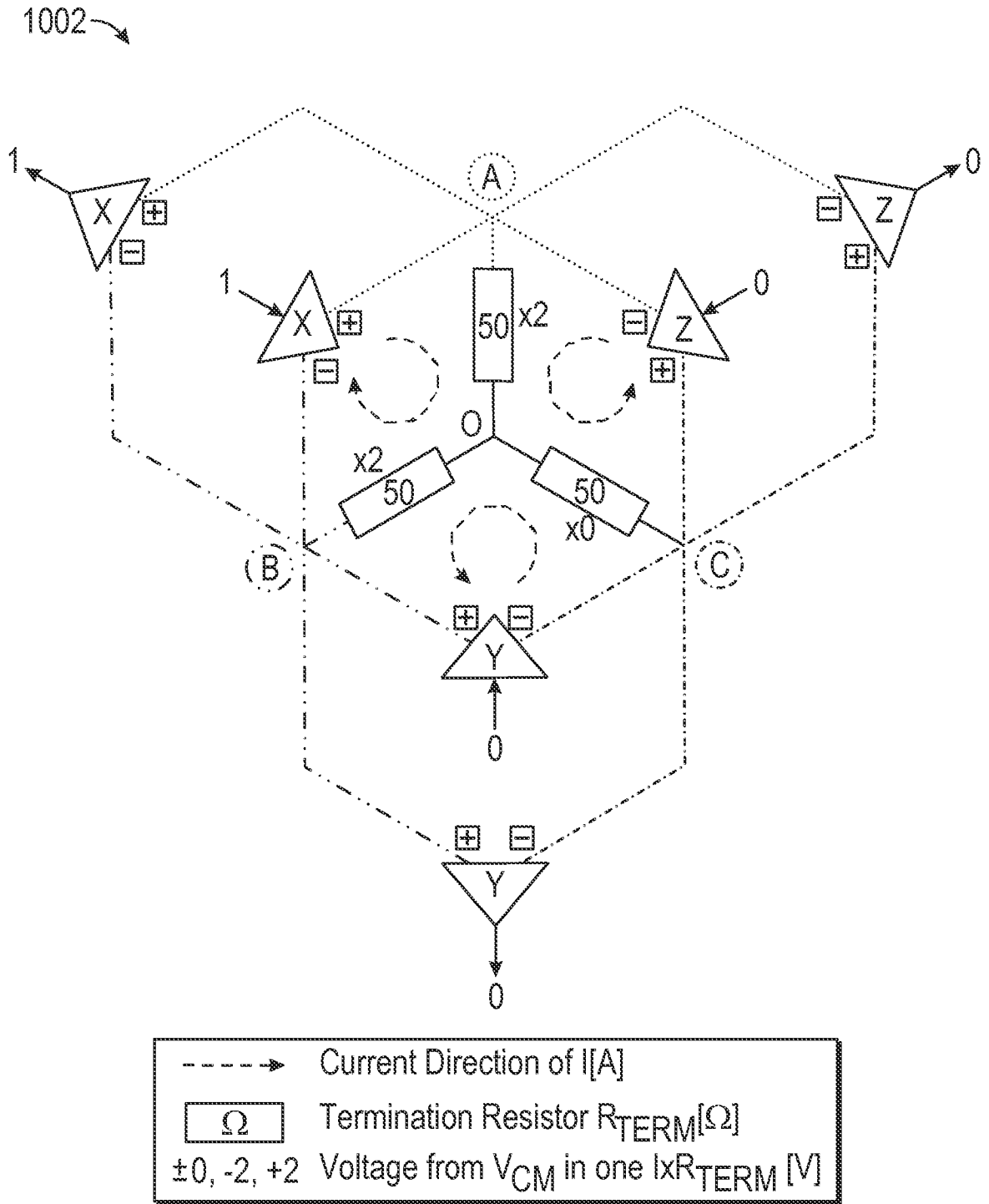

FIG. 10

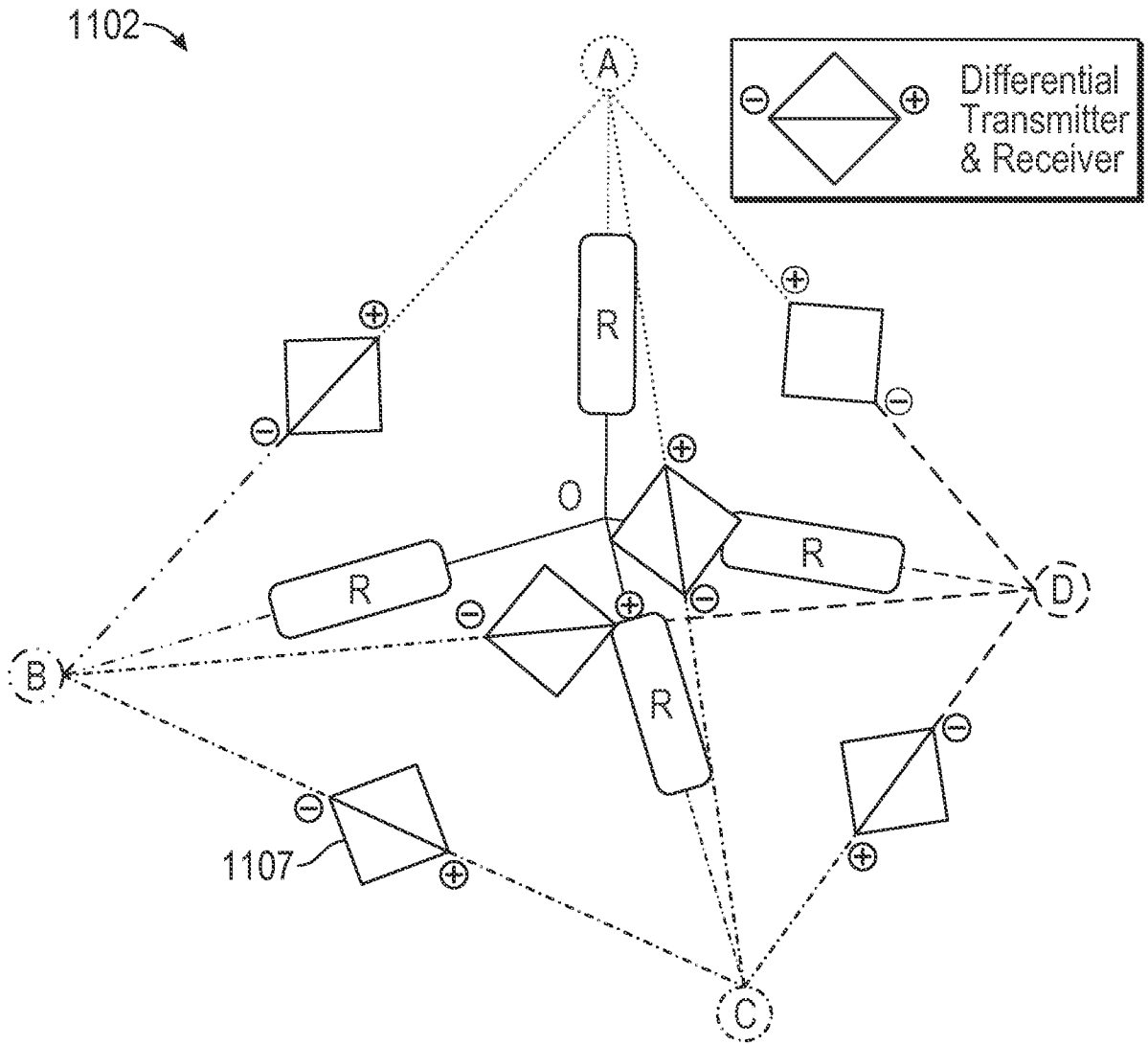
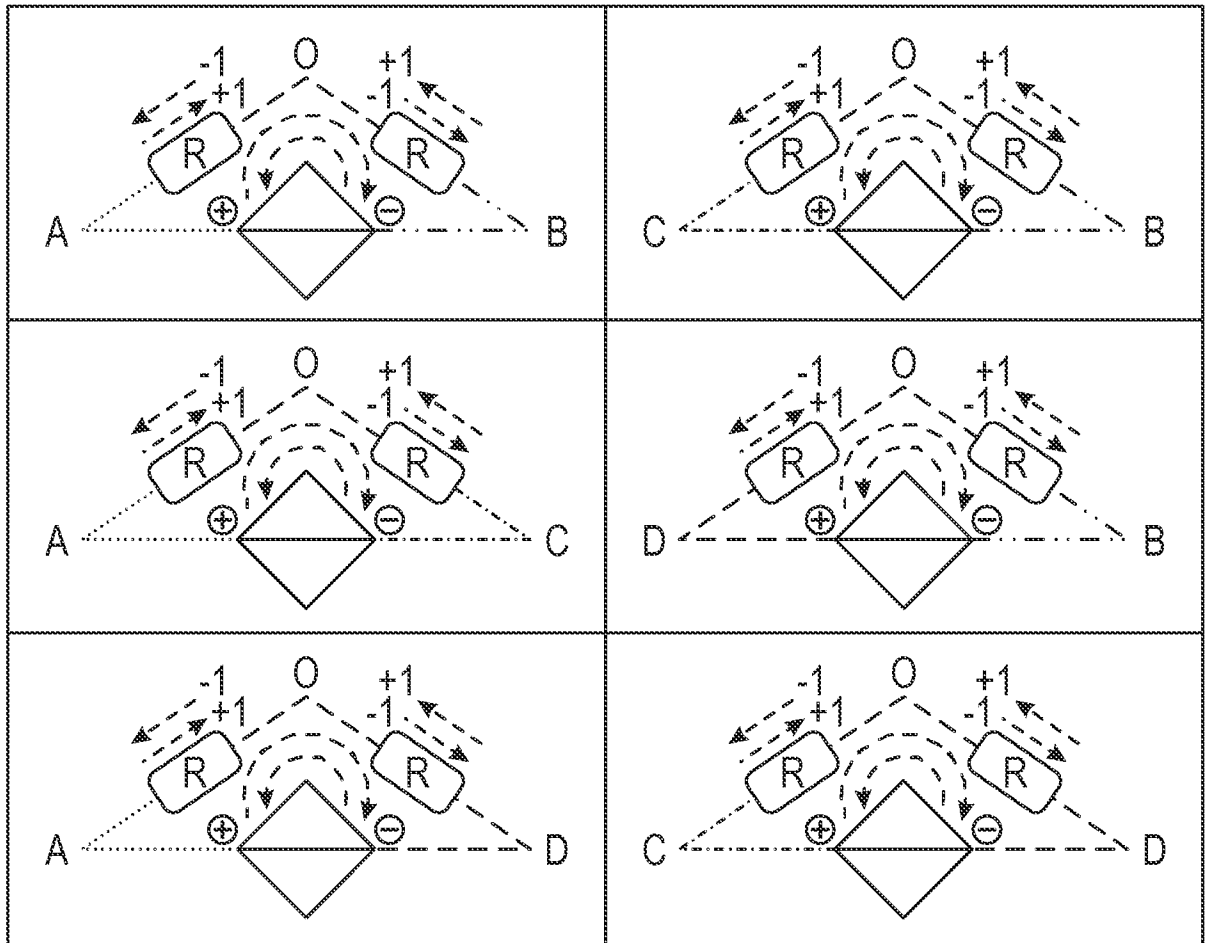

FIG. 11A

1104 ↗



1106 ↗

Tally of Current from Connected Drivers			Possible Total Current at R	
+1	+1	+1	+3	All Drive +1
+1	+1	-1	+1	One Drives -1
+1	-1	-1	-1	One Drive +1
-1	-1	-1	-3	All Drive -1

FIG. 11B

1202 →

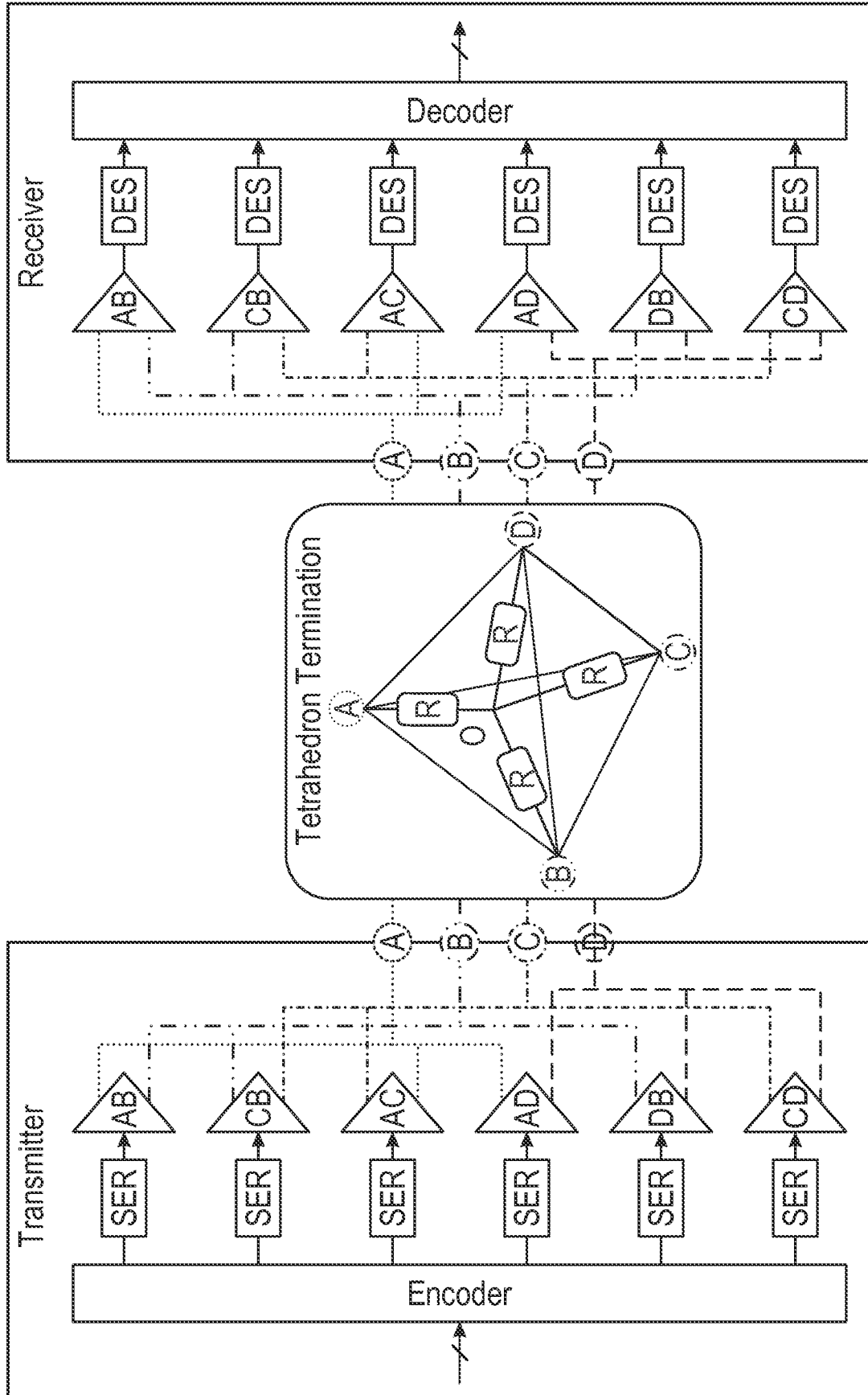

FIG. 12

14/30

Tetrahedron: Differential Voltage per 6-bits Input (1)

S <sub>RAW</sub> (CD, DB, AD, AC, CB, AB)	Voltage at Each R <sub>TERM</sub>				Differential Voltage						0 Diff Level?
	DO	CO	BO	AO	DB	CB	AD	AC	CD	AB	
000000	1	-1	3	-3	-2	-4	-4	-2	-2	-6	
000001	1	-1	1	-1	0	-2	-2	0	-2	-2	Zero
000010	-1	1	3	-3	-4	-2	-2	-4	2	-6	
000011	-1	1	1	-1	-2	0	0	-2	2	-2	Zero
000100	1	-3	3	-1	-2	-6	-2	2	-4	-4	
000101	1	-3	1	1	0	-4	0	4	-4	0	Zero
000110	-1	-1	3	-1	-4	-4	0	0	0	-4	Zero
000111	-1	-1	1	1	-2	-2	2	2	0	0	Zero
001000	-1	-1	3	-1	-4	-4	0	0	0	-4	Zero
001001	-1	-1	1	1	-2	-2	2	2	0	0	Zero
001010	-3	1	3	-1	-6	-2	2	-2	4	-4	
001011	-3	1	1	1	-4	0	4	0	4	0	Zero
001100	-1	-3	3	1	-4	-6	2	4	-2	-2	
001101	-1	-3	1	3	-2	-4	4	6	-2	2	
001110	-3	-1	3	1	-6	-4	4	2	2	-2	
001111	-3	-1	1	3	-4	-2	6	4	2	2	
010000	1	1	1	-3	0	0	-4	-4	0	-4	Zero
010001	1	1	-1	-1	2	2	-2	-2	0	0	Zero
010010	-1	3	1	-3	-2	2	-2	-6	4	-4	
010011	-1	3	-1	-1	0	4	0	-4	4	0	Zero
010100	1	-1	1	-1	0	-2	-2	0	-2	-2	Zero
010101	1	-1	-1	1	2	0	0	2	-2	2	Zero
010110	-1	1	1	-1	-2	0	0	-2	2	-2	Zero
010111	-1	1	-1	1	0	2	2	0	2	2	Zero
011000	-1	1	1	-1	-2	0	0	-2	2	-2	Zero
011001	-1	1	-1	1	0	2	2	0	2	2	Zero
011010	-3	3	1	-1	-4	2	2	-4	6	-2	
011011	-3	3	-1	1	-2	4	4	-2	6	2	
011100	-1	-1	1	1	-2	-2	2	2	0	0	Zero
011101	-1	-1	-1	3	0	0	4	4	0	4	Zero
011110	-3	1	1	1	-4	0	4	0	4	0	Zero
011111	-3	1	-1	3	-2	2	6	2	4	4	

FIG. 13A

Tetrahedron: Differential Voltage per 6-bits Input (2)

S <sub>RAW</sub> (CD, DB, AD, AC, CB, AB)	Voltage at Each R <sub>TERM</sub>				Differential Voltage						0 Diff Level?
	DO	CO	BO	AO	DB	CB	AD	AC	CD	AB	
<del>100000</del>	<del>3</del>	<del>-1</del>	<del>1</del>	<del>-3</del>	<del>2</del>	<del>-2</del>	<del>-6</del>	<del>-2</del>	<del>-4</del>	<del>-4</del>	<del></del>
100001	3	-1	-1	-1	4	0	-4	0	-4	0	Zero
100010	1	1	1	-3	0	0	-4	-4	0	-4	Zero
100011	1	1	-1	-1	2	2	-2	-2	0	0	Zero
<del>100100</del>	<del>3</del>	<del>-3</del>	<del>1</del>	<del>-1</del>	<del>2</del>	<del>-4</del>	<del>-4</del>	<del>2</del>	<del>-6</del>	<del>-2</del>	<del></del>
<del>100101</del>	<del>3</del>	<del>-3</del>	<del>-1</del>	<del>1</del>	<del>4</del>	<del>-2</del>	<del>-2</del>	<del>4</del>	<del>-6</del>	<del>2</del>	<del></del>
100110	1	-1	1	-1	0	-2	-2	0	-2	-2	Zero
100111	1	-1	-1	1	2	0	0	2	-2	2	Zero
101000	1	-1	1	-1	0	-2	-2	0	-2	-2	Zero
101001	1	-1	-1	1	2	0	0	2	-2	2	Zero
101010	-1	1	1	-1	-2	0	0	-2	2	-2	Zero
101011	-1	1	-1	1	0	2	2	0	2	2	Zero
101100	1	-3	1	1	0	-4	0	4	-4	0	Zero
<del>101101</del>	<del>1</del>	<del>-3</del>	<del>-1</del>	<del>3</del>	<del>2</del>	<del>-2</del>	<del>2</del>	<del>6</del>	<del>-4</del>	<del>4</del>	<del></del>
101110	-1	-1	1	1	-2	-2	2	2	0	0	Zero
101111	-1	-1	-1	3	0	0	4	4	0	4	Zero
<del>110000</del>	<del>3</del>	<del>1</del>	<del>-1</del>	<del>-3</del>	<del>4</del>	<del>2</del>	<del>-6</del>	<del>-4</del>	<del>-2</del>	<del>-2</del>	<del></del>
<del>110001</del>	<del>3</del>	<del>1</del>	<del>-3</del>	<del>-1</del>	<del>6</del>	<del>4</del>	<del>-4</del>	<del>-2</del>	<del>-2</del>	<del>2</del>	<del></del>
<del>110010</del>	<del>1</del>	<del>3</del>	<del>-1</del>	<del>-3</del>	<del>2</del>	<del>4</del>	<del>-4</del>	<del>-6</del>	<del>2</del>	<del>-2</del>	<del></del>
<del>110011</del>	<del>1</del>	<del>3</del>	<del>-3</del>	<del>-1</del>	<del>4</del>	<del>6</del>	<del>-2</del>	<del>-4</del>	<del>2</del>	<del>2</del>	<del></del>
110100	3	-1	-1	-1	4	0	-4	0	-4	0	Zero
<del>110101</del>	<del>3</del>	<del>-1</del>	<del>-3</del>	<del>1</del>	<del>6</del>	<del>2</del>	<del>-2</del>	<del>2</del>	<del>-4</del>	<del>4</del>	<del></del>
110110	1	1	-1	-1	2	2	-2	-2	0	0	Zero
110111	1	1	-3	1	4	4	0	0	0	4	Zero
111000	1	1	-1	-1	2	2	-2	-2	0	0	Zero
111001	1	1	-3	1	4	4	0	0	0	4	Zero
111010	-1	3	-1	-1	0	4	0	-4	4	0	Zero
<del>111011</del>	<del>-1</del>	<del>3</del>	<del>-3</del>	<del>1</del>	<del>2</del>	<del>6</del>	<del>2</del>	<del>-2</del>	<del>4</del>	<del>4</del>	<del></del>
111100	1	-1	-1	1	2	0	0	2	-2	2	Zero
<del>111101</del>	<del>1</del>	<del>-1</del>	<del>-3</del>	<del>3</del>	<del>4</del>	<del>2</del>	<del>2</del>	<del>4</del>	<del>-2</del>	<del>6</del>	<del></del>
111110	-1	1	-1	1	0	2	2	0	2	2	Zero
<del>111111</del>	<del>-1</del>	<del>1</del>	<del>-3</del>	<del>3</del>	<del>2</del>	<del>4</del>	<del>4</del>	<del>2</del>	<del>2</del>	<del>6</del>	<del></del>

FIG. 13B

Manually Assigned Raw Symbol  $\leftrightarrow$  Number Conversion Table

S <sub>RAW</sub> (CD, DB, AD, AC, CB, AB)	Voltage at Each R <sub>TERM</sub>				Differential Voltage						S(4:0)
	DO	CO	BO	AO	DB	CB	AD	AC	CD	AB	
010010	-1	3	1	-3	-2	2	-2	-6	4	-4	0x0
001101	-1	-3	1	3	-2	-4	4	6	-2	2	0x1
110010	1	3	-1	-3	2	4	-4	-6	2	-2	0x2
101101	1	-3	-1	3	2	-2	2	6	-4	4	0x3
100000	3	-1	1	-3	2	-2	-6	-2	-4	-4	0x4
001111	-3	-1	1	3	-4	-2	6	4	2	2	0x5
110000	3	1	-1	-3	4	2	-6	-4	-2	-2	0x6
011111	-3	1	-1	3	-2	2	6	2	4	4	0x7
000100	1	-3	3	-1	-2	-6	-2	2	-4	-4	0x8
110011	1	3	-3	-1	4	6	-2	-4	2	2	0x9
001100	-1	-3	3	1	-4	-6	2	4	-2	-2	0xA
111011	-1	3	-3	1	2	6	2	-2	4	4	0xB
001010	-3	1	3	-1	-6	-2	2	-2	4	-4	0xC
110001	3	1	-3	-1	6	4	-4	-2	-2	2	0xD
001110	-3	-1	3	1	-6	-4	4	2	2	-2	0xE
110101	3	-1	-3	1	6	2	-2	2	-4	4	0xF
011010	-3	3	1	-1	-4	2	2	-4	6	-2	0x10
011011	-3	3	-1	1	-2	4	4	-2	6	2	0x11
100100	3	-3	1	-1	2	-4	-4	2	-6	-2	0x12
100101	3	-3	-1	1	4	-2	-2	4	-6	2	0x13
000000	1	-1	3	-3	-2	-4	-4	-2	-2	-6	0x14
111101	1	-1	-3	3	4	2	2	4	-2	6	0x15
000010	-1	1	3	-3	-4	-2	-2	-4	2	-6	0x16
111111	-1	1	-3	3	2	4	4	2	2	6	0x17

Base 16 Symbols "Main"

Alternative symbols "Alt"

FIG. 14

n: Number of Wires  
 r: n!-1 (Radix)  
 m: Number of Symbols per Group  
 $T_k$ : k-1th Transition Number

$$M_m = \text{Bits}$$

$$T_k = M_{k+1} / r^k, M_k = M_{k+1} \% r^k$$

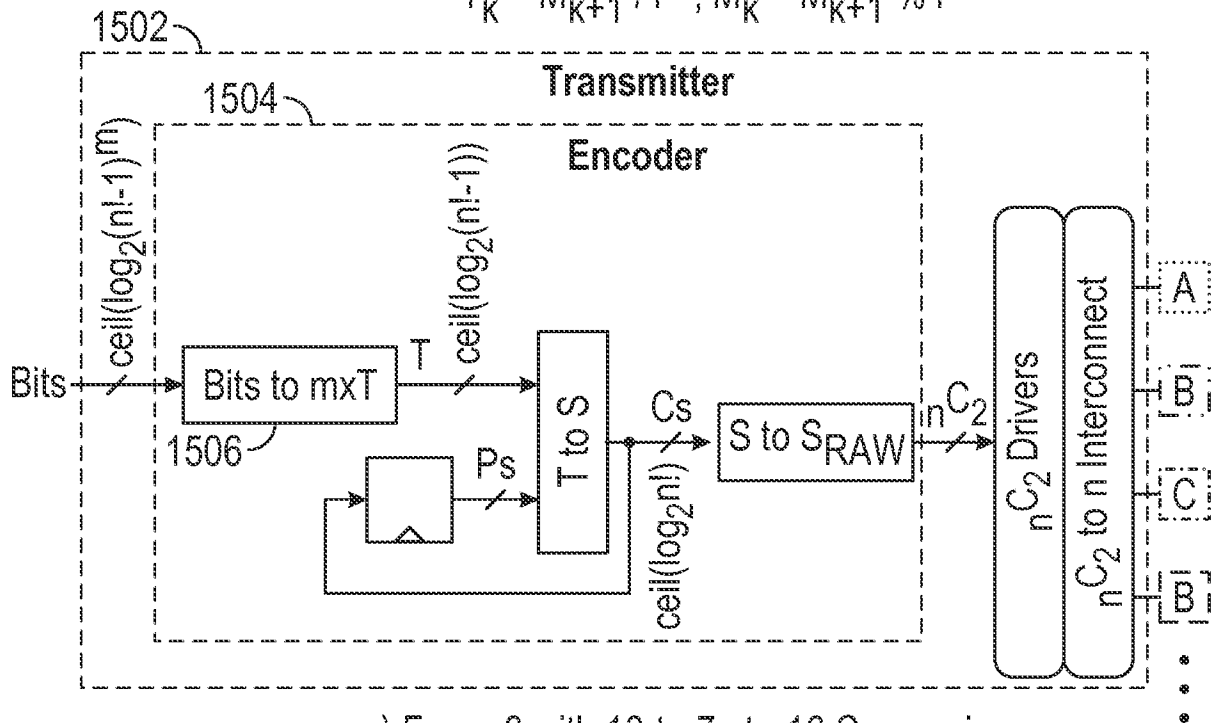

e.g.) For n=3 with 16-to-7s-to-16 Conversion

$$r = 5$$

$$m = 7$$

$$T_6 = \text{Bits} / 5^6, M_6 = \text{Bits} \% 5^6$$

$$T_5 = M_6 / 5^5, M_5 = M_6 \% 5^5$$

$$T_4 = M_5 / 5^4, M_4 = M_5 \% 5^4$$

$$T_3 = M_4 / 5^3, M_3 = M_4 \% 5^3$$

$$T_2 = M_3 / 5^2, M_2 = M_3 \% 5^2$$

$$T_1 = M_2 / 5^1, M_1 = M_2 \% 5$$

$$T_0 = M_1$$

FIG. 15

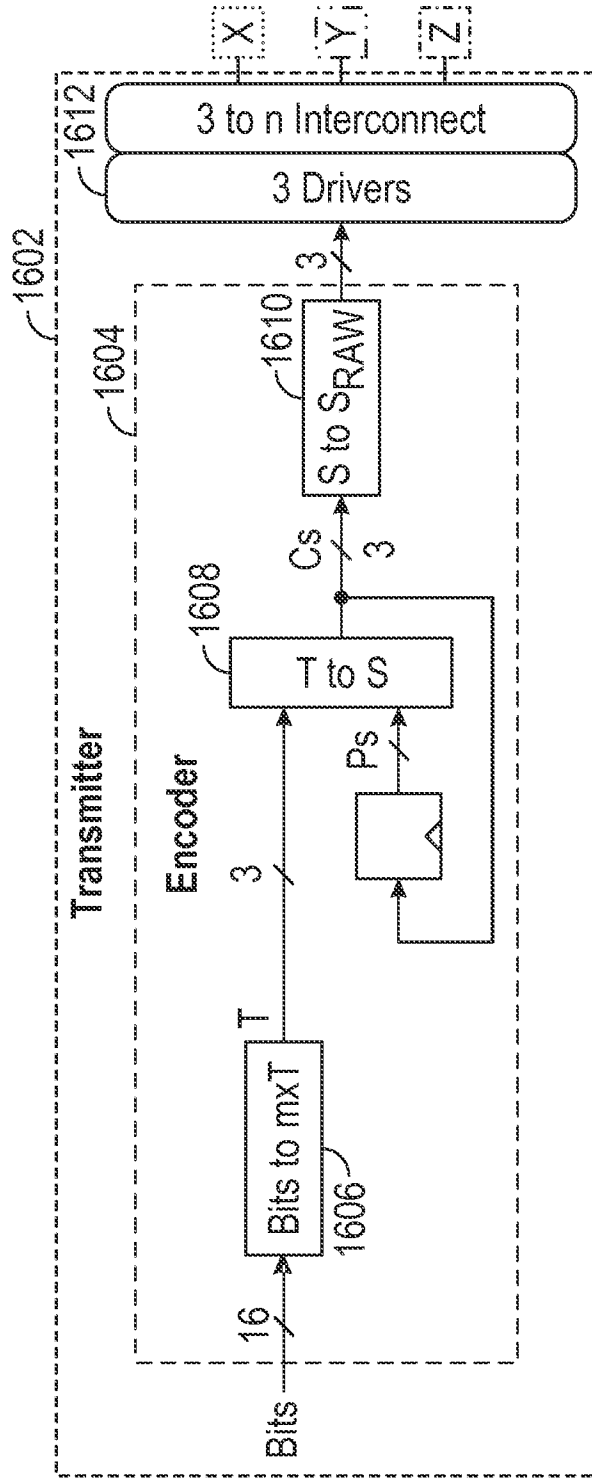

$$\begin{cases}
 T_6 = \text{Bits} / 5^6, M_6 = \text{Bits} \% 5^6 \\
 T_5 = M_6 / 5^5, M_5 = M_6 \% 5^5 \\
 T_4 = M_5 / 5^4, M_4 = M_5 \% 5^4 \\
 T_3 = M_4 / 5^3, M_3 = M_4 \% 5^3 \\
 T_2 = M_3 / 5^2, M_2 = M_3 \% 5^2 \\
 T_1 = M_2 / 5^1, M_1 = M_2 \% 5 \\
 T_0 = M_1
 \end{cases}$$

Quinary (Base-5) Number

$$Cs = Ps+1 + T < 6 ? Ps+1 + T : Ps+1 + T-6$$

$$\text{Symbol}_{\text{raw}} = Cs == 0 ? 6 : Cs$$

FIG. 16

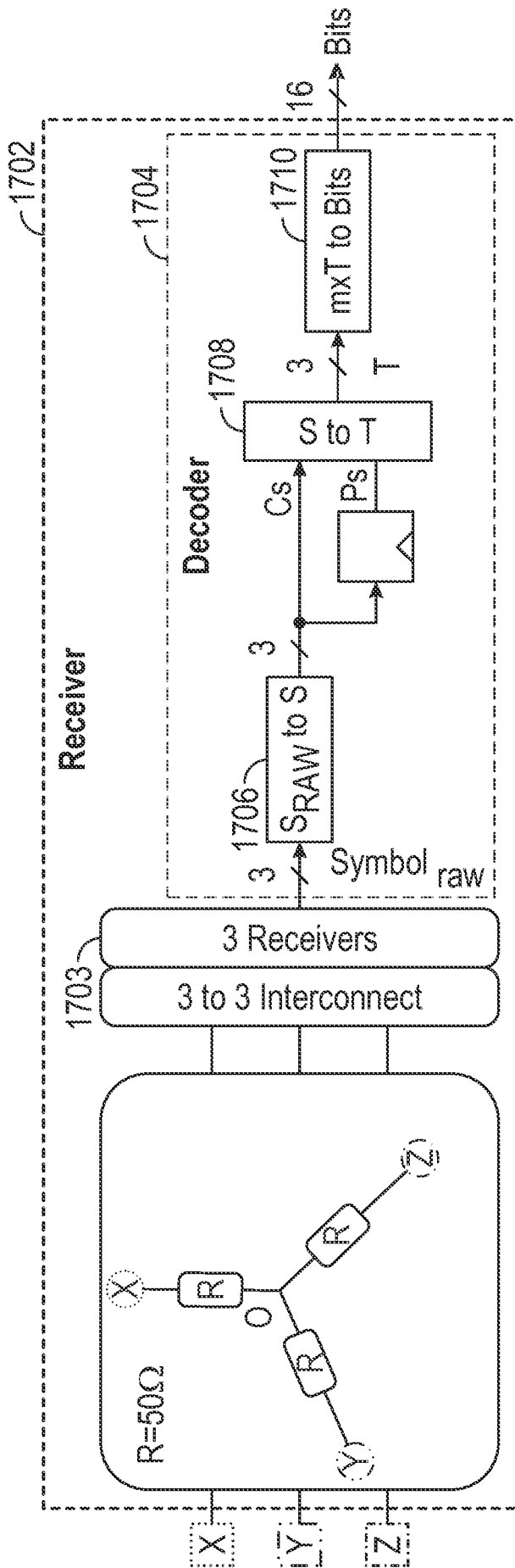

$$Cs = \text{Symbol\_raw} \ll 6 \text{ ? } 0 : \text{Symbol\_raw}$$

$$T = Ps+1 < Cs \text{ ? } Cs - (Ps+1) : Cs - (Ps+1) + 6$$

$$\begin{aligned} \text{Bits} &= T_6 \times 5^6 + T_5 \times 5^5 + T_4 \times 5^4 + T_3 \times 5^3 + T_2 \times 5^2 + T_1 \times 5 + T_0 \\ &= T_6 \times 0 \times 3 \text{D}09 + T_5 \times 0 \times \text{C}35 + T_4 \times 0 \times 271 + T_3 \times 0 \times 7\text{D} + T_2 \times 0 \times 19 + T_1 \times 0 \times 5 + T_0 \end{aligned}$$

FIG. 17



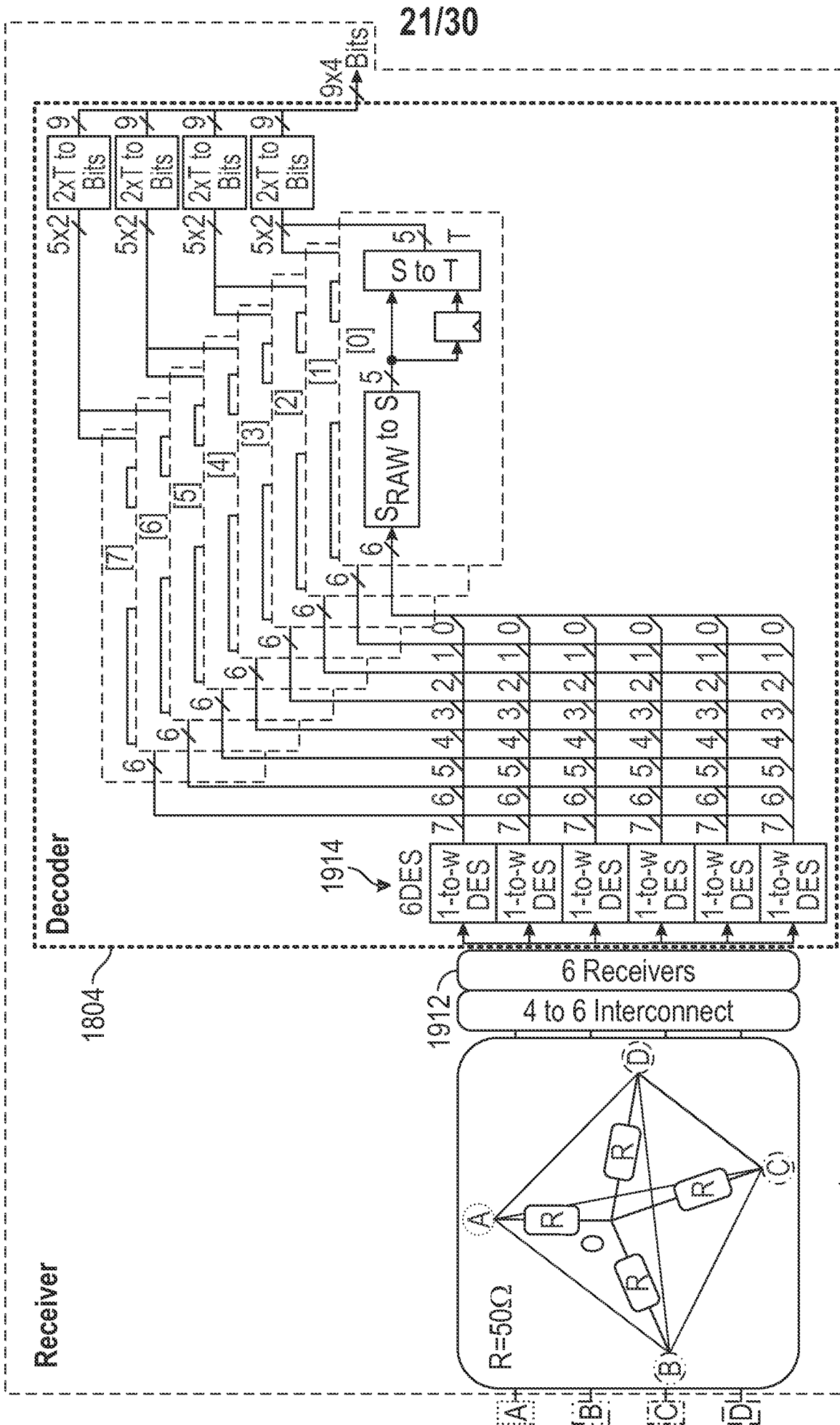

FIG. 19

22/30

n	Utilization %	Symbol /group	Bits/group	Int(bpg)	Bits/cycle	Bits/wire	Bits/wire x2
3	99.98	28	65.0140	65	2.3214	0.7738	1.5476
3	99.92	25	58.0482	58	2.3200	0.7733	1.5467
3	99.84	22	51.0824	51	2.3182	0.7727	1.5455
3	99.74	19	44.1166	44	2.3158	0.7719	1.5439
3	99.59	32	74.3017	74	2.3125	0.7708	1.5417
3	99.59	16	37.1508	37	2.3125	0.7708	1.5417
3	99.50	29	67.3359	67	2.3103	0.7701	1.5402
3	99.39	26	60.3701	60	2.3077	0.7692	1.5385
3	99.39	13	30.1851	30	2.3077	0.7692	1.5385
3	99.24	23	53.4043	53	2.3043	0.7681	1.5362
3	99.06	30	69.6578	69	2.3000	0.7667	1.5333
3	99.06	20	46.4386	46	2.3000	0.7667	1.5333
3	99.06	10	23.2193	23	2.3000	0.7667	1.5333
3	98.90	27	62.6921	62	2.2963	0.7654	1.5309
3	98.80	17	39.4728	39	2.2941	0.7647	1.5294
3	98.70	24	55.7263	55	2.2917	0.7639	1.5278
3	98.64	31	71.9798	71	2.2903	0.7634	1.5269
3	98.44	21	48.7605	48	2.2857	0.7619	1.5238
3	98.44	14	32.5070	32	2.2857	0.7619	1.5238
3	98.44	7	16.2535	16	2.2857	0.7619	1.5238
3	98.10	18	41.7947	41	2.2778	0.7593	1.5185
3	97.88	11	25.5412	25	2.2727	0.7576	1.5152
3	97.62	15	34.8289	34	2.2667	0.7556	1.5111
3	96.90	12	27.8631	27	2.2500	0.7500	1.5000
3	96.90	8	18.5754	18	2.2500	0.7500	1.5000
3	96.90	4	9.2877	9	2.2500	0.7500	1.5000
3	95.71	9	20.8974	20	2.2222	0.7407	1.4815
3	94.75	5	11.6096	11	2.2000	0.7333	1.4667
3	93.31	6	13.9316	13	2.1667	0.7222	1.4444
3	86.14	3	6.9658	6	2.0000	0.6667	1.3333
3	86.14	2	4.6439	4	2.0000	0.6667	1.3333
3	86.14	1	2.3219	2	2.0000	0.6667	1.3333

FIG. 20

## 23/30

n	Utilization %	Symbol /group	Bits/group	Int(bpg)	Bits/cycle	Bits/wire	Bits/wire x2
4	99.96	23	104.0419	104	4.5217	1.1304	2.2609
4	99.92	25	113.0890	113	4.5200	1.1300	2.2600
4	99.89	27	122.1362	122	4.5185	1.1296	2.2593
4	99.86	29	131.1833	131	4.5172	1.1293	2.2586
4	99.84	31	140.2304	140	4.5161	1.1290	2.2581
4	99.48	32	144.7540	144	4.5000	1.1250	2.2500
4	99.48	30	135.7069	135	4.5000	1.1250	2.2500
4	99.48	28	126.6597	126	4.5000	1.1250	2.2500
4	99.48	26	117.6126	117	4.5000	1.1250	2.2500
4	99.48	24	108.5655	108	4.5000	1.1250	2.2500
4	99.48	22	99.5184	99	4.5000	1.1250	2.2500
4	99.48	20	90.4712	90	4.5000	1.1250	2.2500
4	99.48	18	81.4241	81	4.5000	1.1250	2.2500
4	99.48	16	72.3770	72	4.5000	1.1250	2.2500
4	99.48	14	63.3299	63	4.5000	1.1250	2.2500
4	99.48	12	54.2827	54	4.5000	1.1250	2.2500
4	99.48	10	45.2356	45	4.5000	1.1250	2.2500
4	99.48	8	36.1885	36	4.5000	1.1250	2.2500
4	99.48	6	27.1414	27	4.5000	1.1250	2.2500
4	99.48	4	18.0942	18	4.5000	1.1250	2.2500
4	99.48	2	9.0471	9	4.5000	1.1250	2.2500
4	98.95	21	94.9948	94	4.4762	1.1190	2.2381
4	98.90	19	85.9477	85	4.4737	1.1184	2.2368
4	98.83	17	76.9006	76	4.4706	1.1176	2.2353
4	98.74	15	67.8534	67	4.4667	1.1167	2.2333
4	98.63	13	58.8063	58	4.5615	1.1154	2.2308
4	98.47	11	49.7592	49	4.4545	1.1136	2.2273
4	98.25	9	40.7121	40	4.4444	1.1111	2.2222
4	97.90	7	31.6649	31	4.4286	1.1071	2.2143
4	97.27	5	22.6178	22	4.4000	1.1000	2.2000
4	95.79	3	13.5707	13	4.3333	1.0833	2.1667
4	88.43	1	4.5236	4	4.0000	1.0000	2.0000

FIG. 21

## 24/30

n	Utilization %	Symbol /group	Bits/group	Int(bpg)	Bits/cycle	Bits/wire	Bits/wire x2
5	100.00	19	131.0015	131	6.8947	1.3789	2.7579
5	99.97	28	193.0549	193	6.8929	1.3786	2.7571
5	99.91	27	186.1601	186	6.8889	1.3778	2.7556
5	99.91	18	124.1067	124	6.8889	1.3778	2.7556
5	99.91	9	62.0534	62	6.8889	1.3778	2.7556
5	99.85	26	179.2653	179	6.8846	1.3769	2.7538
5	99.82	17	117.2119	117	6.8824	1.3765	2.7529
5	99.79	25	172.3704	172	6.8800	1.3760	2.7520
5	99.71	32	220.6342	220	6.8750	1.3750	2.7500
5	99.71	24	165.4756	165	6.8750	1.3750	2.7500
5	99.71	16	110.3171	110	6.8750	1.3750	2.7500
5	99.71	8	55.1585	55	6.8750	1.3750	2.7500
5	99.65	31	213.7394	213	6.8710	1.3742	2.7484
5	99.63	23	158.5808	158	6.8696	1.3739	2.7478
5	99.59	30	206.8445	206	6.8667	1.3733	2.7467
5	99.59	15	103.4223	103	6.8667	1.3733	2.7467
5	99.55	22	151.6860	151	6.8636	1.3727	2.7455
5	99.53	29	199.9497	199	6.8621	1.3724	2.7448
5	99.45	21	144.7912	144	6.8571	1.3714	2.7429
5	99.45	14	96.5274	96	6.8571	1.3714	2.7429
5	99.45	7	48.2637	48	6.8571	1.3714	2.7429
5	99.35	20	137.8964	137	6.8500	1.3700	2.7400
5	99.29	13	89.6326	89	6.8462	1.3692	2.7385
5	99.11	12	82.7378	82	6.8333	1.3667	2.7333
5	99.11	6	41.3689	41	6.8333	1.3667	2.7333
5	98.89	11	75.8430	75	6.8182	1.3636	2.7273
5	98.62	10	68.9482	68	6.8000	1.3600	2.7200
5	98.62	5	34.4741	34	6.8000	1.3600	2.7200
5	97.90	4	27.5793	27	6.7500	1.3500	2.7000
5	96.69	3	20.6845	20	6.6667	1.3333	2.6667
5	94.27	2	13.7896	13	6.5000	1.3000	2.6000
5	87.02	1	6.8948	6	6.0000	1.2000	2.4000

FIG. 22

## 25/30

n	Utilization %	Symbol /group	Bits/group	Int(bpg)	Bits/cycle	Bits/wire	Bits/wire x2
6	99.94	31	294.1853	294	9.4839	1.5806	3.1613
6	99.93	29	275.2056	275	9.4828	1.5805	3.1609
6	99.91	27	256.2259	256	9.4815	1.5802	3.1605
6	99.90	25	237.2462	237	9.4800	1.5800	3.1600
6	99.88	23	218.2665	218	9.4783	1.5797	3.1594
6	99.86	21	199.2868	199	9.4762	1.5794	3.1587
6	99.83	19	180.3071	180	9.4737	1.5789	3.1579
6	99.80	17	161.3274	161	9.4706	1.5784	3.1569
6	99.78	32	303.6751	303	9.4688	1.5781	3.1556
6	99.76	30	284.6954	284	9.4667	1.5778	3.1556
6	99.76	15	142.3477	142	9.4667	1.5778	3.1556
6	99.73	28	265.7157	265	9.4643	1.5774	3.1548
6	99.70	26	246.7360	246	9.4615	1.5769	3.1538
6	99.70	13	123.3680	123	9.4615	1.5769	3.1538
6	99.67	24	227.7564	227	9.4583	1.5764	3.1528
6	99.63	22	208.7767	208	9.4545	1.5758	3.1515
6	99.63	11	104.3883	104	9.4545	1.5758	3.1515
6	99.58	20	189.7970	189	9.4500	1.5750	3.1500
6	99.52	18	170.8173	170	9.4444	1.5741	3.1481
6	99.52	9	85.4086	85	9.4444	1.5741	3.1481
6	99.45	16	151.8376	151	9.4375	1.5729	3.1458
6	99.35	14	132.8579	132	9.4286	1.5714	3.1429
6	99.35	7	66.4289	66	9.4286	1.5714	3.1429
6	99.23	12	113.8782	113	9.4167	1.5694	3.1389
6	99.05	10	94.8985	94	9.4000	1.5667	3.1333
6	99.05	5	47.4492	47	9.4000	1.5667	3.1333
6	98.79	8	75.9188	75	9.3750	1.5625	3.1250
6	98.35	6	56.9391	56	9.3333	1.5556	3.1111
6	98.35	3	28.4695	28	9.3333	1.5556	3.1111
6	97.47	4	37.9594	37	9.2500	1.5417	3.0833
6	94.84	2	18.9797	18	9.0000	1.5000	3.0000
6	94.84	1	9.4898	9	9.0000	1.5000	3.0000

FIG. 23

## 26/30

n	Utilization %	Symbol /group	Bits/group	Int(bpg)	Bits/cycle	Bits/wire	Bits/wire x2
7	99.98	27	332.0709	332	12.2963	1.7566	3.5132
7	99.96	17	209.0817	209	12.2941	1.7563	3.5126
7	99.94	24	295.1741	295	12.2917	1.7560	3.5119
7	99.93	31	381.2666	381	12.2903	1.7558	3.5115
7	99.89	28	344.3698	344	12.2857	1.7551	3.5102
7	99.89	21	258.2774	258	12.2857	1.7551	3.5102
7	99.89	14	172.1849	172	12.2857	1.7551	3.5102
7	99.89	7	86.0925	86	12.2857	1.7551	3.5102
7	99.86	32	393.5655	393	12.2812	1.7545	3.5089
7	99.85	25	307.4730	307	12.2800	1.7543	3.5086
7	99.83	18	221.3806	221	12.2778	1.7540	3.5079
7	99.81	29	356.6687	356	12.2759	1.7537	3.5074
7	99.79	22	270.5763	270	12.2727	1.7532	3.5065
7	99.79	11	135.2881	135	12.2727	1.7532	3.5065
7	99.76	26	319.7720	319	12.2692	1.7527	3.5055
7	99.74	30	368.9677	368	12.2667	1.7524	3.5048
7	99.74	15	184.4838	184	12.2667	1.7524	3.5048
7	99.71	19	233.6795	233	12.2632	1.7519	3.5038
7	99.69	23	282.8752	282	12.2609	1.7516	3.5031
7	99.60	20	245.9784	245	12.2500	1.7500	3.5000
7	99.60	16	196.7827	196	12.2500	1.7500	3.5000
7	99.60	12	147.5871	147	12.2500	1.7500	3.5000
7	99.60	8	98.3914	98	12.2500	1.7500	3.5000
7	99.60	4	49.1957	49	12.2500	1.7500	3.5000
7	99.45	13	159.8860	159	12.2308	1.7473	3.4945
7	99.38	9	110.6903	110	12.2222	1.7460	3.4921
7	99.20	10	122.9892	122	12.2000	1.7429	3.4857
7	99.20	5	61.4946	61	12.2000	1.7429	3.4857
7	98.92	6	73.7935	73	12.1667	1.7381	3.4762
7	97.57	3	36.8968	36	12.0000	1.7143	3.4286
7	97.57	2	24.5978	24	12.0000	1.7143	3.4286
7	97.57	1	12.2989	12	12.0000	1.7143	3.4286

FIG. 24

27/30

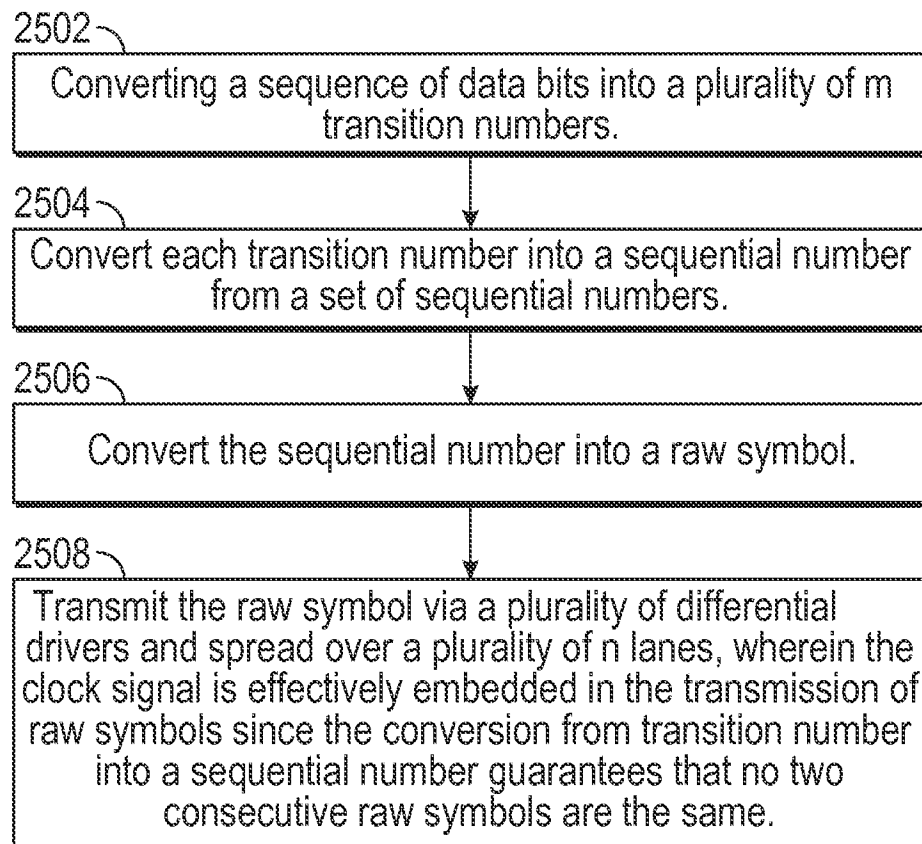

FIG. 25

28/30

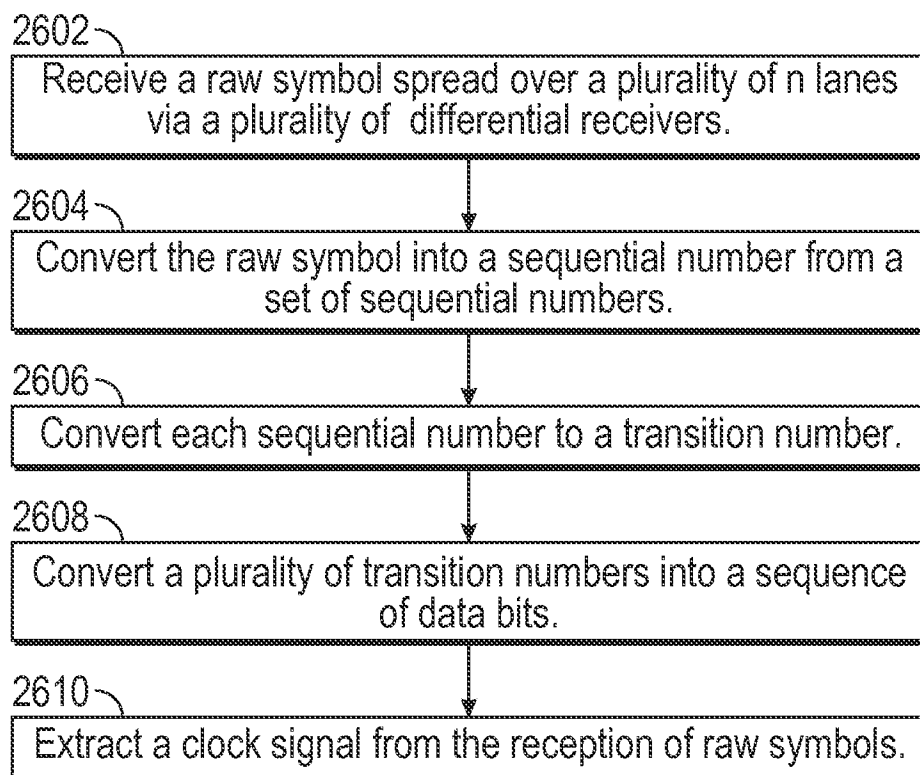
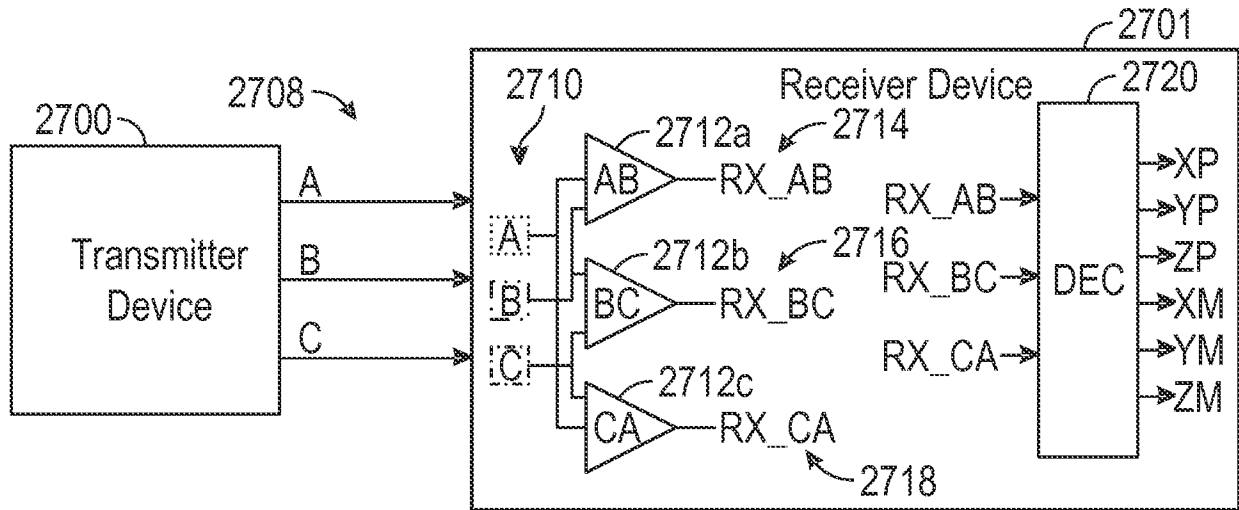

FIG. 26

29/30



States

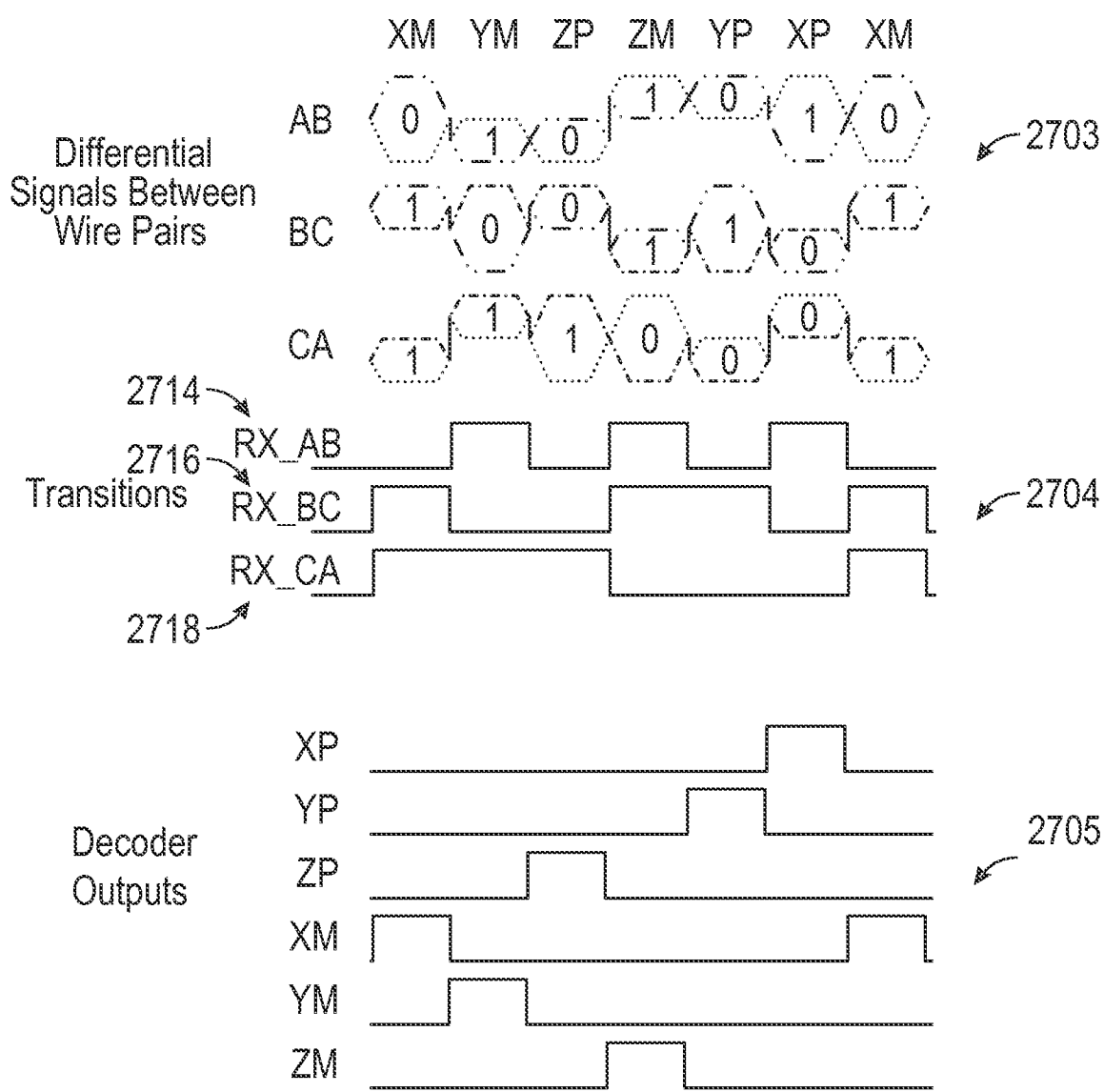

FIG. 27

2802



	# of wires / pins	# of states per cycle	Bits per cycle	# of drivers / receivers	# of differential voltage level
	$n$	$s (= n!)$	$\log_2(s)$	$d (= {}_n C_2)$	$n-1$
N Factorial N!	3	6	2.58	3	2
	4	24	4.58	6	3
	5	120	6.91	10	4
	6	720	9.49	15	5

**FIG. 28**

# INTERNATIONAL SEARCH REPORT

International application No PCT/US2014/021979
---------------------------------------------------

**A. CLASSIFICATION OF SUBJECT MATTER**  
 INV. H04L25/49 H04L25/493  
 ADD. H04L25/02

According to International Patent Classification (IPC) or to both national classification and IPC

**B. FIELDS SEARCHED**

Minimum documentation searched (classification system followed by classification symbols)  
 H04L

Documentation searched other than minimum documentation to the extent that such documents are included in the fields searched

Electronic data base consulted during the international search (name of data base and, where practicable, search terms used)

EPO-Internal, WPI Data

**C. DOCUMENTS CONSIDERED TO BE RELEVANT**

Category*	Citation of document, with indication, where appropriate, of the relevant passages	Relevant to claim No.
X	WO 2008/109478 A2 (QUALCOMM INC [US]; WILEY GEORGE A [US]) 12 September 2008 (2008-09-12) abstract paragraph [0003] paragraph [0034] - paragraph [0042]	1-41
A	----- WO 2008/151251 A1 (RAMBUS INC [US]; WARE FREDERICK A [US]; KIZER JADE) 11 December 2008 (2008-12-11) abstract page 1, line 5 - line 8 claims 1,2 -----	1-41

Further documents are listed in the continuation of Box C.

See patent family annex.

\* Special categories of cited documents :

- "A" document defining the general state of the art which is not considered to be of particular relevance
- "E" earlier application or patent but published on or after the international filing date
- "L" document which may throw doubts on priority claim(s) or which is cited to establish the publication date of another citation or other special reason (as specified)
- "O" document referring to an oral disclosure, use, exhibition or other means
- "P" document published prior to the international filing date but later than the priority date claimed

- "T" later document published after the international filing date or priority date and not in conflict with the application but cited to understand the principle or theory underlying the invention
- "X" document of particular relevance; the claimed invention cannot be considered novel or cannot be considered to involve an inventive step when the document is taken alone
- "Y" document of particular relevance; the claimed invention cannot be considered to involve an inventive step when the document is combined with one or more other such documents, such combination being obvious to a person skilled in the art
- "&" document member of the same patent family

Date of the actual completion of the international search

13 June 2014

Date of mailing of the international search report

26/06/2014

Name and mailing address of the ISA/  
 European Patent Office, P.B. 5818 Patentlaan 2  
 NL - 2280 HV Rijswijk  
 Tel. (+31-70) 340-2040,  
 Fax: (+31-70) 340-3016

Authorized officer  
  
 Schiffer, Andrea

# INTERNATIONAL SEARCH REPORT

Information on patent family members

International application No PCT/US2014/021979
---------------------------------------------------

Patent document cited in search report		Publication date	Patent family member(s)	Publication date
WO 2008109478	A2	12-09-2008	AU 2008223016 A1 CA 2676079 A1 CN 101617494 A EP 2130320 A2 JP 5043960 B2 JP 2010520715 A KR 20090115977 A US 2008212709 A1 US 2012155565 A1 US 2013215991 A1 WO 2008109478 A2	12-09-2008 12-09-2008 30-12-2009 09-12-2009 10-10-2012 10-06-2010 10-11-2009 04-09-2008 21-06-2012 22-08-2013 12-09-2008
-----				
WO 2008151251	A1	11-12-2008	EP 2156555 A1 US 2010215118 A1 WO 2008151251 A1	24-02-2010 26-08-2010 11-12-2008
-----				