



US 20220316467A1

(19) **United States**

(12) **Patent Application Publication**  
**OGATA**

(10) **Pub. No.: US 2022/0316467 A1**

(43) **Pub. Date: Oct. 6, 2022**

(54) **PIEZOELECTRIC PUMP AND PUMP UNIT**

**Publication Classification**

(71) Applicant: **KYOCERA Corporation**, Kyoto-shi,  
Kyoto (JP)  
(72) Inventor: **Kazuhiro OGATA**, Kirishima-shi (JP)  
(73) Assignee: **KYOCERA Corporation**, Kyoto-shi,  
Kyoto (JP)

(51) **Int. Cl.**  
**F04B 43/04** (2006.01)  
**F04B 53/16** (2006.01)  
(52) **U.S. Cl.**  
CPC ..... **F04B 43/046** (2013.01); **F04B 53/16**  
(2013.01)

(21) Appl. No.: **17/641,564**

(57) **ABSTRACT**

(22) PCT Filed: **Sep. 7, 2020**

(86) PCT No.: **PCT/JP2020/033802**

§ 371 (c)(1),  
(2) Date: **Mar. 9, 2022**

A pump unit includes a piezoelectric pump and a housing accommodating the piezoelectric pump. The piezoelectric pump includes a piezoelectric device having a through-hole, a first elastic plate covering an end of the through-hole, and a second elastic plate covering another end of the through-hole. The first elastic plate has a communication hole communicating with the through-hole of the piezoelectric device.

(30) **Foreign Application Priority Data**

Sep. 11, 2019 (JP) ..... 2019-165693

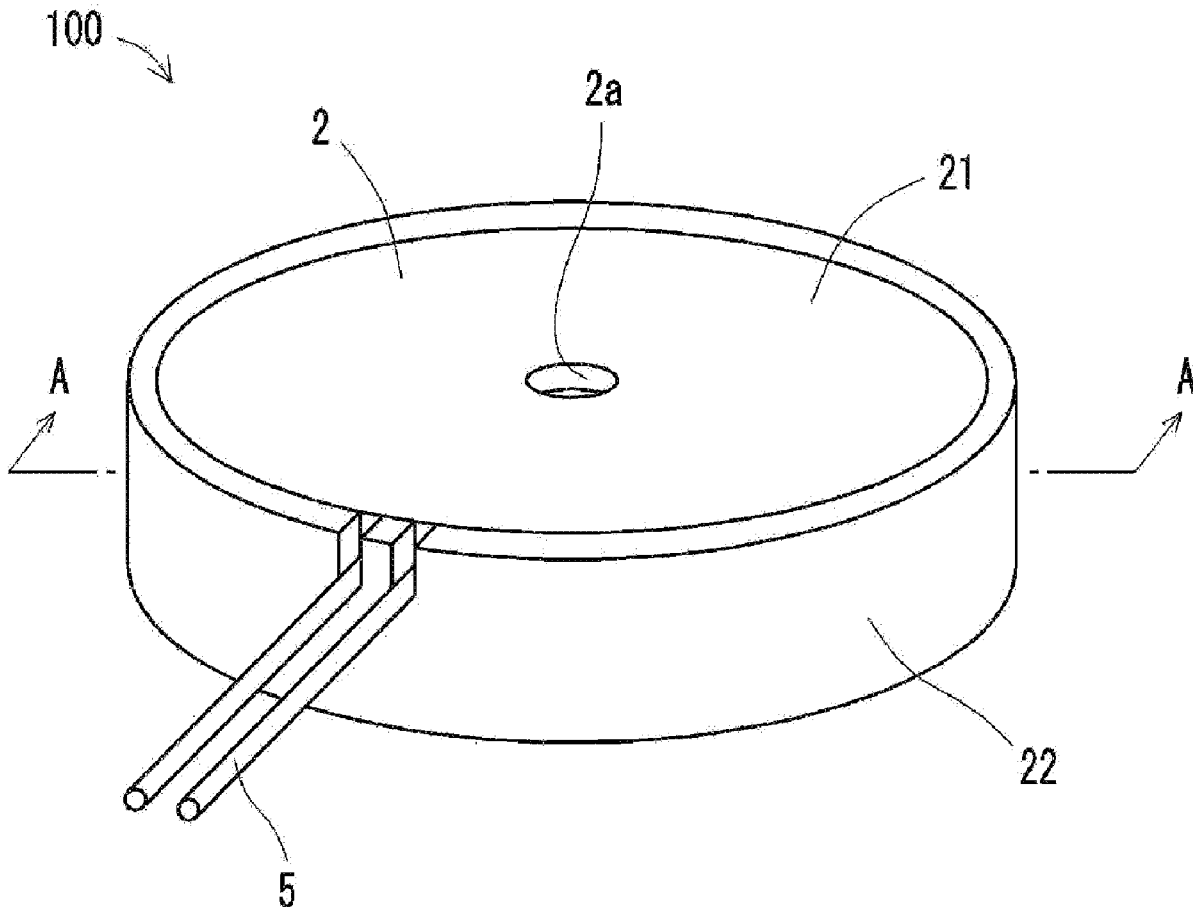

FIG. 1

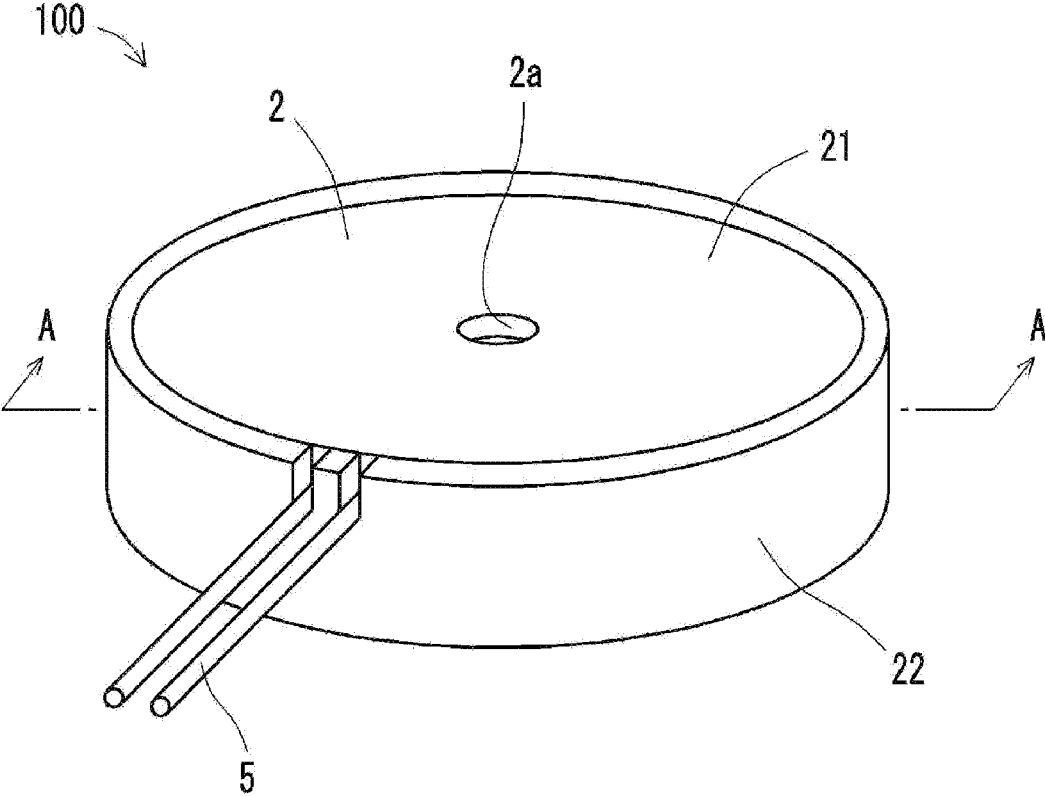

FIG. 2

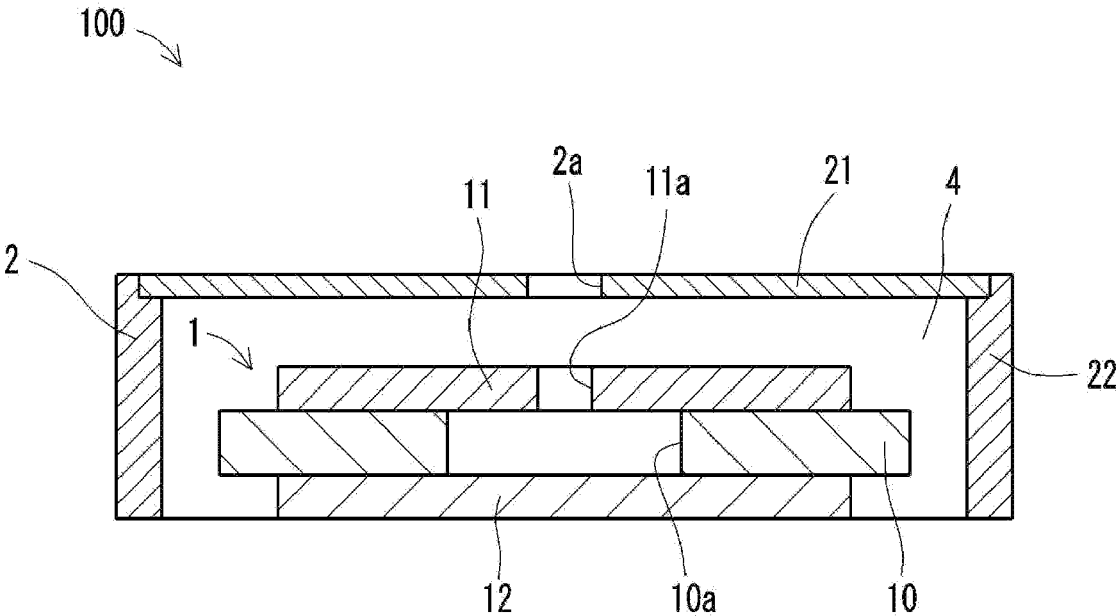

FIG. 3

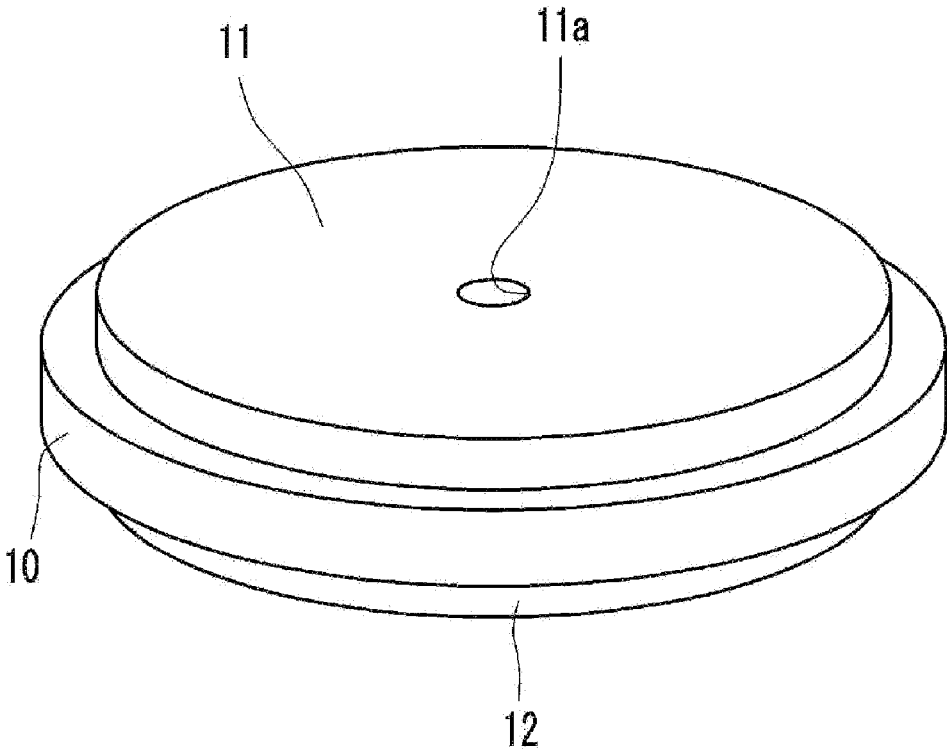

FIG. 4A

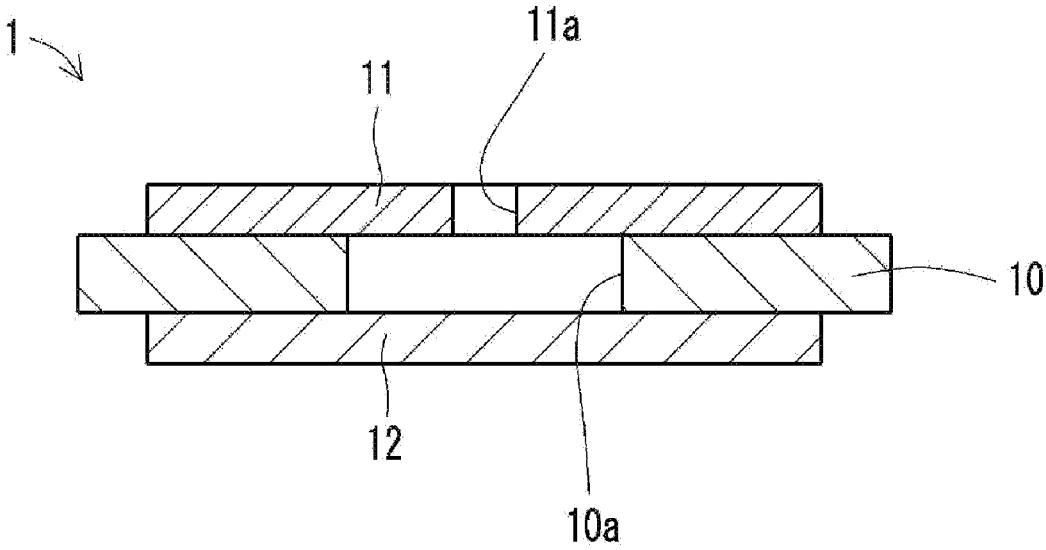

FIG. 4B

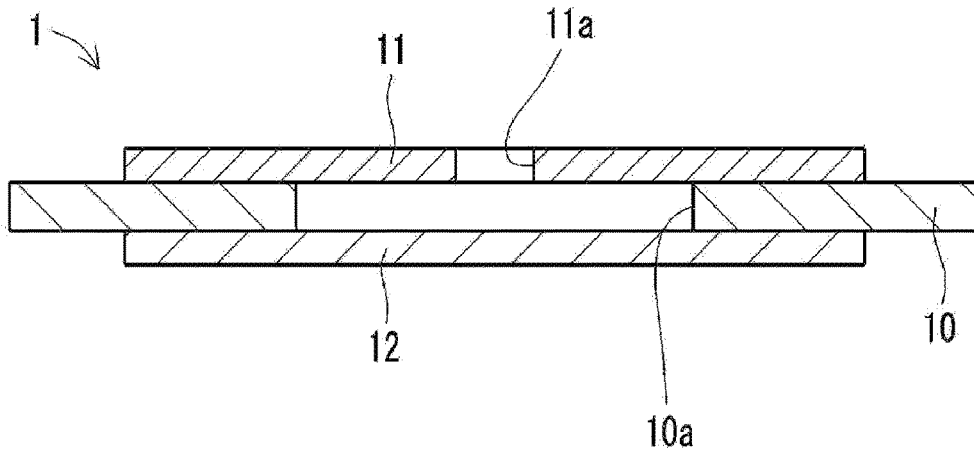

FIG. 5A

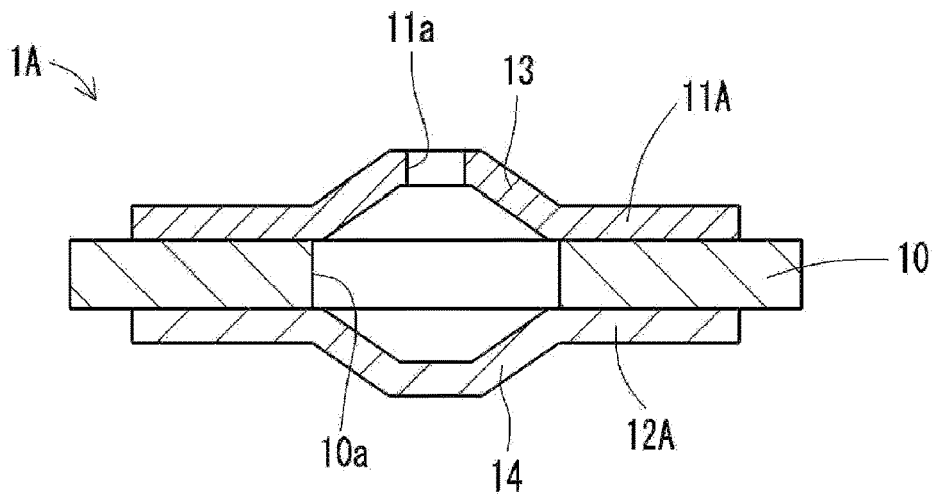

FIG. 5B

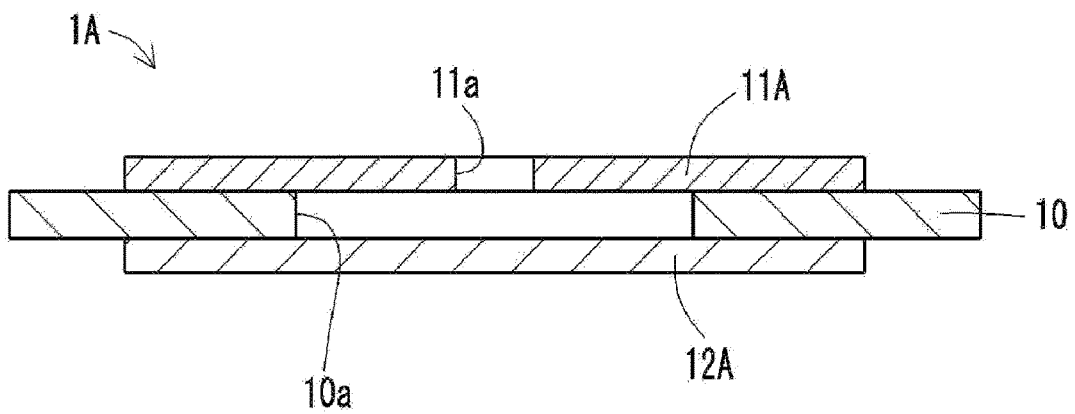

FIG. 6A

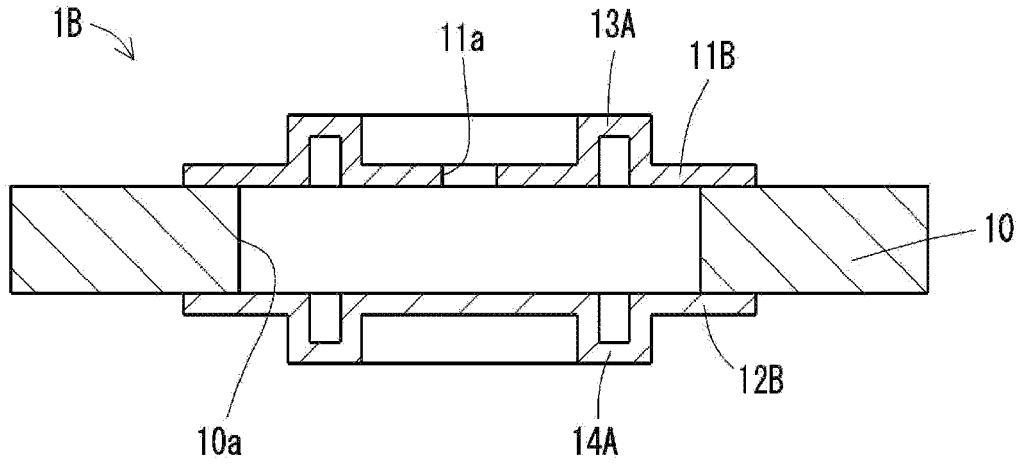

FIG. 6B

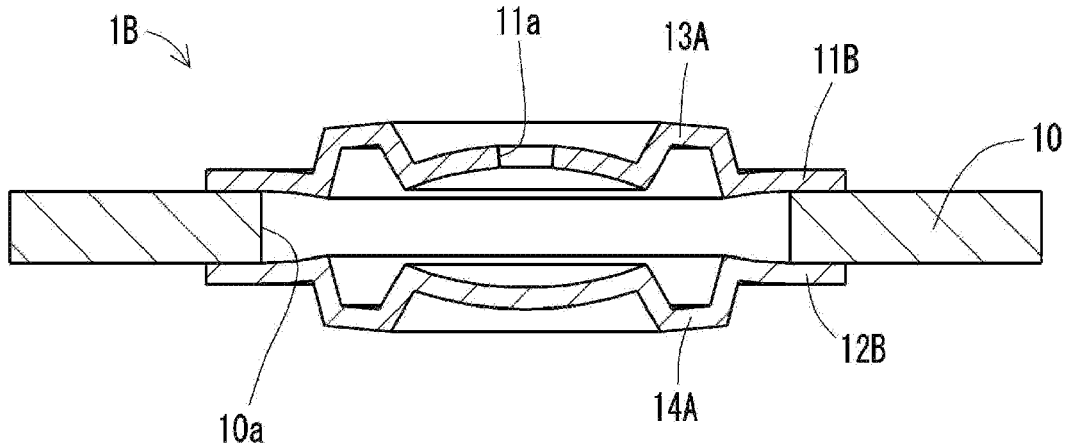

FIG. 6C

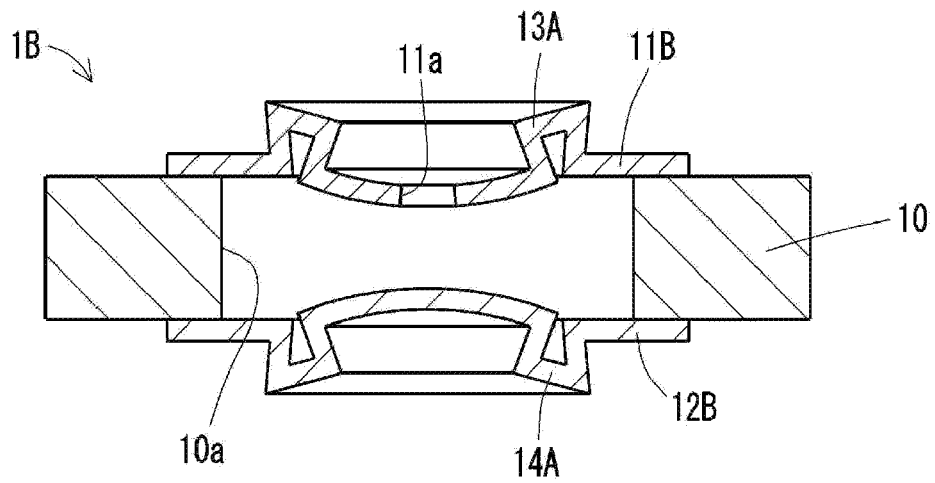

FIG. 7A

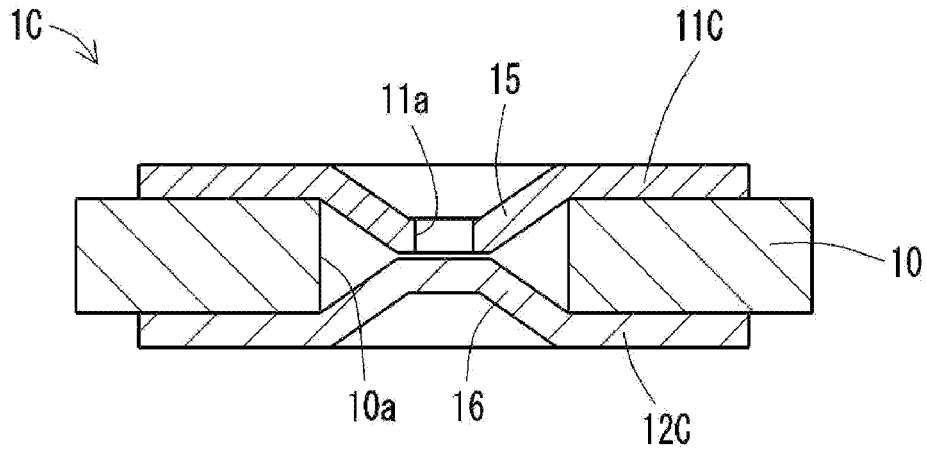

FIG. 7B

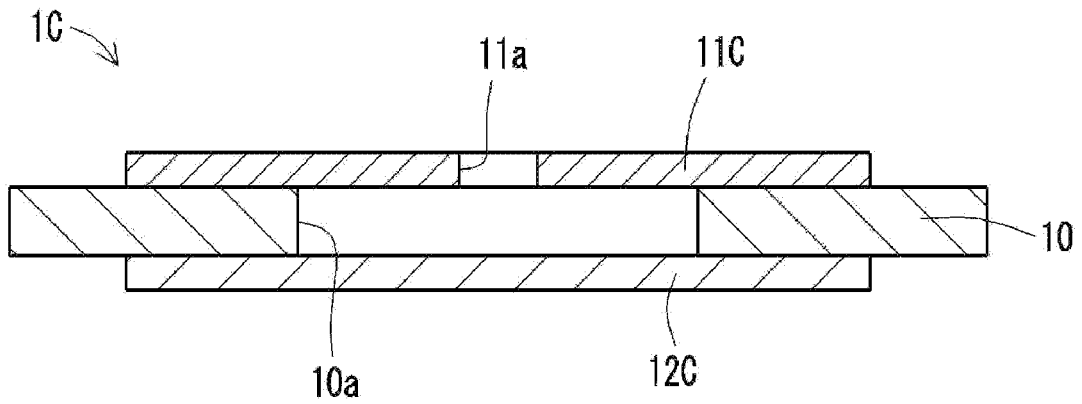

FIG. 8A

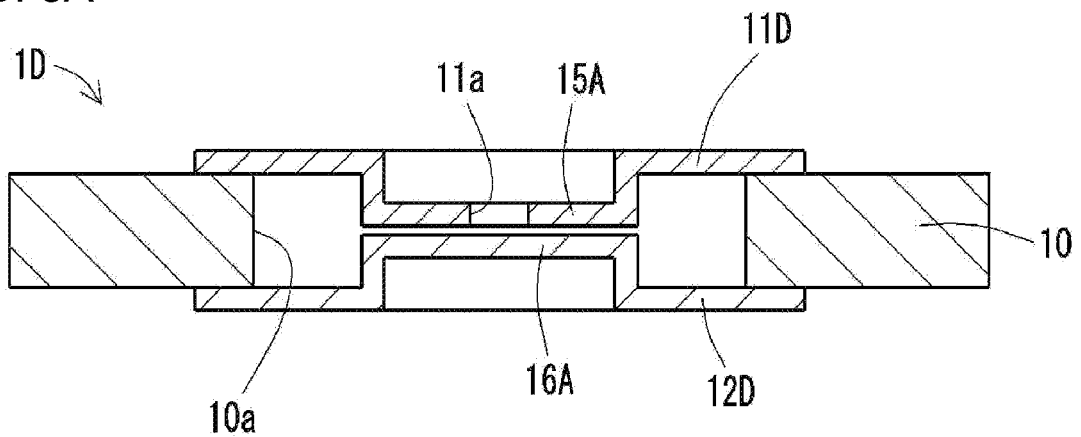

FIG. 8B

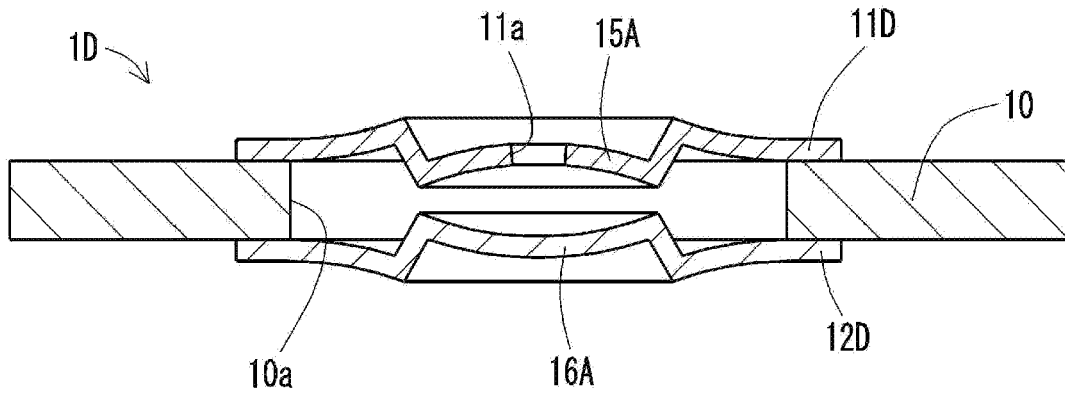

FIG. 8C

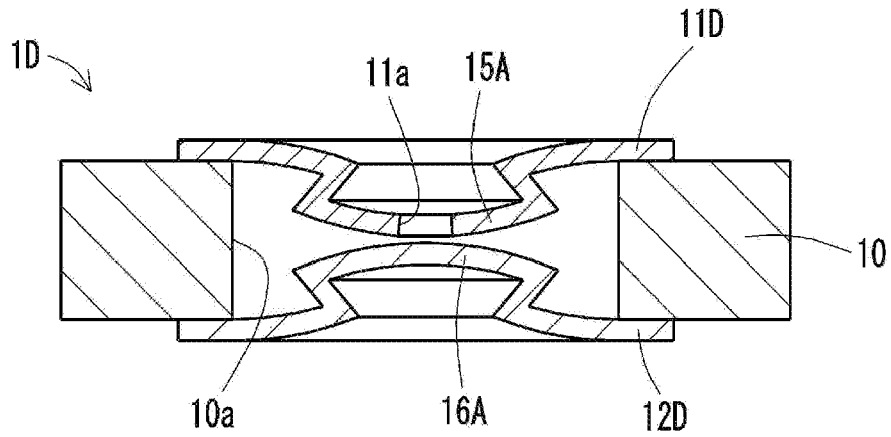

FIG. 9A

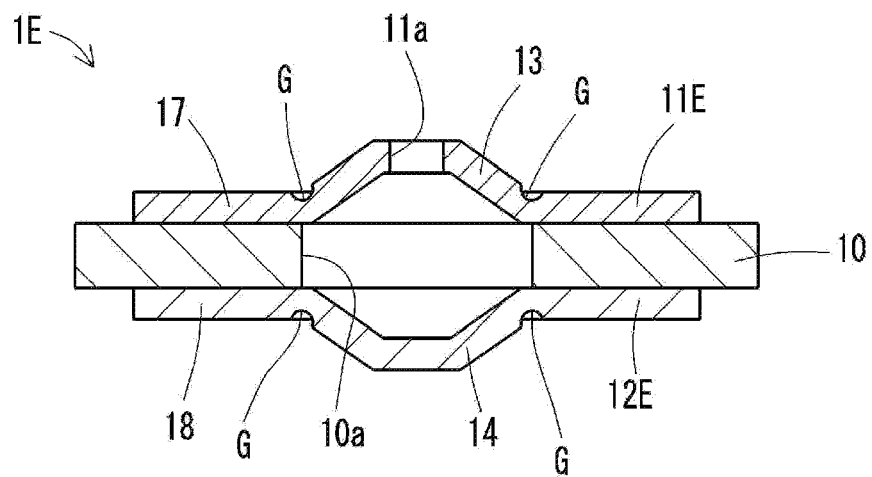

FIG. 9B

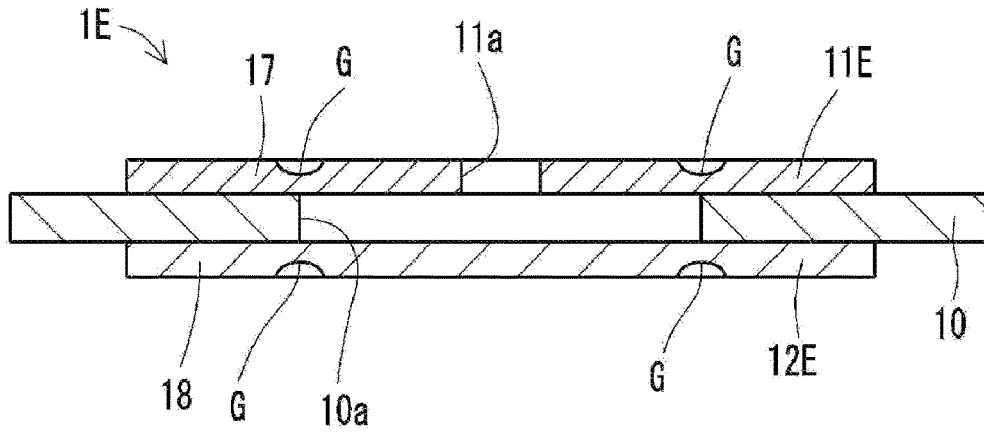

FIG. 10A

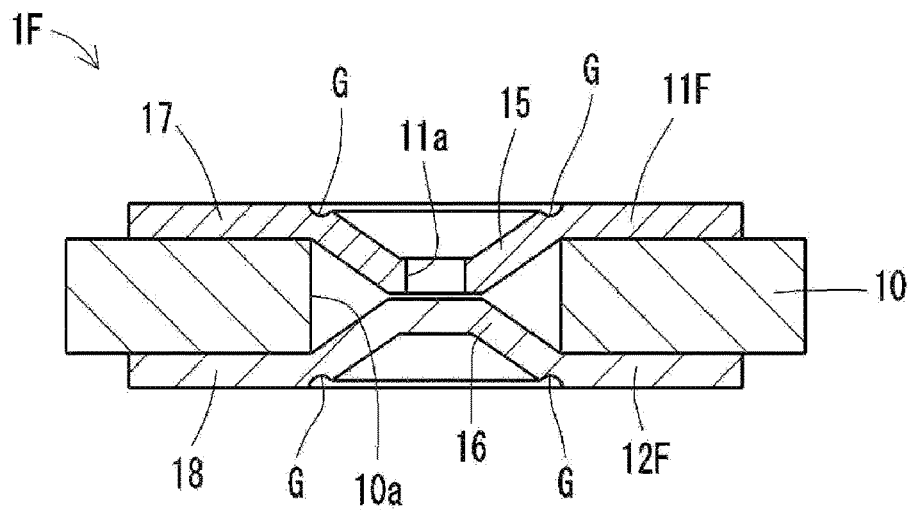
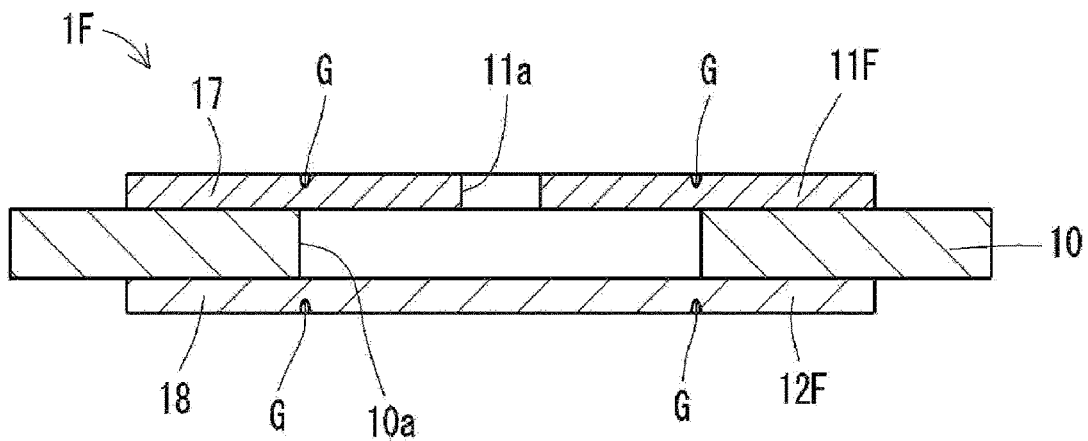

FIG. 10B



## PIEZOELECTRIC PUMP AND PUMP UNIT

### FIELD

[0001] The present disclosure relates to a piezoelectric pump and a pump unit.

### BACKGROUND

[0002] In a known structure such as a piezoelectric micro blower described in Patent Literature 1, a piezoelectric device attached to a diaphragm is driven to vibrate the diaphragm.

[0003] The piezoelectric device vibrates the diaphragm with a known technique. This pump thus has the same characteristics as a diaphragm pump. Further, the pump may operate unstably when a piezoelectric vibrating plate including the piezoelectric device and the diaphragm vibrates out of synchronization with the entire pump chamber. Piezoelectric pumps are to have improved pump characteristics such as operational stability.

### CITATION LIST

#### Patent Literature

[0004] Patent Literature 1: WO 2008/069266

### BRIEF SUMMARY

[0005] A piezoelectric pump according to an aspect of the present disclosure includes a piezoelectric device having a through-hole, a first elastic plate covering an end of the through-hole and having a communication hole communicating with the through-hole, and a second elastic plate covering another end of the through-hole.

[0006] A pump unit according to an aspect of the present disclosure includes the piezoelectric pump described above, and a housing accommodating the piezoelectric pump. The housing includes an outlet facing the communication hole in the first elastic plate.

### BRIEF DESCRIPTION OF DRAWINGS

[0007] The objects, features, and advantages of the present invention will become more apparent from the following detailed description and the drawings.

[0008] FIG. 1 is a schematic perspective view of a pump unit.

[0009] FIG. 2 is a cross-sectional view taken along line A-A in FIG. 1.

[0010] FIG. 3 is a schematic perspective view of a piezoelectric pump.

[0011] FIG. 4A is a schematic cross-sectional view of a piezoelectric pump according to a first embodiment in an operating state.

[0012] FIG. 4B is a schematic cross-sectional view of the piezoelectric pump according to the first embodiment in an operating state.

[0013] FIG. 5A is a schematic cross-sectional view of a piezoelectric pump according to a second embodiment in an operating state.

[0014] FIG. 5B is a schematic cross-sectional view of the piezoelectric pump according to the second embodiment in an operating state.

[0015] FIG. 6A is a schematic cross-sectional view of a piezoelectric pump according to a third embodiment in an operating state.

[0016] FIG. 6B is a schematic cross-sectional view of the piezoelectric pump according to the third embodiment in an operating state.

[0017] FIG. 6C is a schematic cross-sectional view of the piezoelectric pump according to the third embodiment in an operating state.

[0018] FIG. 7A is a schematic cross-sectional view of a piezoelectric pump according to a fourth embodiment in an operating state.

[0019] FIG. 7B is a schematic cross-sectional view of the piezoelectric pump according to the fourth embodiment in an operating state.

[0020] FIG. 8A is a schematic cross-sectional view of a piezoelectric pump according to a fifth embodiment in an operating state.

[0021] FIG. 8B is a schematic cross-sectional view of the piezoelectric pump according to the fifth embodiment in an operating state.

[0022] FIG. 8C is a schematic cross-sectional view of the piezoelectric pump according to the fifth embodiment in an operating state.

[0023] FIG. 9A is a schematic cross-sectional view of a piezoelectric pump according to a sixth embodiment in an operating state.

[0024] FIG. 9B is a schematic cross-sectional view of the piezoelectric pump according to the sixth embodiment in an operating state.

[0025] FIG. 10A is a schematic cross-sectional view of a piezoelectric pump according to a seventh embodiment in an operating state.

[0026] FIG. 10B is a schematic cross-sectional view of the piezoelectric pump according to the seventh embodiment in an operating state.

### DETAILED DESCRIPTION

[0027] Example piezoelectric pumps will now be described in detail with reference to the accompanying drawings. The embodiments described below do not limit the present invention. FIG. 1 is a schematic perspective view of a pump unit, and FIG. 2 is a cross-sectional view taken along line A-A in FIG. 1. FIG. 3 is a schematic perspective view of a piezoelectric pump. FIGS. 4A and 4B each are a schematic cross-sectional view of a piezoelectric pump according to a first embodiment in an operating state.

[0028] A pump unit 100 includes a piezoelectric pump 1 and a housing 2 accommodating the piezoelectric pump 1. The piezoelectric pump 1 includes a piezoelectric device 10 having a through-hole 10a, a first elastic plate 11 covering one end of the through-hole 10a, and a second elastic plate 12 covering the other end of the through-hole 10a. The first elastic plate 11 includes a communication hole 11a communicating with the through-hole 10a of the piezoelectric device 10.

[0029] The piezoelectric device 10 includes, for example, a piezoelectric member having the through-hole 10a and surface electrodes mounted on a pair of main surfaces of the piezoelectric member opposite to each other. The piezoelectric member included in the piezoelectric device 10 may be formed from piezoelectric ceramics based on lead zirconate titanate, barium titanate, or potassium sodium niobate or a piezoelectric single crystal such as quartz or lithium tanta-

late. The surface electrodes included in the piezoelectric device 10 may be formed from, for example, silver, nickel, copper, or a silver-palladium alloy.

[0030] The piezoelectric device 10 may have any shape that has the through-hole 10a. The piezoelectric device 10 may be a plate or a column. The piezoelectric device 10 being a plate may be circular or polygonal. The piezoelectric device 10 being columnar may be circular or polygonal. The through-hole 10a may be at any position. For the plate-like or columnar piezoelectric device 10, the through-hole 10a is coaxial with the piezoelectric member. In the present embodiment, the piezoelectric device 10 is a circular plate and the through-hole 10a is coaxial with the piezoelectric member.

[0031] As shown in FIG. 1, the piezoelectric device 10 is connected with an external circuit with, for example, a wiring member 5. The piezoelectric pump 1 can be driven by controlling an applied voltage and vibrating the piezoelectric device 10. The piezoelectric device 10 may have the surface electrodes on the pair of surfaces of the piezoelectric member opposite to each other mounted in the manner described below.

[0032] The piezoelectric device 10 may be separately excited and may include surface electrodes (a pair of surface electrodes) that are separately mounted on the respective two surfaces to spread in the planar direction on the surfaces.

[0033] The piezoelectric device 10 may also be self-excited and may include, on one surface, a surface electrode including a main surface electrode and a sub-surface electrode separated from the main surface electrode. This structure can drive, for example, multiple piezoelectric pumps 1 with optimum frequencies and thus can reduce differences in the fluid flow rate between the individual piezoelectric pumps 1. This structure also reduces changes in the fluid flow rate resulting from varying environmental temperatures of, for example,  $-20$  to  $+80^{\circ}$  C.

[0034] The first elastic plate 11 is formed from an elastically deformable material and may have any shape that covers one end of the through-hole 10a. In the same manner, the second elastic plate 12 is formed from an elastically deformable material and may have any shape that covers the other end of the through-hole 10a. The first elastic plate 11 includes the communication hole 11a communicating with the through-hole 10a of the piezoelectric device 10.

[0035] The first elastic plate 11 and the second elastic plate 12 elastically deform to follow deformation (vibration) of the piezoelectric device 10. For example, when the piezoelectric device 10 deforms and extends in the radial direction as shown schematically in FIGS. 4A and 4B, the first elastic plate 11 and the second elastic plate 12 may also deform elastically to extend in the radial direction. When the piezoelectric device 10 deforms and shrinks in the radial direction, the first elastic plate 11 and the second elastic plate 12 may also deform elastically to shrink in the radial direction. More specifically, when the piezoelectric device 10 deforms and shrinks in the radial direction, the piezoelectric device 10 may deform and extend in the thickness direction. When the piezoelectric device 10 deforms and extends in the radial direction, the piezoelectric device 10 may deform and shrink in the thickness direction.

[0036] Upon receiving an applied voltage, the piezoelectric device 10 deforms and repeatedly changes between the states shown in FIGS. 4A and 4B. As the volume of an internal space defined by the piezoelectric device 10, the first

elastic plate 11, and the second elastic plate 12 changes, the fluid in the internal space is repeatedly drawn in and out through the communication hole 11a to function as pump.

[0037] In the example shown in FIGS. 4A and 4B, the piezoelectric device 10 in the state shown in FIG. 4B (second state) deforms more outward in the radial direction to have a larger volume in the internal space than in the state shown in FIG. 4A (first state). The deformation from the first state to the second state causes external fluid to be drawn in. The deformation from the second state to the first state reduces the volume of the internal space and causes the fluid inside to be out.

[0038] The first elastic plate 11 and the second elastic plate 12 may be formed from a metal material such as stainless steel (SUS), brass, or alloy 42 or a resin material such as polybutylene terephthalate (PBT) or a liquid crystal polymer. The use of alloy 42 reduces the difference in thermal expansion from the piezoelectric device 10, effectively reducing changes in the fluid flow rate resulting from changes in environmental temperature.

[0039] The first elastic plate 11 and the second elastic plate 12 may have any thickness that allows the plates to deform to follow the deformation of the piezoelectric device 10. The first elastic plate 11 and the second elastic plate may have a thickness of 50 to 500  $\mu$ m. The first elastic plate 11 may have one communication hole 11a as in the present embodiment or multiple communication holes 11a.

[0040] The piezoelectric pump 1 in one or more embodiments of the present disclosure repeatedly draws fluid in and out in accordance with changes in the volume of the through-hole 10a as the piezoelectric device 10 deforms. The characteristics of the piezoelectric device 10 directly affect the operation of the piezoelectric pump 1, allowing the piezoelectric pump 1 to operate stably. Further, controlling the changes in the volume allows precise control of the flow rate. In this manner, the characteristics of the piezoelectric pump 1 can be improved.

[0041] The housing 2 accommodates the piezoelectric pump 1 described above and has an outlet 2a facing the communication hole 11a in the first elastic plate 11. The housing 2 in the present embodiment includes a top plate 21 facing the first elastic plate 11 and a cylindrical frame 22 supporting the top plate 21 and surrounding the piezoelectric pump 1. The housing 2 in the present embodiment covers and accommodates the piezoelectric pump 1 placed on, for example, a platform. The housing 2 may additionally include a bottom plate to entirely cover and accommodate the piezoelectric pump 1.

[0042] The gap between the accommodated piezoelectric pump 1 and the housing 2 in the internal space of the housing 2 serves as a fluid channel 4, through which fluid flows in and out of the housing 2 with the piezoelectric pump 1. When the piezoelectric pump 1 is driven and deforms from the first state to the second state as described above, the fluid in the fluid channel 4 is drawn in through the communication hole 11a. When the piezoelectric pump 1 deforms from the second state to the first state, the fluid drawn in is discharged through the communication hole 11a. At the same time, the fluid is discharged out of the housing 2 through the outlet 2a facing the communication hole 11a.

[0043] The pump unit 100 may discharge any fluid. Fluid to be discharged may be, for example, air or a functional fluid containing an aromatic agent, a disinfectant agent, or an antibacterial agent. The pump unit 100 is, for example,

installed inside an electronic device to cool electronic components, or may be installed in a vehicle such as an automobile, in a house, or in a living space such as in a theater or other entertainment facilities to discharge a functional fluid.

**[0044]** The housing **2** may be formed from a metal material such as stainless steel (SUS), brass, or alloy **42** or a resin material such as PBT or a liquid crystal polymer. The frame **22** is bonded to the outer periphery of the top plate **21** and supports the top plate **21**. The frame **22** has a step on the inner surface in the example shown in FIG. **2**. In some embodiments, the frame **22** may have an axially constant thickness and support the top plate **21** on its end face, or may have, on the inner surface, a grooved portion engaged with the periphery of the top plate **21** to support the top plate **21**. Although the wiring member **5** extends outside through insertion ports in the frame **22** in the example shown in FIG. **1**, the wiring member **5** may extend outside in any other manner.

**[0045]** FIGS. **5A** and **5B** each are a schematic cross-sectional view of a piezoelectric pump according to a second embodiment in an operating state. A piezoelectric pump **1A** in the present embodiment includes the same components as the piezoelectric pump **1** in the first embodiment except a first elastic plate **11A** and a second elastic plate **12A**. The components that are the same as those of the piezoelectric pump **1** in the first embodiment are given the same reference numerals and will not be described in detail. In the present embodiment, the first elastic plate **11A** includes a protrusion **13**, and the second elastic plate **12A** includes a protrusion **14**. The protrusions **13** and **14** protrude outward in the axial direction of the through-hole **10a** of the piezoelectric device **10**. Each of the protrusions **13** and **14** in the present embodiment has a shape with a peak (highest point) at the center of the first elastic plate **11A** or the second elastic plate **12A**, which may be, for example, a cone, a truncated cone, or a hemisphere.

**[0046]** The piezoelectric pump **1A** in the second embodiment operates in the same manner as the piezoelectric pump **1** in the first embodiment. Upon receiving an applied voltage, the piezoelectric device **10** deforms and repeatedly changes between a first state shown in FIG. **5A** and a second state shown in FIG. **5B**. In the first state, the internal space defined by the piezoelectric device **10**, the first elastic plate **11A**, and the second elastic plate **12A** has a larger volume due to the protrusions **13** and **14** than in the first embodiment. In the second embodiment, the volume of the internal space changes between the first state and the second state more largely than in the first embodiment. This structure can increase the fluid flow rate while precisely controlling the flow rate.

**[0047]** The first elastic plate **11A** including the protrusion **13** and the second elastic plate **12A** including the protrusion **14** with the shape as described in the present embodiment may be formed from a metal material with, for example, a known processing method such as pressing. For a resin material, a known processing method such as molding may be used.

**[0048]** FIGS. **6A** to **6C** each are a schematic cross-sectional view of a piezoelectric pump according to a third embodiment in an operating state. A piezoelectric pump **1B** in the present embodiment includes the same components as the piezoelectric pump **1A** in the second embodiment except a first elastic plate **11B** and a second elastic plate **12B**. The

components that are the same as those of the piezoelectric pump **1A** in the second embodiment are given the same reference numerals and will not be described in detail. In the present embodiment, the first elastic plate **11B** includes a protrusion **13A** and the second elastic plate **12B** includes a protrusion **14A**. The protrusions **13A** and **14A** are circular and concentric with the first elastic plate **11B** and the second elastic plate **12B**.

**[0049]** The piezoelectric pump **1B** in the third embodiment operates in the same manner as the piezoelectric pump **1A** in the second embodiment. Upon receiving an applied voltage, the piezoelectric device **10** deforms to a first state shown in FIG. **6A**, a second state shown in FIG. **6B**, or a third state shown in FIG. **6C**. In the second state, the piezoelectric device **10** deforms and extends more outward in the radial direction than in the first state. In the third state, the piezoelectric device **10** deforms and shrinks more inward in the radial direction than in the first state. The state of the piezoelectric device **10** changes to change the volume of the internal space in response to a change in the voltage applied to the piezoelectric device **10**. The piezoelectric pump **1B** repeatedly draws fluid in and out of the internal space through the communication hole **11a** to function as a pump. Although the piezoelectric device **10** can change between the three states in the present embodiment, the piezoelectric device **10** in operation may switch between two of the states repeatedly, or may switch between the three states repeatedly. The volume of the internal space differs depending on the state of the piezoelectric device **10**. The state is thus selected from the three states to control the fluid flow rate.

**[0050]** The first elastic plate **11B** including the protrusion **13A** and the second elastic plate **12B** including the protrusion **14A** with the shape as described in the present embodiment may be formed from a metal material with, for example, a known processing method such as pressing. For a resin material, a known processing method such as molding may be used.

**[0051]** FIGS. **7A** and **7B** each are a schematic cross-sectional view of a piezoelectric pump according to a fourth embodiment in an operating state. A piezoelectric pump **1C** in the present embodiment includes the same components as the piezoelectric pump **1** in the first embodiment except a first elastic plate **11C** and a second elastic plate **12C**. The components that are the same as those of the piezoelectric pump **1** in the first embodiment are given the same reference numerals and will not be described in detail. In the present embodiment, the first elastic plate **11C** includes a recess **15**, and the second elastic plate **12C** includes a recess **16**. The recesses **15** and **16** are inward in the axial direction of the through-hole **10a** of the piezoelectric device **10**. Each of the recesses **15** and **16** in the present embodiment may have a shape with a peak (lowest point) at the center of the first elastic plate **11C** or the second elastic plate **12C**, which may be, for example, a cone, a truncated cone, or a hemisphere.

**[0052]** The piezoelectric pump **1C** in the fourth embodiment operates in the same manner as the piezoelectric pump **1** in the first embodiment. Upon receiving an applied voltage, the piezoelectric device **10** repeatedly deforms between a first state shown in FIG. **7A** and a second state shown in FIG. **7B**. In the first state, the volume of the internal space defined by the piezoelectric device **10**, the first elastic plate **11C**, and the second elastic plate **12C** is smaller than in the first embodiment due to the recesses **15** and **16** inward in the through-hole **10a**. In the fourth embodiment, the volume of

the internal space changes between the first state and the second state more largely than in the first embodiment. This structure can increase the fluid flow rate while precisely controlling the flow rate.

[0053] The first elastic plate 11C including the recess 15 and the second elastic plate 12C including the recess 16 may be formed from a metal material with, for example, a known processing method such as pressing. For a resin material, a known processing method such as molding may be used.

[0054] FIGS. 8A to 8C each are a schematic cross-sectional view of a piezoelectric pump according to a fifth embodiment in an operating state. A piezoelectric pump 1D in the present embodiment includes the same components as the piezoelectric pump 1C in the fourth embodiment except a first elastic plate 11D and a second elastic plate 12D. The components that are the same as those of the piezoelectric pump 1C in the fourth embodiment are given the same reference numerals and will not be described in detail. In the present embodiment, the first elastic plate 11D includes a recess 15A, and the second elastic plate 12D includes a recess 16A. The recesses 15A and 16A are cylindrical and coaxial with the first elastic plate 11D and the second elastic plate 12D.

[0055] The piezoelectric pump 1D in the fifth embodiment operates in the same manner as the piezoelectric pump 1C in the fourth embodiment. Upon receiving an applied voltage, the piezoelectric device 10 deforms to a first state shown in FIG. 8A, a second state shown in FIG. 8B, or a third state shown in FIG. 8C. In the second state, the piezoelectric device 10 deforms and extends more outward in the radial direction than in the first state. In the third state, the piezoelectric device 10 deforms and shrinks more inward in the radial direction than in the first state. The state of the piezoelectric device 10 changes to change the volume of the internal space in response to a change in the voltage applied to the piezoelectric device 10. The piezoelectric pump 1D repeatedly draws the fluid in and out of the internal space through the communication hole 11a to function as a pump. Although the piezoelectric device 10 can change between the three states as the piezoelectric pump 1B in the third embodiment, the piezoelectric device 10 in operation may switch between two of the states repeatedly, or may switch between the three states repeatedly. The volume of the internal space differs depending on the state of the piezoelectric device 10. The state is thus selected from the three states to control the fluid flow rate.

[0056] The first elastic plate 11D including the recess 15A and the second elastic plate 12D including the recess 16A with the shape as described in the present embodiment may be formed from a metal material with, for example, a known processing method such as pressing. For a resin material, a known processing method such as molding may be used.

[0057] FIGS. 9A and 9B each are a schematic cross-sectional view of a piezoelectric pump according to a sixth embodiment in an operating state. A piezoelectric pump 1E in the present embodiment includes the same components as the piezoelectric pump 1A in the second embodiment except a first elastic plate 11E and a second elastic plate 12E. The components that are the same as those of the piezoelectric pump 1A in the second embodiment are given the same reference numerals and will not be described in detail. In the present embodiment, the first elastic plate 11E includes the protrusion 13, a flat portion 17, and a groove G. The second elastic plate 12E includes the protrusion 14, a flat portion 18,

and a groove G. The protrusions 13 and 14 protrude outward in the axial direction of the through-hole 10a of the piezoelectric device 10. The flat portions 17 and 18 surround the protrusions 13 and 14. The grooves G are located between the protrusion 13 and the flat portion 17 and between the protrusion 14 and the flat portion 18.

[0058] The piezoelectric pump 1E in the sixth embodiment operates in the same manner as the piezoelectric pump 1A in the second embodiment. Upon receiving an applied voltage, the piezoelectric device 10 repeatedly deforms between a first state shown in FIG. 9A and a second state shown in FIG. 9B. In the sixth embodiment, the volume of the internal space changes between the first state and the second state in the same manner as in the second embodiment. The first elastic plate 11E and the second elastic plate 12E including the grooves G may deform with a smaller force than the structure in the second embodiment with no grooves G. In other words, a lower voltage applied to the piezoelectric device 10 than in the second embodiment can deform the first elastic plate 11E and the second elastic plate 12E in the same manner as in the second embodiment to control the fluid flow rate in the same manner.

[0059] The first elastic plate 11E and the second elastic plate 12E including the grooves G may be formed from a metal material with, for example, a known processing method such as pressing. For a resin material, a known processing method such as molding may be used.

[0060] FIGS. 10A and 10B each are a schematic cross-sectional view of a piezoelectric pump according to a seventh embodiment in an operating state. A piezoelectric pump 1F in the present embodiment includes the same components as the piezoelectric pump 1C in the fourth embodiment except a first elastic plate 11F and a second elastic plate 12F. The components that are the same as those of the piezoelectric pump 1C in the fourth embodiment are given the same reference numerals and will not be described in detail. In the present embodiment, the first elastic plate 11F includes the recess 15, a flat portion 17, and a groove G. The second elastic plate 12F includes the recess 16, a flat portion 18, and a groove G. The recesses 15 and 16 are inward in the axial direction of the through-hole 10a of the piezoelectric device 10. The flat portions 17 and 18 surround the recesses 15 and 16. The grooves G are located between the recess 15 and the flat portion 17 and between the recess 16 and the flat portion 18.

[0061] The piezoelectric pump 1F in the seventh embodiment operates in the same manner as the piezoelectric pump 1C in the fourth embodiment. Upon receiving an applied voltage, the piezoelectric device 10 repeatedly deforms between a first state shown in FIG. 10A and a second state shown in FIG. 10B. In the seventh embodiment, the volume of the internal space changes between the first state and the second state in the same manner as in the fourth embodiment. The first elastic plate 11F and the second elastic plate 12F including the grooves G may deform with a smaller force than the structure in the fourth embodiment with no grooves G. In other words, a lower voltage applied to the piezoelectric device 10 than in the fourth embodiment can deform the first elastic plate 11F and the second elastic plate 12F in the same manner as in the fourth embodiment to control the fluid flow rate in the same manner.

[0062] The first elastic plate 11F and the second elastic plate 12F including the grooves G may be formed from a metal material with, for example, a known processing

method such as pressing. For a resin material, a known processing method such as molding may be used.

[0063] An example method for manufacturing a piezoelectric pump will now be described.

[0064] Materials for forming the piezoelectric device 10, such as lead zirconate titanate, are mixed with, for example, a ball mill. The resultant mixture is then calcinated at 700 to 1200° C. The calcinated material is milled with, for example, a ball mill, mixed with a forming binder, and then granulated with a spray dryer.

[0065] The resultant granules are pressed with a mold having an axis pin around the center to form a compact with a through-hole. The compact is degreased and then fired to form a piezoelectric member. The resultant piezoelectric member is processed with, for example, lapping to an intended shape. After a paste for surface electrodes is printed, the piezoelectric member is baked at 500 to 800° C. to form surface electrodes. A voltage of about 3 kV/mm is then applied to form the piezoelectric device 10 with intended piezoelectric characteristics.

[0066] Subsequently, plates of alloy 42 are, for example, pressed to an intended shape to form the first elastic plate 11 and the second elastic plate 12. For example, a thermosetting epoxy adhesive is then printed onto the first elastic plate 11 and the second elastic plate 12. The printed portion of the adhesive is then heated at 80 to 200° C. while being in contact with the piezoelectric device 10. This bonds the first elastic plate 11 and the second elastic plate 12 to the piezoelectric device 10.

[0067] The wiring member 5 is prepared for inputting an external electric signal into the piezoelectric device 10, such as a lead wire with its side surface coated with resin. The wiring member 5 is electrically and mechanically bonded to the surface electrodes of the piezoelectric device 10 with a bond material such as solder. This completes the piezoelectric pump 1.

[0068] In another embodiment, the housing 2 formed from alloy 42 may be prepared. The piezoelectric pump 1 may be accommodated in the housing 2. The piezoelectric pump 1 and the housing 2 may then be bonded with each other as appropriate. This completes the pump unit 100.

[0069] The piezoelectric pump according to embodiments of the present disclosure repeatedly draws fluid in and out in accordance with changes in the volume of the through-hole as the piezoelectric device deforms. The characteristics of the piezoelectric device directly affect the operation of the piezoelectric pump, allowing the piezoelectric pump to operate stably. Further, the flow rate can be controlled precisely by controlling the changes in the volume. In other words, the characteristics of the piezoelectric pump may be improved.

[0070] The pump unit according to embodiments of the present disclosure includes any of the piezoelectric pumps described above, and may have improved characteristics.

[0071] The present invention may be embodied in various forms without departing from the spirit or the main features of the present invention. The embodiments described above are thus merely illustrative in all respects. The scope of the present invention is defined not by the description given above but by the claims. Any modifications and alterations contained in the claims fall within the scope of the present invention.

#### REFERENCE SIGNS LIST

- [0072] 1 piezoelectric pump
  - [0073] 1A piezoelectric pump
  - [0074] 1B piezoelectric pump
  - [0075] 1C piezoelectric pump
  - [0076] 1D piezoelectric pump
  - [0077] 1E piezoelectric pump
  - [0078] 1F piezoelectric pump
  - [0079] 2 housing
  - [0080] 2a outlet
  - [0081] 4 fluid channel
  - [0082] 5 wiring member
  - [0083] 10 piezoelectric device
  - [0084] 10a through-hole
  - [0085] 11 first elastic plate
  - [0086] 11A first elastic plate
  - [0087] 11B first elastic plate
  - [0088] 11C first elastic plate
  - [0089] 11D first elastic plate
  - [0090] 11E first elastic plate
  - [0091] 11F first elastic plate
  - [0092] 11a communication hole
  - [0093] 12 second elastic plate
  - [0094] 12A second elastic plate
  - [0095] 12B second elastic plate
  - [0096] 12C second elastic plate
  - [0097] 12D second elastic plate
  - [0098] 12E second elastic plate
  - [0099] 12F second elastic plate
  - [0100] 13 protrusion
  - [0101] 13A protrusion
  - [0102] 14 protrusion
  - [0103] 14A protrusion
  - [0104] 15 recess
  - [0105] 15A recess
  - [0106] 16 recess
  - [0107] 16A recess
  - [0108] 17 flat portion
  - [0109] 18 flat portion
  - [0110] 21 top plate
  - [0111] 22 frame
  - [0112] 100 pump unit
  - [0113] G groove
1. A piezoelectric pump comprising:
    - a piezoelectric device having a through-hole;
    - a first elastic plate covering an end of the through-hole and having a communication hole communicating with the through-hole; and
    - a second elastic plate covering another end of the through-hole.
  2. The piezoelectric pump according to claim 1, wherein at least one of the first elastic plate or the second elastic plate includes a recess inward in an axial direction of the through-hole.
  3. The piezoelectric pump according to claim 2, wherein the at least one of the first elastic plate or the second elastic plate includes a flat portion surrounding the recess and a groove located between the recess and the flat portion.
  4. The piezoelectric pump according to claim 1, wherein at least one of the first elastic plate or the second elastic plate includes a protrusion protruding outward in an axial direction of the through-hole.

5. The piezoelectric pump according to claim 4, wherein the at least one of the first elastic plate or the second elastic plate includes a flat portion surrounding the protrusion and a groove located between the protrusion and the flat portion.

6. A pump unit, comprising:  
the piezoelectric pump according to claim 1; and  
a housing accommodating the piezoelectric pump, the housing including an outlet facing the communication hole in the first elastic plate.

\* \* \* \* \*