

(No Model.)

3 Sheets—Sheet 1.

J. Q. MARSH.  
DEAD PULLEY RIGGING.

No. 473,765.

Patented Apr. 26, 1892.

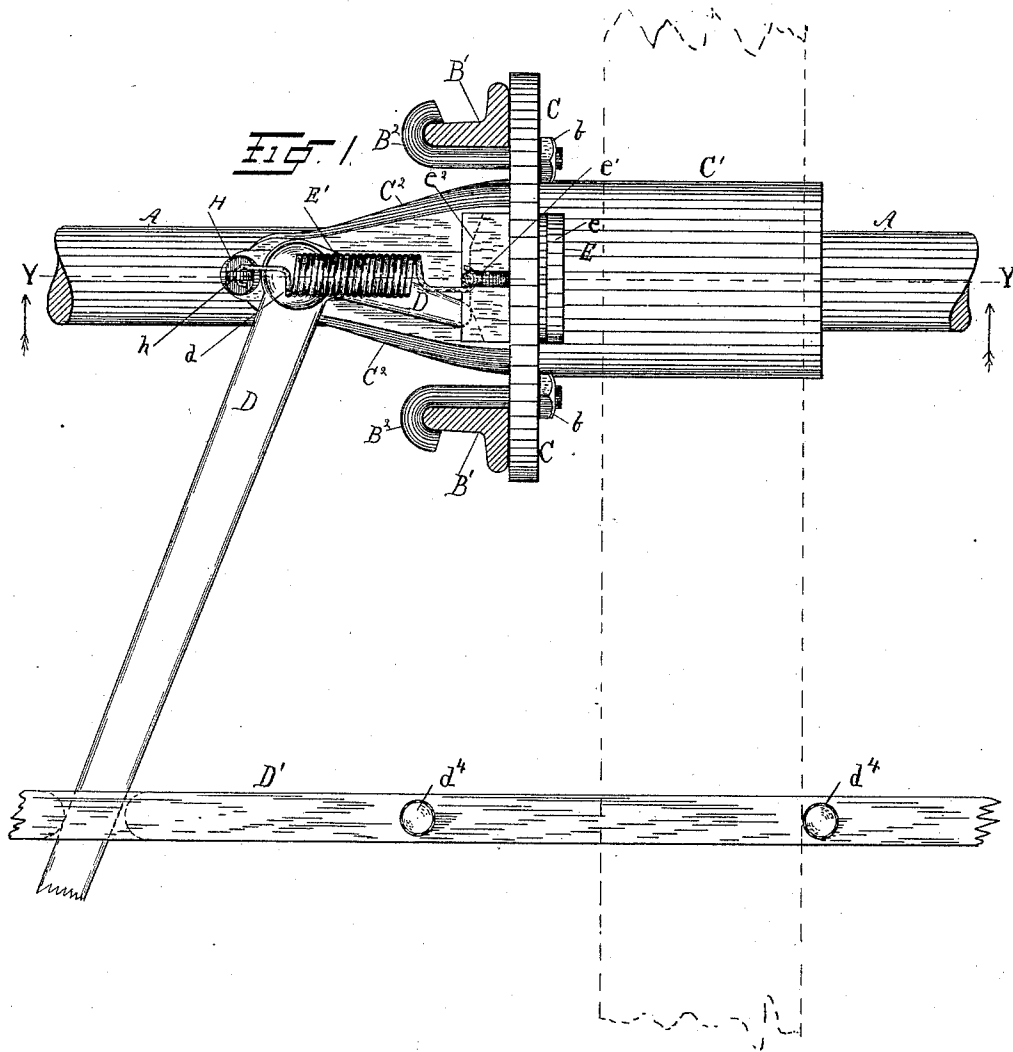

WITNESSES

*Wm. Marks, Jr.*  
*J. D. Otto.*

INVENTOR

*John Q. Marsh*  
*by Hallock & Hallack*  
*Attys*

(No Model.)

3 Sheets—Sheet 2.

J. Q. MARSH.  
DEAD PULLEY RIGGING.

No. 473,765.

Patented Apr. 26, 1892.

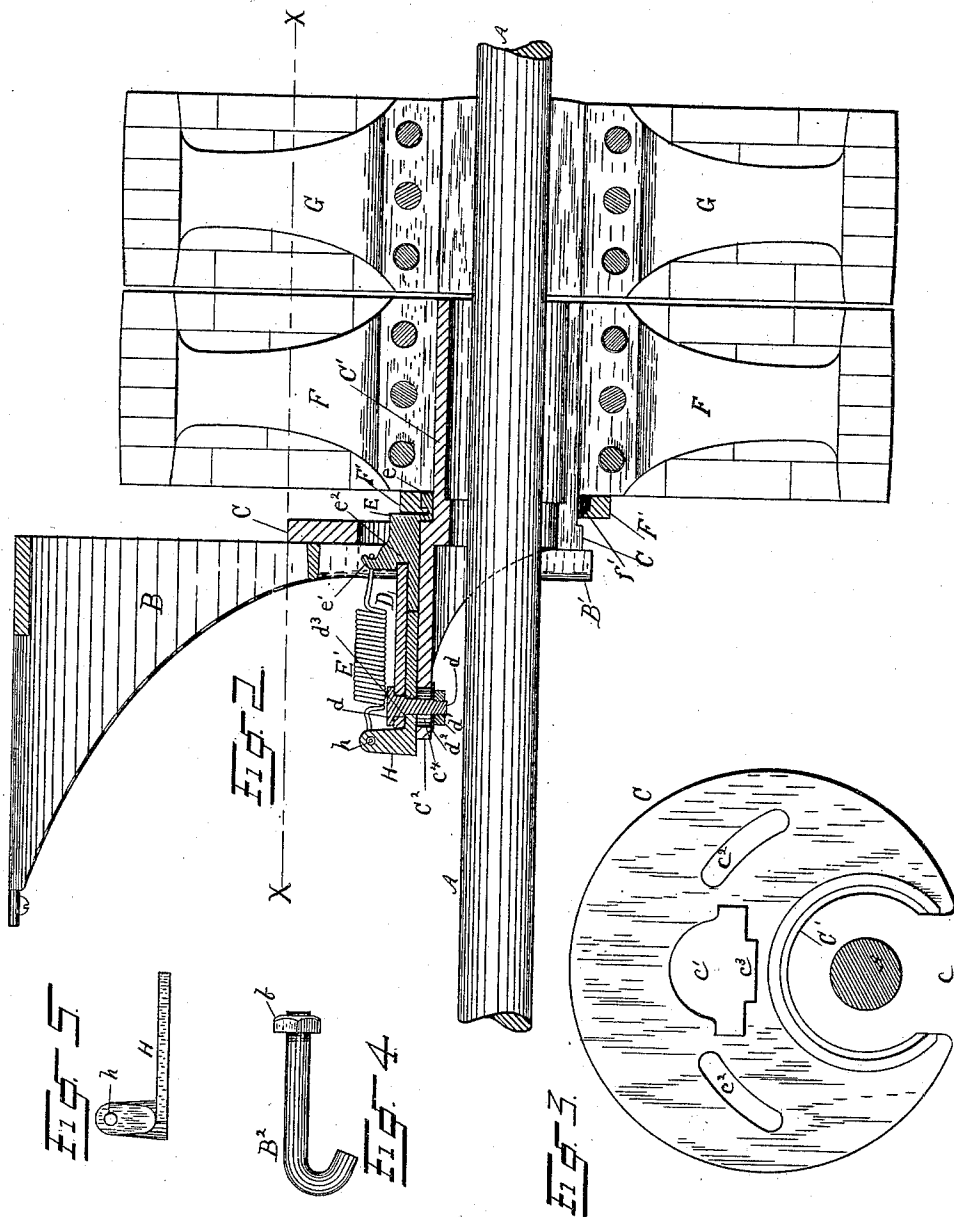

WITNESSES-  
*Wm. Marks Jr.*  
*J. D. Acton*

INVENTOR-  
*John Q. Marsh*  
 by *Hallcock & Hallcock*  
*his Atty*

(No Model.)

3 Sheets—Sheet 3.

J. Q. MARSH.  
DEAD PULLEY RIGGING.

No. 473,765.

Patented Apr. 26, 1892.

FIG 8

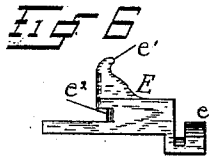
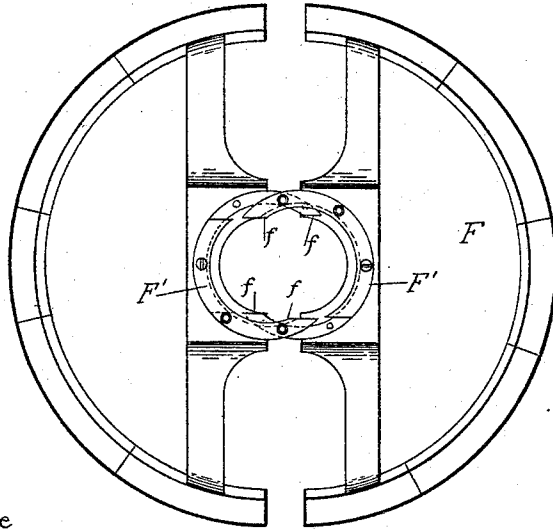

FIG 9

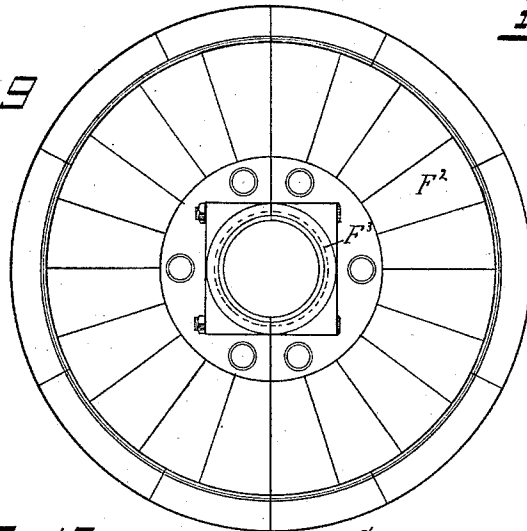

FIG 7

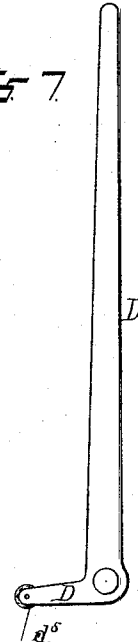
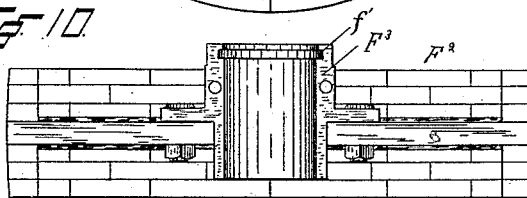

FIG 10



WITNESSES-

Wm. Marks Jr.  
J. D. Otto.

INVENTOR-

John D. Marsh  
by Hallock & Hallock  
his Atty

# UNITED STATES PATENT OFFICE.

JOHN Q. MARSH, OF ERIE, PENNSYLVANIA.

## DEAD-PULLEY RIGGING.

SPECIFICATION forming part of Letters Patent No. 473,765, dated April 26, 1892.

Application filed July 3, 1891. Serial No. 398,373. (No model.)

*To all whom it may concern:*

Be it known that I, JOHN Q. MARSH, a citizen of the United States, residing at Erie, in the county of Erie and State of Pennsylvania, have invented certain new and useful Improvements in Dead-Pulley Rigging; and I do hereby declare the following to be a full, clear, and exact description of the invention, such as will enable others skilled in the art to which it appertains to make and use the same.

This invention relates to the rigging of a dead-pulley; and it consists in certain improvements in the construction thereof, as will be hereinafter fully set forth, and pointed out in the claims.

My invention is illustrated in the accompanying drawings, as follows:

Figure 1 is a top plan view of my improved rigging for a dead-pulley, the hanger B being in horizontal section on the line X X in Fig. 2. Fig. 2 is a longitudinal vertical section, partly in elevation, taken on the line Y Y in Fig. 1. Fig. 3 is an end view, looking from the right of Fig. 2, of the bracket which supports the dead-pulley. Figs. 4, 5, 6, and 7 are views of parts detached from the device and will be referred to in place in the following description. Fig. 8 is a side view of a common wooden split pulley adapted to be used as a dead-pulley with my improved rigging, the split pulley being shown slightly separated. Fig. 9 is a like view of a common wooden webbed split pulley with a split iron hub adapted to be used with my improved rigging. Fig. 10 is an elevational view of one of the parts of the pulley shown in Fig. 9, the view showing the meeting face of the part.

In Fig. 2 the dead-pulley and the live-pulley or pulley, fixed to the shaft, are both shown in vertical section on their lines of parting, both being split wooden pulleys.

The construction of my device is as follows: A represents the driving or line shaft; B, the dead-pulley hanger; C C' C<sup>2</sup>, the bracket which supports the dead-pulley and the means for moving said pulley; F, the dead-pulley, and G the live-pulley.

Other letters of reference will be referred to in proper place herein.

The dead-pulley and its rigging can be put in place without disturbing the shaft A,

and, if necessary, without stopping it. The hanger B has two prongs or legs B' B', which straddle the shaft A, and it is fixed to the building-timbers above the shaft. The bracket C C' C<sup>2</sup> consists of a plate C, which is attached to the hanger-prongs B' by bolts B<sup>2</sup>, (seen in detail in Fig. 4,) which pass through slots c<sup>2</sup> in the plate, a horn or sleeve C', which serves as a journal for the dead-pulley and is provided with a longitudinal opening c along its under side to allow it to be slipped over the shaft, and a back extension C<sup>2</sup>, which supports the mechanism for moving the dead-pulley laterally. The bolts B<sup>2</sup>, which attach the bracket C C' C<sup>2</sup> to the hanger, pass through the slots c<sup>2</sup> and engage by their hooked ends with the legs B' of the hanger, as seen clearly in Fig. 1. The bracket can be adjusted upon the hanger by these bolts so as to bring the sleeve C' and the dead-pulley, which is journaled thereon, concentric with the shaft A, because the bracket can be adjusted both vertically and laterally on the hanger. By moving the bolts up or down on the hanger the bracket may be adjusted vertically, and as the slots c<sup>2</sup> are arc-formed and concentric with the sleeve C' if one bolt is moved up and the other down the bracket can be adjusted laterally. The object in having the slots c<sup>2</sup> curved concentric with the sleeve C' is to enable the bracket to be so adjusted that the top of the back extension C<sup>2</sup> may be set horizontal or at an angle, whereby the lever D, hereinafter to be described, may lie in a plane horizontal and parallel with the shaft or at an angle thereto.

E is a sliding block, which is guided in a groove c<sup>3</sup> on the back of the part C<sup>2</sup> of the bracket and extends through the opening c' in the plate C of the bracket. (See Fig. 3.) This sliding block, which is shown detached from the device in Fig. 6, has a lip e at one end, which engages an annular groove f' in a collar F' on the end of the hub of the dead-pulley, and it has also a cam-face e<sup>2</sup>, which is operated upon by the lever D, and also a horn e', to which a reacting spring E' is connected.

D is the shifting-lever. It is an elbow-lever and is pivoted by the bolt d to the back extension C<sup>2</sup> of the bracket. The short end of this lever acts upon the cam-face e<sup>2</sup> of the sliding block E and its long end extends out laterally from the shaft and engages the belt-shifting

bar  $D'$ , which has the ordinary pins  $d^1$   $d^4$  for contacting with the belt. If desired, the short end of the lever  $D$  may have a bearing-roller  $d^5$  to act upon the sliding block  $E$ , as seen in

5 Fig. 7.

It is desirable that the pivot  $d$  of the lever  $D$  may be adjustable from and toward the block  $E$ , so as to regulate the action of the lever upon the block  $E$ , as desired. To this  
10 end there is a slot  $c^4$  in the back extension  $C^2$  of the bracket, through which the pin  $d$  passes, and there is a plate  $H$  (see Fig. 5) above the bracket, with a round opening for the pin  $d$ , and there is a nut and washer  $d'$  and  $d^2$  on  
15 the pin below the bracket. The pin has a shoulder  $d^3$ , so that it is larger where it passes through the lever  $D$  than where it passes through the plate  $H$ . Hence when the nut  $d'$  is tightened the plate  $H$  is clamped upon  
20 the top of the bracket and the lever  $D$  is free to move. The plate  $H$  has a horn  $h$ , to which the reacting spring  $E'$  is connected.

In Fig. 8 it will be seen that the collar  $F'$  is not divided on the line on which the pulley  
25 is divided, but so as to make lap-joints  $f f f$ . In Fig. 9 the pulley  $F^2$  has a solid web in place of cross-arms, as in the pulley  $F$ , and it has a split iron hub  $F^3$ . These modifications are to show that the groove  $f'$  can be made in an  
30 iron hub like  $F^3$  as well as in a collar like  $F'$  and that, as shown in Fig. 8, the collar can be so parted as not to endanger forming an uneven surface to catch the engaging-lip  $e$  on the  
35 block  $E$ .

The operation of my device is as follows: Normally the position of parts, we will assume, is that of the dead-pulley at rest and carrying the belt. When the pulley is at rest and carrying the belt, the parts are in the position shown in Fig. 1. To shift the belt onto  
40 the live-pulley, the lever  $D$  is moved from the position shown in Fig. 1 toward the right. (The position of the belt is shown by dotted lines.) Such a movement of the lever  $D$  moves  
45 the bar  $D'$  to the right, and the short end of the lever acts upon the block  $E$  and slides it toward the right also. As this block is in engagement by the lip  $e$  with the dead-pulley, it moves the dead-pulley with it toward the  
50 live-pulley, against which it quickly impinges.

As soon as the dead-pulley abuts against the live-pulley it begins to rotate with it. By this time the short end of the lever  $D$  is acting upon the straight part of the cam-face  $e^2$ ,  
55 and hence the block is not being further moved, although the lever  $D$  is moving and the belt-pin  $d^4$  on the left of the belt is soon brought against the belt and moves it onto the live-pulley. When this movement is completed,  
60 the short end of the lever  $D$  has passed over the straight part of the cam-face  $e^2$ , and the reacting spring  $E'$  can then act and draw the block  $E$  back and the dead-pulley with it away from contact with the live-pulley. The dead-  
65 pulley then at once stops rotating and the belt is running on the live-pulley. The long end of the lever  $D$  will then be pointing to-

ward the right at about the angle it is shown to be pointing toward the left in the figure, and the short end is in contact with the inclined  
70 face of the cam  $e^2$  on the opposite side of the block from where it is shown in the figure. When it is desired to shift the belt back onto the dead-pulley, the lever is swung back into  
75 normal position, and in so moving it acts upon the cam  $e^2$  and moves the dead-pulley up against the live-pulley and gets it in rotation, and the belt is then shifted, and then the dead-pulley is drawn back away from the live-  
80 pulley by the spring  $E'$  and the parts are at normal, as seen in Fig. 1.

The advantages of my construction are that the rigging can be put up without disturbing the line-shaft, that the bracket  $C$   $C'$   $C^2$  can be adjusted both vertically and laterally on  
85 the hanger, and thereby bring the dead-pulley concentric with the shaft without care in mounting the hanger, and that the bracket can be so adjusted as to allow the lever  $D$  to stand horizontal or incline upward or down-  
90 ward from the shaft.

What I claim as new is—

1. In a dead-pulley rigging, the combination, with the hanger  $B$   $B'$ , of a bracket having  
95 the plate  $C$  for attachment with said hanger, the slotted sleeve  $C'$  on one side of said plate, embracing the shaft  $A$  for journaling the dead-pulley concentrically with said shaft, and the part  $C^2$  on the opposite side of said  
100 plate and above said shaft for supporting the mechanism for laterally moving the dead-pulley, and means for adjusting said bracket both laterally and vertically on said hanger.

2. In a dead-pulley rigging, the combination of the hanger  $B$   $B'$ , the bracket  $C$   $C'$   $C^2$ ,  
105 adjustably attached to said hanger and embracing the shaft  $A$ , a dead-pulley journaled on the sleeve  $C'$  of said bracket, the sliding block  $E$ , guided in ways on the top of the back extension  $C^2$  of said bracket and having  
110 means for engaging said dead-pulley, and the lever  $D$ , pivoted on the back extension  $C^2$  of said bracket, for moving said sliding block  $E$  in opposite directions.

3. In a dead-pulley rigging, the combination of a hanger  $B$   $B'$ , a bracket  $C$   $C'$   $C^2$ ,  
115 adjustably attached to said hanger and embracing the shaft  $A$ , a dead-pulley journaled on the sleeve  $C'$  of said bracket, the sliding block  $E$ , guided in ways on said bracket and having means for engaging said dead-pulley,  
120 and the lever  $D$  and spring  $E'$ , supported on the part  $C^2$  of said bracket, for moving said sliding block  $E$  in opposite directions.

4. In a dead-pulley rigging, the combination of a hanger, a bracket adjustably secured  
125 to said hanger, a sleeve forming part of said bracket, which is slotted to straddle the shaft and form a journal for the dead-pulley, a dead-pulley journaled on said sleeve and movable laterally thereon, a block guided to  
130 slide longitudinally on the top of the back extension  $C^2$  of said bracket and engaging with said dead-pulley, a shifting-lever pivoted on said back extension and acting with

the short end upon said sliding block, and a belt-shifting bar carried by the long end of said lever.

5 In a dead-pulley rigging, the combination of a fixed supporting-journal for the dead-pulley, which embraces the shaft, a split dead-pulley mounted on said fixed support, a split grooved collar F' on said pulley having lap-joints *ffff*, a sliding block having a lip

for engaging said grooved collar and movable in ways on said fixed support, and means for moving said block.

In testimony whereof I affix my signature in presence of two witnesses.

JOHN Q. MARSH.

Witnesses:

JNO. K. HALLOCK,

A. A. FREEMAN.