

C. B. Turner.

Rotary Steam-Engine.

N^o 74172

Patented Feb. 4, 1868

Fig. 1.

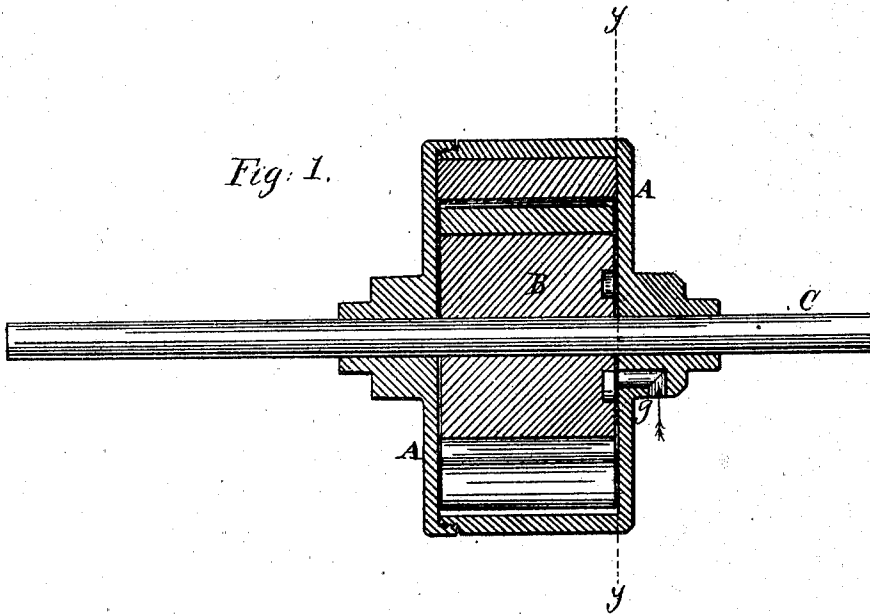
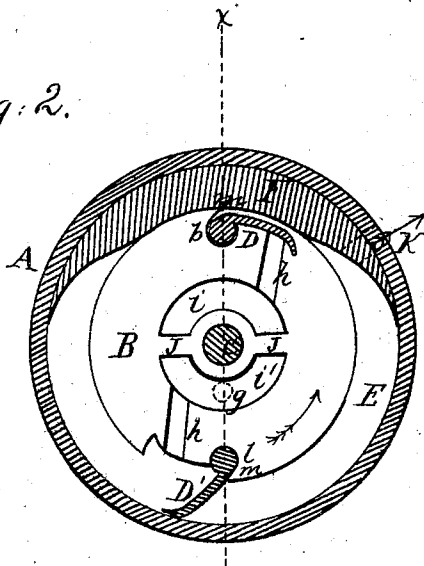

Fig. 2.



Witnesses:

W. C. Asakettle
Theo. Tucke.

Inventor:

Chester B. Turner
per Munn & Co
Attorneys

United States Patent Office.

CHESTER B. TURNER, OF GRAND RAPIDS, MICHIGAN.

Letters Patent No. 74,172, dated February 4, 1868.

IMPROVEMENT IN ROTARY STEAM-ENGINES.

The Schedule referred to in these Letters Patent and making part of the same.

TO ALL WHOM IT MAY CONCERN:

Be it known that I, CHESTER B. TURNER, of Grand Rapids, in the county of Kent, and State of Michigan, have invented a new and improved Rotary Steam-Engine; and I do hereby declare that the following is a full, clear, and exact description thereof, which will enable those skilled in the art to make and use the same, reference being had to the accompanying drawings, forming part of this specification.

This invention relates to an improvement in rotary steam-engines, and consists in constructing the piston with small steam-chambers or recesses upon its face, said chambers being divided by partitions or gates, which, together with the recesses, are arranged to operate in connection with the induction-port and valves, as will be hereinafter more fully described.

Figure 1 represents a vertical section of the engine through the line *x x* of fig. 2.

Figure 2 is a section through the line *y y* of fig. 1.

Similar letters of reference indicate corresponding parts.

A is the cylinder of the engine. B is the piston-core or centre, which is attached to the driving-shaft C. D D' represent wings or valves, which are loosely hinged to the centre B. E represents an annular space, between the piston-core B and the inside of the cylinder. To this annular space the steam is admitted, where it operates upon the wings, thereby imparting motion to them and to the main shaft C. F is a double-cam block, which fills the annular space E, the central portion of which conforms in shape to the piston-core, forming a steam-tight joint therewith, as seen in the drawing. From this central portion, it slopes at each end to a point, forming cams, which, in the rotation of the piston, close the wings alternately as they pass. The steam-orifice is seen at *g*. The steam-ports (one for each wing) are marked *h h*. *i i* represent small steam-chambers or recesses made in the piston-core. These separate chambers are divided by partitions, J J, which cut off the steam at the desired points, as the piston with the wings revolves.

The piston is supposed to be moving in the direction of the arrow. When one of the chambers is in communication with the orifice *g*, that wing is taking steam through its port *h*, and it will be seen that, by properly arranging the partitions J, or by making them broader or narrower, the steam can be cut off at any desired point in the stroke or revolution, and act by its expansive force.

K is the exhaust-port. When one of the wings, D, has passed the exhaust-port, and is closed by the cam, as seen in the drawing, the steam is exhausting behind the other wing, D'. When the chamber *i* comes into communication with the steam-orifice *g*, the wing D will be taking steam, and so on alternately. The wings or valves D D' are attached to the piston-core, so as to drop into their respective cylindrical recesses *l l*, where they turn as on a hinge. Behind each wing, it will be seen that there is a lip or stay, *m*, which supports the wing as it is thrown back by the steam, and after friction with the cylinder has reduced the wing in width somewhat.

Having thus described my invention, I claim as new, and desire to secure by Letters Patent—

The piston B, provided with the partitions J and chambers *i*, and arranged to operate in connection with the induction-port *g* and valves D and D', as herein described and represented.

Witnesses:

A. B. TURNER,
ALBERT BAXTER.

CHESTER B. TURNER.