

May 21, 1935.

J. TRELOAR
STEAM GENERATOR

2,002,254

Filed March 13, 1934

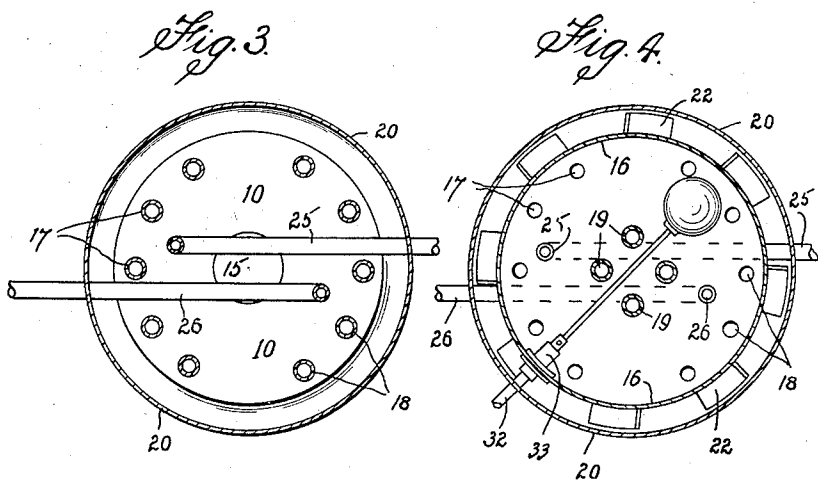
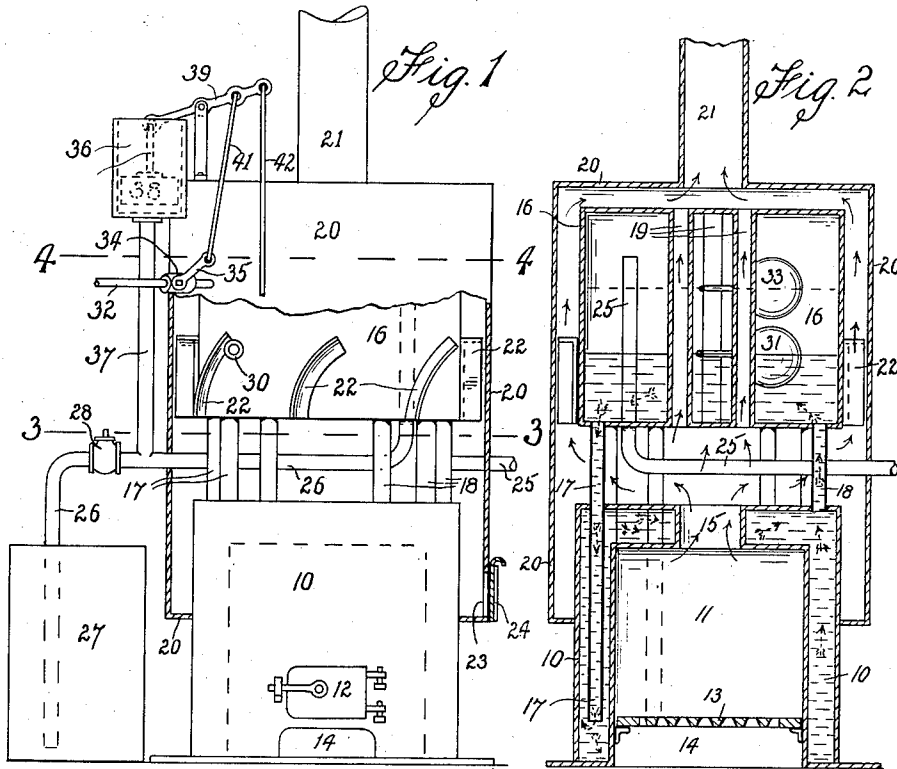

Inventor:
James Treloar
By *L. L. Quigley*
Attorney.

UNITED STATES PATENT OFFICE

2,002,254

STEAM GENERATOR

James Treloar, Hamilton, New Zealand

Application March 13, 1934, Serial No. 715,358
In New Zealand March 30, 1933

6 Claims. (Cl. 122—451)

This invention has been devised with the object of providing an improved construction of generator for the production of low pressure steam such as may be used on dairy farms and in like circumstances where supplies of steam at low pressure are required for various purposes. The features of construction forming the novel features of the invention may, however, be adapted to a construction of generator designed for high steam pressures being generated.

The invention consists in a novel construction of boiler device in which the heat is obtained by the combustion of suitable fuel within a furnace space and it embodies also novel control means for automatically controlling the supply of water to the boiler in direct correspondence with the steam pressure produced to cause such supply to be increased when the pressure increases, as through a high fire, and then as pressure is reduced, will cut off this extra supply and maintain the supply through a normally acting means.

The construction designed comprises broadly two water holding chambers disposed one above the other with a space between and connected together by circulating tubes, and the lower of which chambers surrounds a furnace space and the upper of which chambers is connected to the water supply, combined with a casing surrounding the sides and top of the upper chamber, so as to leave spaces between, which casing is in communication with the top of the said furnace space in order that the furnace heat, after passing from the inside of the lower chamber, will pass all round the upper chamber on its way to the escape flue. The construction also comprises other detail features, provided to increase the general efficiency and control of the generator's operations, which will be hereinafter more fully referred to.

The invention is illustrated in the accompanying drawing, in which:—

Figure 1 is an elevation of the generator, the lower part of the casing being in section.

Figure 2 is a full sectional elevation thereof.

Figure 3 is a sectional plan on the line 3—3 of Figure 1.

Figure 4 is a sectional plan on the line 4—4 of Figure 1.

The generator, as made in accordance herewith, may be of any approved shape in plan, as rectangular or circular, but is preferably made of the circular shape shown in the drawing and will be described as being of such shape.

In giving effect to the invention a lower cylindrical boiler chamber 10 is provided, such being

made with an internal furnace space 11 the walls and top of which are disposed within the chamber 10 so that a water holding space is left between their walls and tops. This furnace space 11 is made to open out through a fire door 12 on one side, and is fitted with a fire grate 13 above an ashpit 14, in a well known manner. Such an arrangement allows for ordinary wood or coal fuel being used, but it is to be understood that any other desired heating agency, such as electricity, oil fuel and the like, may be used for the purposes of the invention, the furnace being adapted to suit the particular agency employed.

A vent passage 15 is provided to pass from the centre of the furnace 11 out through the top of the chamber.

An upper enclosed cylindrical chamber 16 is provided and such is arranged a distance above the chamber 10 to leave a clear space between them. This is placed in water circulatory connection with the chamber 10 by means of a series of tubes 17 which are disposed in one half of a circular line around near the edges of the chambers to extend from the bottom of the chamber 16 vertically downward within the chamber 10 to points near the bottom thereof, and by a second series of tubes 18 arranged in the other half of the circular line and extending from the bottom of the chamber 16 into the top of the chamber 10. These tubes may be used to carry the chamber 16 upon the chamber 10, although other supporting means may be used if so desired.

A series of heat tubes 19 are provided at about the middle of the chamber 16 to extend throughout its full height.

A casing 20 is provided to encircle the upper chamber 16 and to extend down its outside below the space between the two chambers and to overlap the lower chamber a distance. This also extends across the top of the upper chamber and is provided with a centrally disposed escape flue 21. It is so made and arranged as to leave an annular space between it and the chambers and a space above the chamber 16.

Thus the heat flames or gases, after acting on the inside shell of the boiler chamber 10, will pass up out through the vent 15 and out into the space between the chambers to act on the top of one and the bottom of the other and upon the tubes 17 and 18, and will then pass up round the wall of the chamber 16 and across its top, to the escape flue 21. A proportion of the heat will also pass up through the tubes 19. In this manner the heat from the furnace is brought into intimate

association with both of the chambers 16 and 16 to effectively heat their contents.

To obtain a more effective use of the heat passing up the outside of the chamber 16, such chamber may be provided with a series of baffle plates 22 secured upon its outside and extending across the space between it and the casing 20, which plates are shaped to extend in a concave curve upwardly and circumferentially. The baffle plates act to intercept the heat gases and impart a whirling action thereto, which concentrates the heat upon the chamber wall for a longer period, and also provides for the storage of an amount of heat in the heating of the plates themselves which heat is imparted by conduction to the inside of the chamber.

The casing 20 in its lower part may be formed with an outlet opening 23 covered by a door 24 to permit of the removal of any ash that may be precipitated into its bottom end and collect there. More than one of these may be provided if so required.

The chamber 16 is supplied with water to a desired level which causes the boiler chamber also to be filled, and this water is heated by the heat of and from the furnace space and caused to circulate from one chamber to another by passing down through the tubes 17 and up through 18 in the manner shown by the dotted arrows. The steam generated collects in the top of the chamber 16 and from thence it is led away for use through a draw off pipe 25 which passes from within the top of the chamber, down through its bottom, and then across within the space between the two chambers to the outside. A second escape pipe 26 is provided for the outlet of the steam from the generator when an excess of steam is being generated, and this also passes in a similar manner through the heated space between the two chambers and then is carried down into the bottom of a water tank 27 the water in which seals this outlet when the steam pressure in the generator remains normal but allows it to escape when it exceeds the normal. Such steam then serves to heat the water in the tank so that it may be used for any purpose for which hot water is required.

This manner of withdrawing the steam, either through the pipe 25 or pipe 26, will result in the steam being superheated as it passes through the space heated from the furnace, seeing that the pipes are under the heat action. This feature also provides for a prolonged generation of steam when the furnace heat decreases, seeing that as the internal pressure in the generator falls below that of the atmosphere, water will flow back through the pipe 26 and will be acted upon by the heated tube, to be converted into steam. In order however that any flooding of the generator through such backflow may be prevented, the pipe 26 has a relief valve 28 arranged therein, which is adjusted to operate just as the pipe becomes filled with the water column.

The water supply to the chamber 16 is maintained automatically at a normal level by being introduced into the chamber through an inlet pipe 30, that is controlled by an ordinary cock actuated by a float 31 within the chamber, in a well known way. Provision is, however, made for a supply to above this level being automatically obtained should the steam pressure within the generator exceed a predetermined degree, so that the reduction of the pressure may thus be brought about, and then when the pressure has been reduced, for the source of additional water supply being cut off.

Means for this purpose are shown in the drawing and comprise a second supply pipe 32 arranged to enter the chamber 16 at a higher level than the supply pipe 30, and having also its float controlled cock 33 to open and close it as the level falls away, or reaches the required height. It is, in addition, controlled by a cock 34 situated outside the casing, such cock being actuated to open by the lowering of a lever handle 35 and to close with the raising of such handle. An open topped steam cylinder 36 is mounted on the casing above and this at its lower end is connected with the steam pipe 26 by a branch 37. A weighted plunger 38 fits inside the cylinder, and the steam pressure in the generator thus acts on the underside of this plunger. Normally the plunger remains down in the cylinder, but when the pressure increases above normal it raises the plunger in the cylinder. A rocking beam 39 is mounted also on the casing top, with one end extending across the top of the cylinder 36 and this is attached by a connecting rod 40, to the plunger 38. Its other end is then connected by rod 41 with the lever handle 35 of the cock 34 so that through the lowering of the plunger, the cock is closed, and on the raising thereof, the cock is opened to feed water through the pipe 32, which feed is then controlled by the float cock 33.

If desired a second rod 42 may be led down from the inner end of the rocking beam 39 to actuate a damper on the furnace door 12 (not shown) to open and close it with the respective downward and upward movements of the beam, and thus to regulate the draught of the furnace and control the heat in correspondence with the generation of steam.

The generator thus formed is made and assembled in accordance with the usual practice concerned in the manufacture of steam generators of this class, this specification and the accompanying drawing indicating only the features of construction with which the invention is concerned.

I claim:—

1. Steam generating means, comprising in combination, a boiler chamber having an internal furnace space and an exit passage therefrom through the chamber top, an enclosed water receiving chamber arranged above the boiler chamber, at a distance therefrom, and having a number of heat tubes extending vertically through its full length, water circulating tube connections between the two chambers, and a casing enclosing the upper chamber and the space between the two chambers, made to leave a clear space between it and the sides and top of the upper chamber and provided with an outlet flue leading from its top.

2. In a steam generator according to claim 1, circulating water tubular connections between the two chambers arranged as to one half thereof to extend from the bottom of the upper chamber down into near the bottom of the lower chamber and as to the other half, to extend from the top of the lower chamber into the bottom of the upper chamber.

3. In a steam generator according to claim 1, means for feeding water to the said upper chamber comprising a float actuated cock situated at one level inside the chamber and controlling a water supply pipe, a second float actuated cock situated at a higher level inside the chamber and controlling a second water supply pipe, a cock further controlling such second supply pipe, and means actuated by the steam pressure within the

chamber, whereby such cock is opened when the pressure exceeds a predetermined degree and is closed when the pressure falls below such degree, substantially as specified.

5 4. In a steam generator according to claim 1, means for feeding water to the said upper chamber comprising a float actuated cock situated at one level inside the chamber and controlling a water supply pipe, a second float actuated cock
10 situated at a higher level inside the chamber and controlling a second water supply pipe, a cock further controlling such second supply pipe, a lever handle for actuating the said cock, a vertical steam cylinder having its lower end connected with the upper chamber, a weighted
15 plunger fitted in such cylinder, and a rocking beam mounted above the cylinder and having one end connected with the said plunger and its other end connected with the lever handle of the said cock, whereby such cock is opened when the
20 pressure exceeds a predetermined degree and

is closed when the pressure falls below such degree, substantially as specified.

5 5. In a steam generator according to claim 1, a steam draw off pipe leading from within the top of the upper chamber, down through the bottom thereof and across within the space between the two chambers to outside the casing, and a safety steam escape pipe passing similarly from inside the top of the said chamber to without the casing and extending down within a water storage tank, substantially as and for the purposes
10 specified.

15 6. In a steam generator according to claim 1, the combination with the said upper chamber, of a number of baffle plates affixed to its outer surface to project across the space between this chamber and the casing, and each shaped to extend at an inclining curve a distance up the height of the chamber substantially as and for the purposes specified.
20

JAMES TRELOAR.