

(19) World Intellectual Property Organization  
International Bureau



(43) International Publication Date  
16 February 2012 (16.02.2012)

(10) International Publication Number  
**WO 2012/021542 A2**

(51) International Patent Classification:  
A61B 8/00 (2006.01)

(21) International Application Number:  
PCT/US2011/047127

(22) International Filing Date:  
9 August 2011 (09.08.2011)

(25) Filing Language: English

(26) Publication Language: English

(30) Priority Data:  
61/372,044 9 August 2010 (09.08.2010) US  
12/900,750 8 October 2010 (08.10.2010) US

(71) Applicant (for all designated States except US): **C.R. BARD, INC.** [US/US]; 730 Central Avenue, Murray Hill, NJ 07974 (US).

(72) Inventors; and

(75) Inventors/Applicants (for US only): **LINDEKUGEL, Eric, W.** [US/US]; 1381 Hudson Avenue, Salt Lake City, UT 84106 (US). **COX, Jeremy, B.** [US/US]; 685 Eighth Avenue, Salt Lake City, UT 84103 (US). **BLANCHARD, Daniel, B.** [US/US]; 4507 Summerwood Drive, Bountiful, UT 84010 (US). **CROOK, Christian, W.** [US/US]; 6948 West 7895 South, West Jordan, UT 84081 (US). **BURNSIDE, Eddie, K.** [US/US]; 436 East Premier Lane,

Grantsville, UT 84029 (US). **SOUTHARD, Jeanette, E.** [US/US]; 120 Paradise Road, Park City, UT 84098 (US). **STINGER, Kevin, W.** [US/US]; 963 Mary Margret Drive, Kaysville, UT 84037 (US).

(74) Agent: **WIGHT, Todd, W.**; Rutan & Tucker LLP, 611 Anton Boulevard, Suite 1400, Costa Mesa, CA 92626 (US).

(81) Designated States (unless otherwise indicated, for every kind of national protection available): AE, AG, AL, AM, AO, AT, AU, AZ, BA, BB, BG, BH, BR, BW, BY, BZ, CA, CH, CL, CN, CO, CR, CU, CZ, DE, DK, DM, DO, DZ, EC, EE, EG, ES, FI, GB, GD, GE, GH, GM, GT, HN, HR, HU, ID, IL, IN, IS, JP, KE, KG, KM, KN, KP, KR, KZ, LA, LC, LK, LR, LS, LT, LU, LY, MA, MD, ME, MG, MK, MN, MW, MX, MY, MZ, NA, NG, NI, NO, NZ, OM, PE, PG, PH, PL, PT, QA, RO, RS, RU, SC, SD, SE, SG, SK, SL, SM, ST, SV, SY, TH, TJ, TM, TN, TR, TT, TZ, UA, UG, US, UZ, VC, VN, ZA, ZM, ZW.

(84) Designated States (unless otherwise indicated, for every kind of regional protection available): ARIPO (BW, GH, GM, KE, LR, LS, MW, MZ, NA, SD, SL, SZ, TZ, UG, ZM, ZW), Eurasian (AM, AZ, BY, KG, KZ, MD, RU, TJ, TM), European (AL, AT, BE, BG, CH, CY, CZ, DE, DK, EE, ES, FI, FR, GB, GR, HR, HU, IE, IS, IT, LT, LU,

[Continued on next page]

(54) Title: SUPPORT AND COVER STRUCTURES FOR AN ULTRASOUND PROBE HEAD

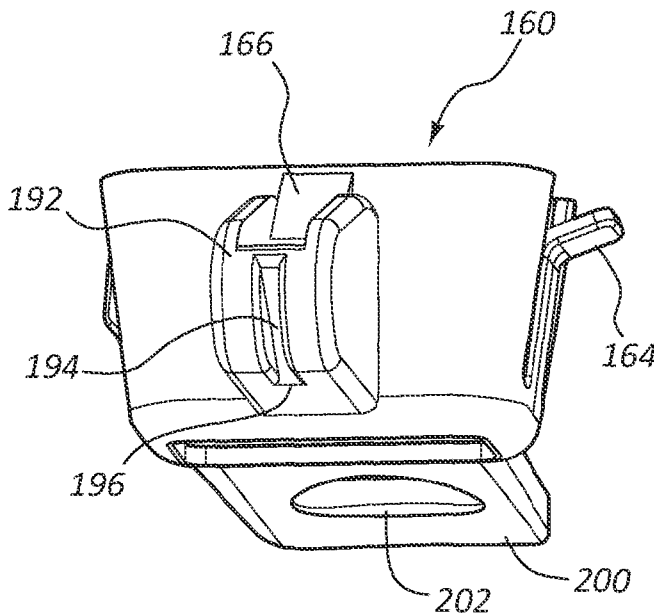
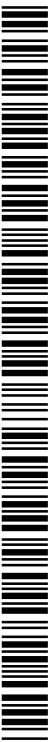


FIG. 25D

(57) Abstract: A probe cap for use with an ultrasound probe including a head portion and an acoustic surface is disclosed. In one embodiment, the probe cap includes a body that defines a cavity sized for releasably receiving the head portion of the probe therein. The probe cap body further defines a hole that is proximate the acoustic surface of the head portion. A compliant spacer component is disposed in the hole. The spacer component can include a hydrogel and provides an acoustic path between the acoustic surface and a tissue surface of a patient. The spacer component includes a skin contact surface that defines a concavity and is deformable against the tissue surface. Additional embodiments disclose various probe cap and accompanying needle guide designs for use in assisting a clinician with ultrasound probe use and needle insertion into a patient.



WO 2012/021542 A2

LV, MC, MK, MT, NL, NO, PL, PT, RO, RS, SE, SI, SK,  
SM, TR), OAPI (BF, BJ, CF, CG, CI, CM, GA, GN, GQ,  
GW, ML, MR, NE, SN, TD, TG).

— *of inventorship (Rule 4.17(iv))*

**Published:**

**Declarations under Rule 4.17:**

— *as to applicant's entitlement to apply for and be granted  
a patent (Rule 4.17(ii))*

— *without international search report and to be republished  
upon receipt of that report (Rule 48.2(g))*

**SUPPORT AND COVER STRUCTURES FOR AN ULTRASOUND PROBE HEAD****CROSS-REFERENCE TO RELATED APPLICATIONS**

[0001] This application is a continuation-in-part of U.S. Application No. 12/900,750, filed October 8, 2010, and entitled "Spacers for Use with an Ultrasound Probe." This application also claims the benefit of U.S. Provisional Patent Application No. 61/372,044, filed August 9, 2010, and entitled "Support and Cover Structures for an Ultrasound Probe Head." Each of these applications is incorporated herein by reference in its entirety.

**BRIEF SUMMARY**

[0002] Briefly summarized, embodiments of the present invention are directed to a probe cap for use with an ultrasound probe including a head portion and an acoustic surface. In one embodiment, the probe cap includes a body that defines a cavity sized for releasably receiving the head portion of the probe therein. The probe cap body further defines a hole that is proximate the acoustic surface of the head portion. A compliant spacer component is disposed in the hole. The spacer component can include a hydrogel and provides an acoustic path between the acoustic surface and a tissue surface of a patient. The spacer component further includes a skin contact surface that defines a concavity and is deformable against the skin. The skin contact surface can further define one or more spacer elements adjacent the concavity for distributing the load of the probe pressing against the skin and preventing compression of subcutaneous structures of the patient.

[0003] In another embodiment, an ultrasound imaging system for imaging a subcutaneous structure of a patient is disclosed and includes a display, an ultrasound probe including an acoustic surface from which ultrasound signals are emitted, and first and second spacer elements. The spacer elements are positioned proximate opposite ends of the acoustic surface and are configured to provide a gap between the acoustic surface and a tissue surface of the patient. So configured, the spacer elements prevent compression of the subcutaneous structure of the patient.

[0004] In addition, embodiments to be further described below disclose various probe cap and accompanying needle guide designs for use in assisting a clinician with ultrasound probe use and needle insertion into a patient.

[0005] These and other features of embodiments of the present invention will become more fully apparent from the following description and appended claims, or may be learned by the practice of embodiments of the invention as set forth hereinafter.

### **BRIEF DESCRIPTION OF THE DRAWINGS**

[0006] A more particular description of the present disclosure will be rendered by reference to specific embodiments thereof that are illustrated in the appended drawings. It is appreciated that these drawings depict only typical embodiments of the invention and are therefore not to be considered limiting of its scope. Example embodiments of the invention will be described and explained with additional specificity and detail through the use of the accompanying drawings in which:

[0007] FIGS. 1A and 1B are perspective and side views, respectively, of an ultrasound probe including spacer elements configured in accordance with one embodiment;

[0008] FIG. 2 is a simplified cross sectional view of the ultrasound probe of FIGS. 1A and 1B used to image a vessel of a patient;

[0009] FIG. 3 is a side view of the ultrasound probe of FIGS. 1A and 1B enclosed within a sheath in accordance with one embodiment;

[00010] FIGS. 4A and 4B are side views of a portion of an ultrasound probe including spacer elements and further showing examples of possible acoustic surface configurations in accordance with one embodiment;

[00011] FIG. 5 is a side view of a portion of an ultrasound probe including a spacer element in accordance with one embodiment;

[00012] FIG. 6 shows ultrasound spacer elements configured in accordance with one embodiment;

[00013] FIG. 7 shows ultrasound spacer elements configured in accordance with one embodiment;

[00014] FIG. 8 shows ultrasound spacer elements configured in accordance with one embodiment;

[00015] FIGS. 9A and 9B show spacer elements configured in accordance with one embodiment;

[00016] FIG. 10 is a side view of an ultrasound probe including spacer elements configured in accordance with one embodiment;

[00017] FIG. 11 is a side view of an ultrasound probe including a cap including spacer elements and a sheath in accordance with one embodiment;

[00018] FIG. 12 is a perspective view of a spacer component in accordance with one embodiment;

[00019] FIGS. 13A-13C show use of the spacer component of FIG. 12 in accordance with one embodiment;

[00020] FIG. 14 is a side view of a spacer component in accordance with one embodiment;

[00021] FIGS. 15A-15B show use of the spacer component of FIG. 14 in accordance with one embodiment;

[00022] FIG. 16 is an exploded perspective view of an ultrasound probe and a probe cap in accordance with one embodiment;

[00023] FIGS. 17A-17D are various views of the probe cap of FIG. 16;

[00024] FIGS. 18A and 18B are an exploded perspective view and cross sectional side view of an ultrasound probe/probe cap and a spacer component, respectively;

[00025] FIG. 19 is a cross sectional view of a head portion of the ultrasound probe of FIG. 16;

[00026] FIG. 20 is a cross sectional view of the probe cap of FIG. 16;

[00027] FIG. 21 is a cross sectional view of a head portion of the ultrasound probe of FIG. 16 received within the probe cap of FIG. 16;

[00028] FIG. 22 is another cross sectional view showing a head portion of the ultrasound probe of FIG. 16 received within the probe cap of FIG. 16;

[00029] FIG. 23 is a perspective view of a mated configuration of the ultrasound probe and probe cap of FIG. 16;

[00030] FIGS. 24A and 24B are front and side views, respectively, of an ultrasound probe and accompanying probe cap including a compliant spacer component according to one embodiment;

[00031] FIG. 24C is a perspective view of the probe cap of FIGS. 24A and 24B;

[00032] FIGS. 25A-25D are various views of a probe cap according to one embodiment;

[00033] FIGS. 26A and 26B are various exploded views of a probe cap configured according to one embodiment;

[00034] FIG. 27 is a side view of the probe cap of FIGS. 26A and 26B shown in contact with a patient's skin above a subcutaneous vessel;

[00035] FIGS. 28A and 28B are perspective and cross sectional views, respectively, of a probe cap according to one embodiment;

[00036] FIGS. 29A-29D are various views of a probe cap assembly according to one embodiment;

[00037] FIGS. 30A and 30B are various perspective views of a probe cap according to one embodiment;

[00038] FIG. 31 is a cross sectional side view of the probe cap of FIGS. 30A and 30B shown attached to an ultrasound probe;

[00039] FIG. 32 is a perspective view of a probe cap according to one embodiment;

[00040] FIGS. 33A and 33B are partial cross sectional side views of an ultrasound probe and probe cap in accordance with one embodiment;

[00041] FIG. 34 is a perspective view of a needle guide according to one embodiment; and

[00042] FIGS. 35A and 35B are side and perspective views, respectively, of the needle guide of FIG. 34 attached to a probe cap according to one embodiment.

### DETAILED DESCRIPTION OF SELECTED EMBODIMENTS

[00043] Reference will now be made to figures wherein like structures will be provided with like reference designations. It is understood that the drawings are diagrammatic and schematic representations of exemplary embodiments of the present invention, and are neither limiting nor necessarily drawn to scale.

[00044] For clarity it is to be understood that the word “proximal” refers to a direction relatively closer to a clinician using the device to be described herein, while the word “distal” refers to a direction relatively further from the clinician. For example, the end of a catheter placed within the body of a patient is considered a distal end of the catheter, while the catheter end remaining outside the body is a proximal end of the catheter. Also, the words “including,” “has,” and “having,” as used herein, including the claims, shall have the same meaning as the word “comprising.”

[00045] Embodiments of the present invention are generally directed to various components for spacing an acoustic surface of an ultrasound probe from a tissue surface of a patient during ultrasound procedures to image subcutaneous tissues of the patient. Such ultrasound procedures are employed, for instance, in connection with the placement of a catheter within a vessel of the patient. As will be described, the components for spacing the acoustic surface in one embodiment prevent undesired compression of subcutaneous vessels, especially superficial vessels, which in turn improves the imaging of such vessels by the probe. In addition, embodiments to be described further below disclose various probe cap and accompanying needle guide designs for use in assisting a clinician with ultrasound probe use and needle insertion into a patient.

[00046] Reference is first made to FIGS. 1A and 1B, which depict an ultrasound imaging system 10 according to one embodiment, including an ultrasound probe 12 and a console 20 including a display 30 for depicting an image produced by the probe. In the present embodiment, the probe 12 is operably connected to the console 20 via a cable 31, though in one embodiment the probe can be wirelessly connected thereto.

[00047] The probe 12 includes a head 32 defined by a longitudinal length 32A and a width 32B. The body of the probe generally defines a front face 33A, a rear face 33B, and side faces 33C. It should be appreciated that the preceding description of the probe is not meant to limit application of the principles described herein in any way. The probe head 32

includes an acoustic surface 34 extending along at least a portion of a longitudinal length 32A of the probe head from which ultrasonic impulses are emitted in order to penetrate and image subcutaneous portions of the patient. Note that the size, shape and configuration of both the probe and acoustic surface can vary from what is described herein while still residing within the principles of the present disclosure. Note also that FIG. 1A shows just one example of an ultrasound imaging system; other systems including other components can also benefit from the principles described herein.

**[00048]** As depicted in FIGS. 1A and 1B, in accordance with one embodiment the probe head 32 includes two spacer elements, generally depicted at 40, disposed adjacent the probe acoustic surface 34 at each end of the longitudinal length 32A. Each spacer element 40 acts as an extended surface to provide a gap 48 between the acoustic surface 34 and the skin 36 or other tissue surface of the patient, as further described below, when the probe 12 is placed on the patient's skin for use in subcutaneous imaging.

**[00049]** In greater detail, each spacer element 40 in the present embodiment defines a blade-like extended surface that includes a contact surface 42 for contacting the tissue/skin 36 of the patient. The contact surface 42 can be shaped in one of several configurations, as will be discussed further below.

**[00050]** Reference is now made to FIG. 2. When no spacers are present on an ultrasound probe, the acoustic surface thereof directly contacts the patient's skin during imaging, which can cause a downward pressure sufficient to undesirably compress a subcutaneous vessel disposed beneath the probe. Further, the proximity of the probe acoustic surface to the patient's skin can cause the focal point of the probe to reside below the vessel to be imaged, resulting in less than optimal image resolution of superficial vessels or other objects residing relatively close to the skin surface.

**[00051]** In contrast to the above, FIG. 2 shows the probe 12 including the spacer elements 40 disposed at each longitudinal end of the probe head 32 and adjacent the acoustic surface 34. So configured, the acoustic surface 34 is spaced apart from the patient's skin 36 during probe use, and only the contact surfaces 42 of the spacer elements 40 are in contact therewith. The gap 48 is thus defined between the acoustic surface 34 and the patient's skin 36, which can be filled with an ultrasonic gel 84 or other acoustically transparent substance to improve imaging, in one embodiment.

[00052] Because the acoustic surface 34 of the ultrasound probe head 32 is not in direct contact with the patient's skin 36 during probe use, pressure on the skin imposed by the acoustic surface is avoided, which in turn prevents a vessel 50 underneath the probe 12 from being compressed by the probe during use. Instead, any downward force provided by the probe 12 is directed through the spacer elements 40. As such, the vessel 50 below the acoustic surface 34 remains patent and can be accurately imaged. Further, the increased distance between the acoustic surface 34 and the patient's skin 36 provided by the gap 48 moves the focal spot of the probe 12 to a location relatively close below the skin surface, which enables superficial vessels and other objects residing near the skin surface to be brought more closely to the focal point of the probe and be sharply imaged.

[00053] Note that the gap 48 shown in FIGS. 1A-2 is bounded during probe use by the acoustic surface 34, the skin 36, and the spacer elements 40. As such, the gap 48 remains open below the front and rear faces 33A, 33B of the probe 12. Note that additional spacers could be employed to further define the gap 48, if desired.

[00054] Reference is now made to FIG. 3 in describing one embodiment, wherein a sheath 52 is placed over the probe 12 to provide a sterile field about the probe. The sheath 52 can be disposed about the probe 12 such that a relatively close fit is defined between the sheath and the side faces 33C and front/rear faces 33A, 33B of the probe so that the ultrasound gel 84 can be included in and confined within the gap 48 by the sheath and the spacer elements 40. Note that sheaths or barriers of many different styles or configurations may be used.

[00055] FIGS. 4A and 4B show example surface configurations for the acoustic surface 34. In FIG. 4A, the acoustic surface 34 is flat as to be substantially parallel with the patient's skin 36 during probe use. In FIG. 4B, the acoustic surface 34 defines a concave shape with respect to the skin 36. This configuration can assist in trapping a volume of ultrasound gel within the gap 48. Of course, other acoustic surface configurations can be employed.

[00056] FIG. 5 gives one example of a possible configuration for the contact surface 42 of the spacer element 40, wherein the contact surface defines a convex shape for engagement with the patient's skin or other tissue surface. Note this is in contrast to the relatively flat contact surface 42 shown in FIGS. 4A and 4B, for instance. Other spacer contact surface shapes can be employed, including straight, rounded, angled, etc.

[00057] FIG. 6 shows that a height “H” of each spacer element 40 can be defined according to a particular need or application in order to define a particular separation between the acoustic surface 34 and the patient’s skin 36 during use of the probe 12. Note that in one embodiment, the spacer elements are integrally formed with the probe housing. In another embodiment, the spacer elements are removably attached to the probe. The spacer elements can include materials similar to or different from those materials included in the probe housing.

[00058] Reference is now made to FIGS. 7 and 8, wherein FIG. 7 shows that in one embodiment the spacer elements 40 can be configured to extend longitudinally a distance “E” past the side surfaces 33C of the probe 12. In FIG. 8, each of the spacer elements 40 is inset a distance “I” from the probe side surfaces 33C.

[00059] FIGS. 9A and 9B depict yet another possible spacer element configuration according to one embodiment, wherein each spacer element 40 is included at an end of an extension arm 48 that extends from a corresponding one of the front and rear faces 33A, 33B of the probe 12. Such a configuration may be useful, for instance, in advancing the probe 12 along the patient skin 36 in a direction parallel to the longitudinal length of the acoustic surface 34. These and other spacer configurations are therefore contemplated as residing with the spirit of the present disclosure.

[00060] FIG. 10 shows a height-adjustable spacer element 40 so as to allow variation in the set-off distance of the acoustic surface 34 from the skin 36. In the illustrated embodiment, a bracket 60 that slidably receives the spacer element 40 is included on the side face 33C of the probe 12 and includes a depression or hole 62. Corresponding protuberances 64 are included on the spacer element 40 and are configured to be selectively received into the hole 62 so as to removably lock the spacer element in place at a specified height. The protuberances 64 are distributed along the length of the spacer element 40 such that one of multiple spacer heights may be selected. A similarly adjustable spacer element is included on the opposite side face of the probe 12. Of course, other adjustable spacer element configurations can be included on the probe in addition to that explicitly described here.

[00061] FIG. 11 shows details of yet another embodiment, wherein the spacer elements 40 are included on a cap 70 that is removably attachable to the probe head 32. In the present embodiment, the cap is snapped on to the probe head 32 via an interference fit, but in other

embodiments other attachment schemes can be employed, including inter-engaging surfaces on the probe and cap, for example. A sheath 72 is attached to the cap 70 so as to provide a sterile barrier for the ultrasound probe 10. In one embodiment the cap 70 and sheath 72 are disposable.

[00062] It should be appreciated that the number, size, height, shape, etc., of the spacer elements can vary from what is explicitly described herein. For instance, one, three, or more spacers can be included. Or the relative heights of the spacers can differ one from another so as to produce an angled probe-to-skin configuration. The probe can include one of many different shapes, designs, etc. These and other modifications are thus considered part of the present disclosure.

[00063] FIG. 12 depicts details of a spacer component 78 configured for attachment to the probe head 32, as shown in FIG. 13A, according to one embodiment. The spacer component 78 includes a body of compliant material, such as a hydrogel, in one embodiment, which generally maintains its intended shape when deforming forces are absent. The compliant material in one embodiment can include AQUAFLEX<sup>®</sup> ultrasound gel from Parker Laboratories, Inc., Fairfield, New Jersey. The spacer component 78 further defines spacer elements 80 on each longitudinal end thereof, with a concavity 82 defined between the spacer elements. It is appreciated that other suitable materials can be employed for the compliant material of the spacer component, including acoustically transparent, sufficiently solid materials such as soft silicone, rubber, etc. In one embodiment, the compliant material is thermoformable, sterilizable, and shelf stable for at least one year.

[00064] As shown in FIGS. 13A-13C, the spacer component 78 due to its compliant nature can deform so as to conform to the shape of the surface of the patient's skin 36 during use of the probe 12. For example, the probe 12 including the spacer component 78 can be placed on a patient's arm. So positioned, the spacers 80 of the spacer component 78 can deform as needed as to match the cross sectional curvature of the arm surface and maintain contact with the skin 36 thereof. FIGS. 13B and 13C show such deformation of the spacer component 78 for relatively larger arms. Thus, the spacer component 78 provides an acoustic path between the acoustic surface and the skin surface without need of a flowable ultrasound gel. It is appreciated that the spacer component can be used in connection with imaging other portions of the patient's body and that the spacer component can define other shapes for contacting

differently shaped body portions. Further, in one embodiment, an ultrasound gel can be included between the spacer component and the skin, such as in the concavity thereof.

[00065] FIG. 14 depicts a spacer component 90 according to another embodiment, including a flexible casing 92 that can operably attach to the probe head 32, as shown. The casing 92 includes arms 92A that contain a compliant insert 94, such as hydrogel in one embodiment. As shown in FIGS. 15A and 15B, the spacer component 90 is positioned on the probe head 32 so as to provide both spacing and an acoustic path between the acoustic surface 34 and the surface of the skin 36 or other tissue surface such that flowable ultrasound gel is not needed. So configured, the insert 94 thereof defines a contact surface 96 for contacting the surface of the skin 36 during ultrasound probe use. In one embodiment, the arms 92A of the casing 92 can be pressed inward to modify the shape of the contact surface 96. For instance, FIG. 15A shows that the contact surface 96 of the insert 94 defines a relatively shallow concavity 98 when the arms 92A of the casing 92 are allowed to flex outward. When the arms 92A are pressed inward as in FIG. 15B, however, the insert 94 is compressed by the arms and the concavity 98 of the contact surface 96 becomes relatively more pronounced. Such a configuration of the contact surface 96 may be desirable to stabilize a position of the subcutaneous vessel while preventing its collapse. The arms 92A can be biased to restore themselves to a given position when not being pressed by a user.

[00066] FIG. 16 shows details of a probe cap 110 for use with the probe 12 according to one embodiment. The cap 110 is configured to receive therein the head 32 of the probe 12 and to provide a spacer component 118 for providing desired spacing between the acoustic surface 34 of the probe head 32 and the skin 36.

[00067] As shown in FIGS. 17A-17D, the cap 110 defines a cavity 112 that is sized to receive therein the head 32 of the probe 12. An engagement feature 114 is included with the cap 110 to releasably and mechanically attach the cap to the probe 12, though it is appreciated that various designs can be employed to accomplish the same functionality. The cap 110 further includes a needle guide base 116 on which a detachable needle guide can be placed so as to assist a clinician in placing a needle through the skin 36 after a vessel has been located through use of the ultrasound system 10 (FIG. 1A).

[00068] With continuing reference to FIGS. 17A-17D, reference is made to FIGS. 18A and 18B, which depict various details of the spacer component 118, which is disposed in a

hole 130 defined in the cap 110, best seen in FIGS. 17A and 17C. As shown, the spacer component 118 includes a skin contact surface 126 that defines two spacer elements 120 and a concavity 122 disposed therebetween. The spacer component includes 118 a compliant material, such as hydrogel in one embodiment, though it is appreciated that other suitable materials can also be employed. The spacer component 118 thus requires no use of flowable ultrasound gel to be applied to the skin 36 in order to provide an acoustic path between the acoustic surface 134 and the patient's skin. The spacer component 118 further defines a lip 128 about a perimeter thereof to assist in its retention within the hole 130 of the cap 110, as seen in FIG. 18B. As shown, in the present embodiment the lip 128 is shaped so as to be sandwiched between the cap 110 and probe head 32, thus preventing its unintended removal from the cap.

[00069] FIG. 19 shows that in the present embodiment the acoustic surface 134 of the probe head 32 defines a convex shape. Correspondingly, FIG. 20 shows that a probe contact surface 136 of the compliant spacer component 118 also defines a convex surface. FIG. 21 shows that when the probe head 32 is received into the cavity 112 of the cap 110, the convexly shaped probe contact surface 136 of the spacer component 118 deformably engages the convexly shaped acoustic surface 134 of the probe head 32 so as to ensure adequate contact therebetween and to provide a suitable acoustic path through the spacer component. Of course, other complementary shapes can be employed on the acoustic surface and probe contact surface of the spacer component.

[00070] FIG. 22 shows another view of the engagement between the probe head 32 and the cap 110, according to the present embodiment. A recess 138 is included on the cap 110 to receive therein an orientation nub 140 on the probe head 32, which nub provides a landmark for orienting an ultrasound image on the display 30 (FIG. 1A) with the orientation of the probe 12 as held by the clinician. FIG. 23 shows the cap 110, including the spacer component 118, removably attached to the probe 12. Note that in one embodiment the cap provides a sterile barrier for the probe head, and is disposable.

[00071] FIGS. 24A-24C depict the probe cap 110 and the concavely-shaped, compliant spacer component 118 according to one embodiment, together with the ultrasound probe 12. As shown, a suitably shaped cover 148 is also included for covering the spacer component 118 to prevent contamination thereof and to prevent the spacer component from drying out

before use. When use of the probe cap is desired the cover 148, which is fit to the probe cap 110 via a friction or other suitable fit, can be simply removed and discarded by the clinician.

[00072] As best seen in FIG. 24C, the cap 110 includes in the present embodiment a bracket 144 to which a needle guide can be removably attached so as to enable guidance of a needle toward a desired vessel imaged by the ultrasound probe 12. Further details regarding one non-limiting example of a needle guide that can be attached to the bracket 144 can be found, for instance, in U.S. Provisional Application No. 61/426,297, filed December 22, 2010, and entitled "Selectable Angle Needle Guide," which is incorporated herein by reference in its entirety. Note that the needle guide and bracket can vary from what is shown and described herein.

[00073] The discussion below discusses yet other structures for enhancing use of an ultrasonic probe in connection with placement of catheters and other medical devices in the body of a patient. Indeed, the embodiments disclosed herein facilitate ease of use when ultrasonically imaging portions of the patient body in preparation for device placement therein. Examples of such placement scenarios include the insertion by a clinician of a needle, PICC catheter, PIV catheter, mid-line catheter, etc. into the patient body via a transcutaneous insertion site.

[00074] FIGS. 25A-25D show details of a probe cap 160 according to one embodiment, which defines a cavity 162 for receiving therein the head 32 of the probe 12 and an engagement feature 164 for enabling removable engagement of the cap to the probe head. A fixture 166 is included on the side of the cap 160 and is configured for removably receiving thereon a needle guide 192. In another embodiment, this and other needle guides disclosed herein can be permanently attached to the cap. Note that, though not shown here, a spacer component similar to those shown and described in connection with FIGS. 24A-24C is disposed in the aperture 130 of the cap 160 to provide an acoustic pathway from the probe head 32 to the patient's skin.

[00075] As best seen in FIG. 25D, the needle guide 192 defines a channel 194 into which a portion of a cannula of a needle to be inserted into the patient can be temporarily received. Note that the size of the channel can accommodate needle cannulas of various sizes/diameters, as here, or can be configured to accept needles of a predetermined size. An abutment surface 196 is included at a distal end of the channel 194 about which the needle

can pivot so as to continuously define differing angles of attack with respect to the patient's skin during needle insertion procedures. As such, the needle guide 192 is capable of guiding the needle at any one of a variety of angles of attack toward the patient's skin while maintaining alignment of the needle with the subcutaneous vessel being imaged by the probe 12.

[00076] Note that the probe cap 160 and other caps discussed herein can be configured to mate with the head portion of the ultrasound probe in a variety of ways, including friction fit, clip-pocket engagement, adhesively, hook-and-loop, etc. The cap portion of the probe cap can also vary in design from what is shown and described herein.

[00077] The cap 160 further includes a stabilization arm 200 extending from a distal portion of the cap body. The stabilization arm 200 is configured to rest against the skin of the patient when the cap-equipped probe is held vertically and placed against the patient's skin during ultrasound imaging procedures, thus stabilizing the probe in the vertical position. Moreover, the stabilization arm 200 can assist in securing the cap-equipped probe to the patient's skin via the use of a cord or elastic band, for instance, that is extended about the patient's arm and over the stabilization arm, thus maintaining the ultrasound probe in the upright position without manual contact by the clinician during use and providing more freedom to the clinician during the imaging procedure. A hole 202 is also defined in the stabilization arm 200 in one embodiment to enable the clinician to press the patient's skin therethrough in order to locate/occlude a subcutaneous vessel. The area proximate the perimeter of the hole 202 is contoured in the present embodiment to assist with finger placement by the clinician. FIGS. 26A and 26B show various details of a probe cap 210 according to another embodiment, including a cavity 212 defined by the cap body that is configured to supportably receive the head 32 of the ultrasound probe 12 therein via snap-fit or other suitable modality. A fixture 216 for receiving thereon a needle guide is also included on the cap body.

[00078] A compliant membrane 218 defining a lip 218A about its perimeter is included for attachment to the cap body. Specifically, the cap body defines a ridge 219 about an aperture 230 at the distal end of the body. The lip 218A of the membrane 218 is configured to resiliently attach to the ridge 219 so as to join the membrane to the cap body and cover the ultrasound transducer of the probe head 32 when the cap 210 is attached to the probe 12. The membrane 218 thus provides an acoustic pathway between the transducer and the patient's

skin. Note that ultrasound gel on the patient's skin may, but need not, be used with the cap 210 during ultrasound imaging. Note also that the membrane 218 in one embodiment includes silicone, though other suitable, compliant materials can also be employed.

[00079] In greater detail, the ridge 219 includes a concavely shaped concavity 222, as best seen in FIGS. 26A and 27, such that it defines two standoffs, or spacers 220, on either end. The compliant nature of the membrane 218 enables it to deform to the concavity 222 of the ridge 219 when the membrane is placed against the patient's skin during ultrasound procedures. Thus, the membrane 218 can conform to the skin 36 of the patient during ultrasound imaging so as to enable imaging of subcutaneous structures, such as a superficial vessel 50 seen in FIG. 27, without providing undesired compressive forces thereon.

[00080] FIGS. 28A and 28B depict a probe cap 260 according to one embodiment, wherein the body of the cap defines a cavity 262 and a fixture 266 for receiving thereon a needle guide. An ultrasonically transparent membrane 268 is included proximate an aperture 280 at a distal end of the cap body to cover the transducer of the head of an ultrasound probe inserted therein. An ultrasonically transmissive medium, such as ultrasound gel 269, can be placed on an interior surface of the membrane 268 to ensure acoustic coupling between the transducer and the skin of the patient. As with other cap embodiments described herein the probe cap 260 can be configured as a sterile cap to provide sterility or isolation for the ultrasound probe. Spacers 270 can also be included on either side of the membrane 268 to prevent compression by the cap 260 of superficial vessels when the cap 260 is placed against the skin. Note that ultrasound gel can also be placed between the membrane 268 and the patient's skin to improve signal transfer, if desired.

[00081] FIGS. 29A-29D depict details of a probe cap assembly 310 according to another embodiment, wherein the assembly includes a cap body defining a cavity 312 for receiving therein the head 32 of the ultrasound probe 12, as before. Also as before, an engagement feature 314 is included to secure the cap body to the probe 12.

[00082] The cap body is movable between two parallel rails 350 of a bracket 340. Each rail 350 includes a plurality of slots 352 that align with corresponding slots on the opposing rail 350. Tabs 319 included on either longitudinal end of the cap body are configured to be selectively received into corresponding opposed slots 352 of the rails 350, as shown in FIGS. 29A-29D. In the illustrated embodiment, the cap body is selectively repositionable along the

bracket rails 350 via manual movement by lifting the cap body so as to remove the tabs 319 from the corresponding slots 352, repositioning the cap body as desired with respect to the bracket rail slots, then inserting the tabs into the selected slots. In other embodiments, it is appreciated that other modalities for moving the cap body relative to the bracket are possible, including sliding movement, gear-driven movement, etc.

[00083] As best seen in FIGS. 29B-29D, a needle guide 342 is included in the bracket to guide a needle into the patient's body when the probe cap assembly 310 is placed on the patient's skin. An observation hole 346 is also included on the bracket 340 so as to enable a clinician inserting the needle to observe blood flashback upon the needle accessing the subcutaneous vessel.

[00084] Note that the needle guide 342 in the present embodiment is disposed at a fixed angle with respect to the bracket 340 and that the cap body is movable along the bracket with respect to the needle guide. This arrangement thus enables subcutaneous tissue to be imaged, by the ultrasound probe disposed in the cap body, at differing discrete distances from the needle guide 342. Further, this arrangement enables a needle inserted through the needle guide 342 to access an ultrasonically imaged vessel or other target at any one of a plurality of depths below the skin without the need for adjusting the angle of attack of the needle.

[00085] In greater detail, the probe 12 while disposed in the cap body of the probe cap assembly 310 can ultrasonically image a subcutaneous vessel within the patient and determine the depth below the skin surface at which the vessel resides. One or more of the slots 352 are marked with a number, indicating the depth below the skin at which a needle inserted into the patient through the needle guide 342 will intercept the subcutaneous vessel. Thus, the bracket 340 can be adjusted until the tabs 319 thereof are disposed in the slots 352 on either rail 350 corresponding to the depth of the imaged vessel. When the needle is inserted into the patient's skin through the needle guide 342, it can be advanced until it intercepts and accesses the imaged vessel at the determined depth, as desired. As such, it is appreciated that the probe cap assembly 310 can assist with needle access of an ultrasonically imaged vessel through a fixed-angle needle guide regardless of the depth of the vessel, thus obviating the need for an adjustable angle needle guide in the present embodiment. Note that the depth measurements of the bracket can vary from what is shown, but in one embodiment, the depths accessible via the probe cap assembly 310 vary from about 0.3 cm to about 1.5 cm.

[00086] FIGS. 30A and 30B depict a probe cap 360 according to another embodiment, wherein the cap body defines a cavity 362 for receiving therein the head 32 of the ultrasound probe 12 and an engagement feature 364 to secure the cap body to the probe 12. A stabilization arm 365 extends from the cap body so as to enable the cap 360 (and the probe 12 received therein) to be secured to the patient via a band wrapped around the stabilization arm and the arm of the patient, for instance.

[00087] As shown, the probe cap 360 further includes a deflector portion 390 for deflecting an ultrasound signal both emanating from and travelling to the transducer of the ultrasound probe 12. The deflector portion 390 is formed as part of the probe cap 360 and defines a channel 392 and an aperture 396 through which ultrasound signals can pass. The deflector portion 390 further includes a deflecting surface 394 disposed in the channel 392. In the present embodiment the deflecting surface 394 is disposed at an angle of about 45 degrees with respect to the transducer surface of the probe head 32 so as to deflect ultrasound signals emanating therefrom through an angle of about 90 degrees, though the deflecting surface can be positioned in other embodiments at other angles so as to produce different resulting angles of signal deflection with respect to the probe transducer.

[00088] FIG. 31 shows the probe cap 360 positioned against the skin 356 of a patient such that signals emanating from the transducer of the probe head 32 travel through the channel 392, are deflected by the deflecting surface 394, and are directed downward into the body of the patient. Ultrasound signals reflected by an imaged target within the body and received into the channel 392 are also similarly deflected by the deflecting surface 394 toward the probe head 32 for receipt by the transducer. The deflecting surface 394 can include any suitable material having a suitable density so as to reflect the ultrasonic signals travelling through the channel 392. In one embodiment, the deflecting surface includes a plastic material. Also, in one embodiment, the channel 392 is at least partially filled with an ultrasonically transmissive medium, such as an ultrasound gel. In another embodiment, a hydrogel-based spacer component can be disposed in the channel 392, as in previous embodiments. In yet another embodiment, the deflector portion can be integrated into the probe head itself, without the presence of a probe cap. Use of the deflecting probe cap 360 enables the probe 12 to be positioned parallel to the skin 36 of the patient, thus eliminating the need for the clinician to hold the probe upright during use.

[00089] FIG. 32 shows that the deflecting probe cap 360 in one embodiment can be included as part of an assembly similar to that shown in FIGS. 29A-29D, wherein the cap body is selectively movable between two rails 410 of a bracket 400. The rails 410 each include corresponding slots 412 for receipt of tabs 369 included on the cap body so as to position the probe cap at one of a plurality of possible distances from a needle guide 402 included on the bracket 400. As before, an observation hole 406 is included proximate the needle guide 402. As described further above in connection with FIGS. 29A-29D, the assembly shown in FIG. 32 enables vessels at a variety of subcutaneous depths to be ultrasonically imaged and accessed by a needle disposed in the fixed-angle needle guide 402 by moving the bracket 400 with respect to the probe cap 360 such that the needle intercepts the imaged vessel at the intended depth.

[00090] FIGS. 33A and 33B depict the deflecting probe cap 360 according to one embodiment, wherein the deflector portion 390 is hingedly connected to the remainder portion of the cap body via a hinge component 420, including a mechanical or living hinge for instance. So configured, the deflector portion can be selectively positioned so as to deflect ultrasound signals along a deflected signal path 424A (FIG. 33A), or rotated out of the ultrasound signal path (FIG. 33B) so as to enable the ultrasound signals to travel along an undeflected signal path 424B. A latch 426 or other suitable modality can be included to selectively secure the deflector portion 390 in place. Note that in one embodiment a deflecting probe cap can be adjustable such that deflection of the ultrasound signal can be achieved through a variety of angles.

[00091] FIG. 34 shows a needle guide 450 according to one embodiment that can be employed with one or more of the probe caps described herein, such as the probe cap 460 shown in FIG. 35B, or can be attached directly to the ultrasound probe. As shown, the needle guide 450 includes a curved, V-shaped open channel 454 that centers a needle therein yet enables the clinician to continuously adjust the angle of attack  $\theta$  for the needle at the insertion site during needle insertion, as shown in FIG. 35A. Note that the shape of the channel can vary from what is shown and described.

[00092] Embodiments of the invention may be embodied in other specific forms without departing from the spirit of the present disclosure. The described embodiments are to be considered in all respects only as illustrative, not restrictive. The scope of the embodiments is, therefore, indicated by the appended claims rather than by the foregoing description. All

changes that come within the meaning and range of equivalency of the claims are to be embraced within their scope.

What is claimed is:

**CLAIMS**

1. A cap for use with an ultrasound probe, comprising:  
a body defining a cavity into which a head portion of the probe is removably received;  
a stabilization arm extending from the cap body for stabilizing the cap against a skin surface of a patient; and  
a needle guide included with the cap.
2. The cap as defined in claim 1, wherein the stabilization arm further defines a hole to enable a clinician to contact the skin of the patient proximate a needle insertion area, a perimeter area proximate the hole being contoured.
3. The cap as defined in claim 1, further including an engagement feature for securing the cap to the ultrasound probe, wherein a corresponding engagement feature is included with the head portion of the ultrasound probe head.
4. The cap as defined in claim 1, wherein the needle guide is removably attachable to a fixture included on the cap body.
5. The cap as defined in claim 1, wherein the needle guide includes a channel in which a portion of a needle can be movably received, the channel including an abutment surface upon which the needle can pivot within the channel so as to selectively alter an angle of attack of the needle with respect to the skin of the patient.
6. The cap as defined in claim 1, wherein a band or strap is used to secure the stabilization arm to the patient so as to support the ultrasound probe against the skin of the patient.

7. A cap for use with an ultrasound probe, comprising:
  - a body defining a cavity into which a head portion of the probe is removably received;
  - an aperture defined at a distal end of the cap body, a portion of a perimeter of the aperture concavely shaped so as to define first and second spacer components; and
  - a membrane shaped to cover the aperture, the membrane being compliant so as to enable the membrane to conform to the concavely shaped aperture perimeter when the membrane is placed against the skin of a patient.
8. The cap as defined in claim 7, wherein the spacer components assist in preventing compression of the skin by the concavely shaped portion of the aperture perimeter when the distal end of the cap is placed against the skin of the patient.
9. The cap as defined in claim 7, wherein the membrane includes a lip that fits about the perimeter of the aperture, wherein the cap includes a fixture to which a needle guide can be removably attached, and wherein the membrane includes silicone.
10. A cap assembly for use with an ultrasound probe, comprising:
  - a cap body defining a cavity into which a head portion of the ultrasound probe is removably received; and
  - a bracket that movably supports the cap body, the bracket including a needle guide, the cap body movable with respect to the bracket so as to enable the distance between the needle guide and the cap body to be selectively varied.
11. The cap assembly as defined in claim 10, wherein the needle guide defines a fixed angle of attack for a needle disposed therein, and wherein selective variation of the distance between the needle guide and the cap body enables interception of a subcutaneous path of the needle with a desired subcutaneous target imaged by the ultrasound probe.
12. The cap assembly as defined in claim 11, wherein the bracket includes demarcations indicating a depth of interception of the needle with the imaged subcutaneous target.

13. The cap assembly as defined in claim 10, wherein the bracket includes first and second rails between which the cap body is movably disposed, the first and second rails including a plurality of aligned slots into which tabs disposed on the cap body can be removably received to position the cap body at a predetermined distance from the needle guide.

14. The cap assembly as defined in claim 10, wherein the cap assembly is placed against a user's skin such that ultrasound signals produced by the ultrasound probe are directed into the patient.

15. The cap assembly as defined in claim 10, wherein the bracket further includes an observation hole proximate the needle guide for observing blood flashback from the needle.

16. A cap for use with an ultrasound probe, comprising:  
a body defining a cavity into which a head portion of the probe is removably received; and  
a deflector portion that redirects an ultrasound signal emitted from the probe through a deflection angle from a first direction to a second direction so as to exit an aperture of the probe cap.

17. The cap as defined in claim 16, wherein the aperture is placed against the skin of a patient such that the ultrasound probe is substantially parallel to the surface of the skin and wherein the cap further includes a needle guide disposed on the deflector portion and a stabilization arm extending from the cap body.

18. The cap as defined in claim 16, wherein the cap is movably attached to a bracket including first and second rails, the bracket including a needle guide.

19. The cap as defined in claim 16, wherein the deflector portion includes a deflecting surface such that the deflection angle is substantially about 90 degrees.

20. The cap as defined in claim 16, wherein the deflector portion is hingedly attached to the cap body so as to be selectively removed from the ultrasound signal path.

21. The cap as defined in claim 16, wherein the deflector portion is removable from the cap body.

22. A needle guide, comprising:  
a curved, open channel that enables an angle of attack of a needle disposed in the channel to be continuously adjusted with respect to a skin surface of a patient.
23. The needle guide as defined in claim 22, wherein the channel is V-shaped so as to center the needle within the channel.

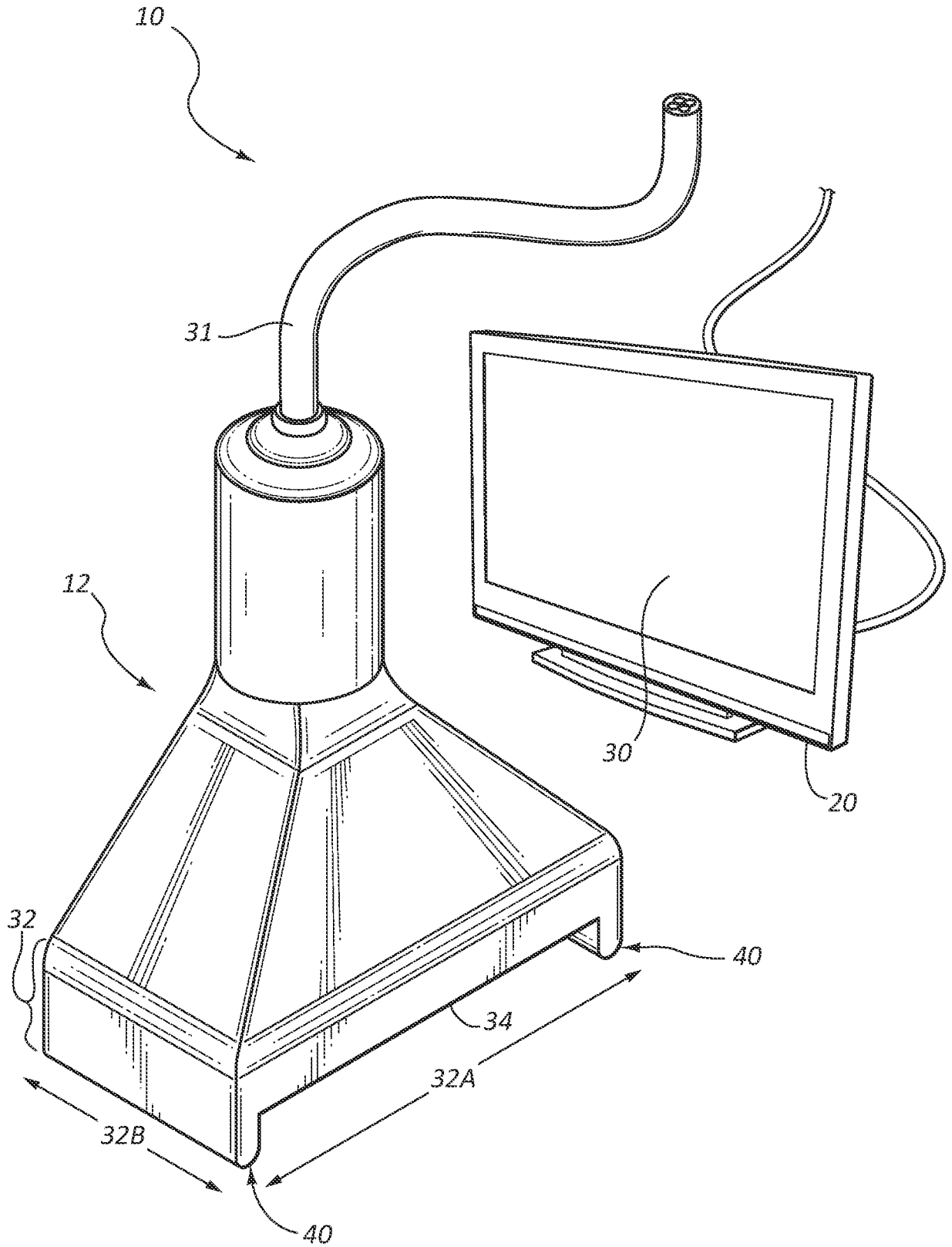
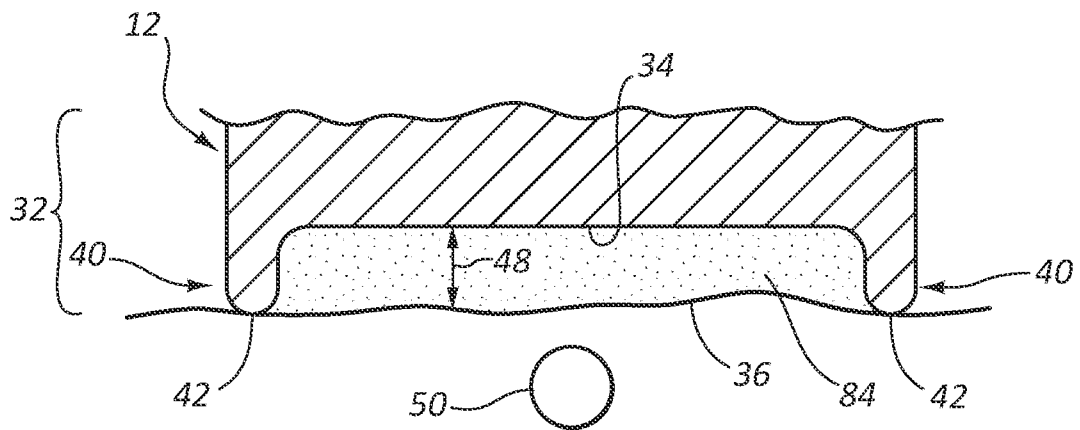
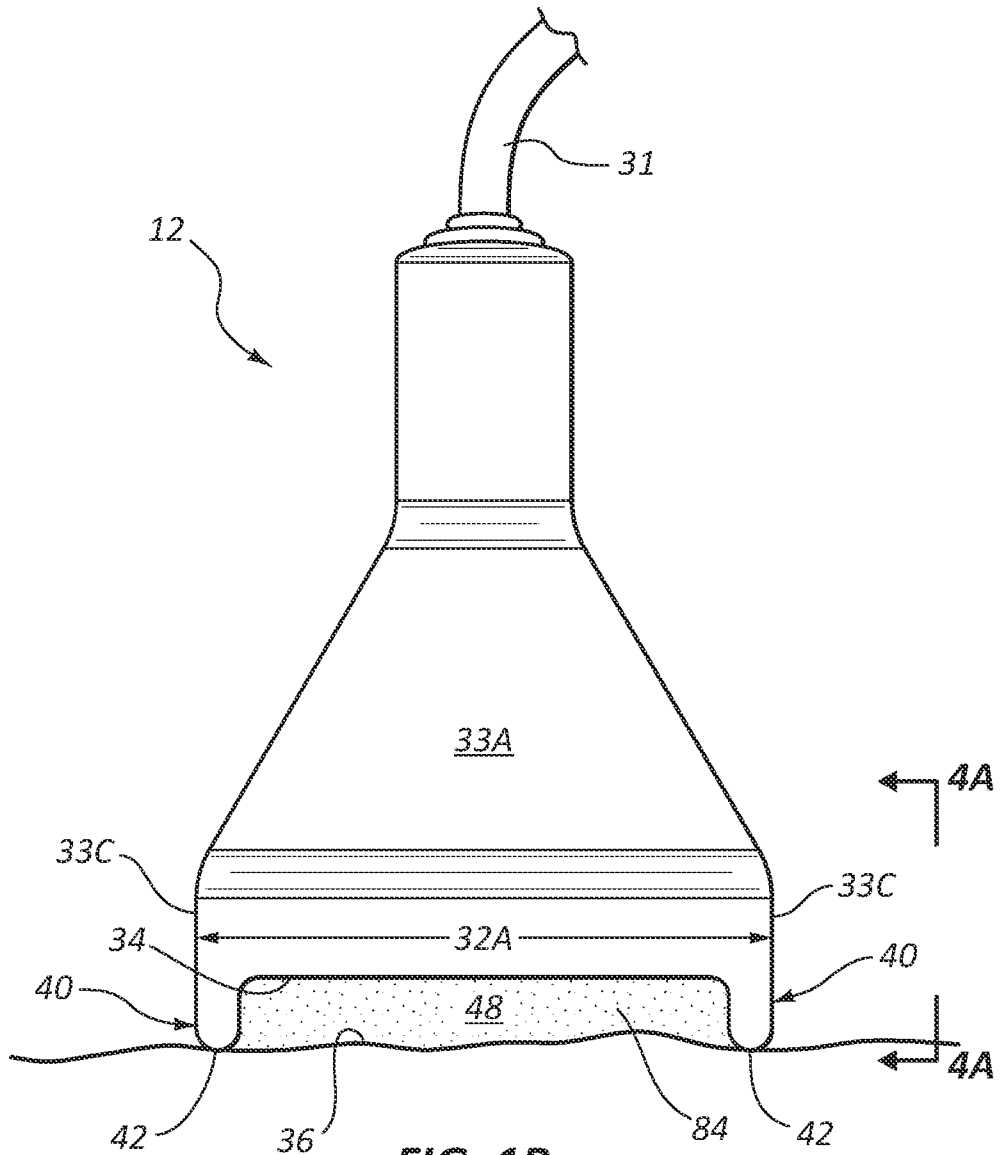


FIG. 1A



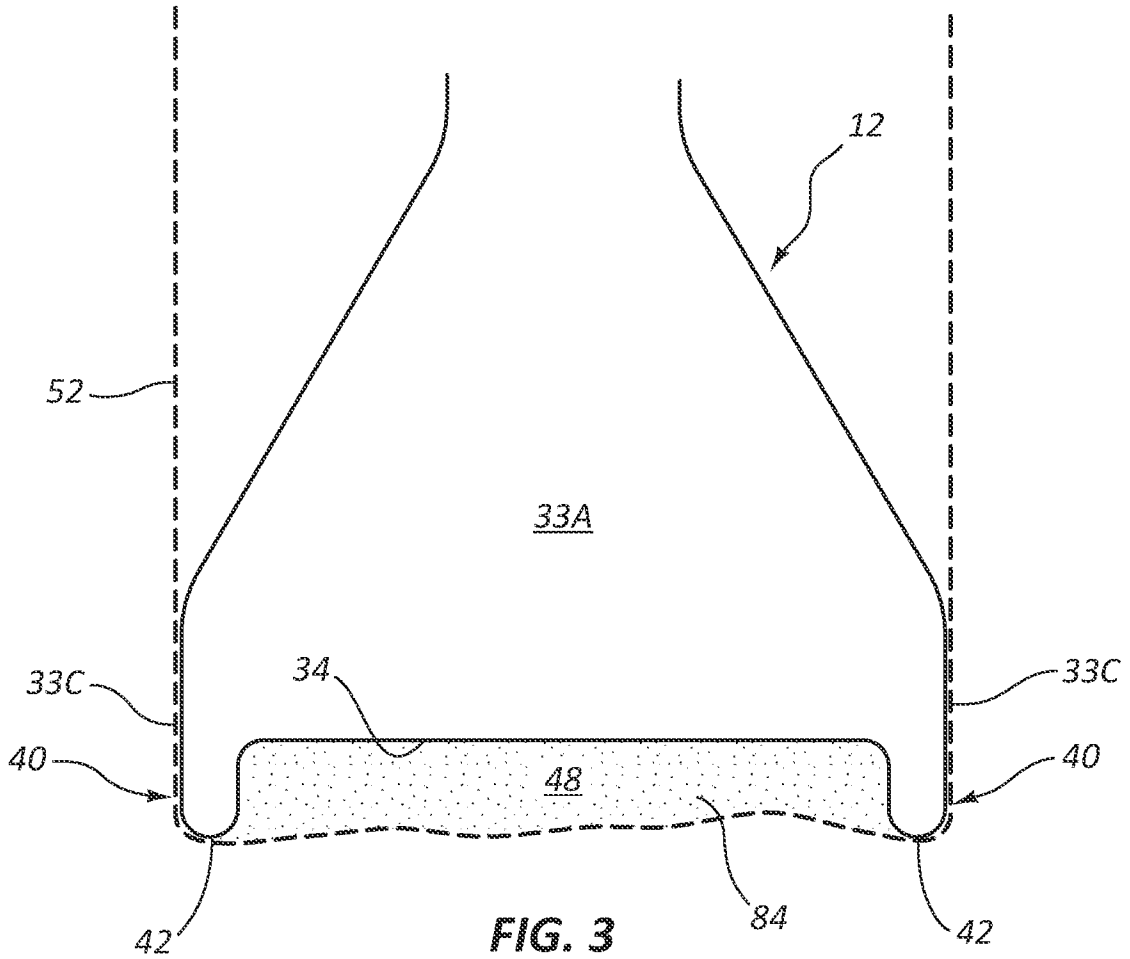


FIG. 3

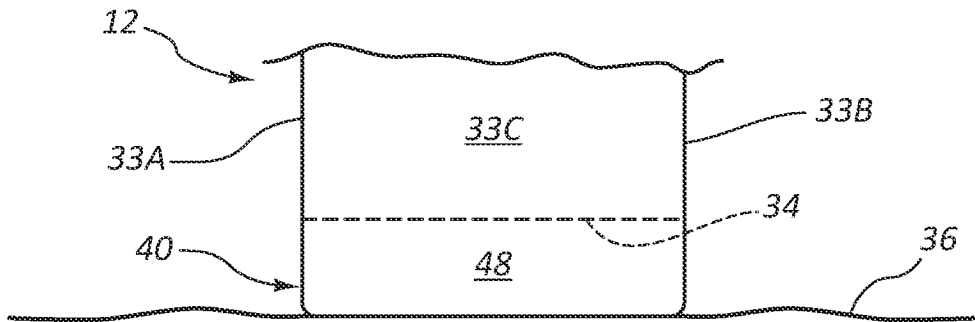


FIG. 4A

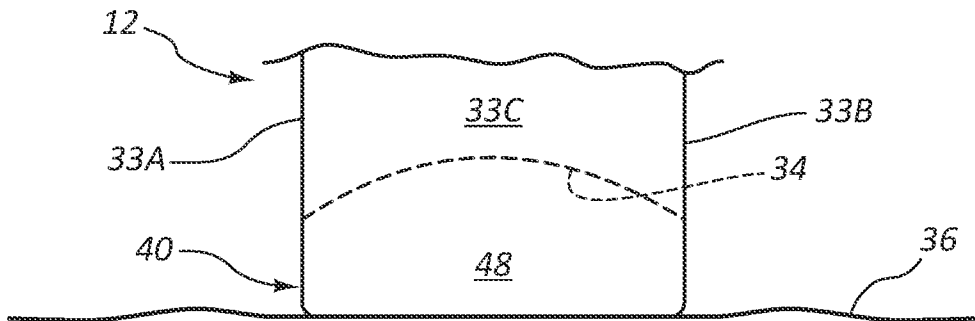


FIG. 4B

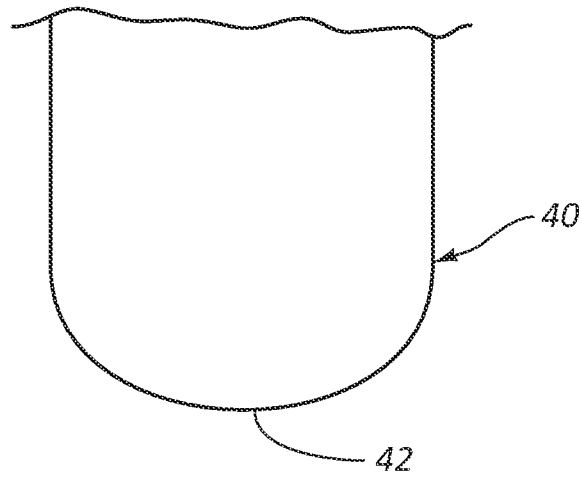


FIG. 5

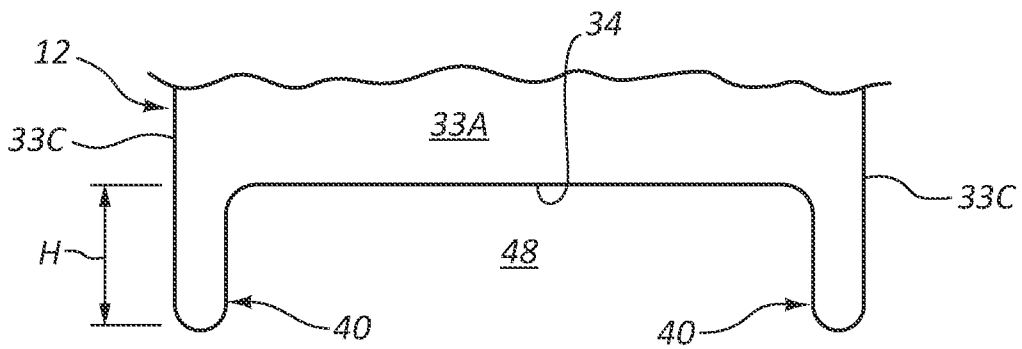


FIG. 6

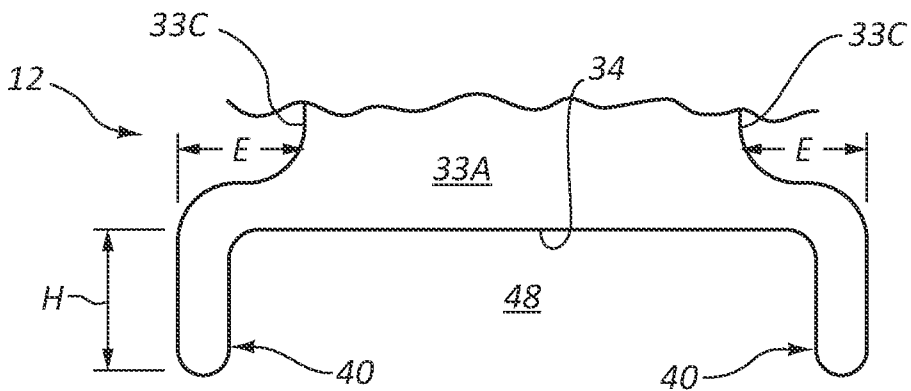
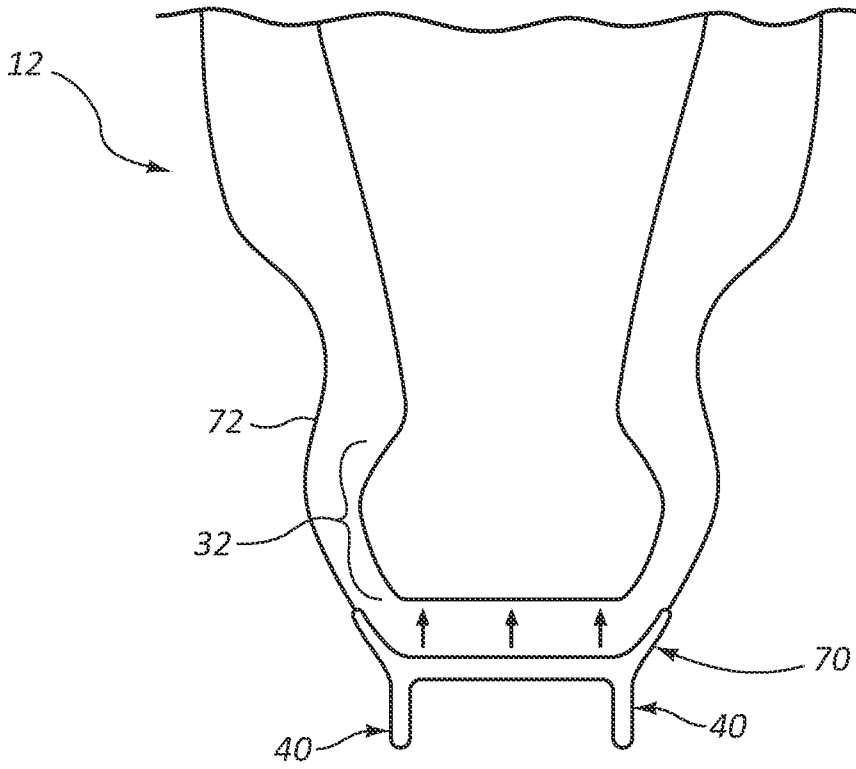


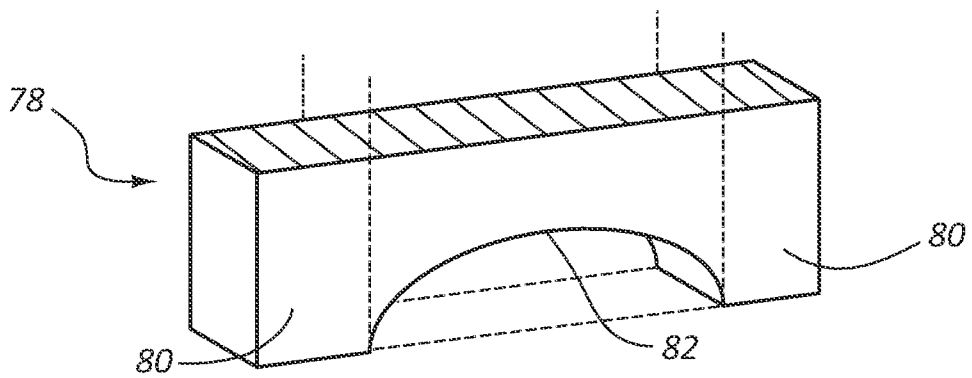
FIG. 7



6/26

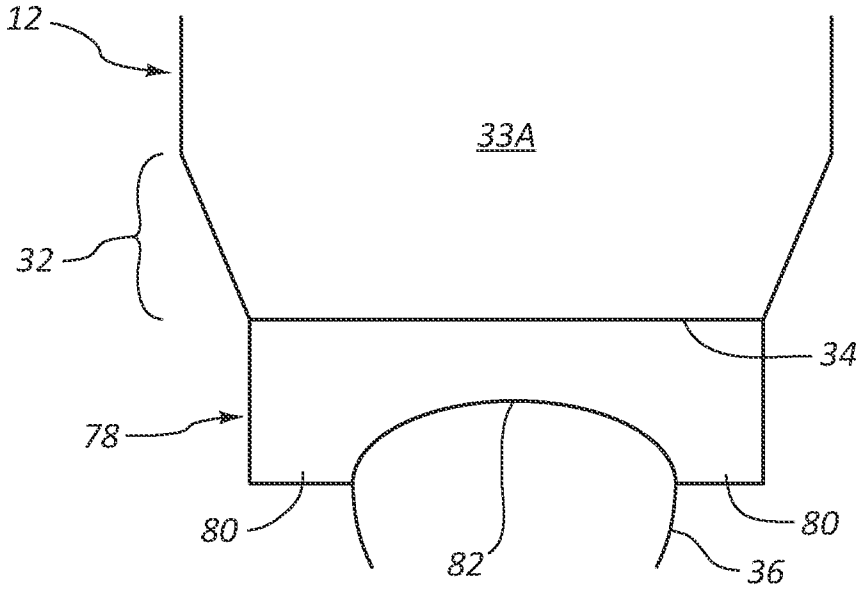


**FIG. 11**

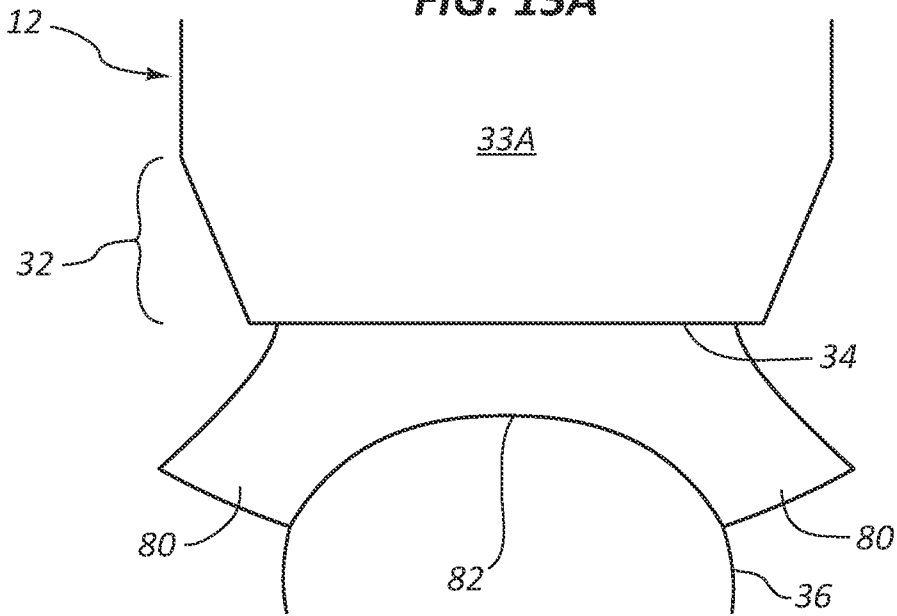


**FIG. 12**

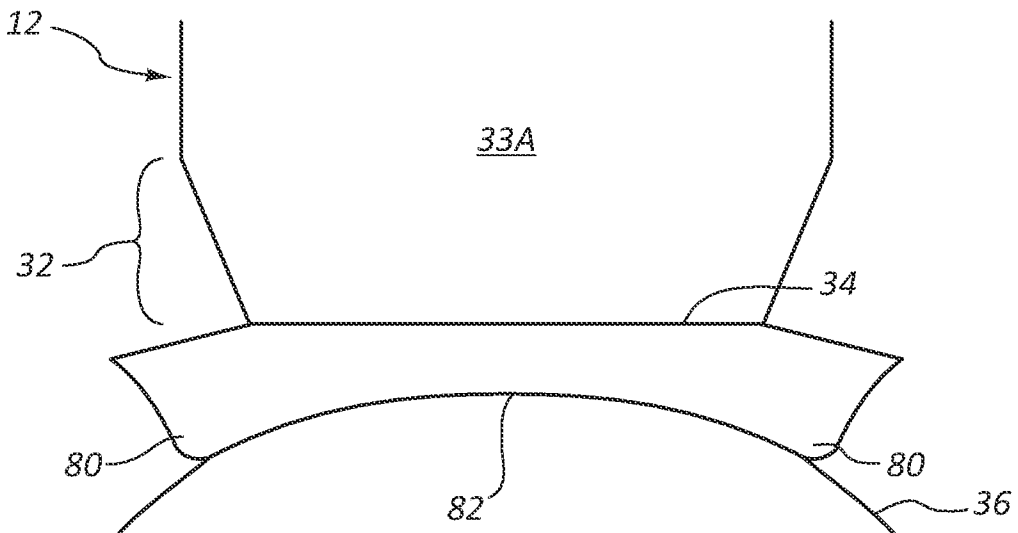
7/26



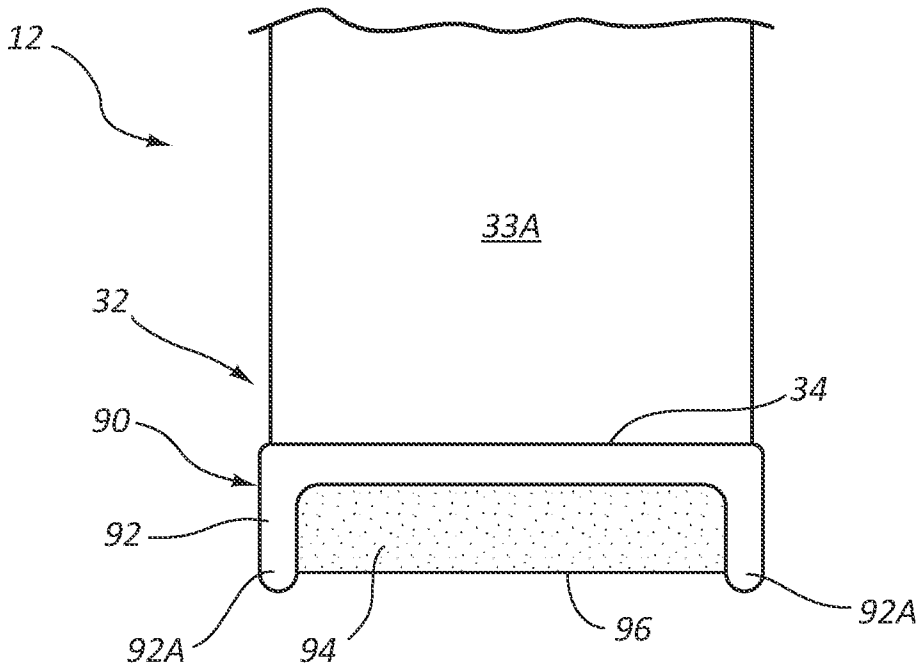
**FIG. 13A**



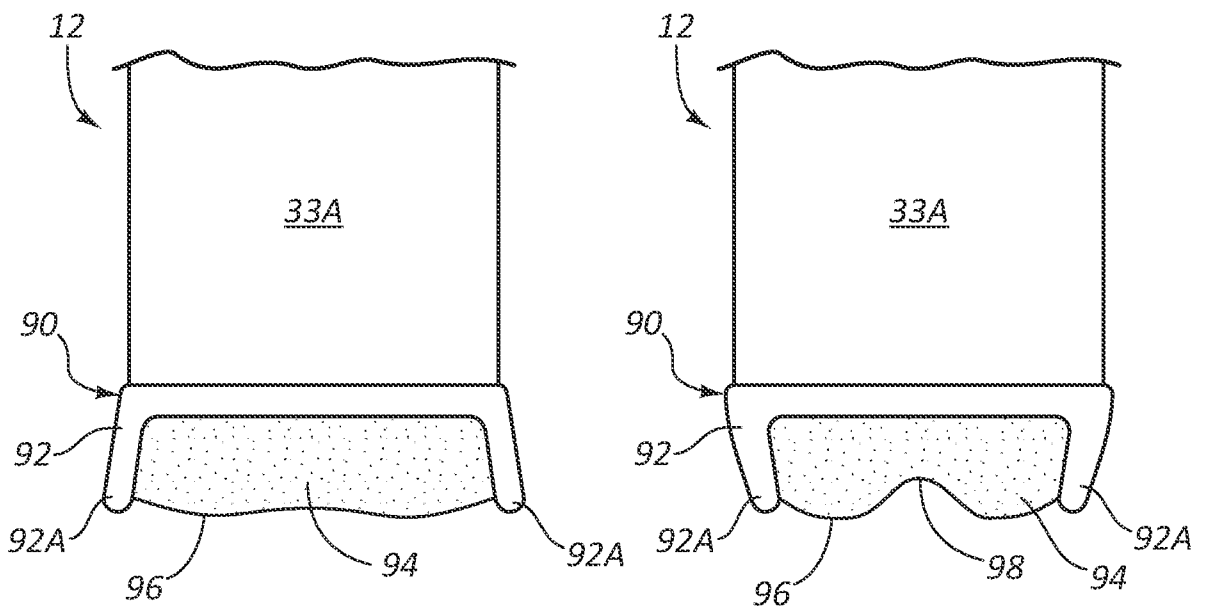
**FIG. 13B**



**FIG. 13C**



**FIG. 14**



**FIG. 15A**

**FIG. 15B**

9/26

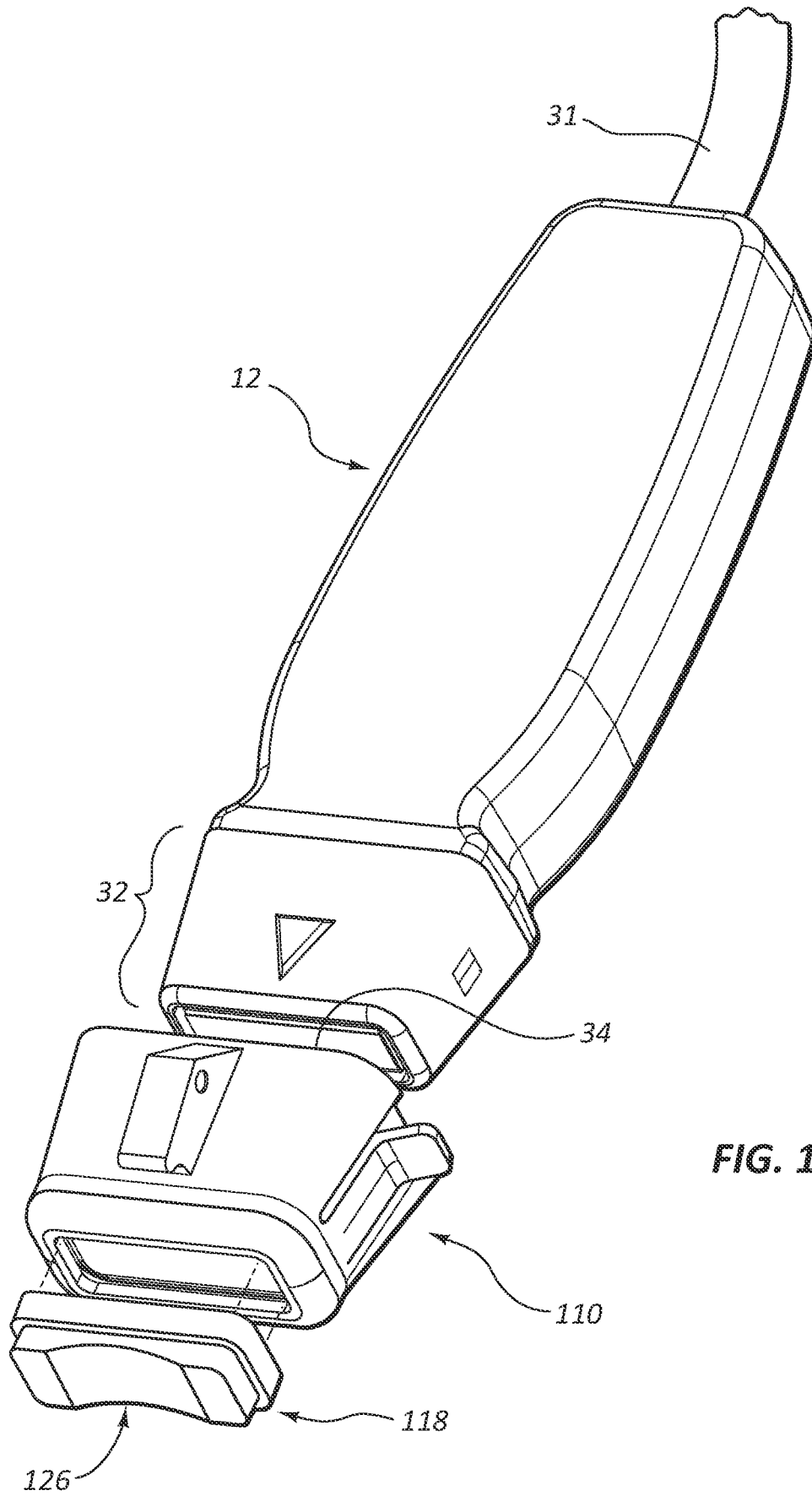


FIG. 16

10/26

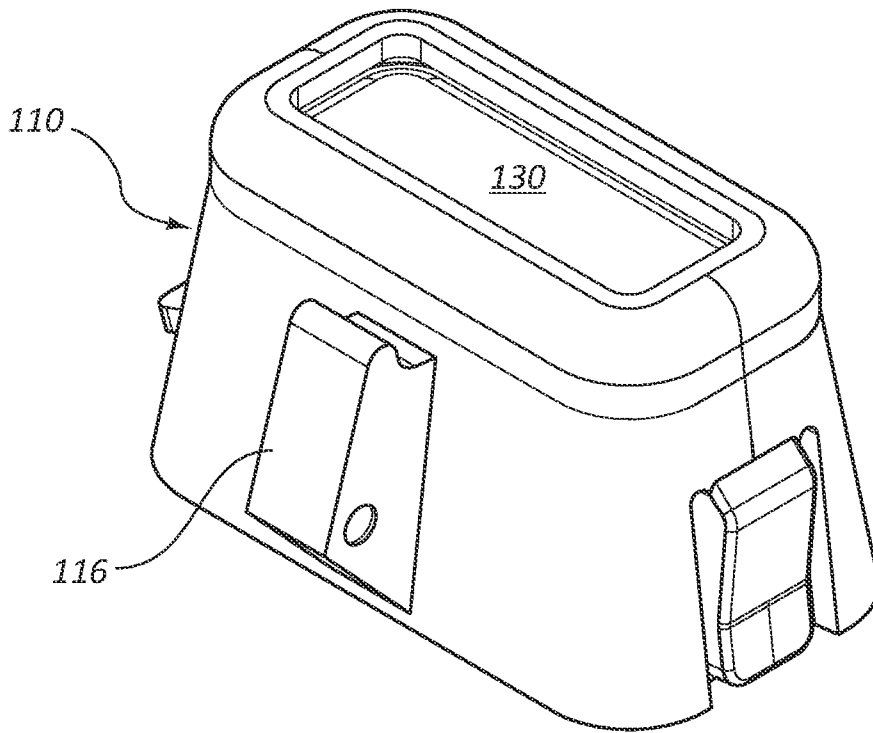


FIG. 17A

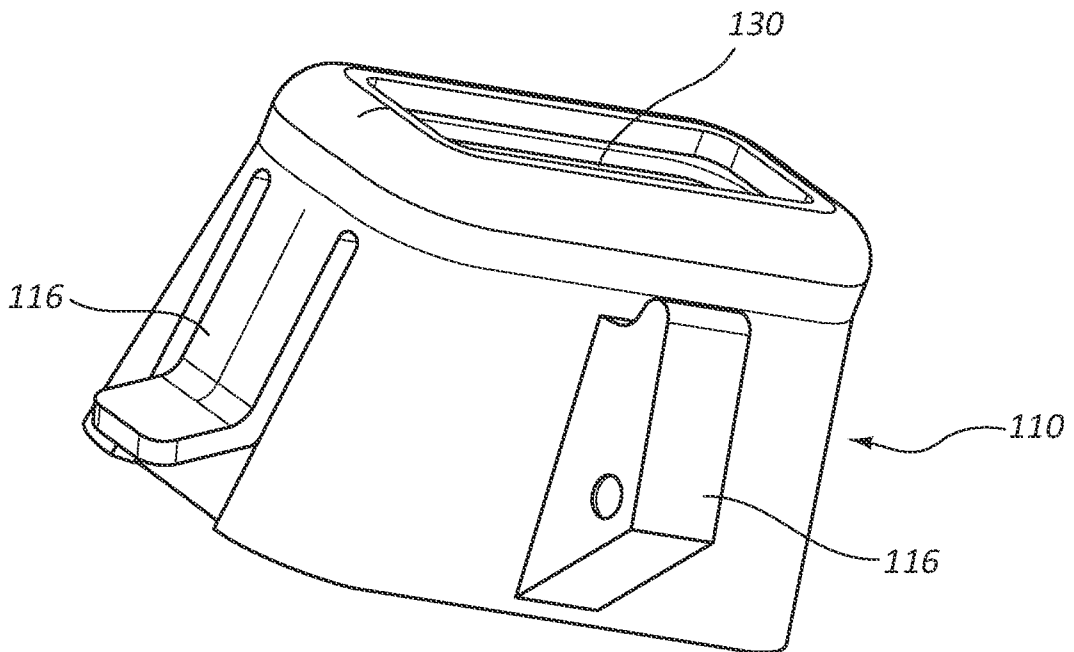


FIG. 17B

11/26

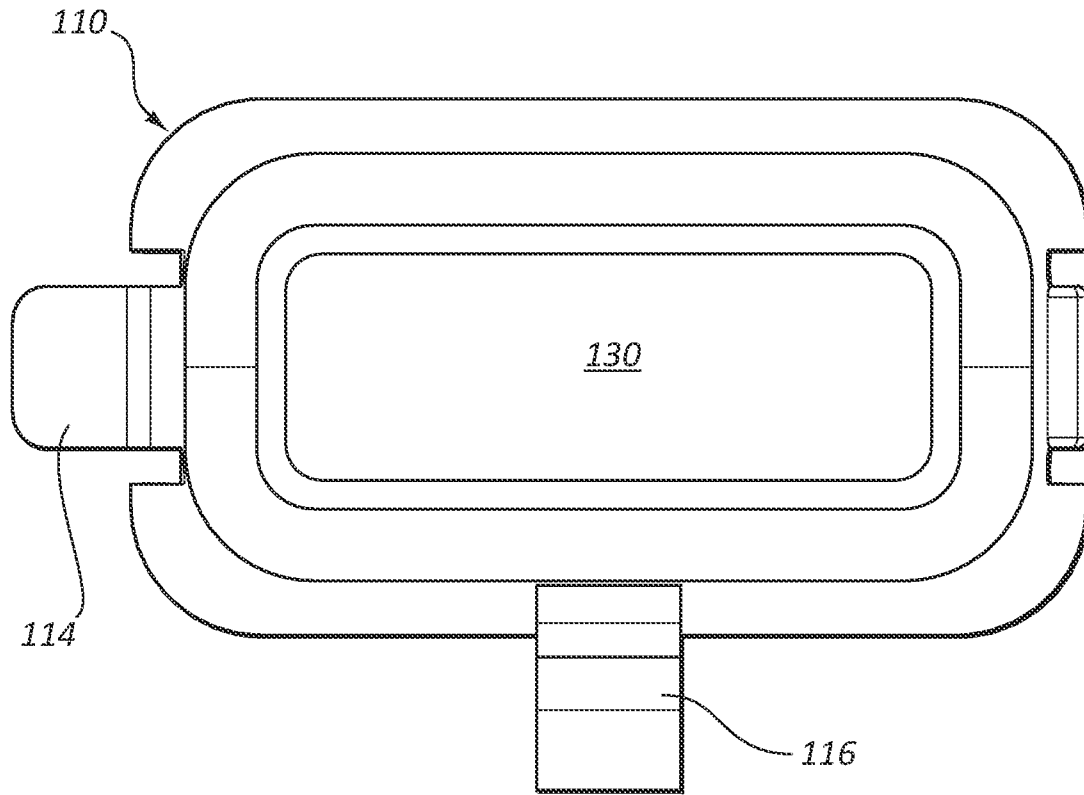


FIG. 17C

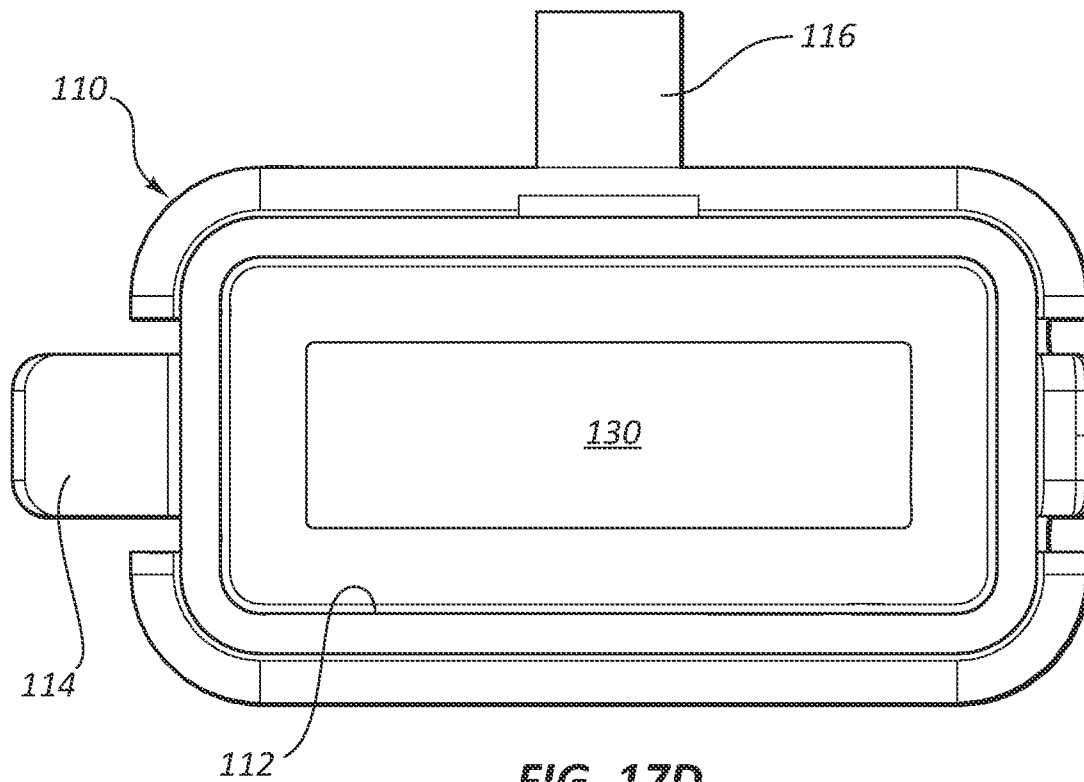


FIG. 17D

12/26

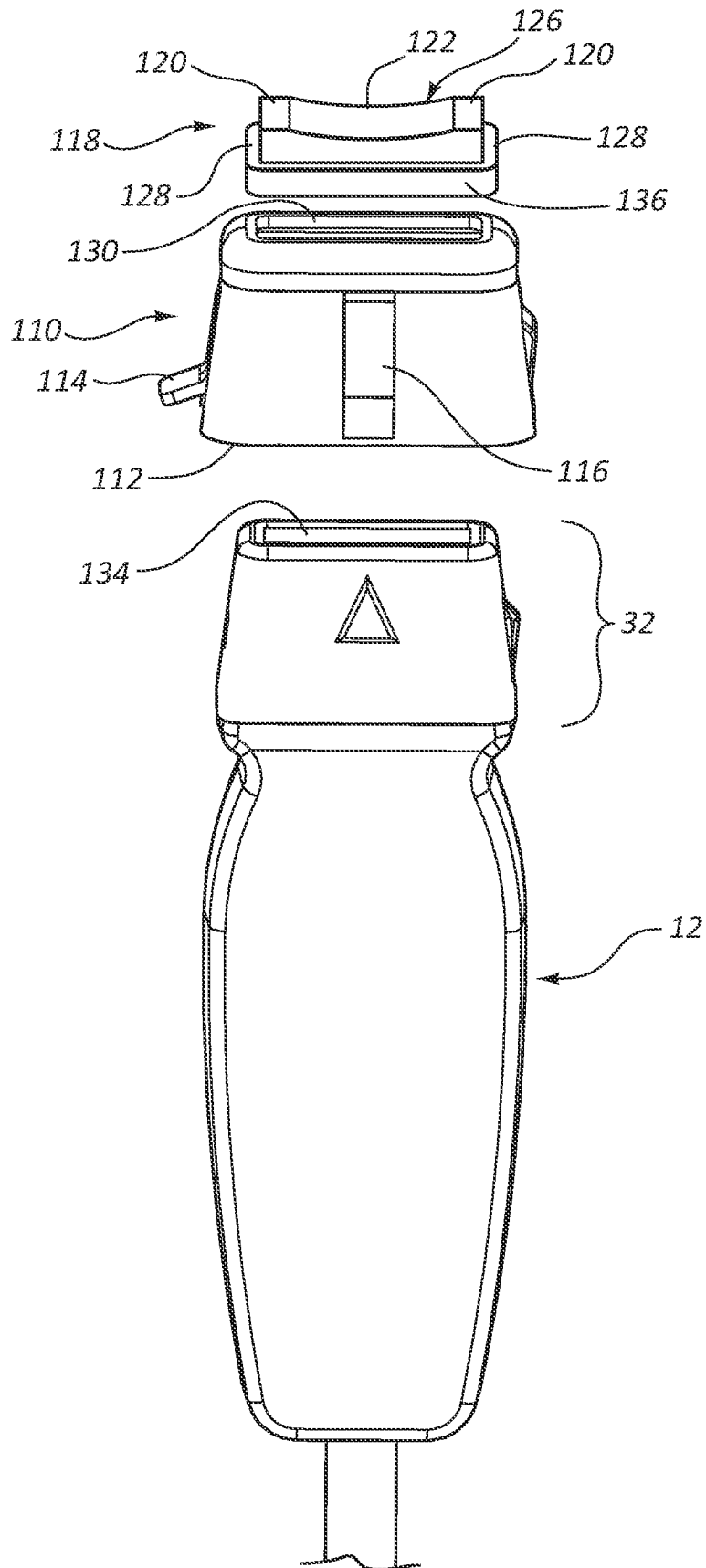
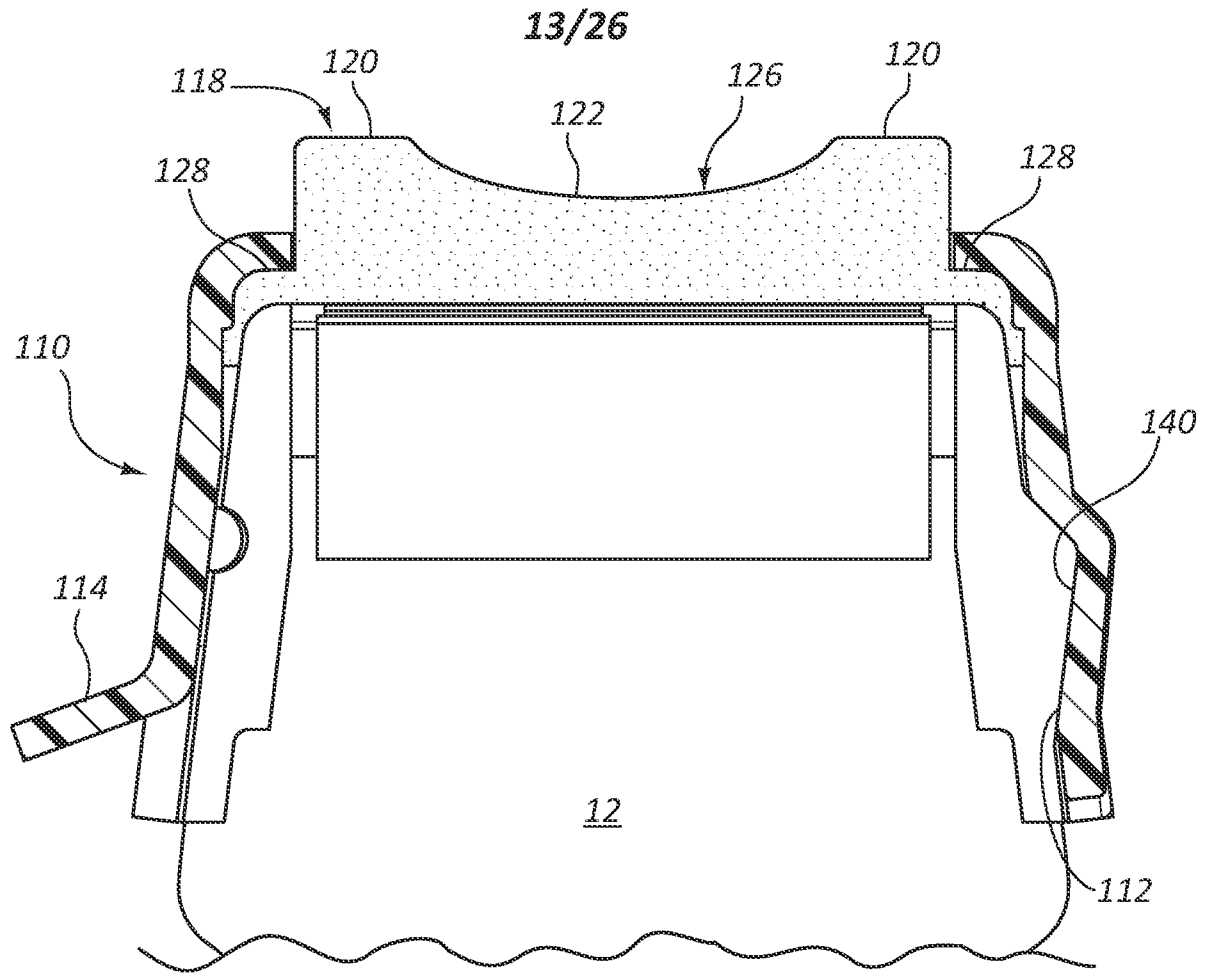
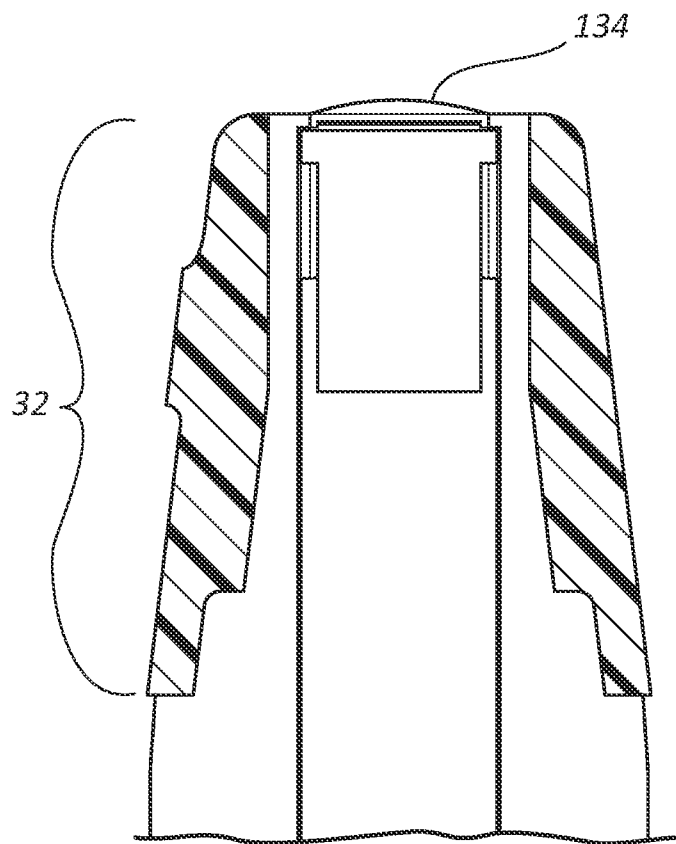


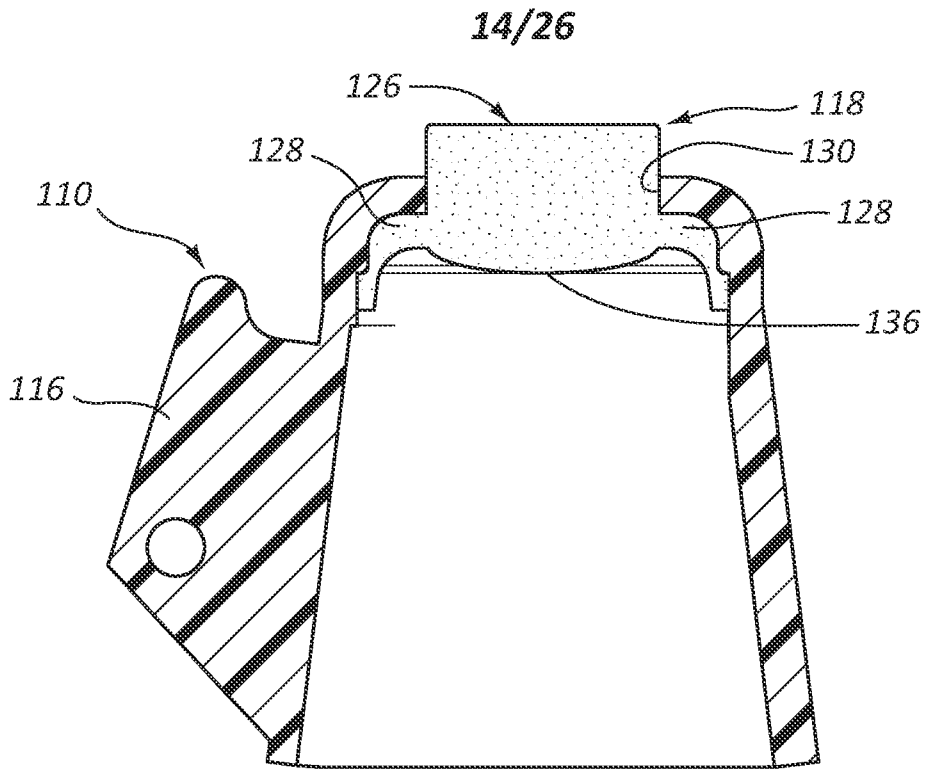
FIG. 18A



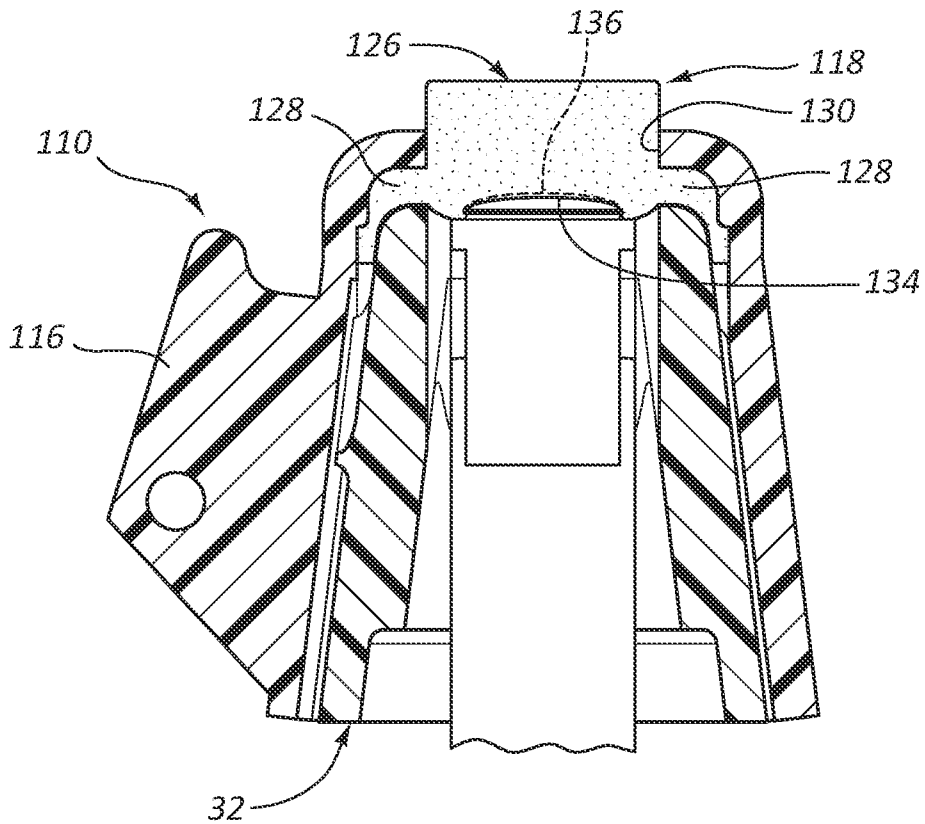
**FIG. 18B**



**FIG. 19**



**FIG. 20**



**FIG. 21**

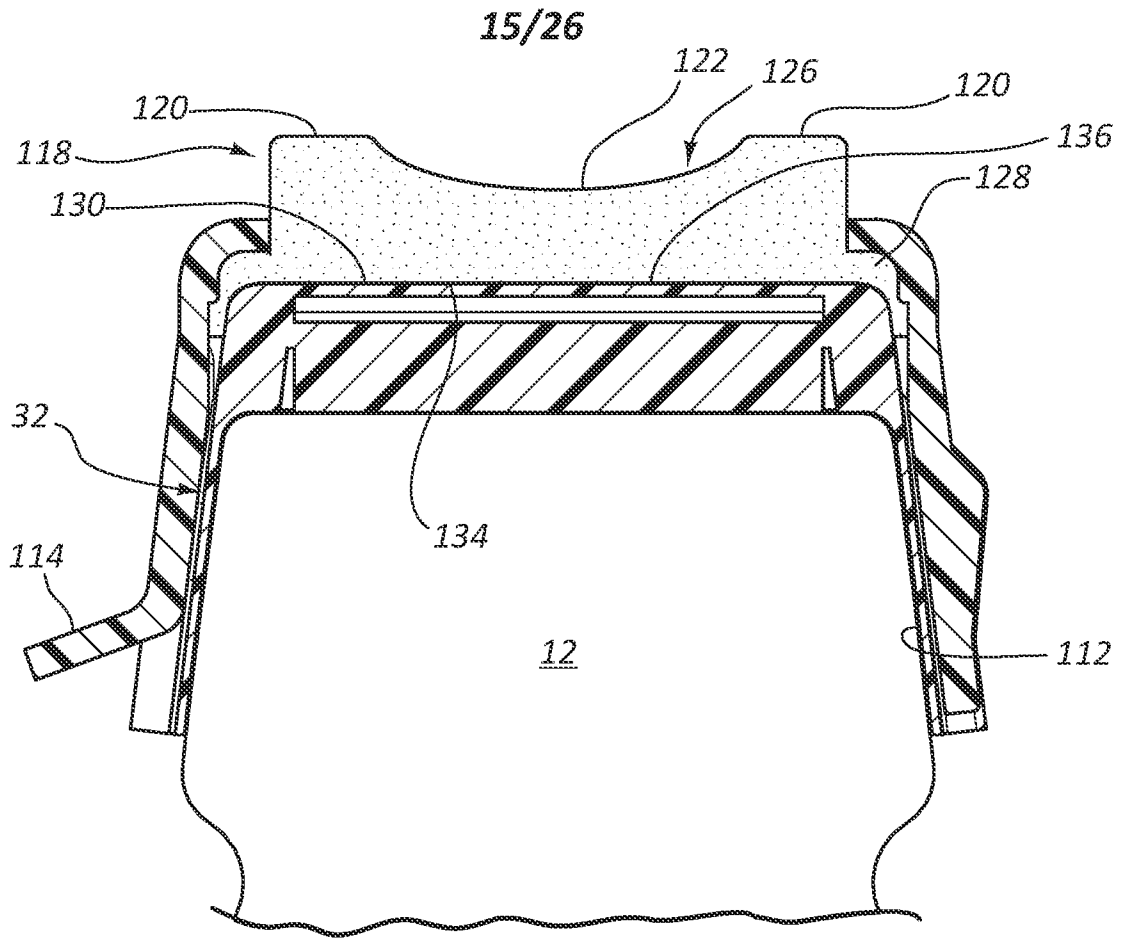


FIG. 22

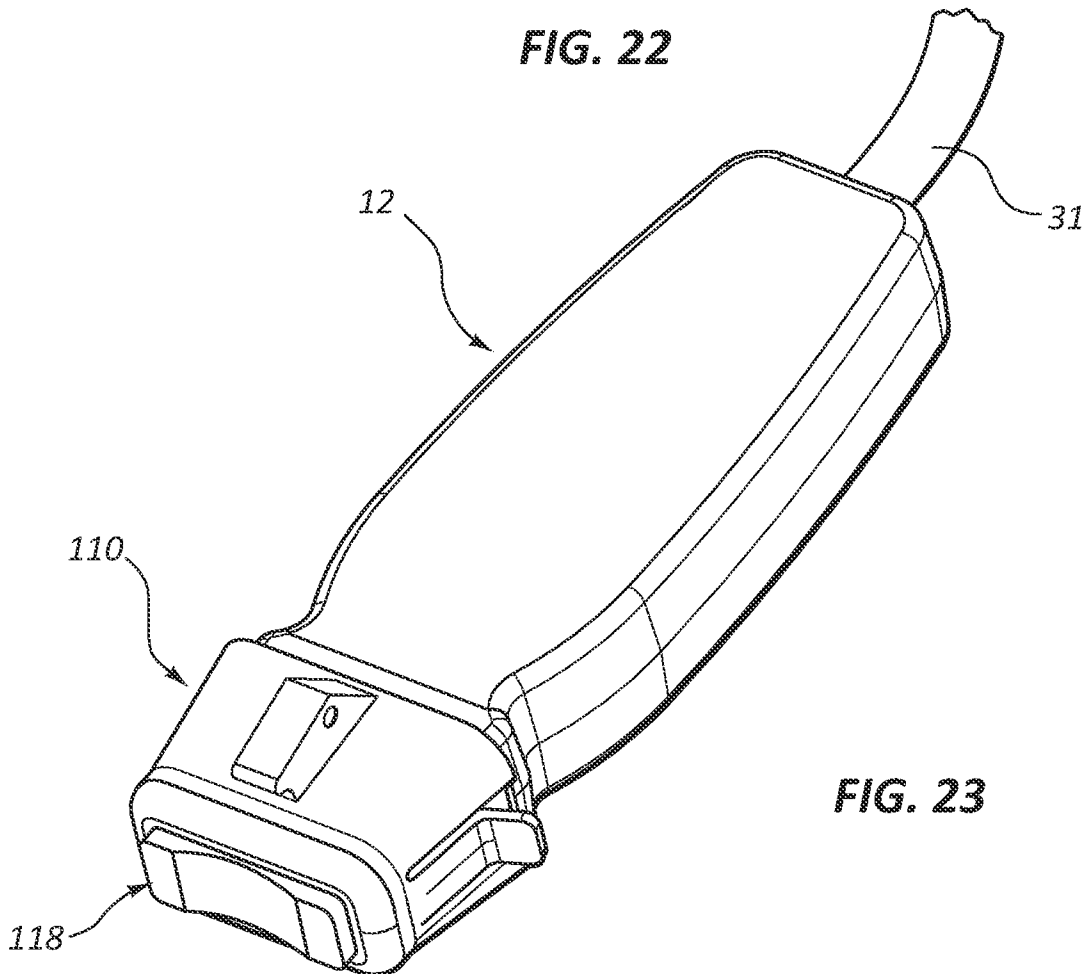


FIG. 23

16/26

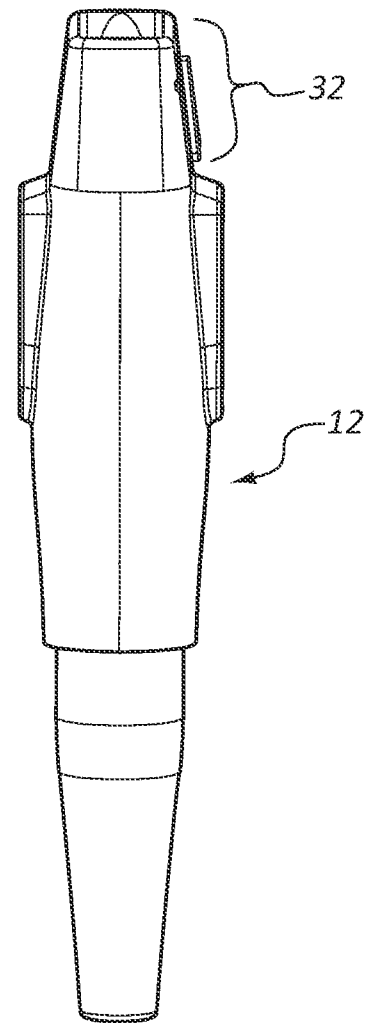
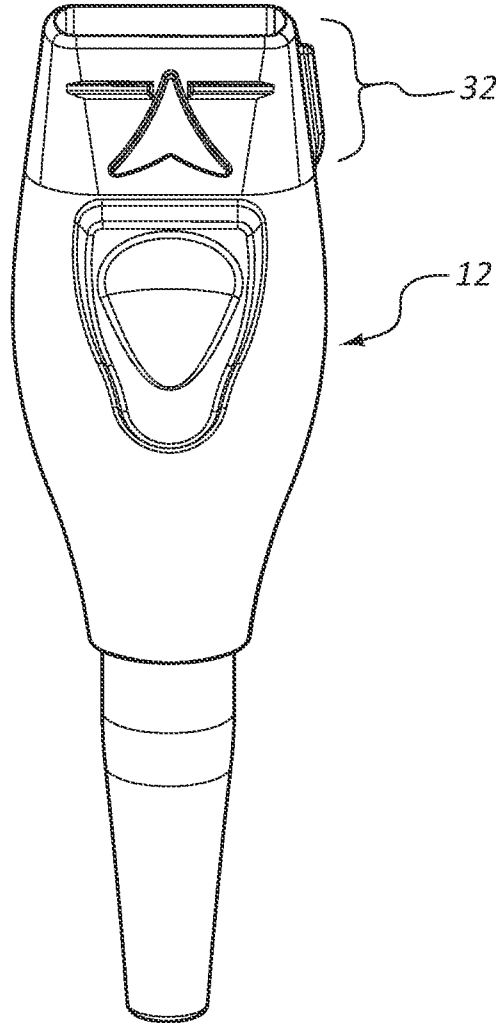
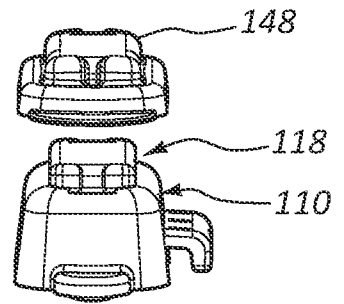
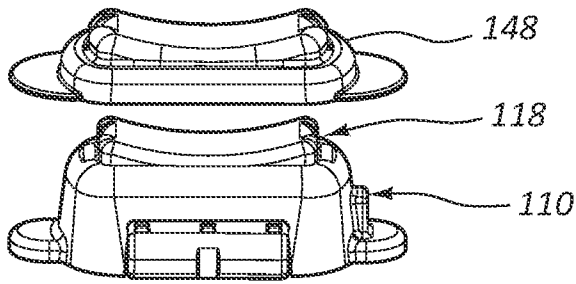


FIG. 24A

FIG. 24B

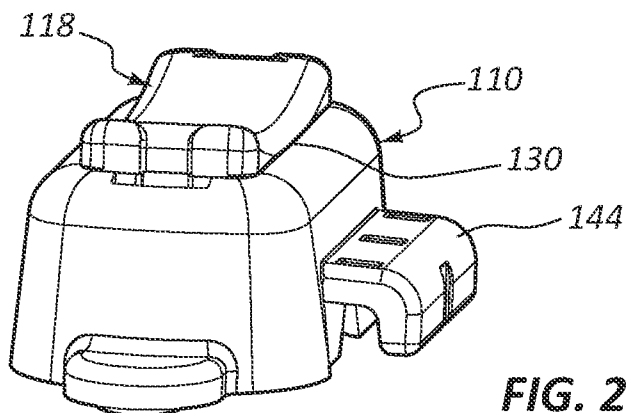


FIG. 24C

17/26

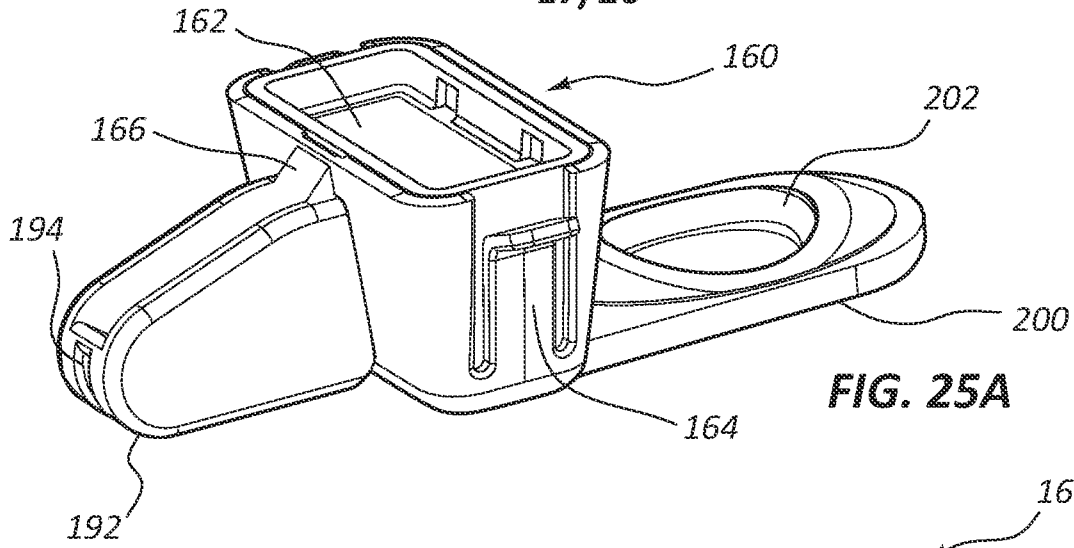


FIG. 25A

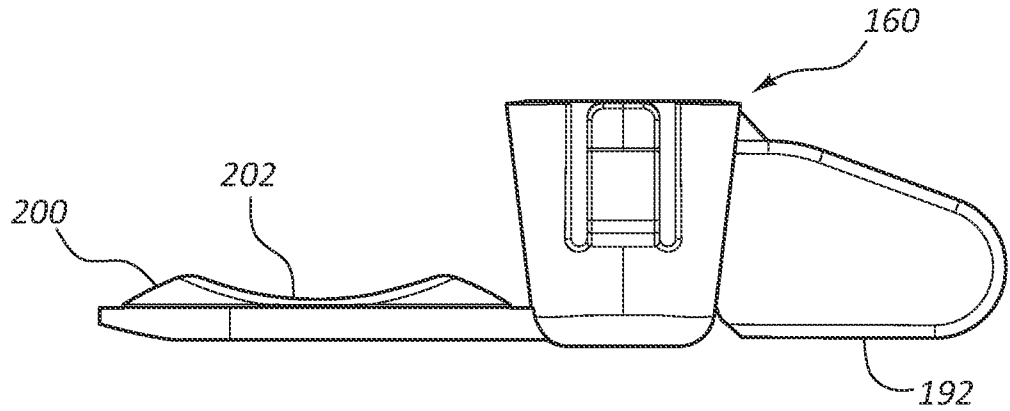


FIG. 25B

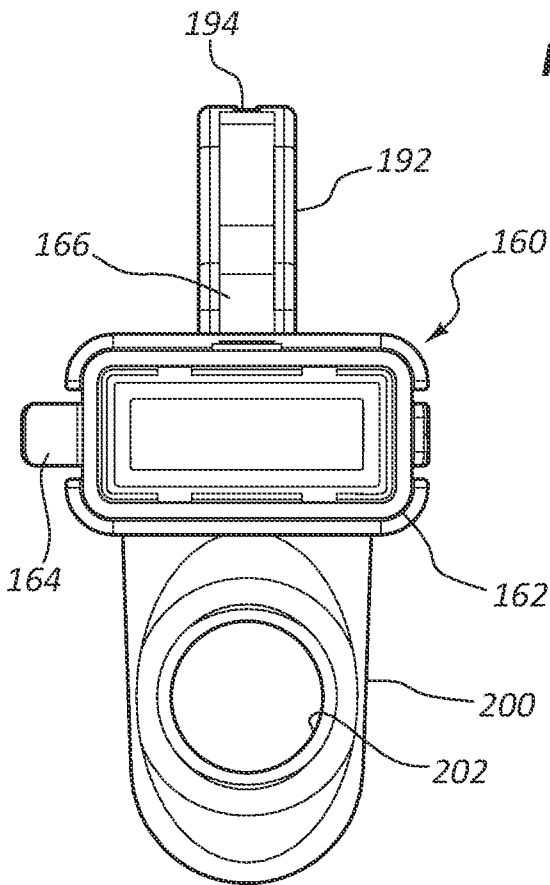


FIG. 25C

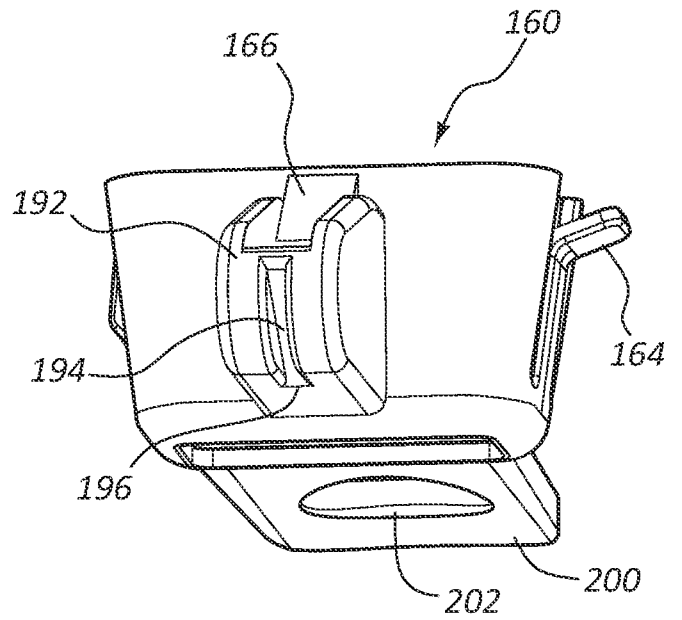


FIG. 25D

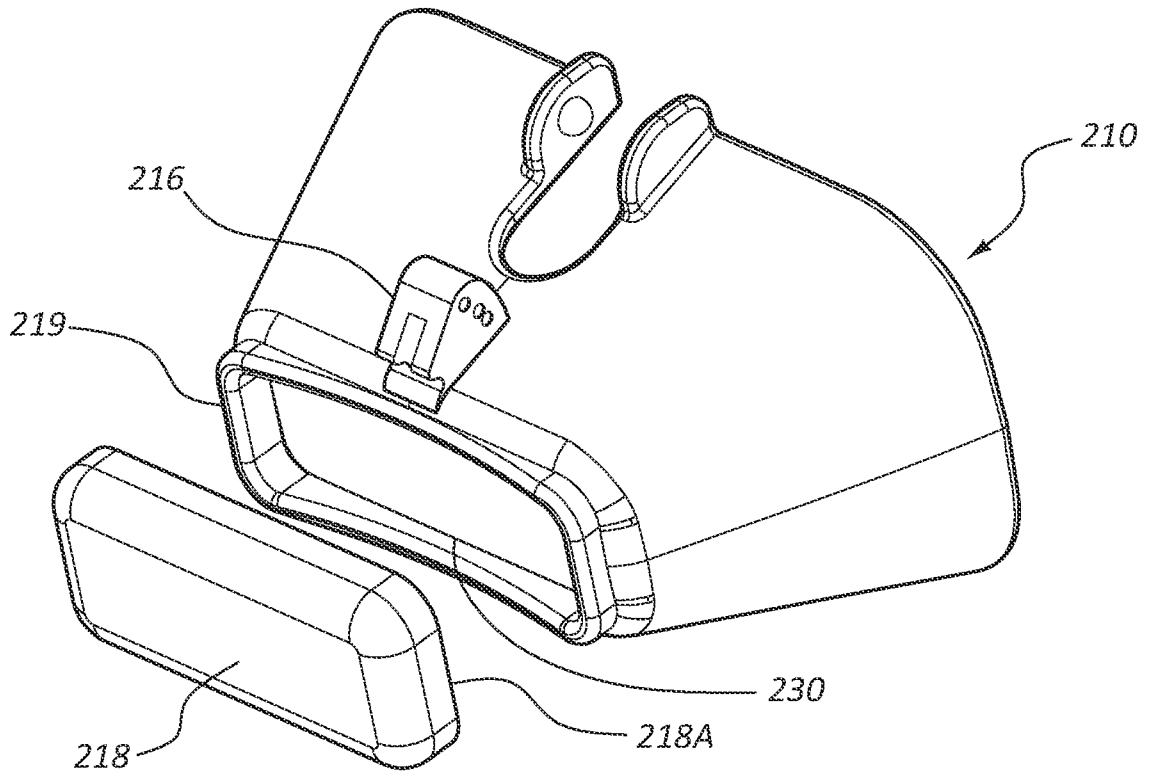


FIG. 26A

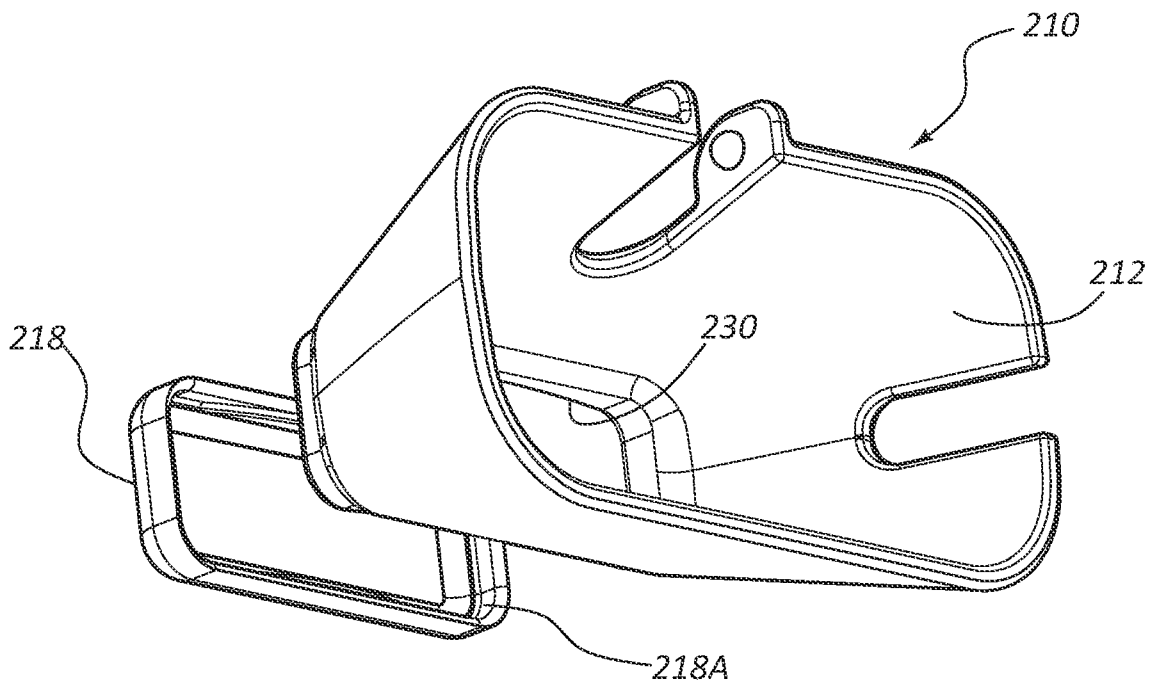


FIG. 26B

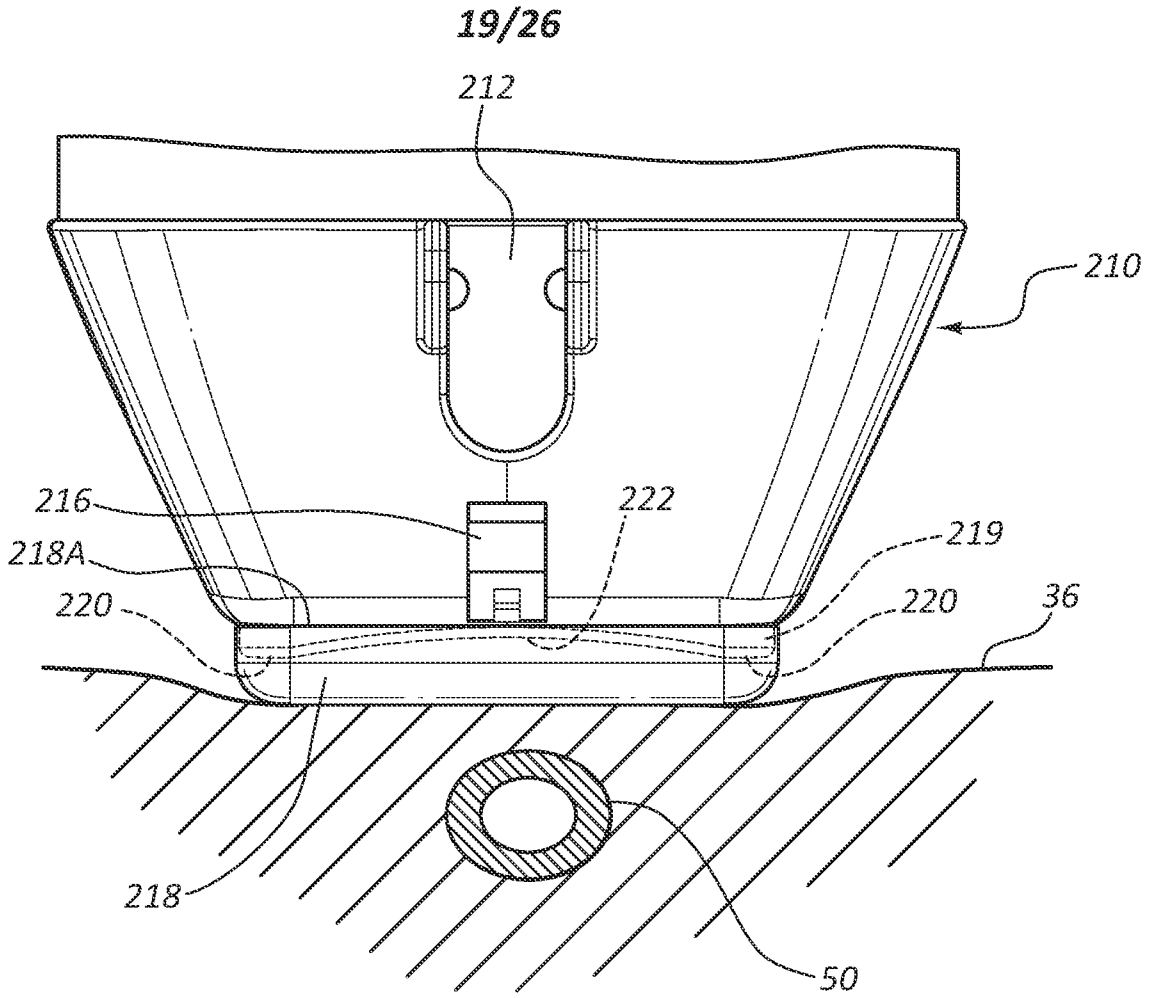


FIG. 27

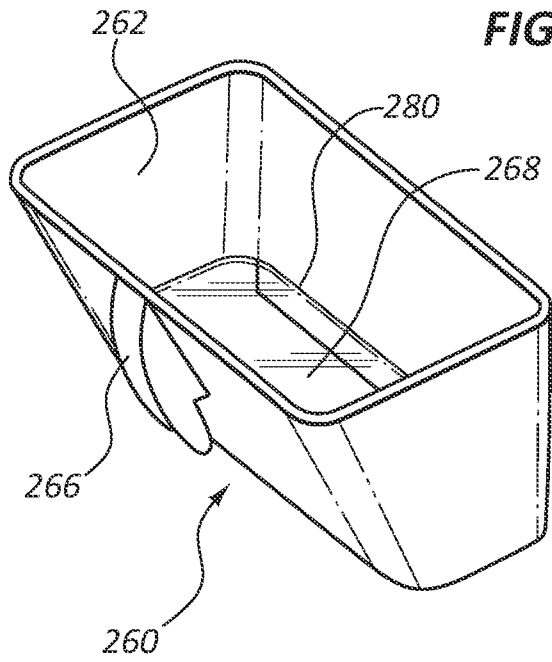


FIG. 28A

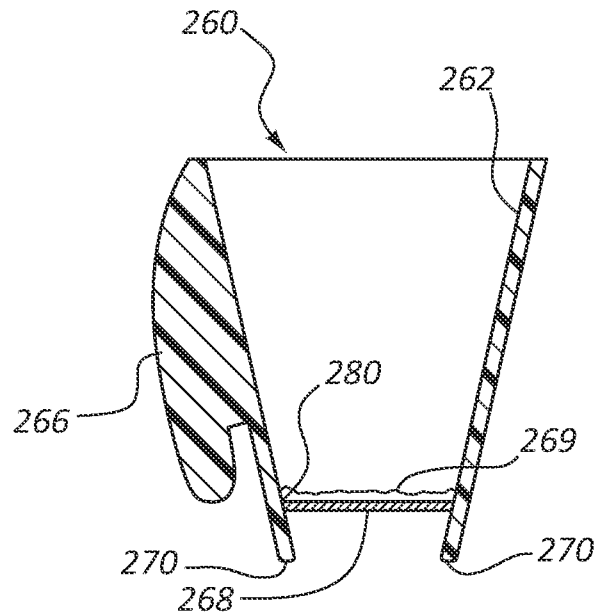


FIG. 28B

20/26

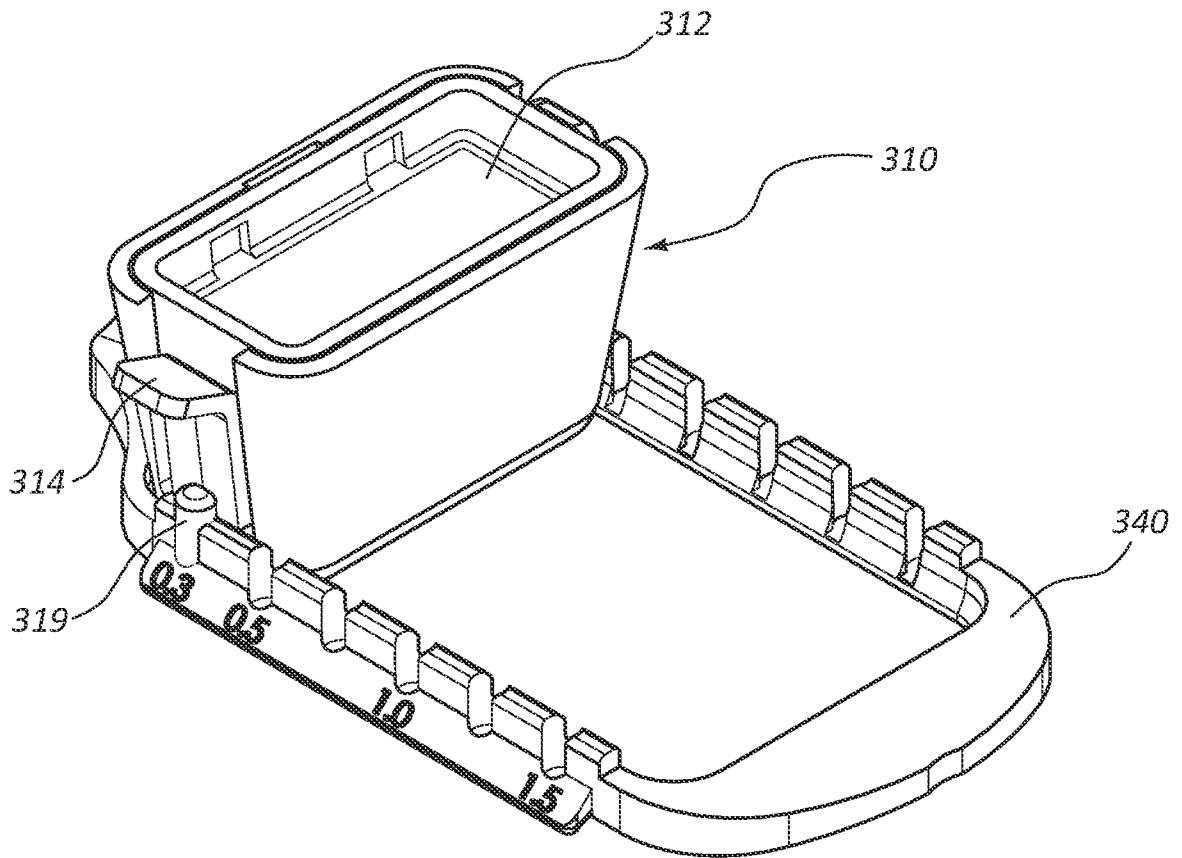


FIG. 29A

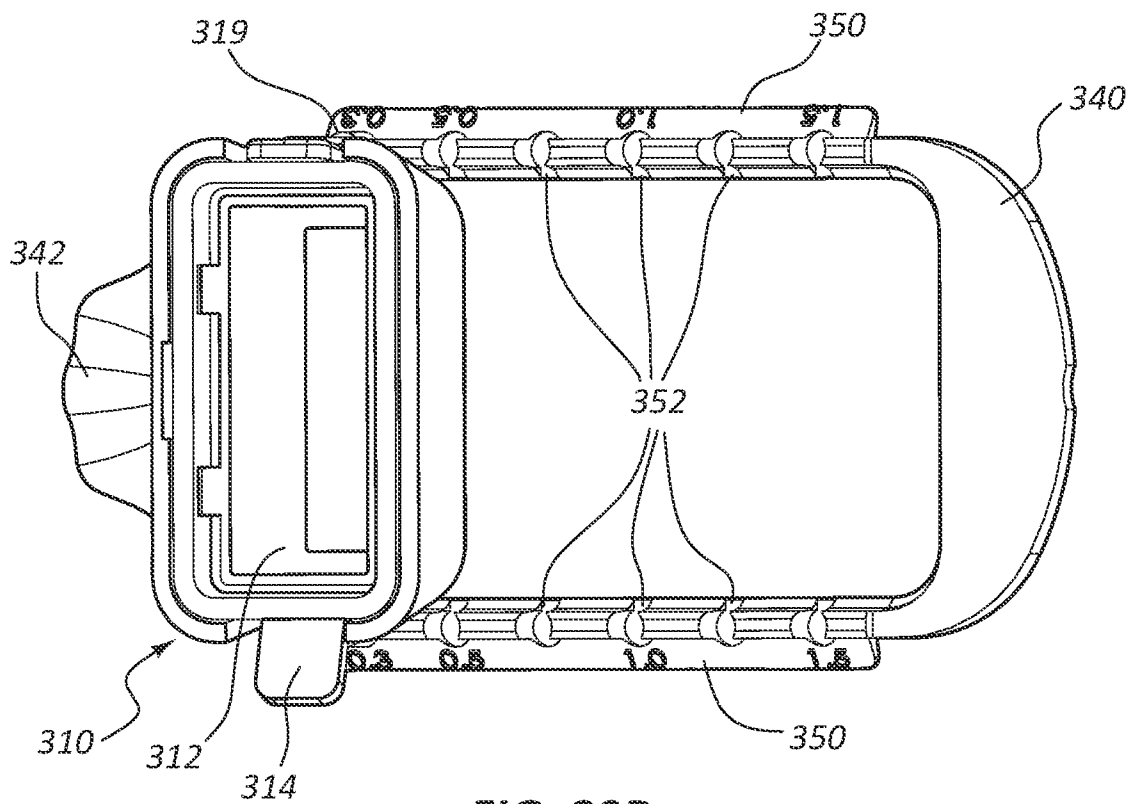


FIG. 29B

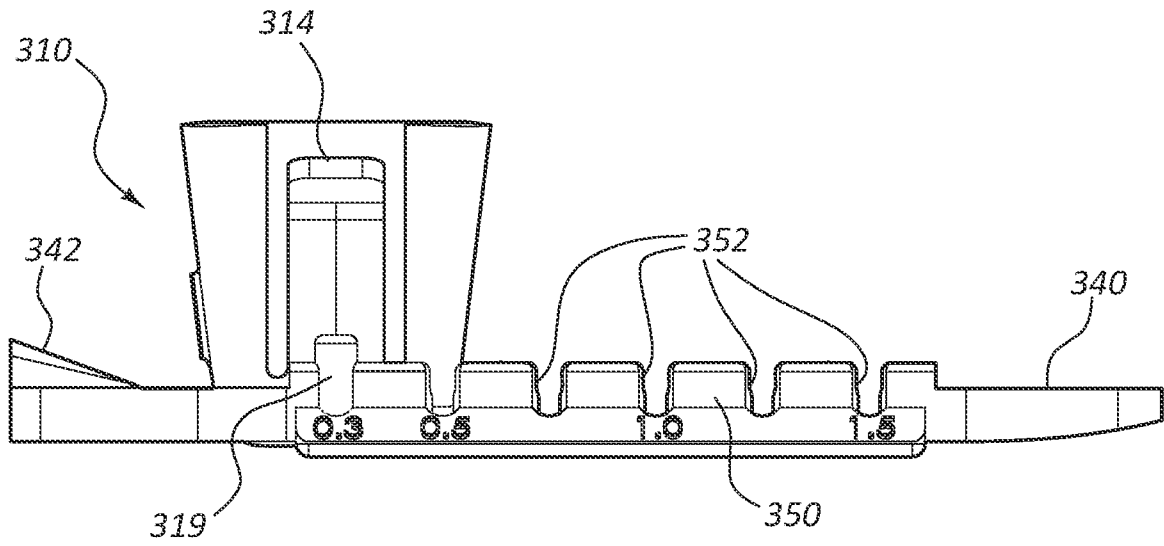


FIG. 29C

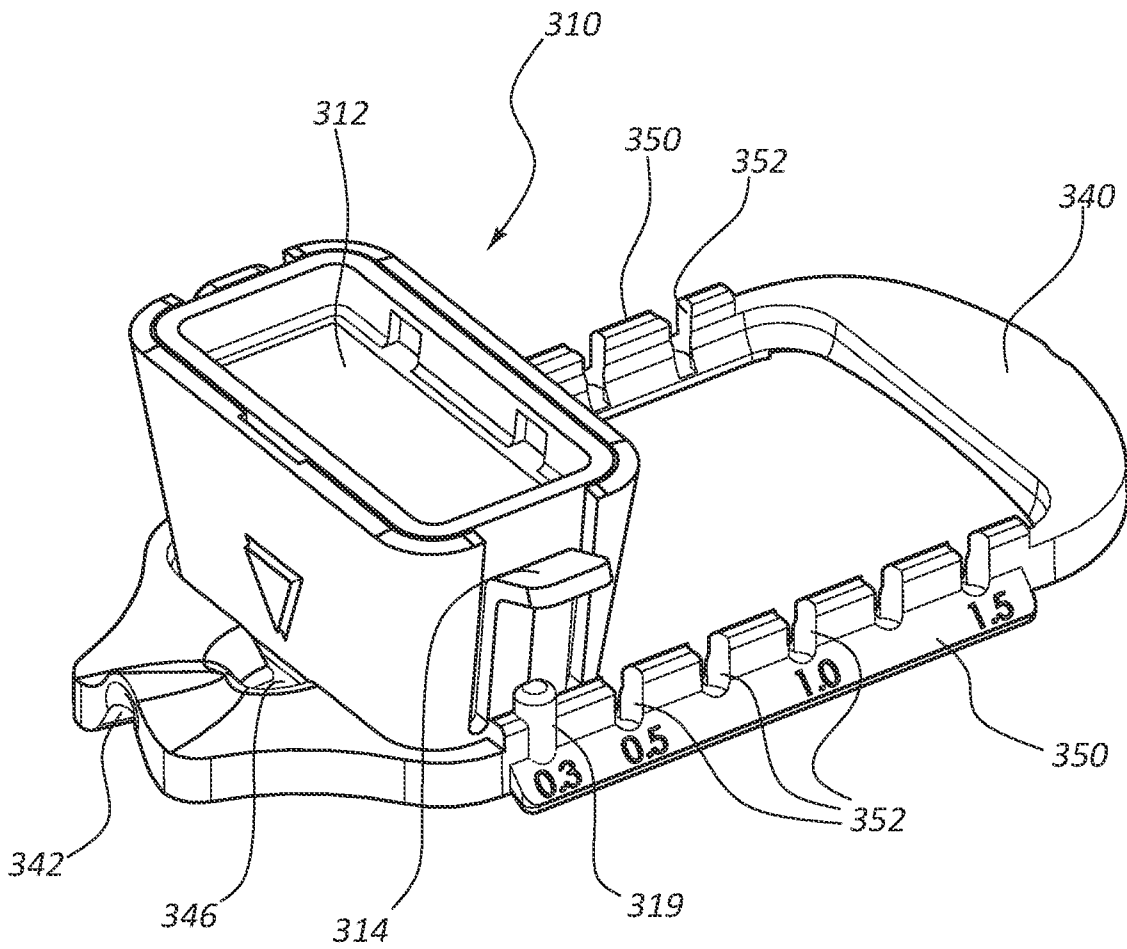
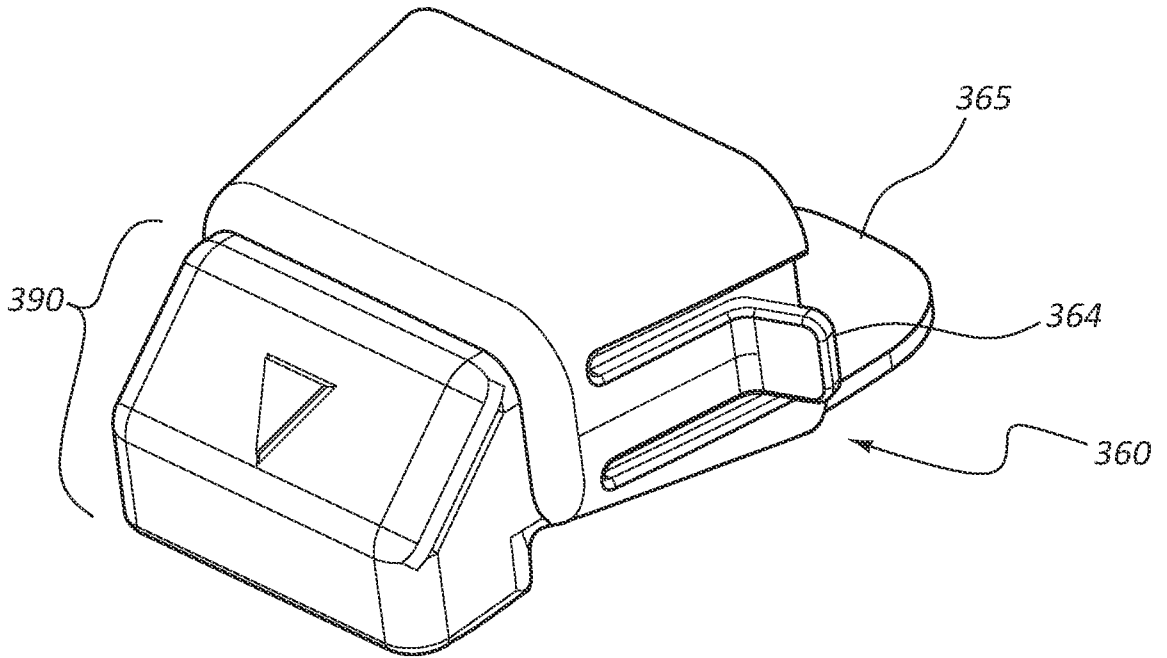
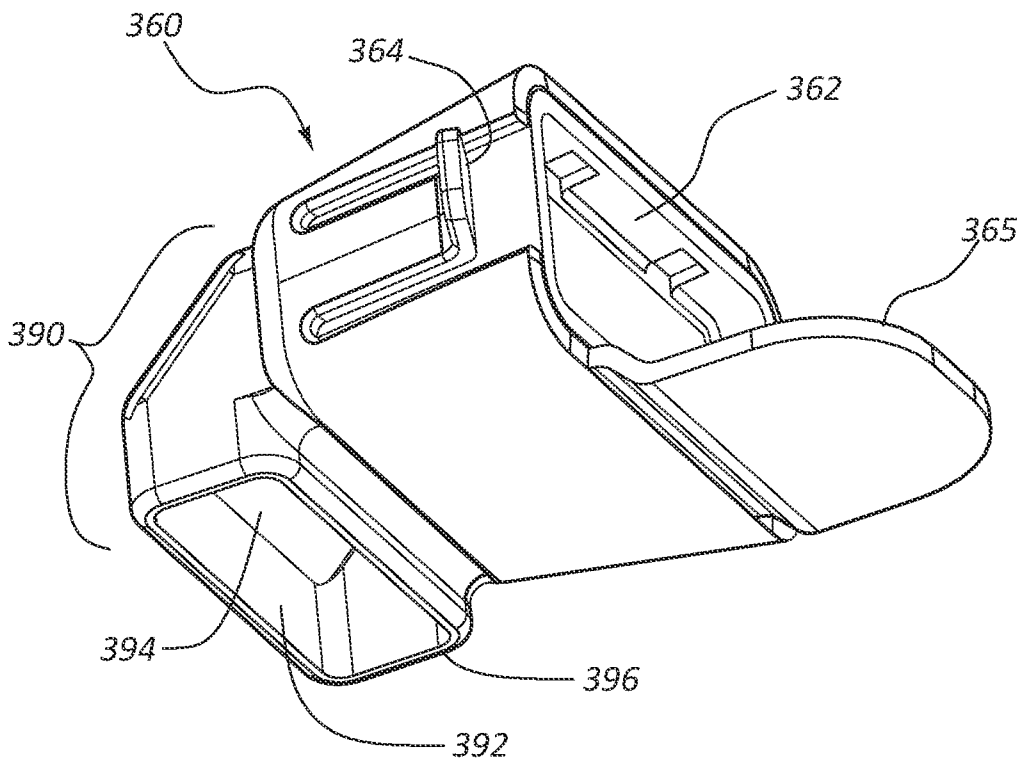


FIG. 29D



**FIG. 30A**



**FIG. 30B**

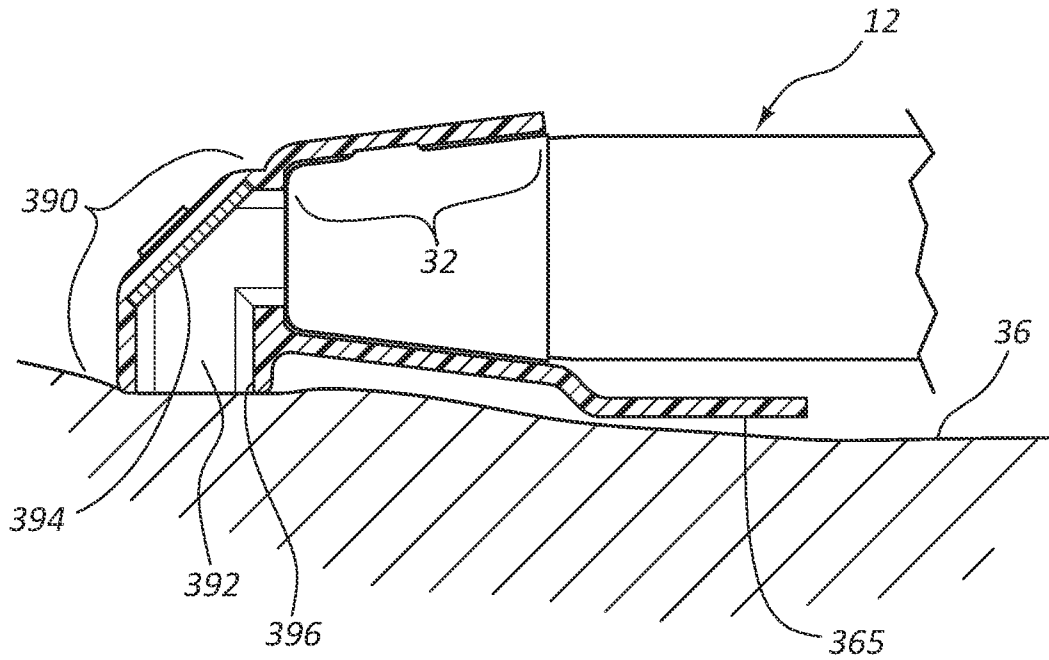


FIG. 31

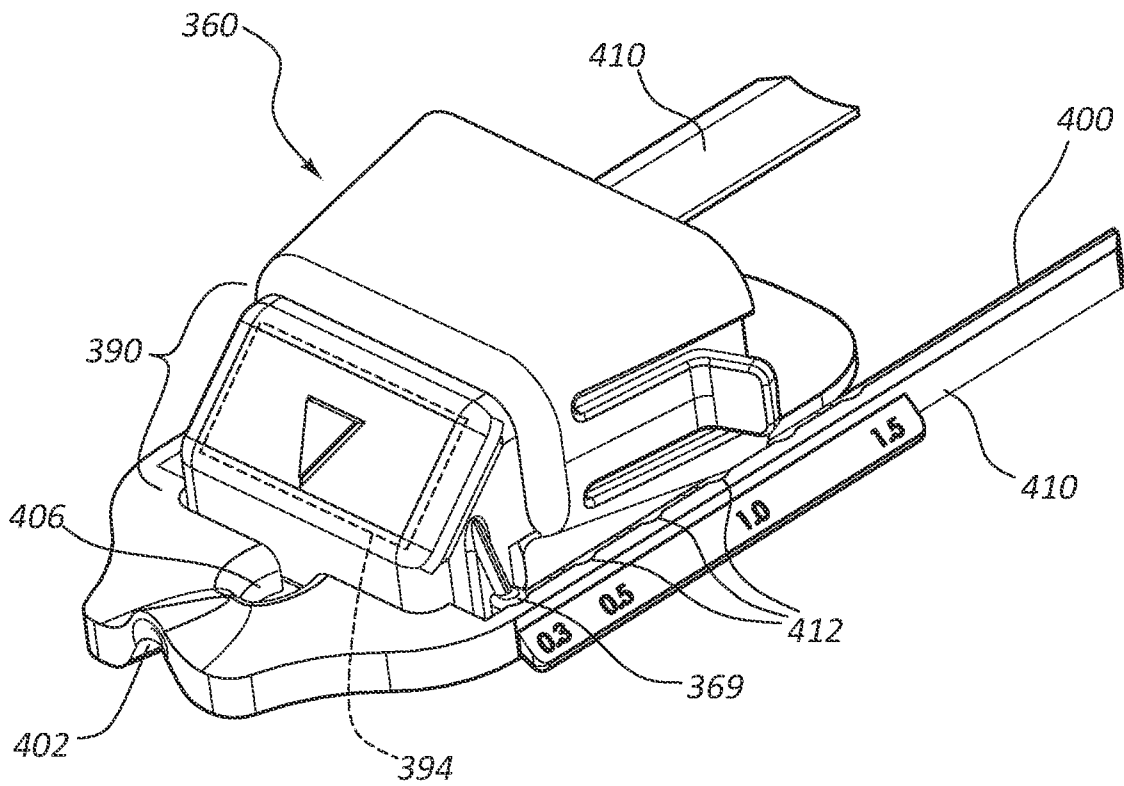


FIG. 32

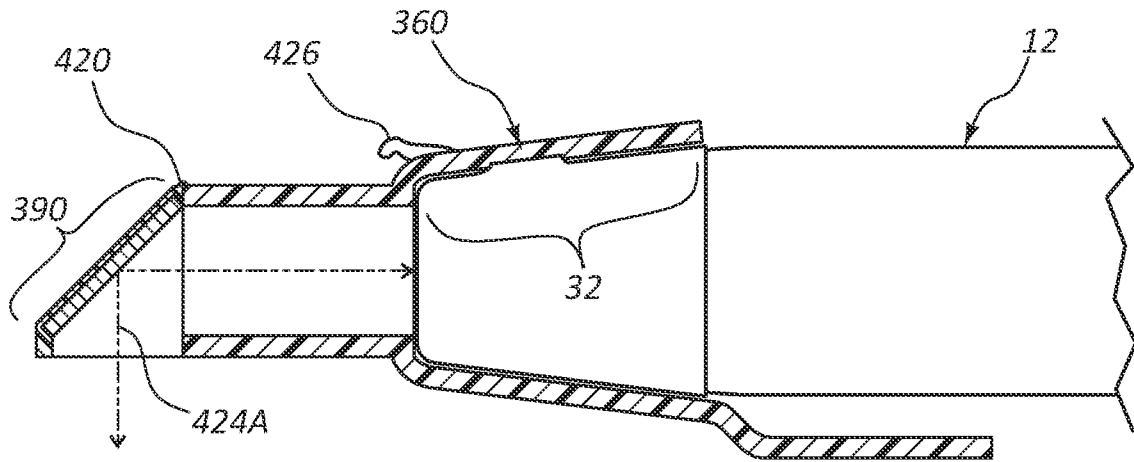


FIG. 33A

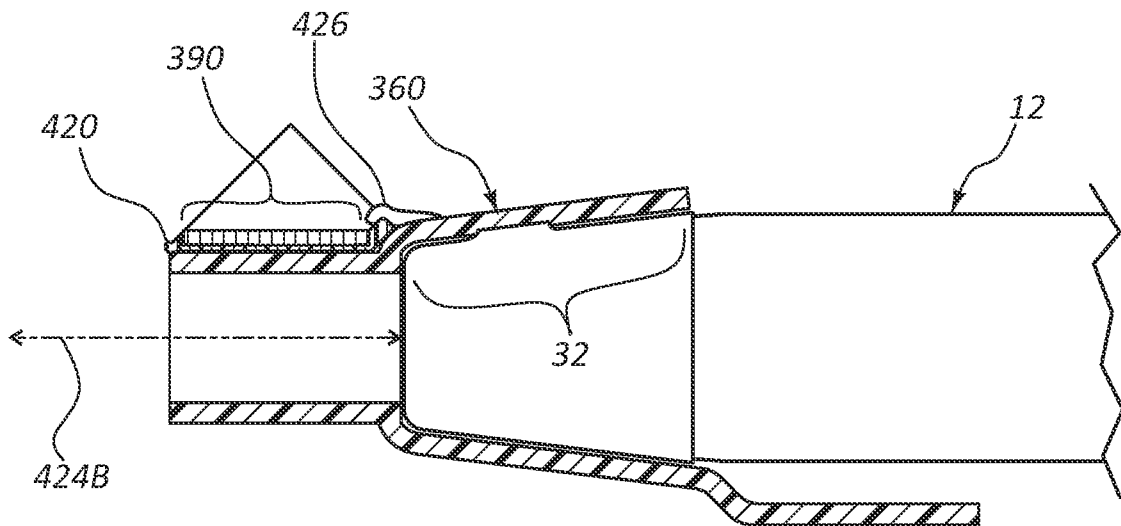
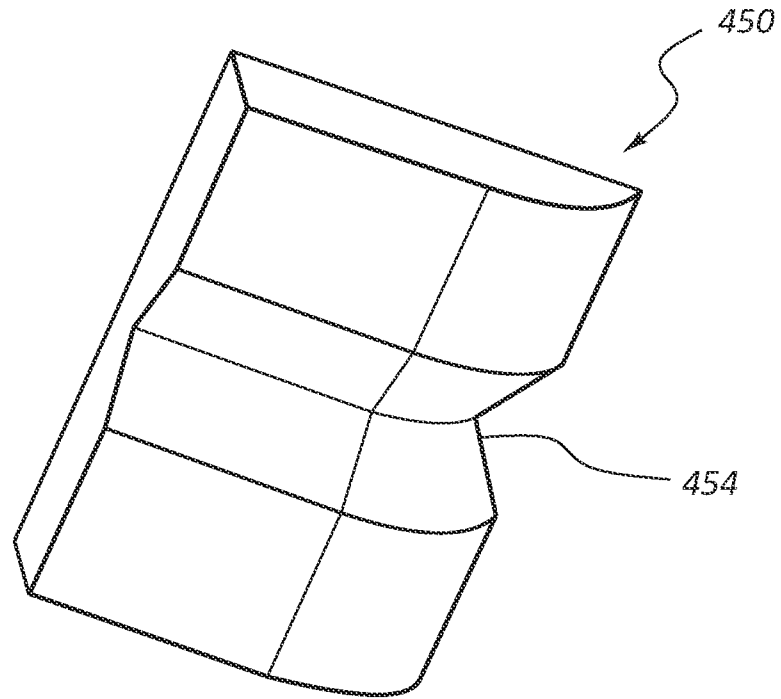


FIG. 33B



**FIG. 34**

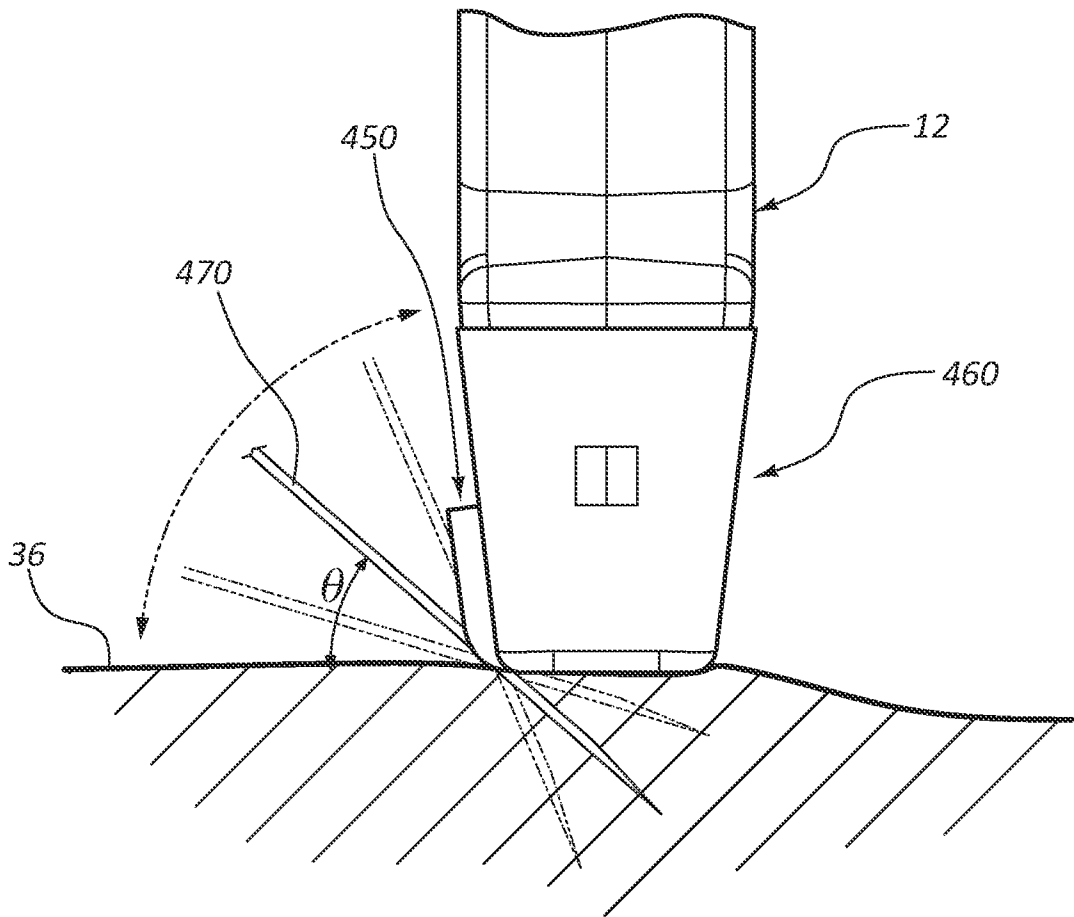


FIG. 35A

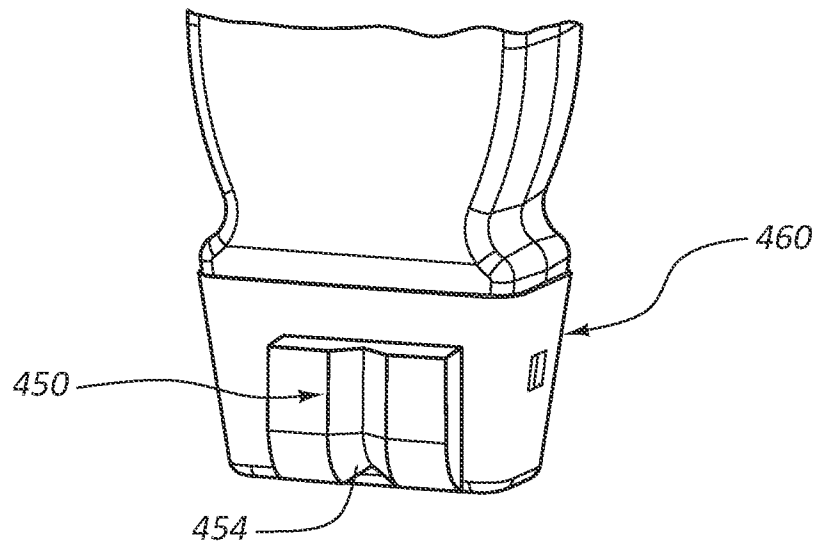


FIG. 35B