

(19)



(11)

EP 3 753 541 B1

(12)

EUROPEAN PATENT SPECIFICATION

(45) Date of publication and mention of the grant of the patent:
25.10.2023 Bulletin 2023/43

(51) International Patent Classification (IPC):
A61G 7/057 (2006.01) A61G 7/05 (2006.01)

(21) Application number: **19181680.0**

(52) Cooperative Patent Classification (CPC):
A61G 7/05776; A61G 7/0527

(22) Date of filing: **21.06.2019**

(54) ANTI-DECUBITUS METHOD AND DEVICE

ANTIDEKUBITUSVERFAHREN UND -VORRICHTUNG

PROCÉDÉ ET DISPOSITIF ANTI-DÉCUBITUS

(84) Designated Contracting States:
AL AT BE BG CH CY CZ DE DK EE ES FI FR GB GR HR HU IE IS IT LI LT LU LV MC MK MT NL NO PL PT RO RS SE SI SK SM TR

(72) Inventor: **PRETTO, Luca**
36043 Camisano Vicentino (IT)

(43) Date of publication of application:
23.12.2020 Bulletin 2020/52

(74) Representative: **Kraus & Weisert**
Patentanwälte PartGmbB
Thomas-Wimmer-Ring 15
80539 München (DE)

(73) Proprietor: **Evohealth Srl**
35036 Borgo Veneto (PD) (IT)

(56) References cited:
WO-A1-2015/132560 US-A- 6 014 784
US-A1- 2005 091 752

EP 3 753 541 B1

Note: Within nine months of the publication of the mention of the grant of the European patent in the European Patent Bulletin, any person may give notice to the European Patent Office of opposition to that patent, in accordance with the Implementing Regulations. Notice of opposition shall not be deemed to have been filed until the opposition fee has been paid. (Art. 99(1) European Patent Convention).

Description

[0001] The present invention relates to a method for calibrating an anti-decubitus mattress and to a device capable of performing such method.

Prior art

[0002] Anti-decubitus mattresses are known in the art for preventing ulcers, bedsores and the likes in bedridden people. The general approach of known anti-decubitus mattresses is to provide a plurality of cells connected to each to form a mattress and to inflate/deflate the cells in an interleaved manner, so as to improve blood circulation and in order to avoid a prolonged contact of the same body parts with the mattress.

[0003] Figure 1A schematically illustrates a side view of an anti-decubitus mattress known from the prior art, figure 1B schematically illustrates a top view of the same anti-decubitus mattress. The anti-decubitus mattress 1000 has a plurality of cells 1100, 1200, connected in an interleaved manner. By alternatively inflating/deflating cells 1100, 1200, an anti-decubitus operation can be obtained. For example, after all cells 1100, 1200 have been inflated, cells 1100 can be partially deflated while cells 1200 are kept inflated. Subsequently, cells 1200 can be inflated again while cells 1100 are partially deflated, and so on. The alternance of the body support by means of cells 1100, 1200 provides the anti-decubitus functionality.

[0004] It will be clear that the placement of the cells 1100, 1200 of anti-decubitus mattress 1000 can be changed, as long as an interleaved operation of the cells achieves movement of the body. An alternative example of a possible arrangement of the cells is illustrated in the anti-decubitus mattress 2000 of figure 2. The operation of anti-decubitus mattress 2000 is similar to that of anti-decubitus mattress 1000.

[0005] It will also be clear that the air connections to the various cells 1100, 1200 can be implemented in various manners, not illustrated for clarity of illustrations.

[0006] As described above, the cells of anti-decubitus mattress 1000 are alternatively inflated/deflated over time. This allows the user of the anti-decubitus mattress 1000 the possibility to choose the pressure values of the cells 1100, 1200. In particular, it is advantageous to adapt the inflating pressures to the user of the anti-decubitus mattress 1000. Generally speaking, lower pressure values are generally preferred for lighter users while higher pressure values are generally preferred for heavier users.

[0007] This poses the user, or the operator, of the anti-decubitus mattress 1000 with the need to select appropriate pressure values. The selection can be done by trial and error, though this is not ideal as the error can result in significant medical issues. It is thus preferable to provide an automatic approach for automatically selecting the most appropriate pressure for each user.

[0008] Various solutions have been suggested in the art, all of which, however, present various drawbacks.

[0009] One approach consists in placing a sensing mat under the anti-decubitus mattress. The sensing mat is provided with a deformable rubber pipe having its input connect to the none connecting the input of the anti-decubitus mattress and the output of an air compressor inflating the anti-decubitus mattress. The output of the rubber pipe is free. Thanks to this construction, the maximum pressure which can be used to inflate the anti-decubitus mattress is the pressure at which the deformable rubber pipe opens, thus leading the air outside. In this manner, a heavier user placed on the anti-decubitus mattress will exert more pressure on the anti-decubitus mattress and, in turn, on the deformable rubber pipe of the sensing mat, thus closing it, until a pressure high enough to open it again is achieved. This results in an increased pressure in the air inside the rubber pipe, which automatically forces a higher pressure for inflating the anti-decubitus mattress. Conversely, a lighter user will require less pressure to open the rubber pipe, which automatically results in a lower pressure being used to inflate the anti-decubitus mattress.

[0010] This system has a number of disadvantages.

[0011] One important disadvantage is that, for the system to operate correctly, the compressor has to run constantly. Since the system relies on an open deformable rubber pipe, air will keep getting out of the anti-decubitus mattress, due to leaks and/or the movements of the anti-decubitus mattress and/or of the user. The constant running of the compressor results in an increased noise, energy consumption, and to a generally reduced operating life of the compressor. In some implementations, this problem is partially solved by providing a first compressor for inflating the anti-decubitus mattress and a second, separate, compressor for the sensing mat. This solution however still requires the compressor for the sensing mat to operate constantly, thus only partially shifting the problem.

[0012] Moreover, if the anti-decubitus mattress is bent, for instance when lifting part of the body of the user. the deformable rubber pipe risks remaining blocked due to the bent in the sensing mat, thus unnecessarily increasing the inflating pressure of the anti-decubitus mattress.

[0013] A similar occlusion may also happen when the bed doesn't have a flat surface, as any raised surface poses the risk of occluding a portion of the deformable rubber pipe. As it is impossible for the manufacturer to know the design of every bed on which the -decubitus mattress will be placed, this effectively requires the use of a semi-rigid layer under

the sensing mat.

[0014] An alternative known approach consists in inflating all cells 1100, 1200, to a predetermined pressure and then opening, for a predetermined time, an output valve of the anti-decubitus mattress. Once the output valve is closed, the pressure in the anti-decubitus mattress is measured. The pressure difference resulting from the air flowing out of the output valve is a function of the weight that was placed on the anti-decubitus mattress. Thus, by measuring the pressure difference, the weight of the user can be computed and the pressure of the anti-decubitus mattress can be set accordingly.

[0015] This approach reduced the use of the compressor, since air is left out of the compressed system only once, for the measuring described above. Nevertheless, this approach still presents a number of disadvantages.

[0016] One important disadvantage is the need for a precision outflow of air. The time of the outflow is easily controllable, however the output valve characteristics are more complex to maintain stable. Firstly, the output valve needs to be precisely manufactured so as to ensure that each output valve has the same outflow characteristics. Moreover, even if precisely manufactured, the output valve may become partially obstructed during time, for instance by external objects such as bed linens, or by dirt in the compressed air. Even a partial obstruction has the result that the outflow characteristics of the output valve change, thus invalidating the computational assumptions which are used to derive the weight of the user from the measured pressure difference.

[0017] Moreover, the pressure variation, that is the difference between initial pressure and pressure after the outflow, is not only a function of the weight placed on the anti-decubitus mattress but also on the initial pressure. This requires the system to be capable of setting a known and stable value of the initial pressure, which increases the complexity of the system.

[0018] Another alternative approach, for instance known from patent application ITVR20120226, applies a similar concept except that, instead of measuring the pressure at the end of a predetermined time, the outflow of air is started and interrupted at a predetermined initial and final pressure, and the time for the anti-decubitus mattress to deflate from the initial to the final pressure is measured instead.

[0019] This approach does not solve the issues related to the required precision of the outflow valve, and the stability of its outflow characteristics during time.

[0020] Yet a further approach is known, in which the cells 1100, 1200 are all inflated at the same pressure and then only one set of cells, for instance cells 1100, are deflated. By doing so, the weight will be supported by the remaining cells, namely cells 1200, resulting in a pressure increase. By measuring the pressure increase in the cells 1200, the weight of the user can be computed.

[0021] This approach also presents several drawbacks.

[0022] It is necessary to precisely measure the pressure in the cells, which requires precise pressure sensors. Such pressure sensors are needed in the cells which remain inflated, for instance cells 1200, but also in the cells which are deflated, namely cells 1100, to be able to detect the correct deflation.

[0023] This latter point introduces an additional drawback, in that the placement of the pressure sensor in the deflated cells is quite critical, as the pressure in the deflating cells will have a gradient and thus it is not simple to obtain a measurement correctly indicating when the deflating cells are actually deflated with a single pressure sensor.

[0024] Moreover, the deflation of cells 1100 also implies that the user has to lie only on cells 1200 for some time, which may be uncomfortable or painful. In some cases, the lack of support from deflated cells 1100 may thus not be acceptable.

[0025] Additionally, the body parts which are placed over deflated cells 1100 may get in contact with the bed's surface. This reduced the weight which is supported by the inflated cells 1200 and thus results in an incorrect computation of the user's weight.

[0026] As it can be seen, the current systems are affected by a number of drawbacks. Anti-decubitus mattresses according to the prior art are known, for instance, from documents WO 2015/132560 A1 and US 2005/0091752 A1.

[0027] It is thus an object of the invention to overcome one or more of the drawbacks described above. More generally, it is an object of the invention to provide a method and a corresponding device for the operation of an anti-decubitus mattress which can increase the user's comfort with an efficient configuration.

Summary of the invention

[0028] The above object is achieved by the teaching of the invention, which is defined by the independent claims.

[0029] Pressure values will be expressed in Torrs throughout the rest of the description, wherein 1 Torr corresponds to 133.3224 Pa.

[0030] The invention is based on the general concept that the weight of the user can be computed by a pressure measurement. In particular, the pressure measurement can be done on some of the cells of the mattress after some other cells have been inflated more, so as to support more of the body of the user.

[0031] In particular, an embodiment of the invention can relate to a method for calibrating an anti-decubitus mattress, the anti-decubitus mattress comprising a plurality of first cells and a plurality of second cells, the method comprising the

steps of: inflating the first cells at a second pressure value, measuring a third pressure value of the second cells, calibrating the anti-decubitus mattress based on the third pressure value.

[0032] Thanks to this approach it is advantageously possible to calibrate the anti-decubitus mattress without deflating some of the cells, as in the prior art systems, thus avoiding the disadvantages associated with such deflation.

[0033] In some embodiments the second pressure value can be comprised between 15 and 50 Torr, more preferably between 25 and 35 Torr.

[0034] Thanks to this approach it is advantageously possible to calibrate the anti-decubitus mattress without lifting too much of the weight on the first cells. This provides the advantage that, even during the calibration, the weight of the user is not supported entirely by only some cells, as it may happen in the prior art, but it remains distributed among the first cells and second cells, even if the former take on more weight during the calibration.

[0035] In some embodiments a difference between the second pressure value and the first pressure value can be comprised between 5 and 35 Torr, more preferably between 10 and 20 Torr.

[0036] Thanks to this approach it is advantageously possible to calibrate the anti-decubitus mattress without lifting too much of the weight on the first cells. This provides the advantage that, even during the calibration, the weight of the user is not supported entirely by only some cells, as it may happen in the prior art, but it remains distributed among the first cells and second cells, even if the former take on more weight during the calibration.

[0037] In the invention before the inflating step the first cells and the second cells are inflated at a first pressure value.

[0038] Thanks to this approach it is advantageously possible to provide an initial inflation ensuring that the user of the mattress can comfortably lie on the mattress prior to, and during, the calibration.

[0039] In the invention the calibrating step comprises computing a weight value based on the third pressure value.

[0040] Thanks to this approach it is advantageously possible to calibrate the anti-decubitus mattress based on the weight value and/or to show the weight value to an operator.

[0041] In the invention the weight value is computed based on a look-up table.

[0042] Thanks to this approach it is advantageously possible to provide a computation of the weight value based on a predetermined look-up table which can be programmed by taking into account the characteristics of the anti-decubitus mattress. Moreover, the use of a look-up table allows the computational resources needed for the computation of the weight to be reduced.

[0043] A further embodiment of the invention relates to a device for calibrating an anti-decubitus mattress, the anti-decubitus mattress comprising a plurality of first cells and a plurality of second cells, the device comprising: a first pipe for pneumatically connecting to the first cells, a second pipe for pneumatically connecting to the second cells, a first valve pneumatically connected to the first pipe, a second valve pneumatically connected to the second pipe, a compressor pneumatically connected to the first valve and to the second valve, and a controller configured to control the first valve, the second valve and the compressor.

[0044] Thanks to this approach it is advantageously possible to implement the calibration method in an efficient manner and with a cost-effective hardware.

[0045] In the invention the device can further comprise a pressure sensor connected to the second pipe, wherein the controller can further be configured to be connected to the pressure sensor.

[0046] Thanks to this approach it is advantageously possible to measure the pressure in the second pipe, thus allowing measuring the pressure in the second cells.

[0047] In the invention, the anti-decubitus mattress can further comprise a pressure sensor pneumatically connected to the second cells, wherein the controller can further be configured to be connected to the pressure sensor.

[0048] Thanks to this approach it is advantageously possible to measure the pressure in the second pipe, thus allowing measuring the pressure in the second cells.

Brief description of the figures

[0049]

Figure 1A schematically illustrates a side view of an anti-decubitus mattress 1000 known from the prior art;

Figure 1B schematically illustrates a top view of an anti-decubitus mattress 1000 known from the prior art;

Figure 2 schematically illustrates a top view of an anti-decubitus mattress 2000 known from the prior art;

Figure 3A schematically illustrates a method 3000 for calibrating an anti-decubitus mattress according to an embodiment of the invention;

Figure 3B schematically illustrates a setting step S3100 for populating a look-up table according to an embodiment

of the invention;

Figure 3C schematically illustrates an inflating pressure calibrating step S3200 according to an embodiment of the invention

Figures 4A and 4B schematically illustrate a side view of an anti-decubitus mattress 4000 during steps of the method 3000;

Figure 5 schematically illustrates a device 5000 for calibrating an anti-decubitus mattress according to an embodiment of the invention;

Figure 6 schematically illustrates a device 6000 for calibrating an anti-decubitus mattress according to an embodiment of the invention.

Detailed description of exemplary embodiments

[0050] Figure 3A schematically illustrates a method 3000 for calibrating an anti-decubitus mattress according to an embodiment of the invention.

[0051] For the purpose of explaining how the method 3000, reference will be made to the configuration of the anti-decubitus mattress 1000 to which pipes 4110 and 4210 are added, as visible in figures 4A and 4B. The purpose of pipe 4110 is to provide a connection to and between first cells 1100. Similarly, the purpose of second 4210 is to provide a connection to and between second cells 1200. The pipes 4110 and 4210 are only schematically represented in figures 4A and 4B for ease of understanding. It will be clear that a similar arrangement can be obtained with anti-decubitus mattress 2000 as well as any anti-decubitus mattress which comprises at least two set of cells which can be inflated at different pressure values.

[0052] In some embodiment, the method 3000 comprises an inflating step S3300, in which the first cells 1100 and the second cells 1200 are inflated at a first pressure value P1. This situation is schematically illustrated in figure 4A, in which the first pressure value P1 is indicated next to the pipes 4110 and 4210.

[0053] It will be clear that an embodiment, not part of the invention, can also be implemented without this first step, for instance because the anti-decubitus mattress is already inflated when starting the calibrating method. Alternatively, or in addition, because the first cells 1100 and the second cells 1200 are not inflated at the same pressure.

[0054] The method 3000 comprises an inflating step S3400, in which the first cells 1100 are inflated at a second pressure value P2. The second pressure value is preferably higher than the first pressure value P1. Alternatively, or in addition, the second pressure value P2 is preferably higher than the pressure value at which the other cells, namely those which are not inflated, are inflated.

[0055] This inflating step results in the configuration schematically illustrated in figure 4B. Namely, the increased pressure in the first cells 1100 results in those cells supporting more weight than the non-inflated cells and, in particular, supporting more weight than second cells 1200. This, in turn, results in less weight being supported by the second cells 1200 and thus in a reduction of the value of the pressure within second cells 1200 to a third pressure value P3. The pressure value P3 is a function, among others, of the weight of the user lying on the anti-decubitus mattress. Thus, by measuring the pressure value P3 it is possible to deduct the weight and thus calibrate the anti-decubitus mattress accordingly.

[0056] The method 3000 therefore further comprises a measuring step S3500, in which the third pressure value P3 of the second cells 1200 is measured. Thereafter, a calibrating step S3600 is carried out for calibrating the anti-decubitus mattress 1000 based on the third pressure value P3.

[0057] The method 3000 is particularly advantageous in view of the prior art.

[0058] In particular, it does not require any computation based on an outflow of air, thus eliminating all the issues associated with the outflow valve. Moreover, it does not risk putting the user in contact with the bed's surface, such as a net or a grid, which may result in discomfort and pain for the user.

[0059] In some embodiments, the first pressure value P1 is preferably comprised between 5 and 30 Torr, more preferably between 10 and 22 Torrs. Those values ensure a safe and reliable operation of the method 3000, in particular since they avoid the weight of the user to rest on the structure underneath the anti-decubitus mattress.

[0060] In some embodiments, the second pressure value P2 is preferably comprised between 15 and 50 Torr, more preferably between 25 and 35 Torr. Those values ensure a safe and reliable operation of the method 3000, in particular by avoiding overinflating the cells, which would result in the user being supported entirely by the first cells 1100, causing pain and/or medical issues.

[0061] In some embodiments, a difference between the second pressure value P2 and the first pressure value P1 is preferably comprised between 5 and 35 Torr, more preferably between 10 and 20 Torr. Those values ensure a safe and

EP 3 753 541 B1

reliable operation of the method 3000, in particular by ensuring a sufficient different in pressure between the first cells 1100 and the second cells 1200, so as to allow the weight to be partially shifted to the first cells 1100 thus enabling a pressure reduction in the first cells and its reliable measurement.

[0062] In some embodiments, the calibrating step S3600 comprises computing a weight value of the person lying on the anti-decubitus mattress based on the third pressure value P3. In particular, the weight value W1 can be computed based on a look-up table. The following presents an example of the look-up table based on an exemplary P1 value of 15 Torr and an exemplary P2 value of 30 Torr:

P1 (Torr)	P2 (Torr)	P3 (Torr)	Weight W1 (Kg)
15	30	15	0
15	30	14	50
15	30	12	100
15	30	10	150

[0063] As it is visible in this example, by reading the value of P3 as input it is possible to derive the value of the weight W1, eventually by interpolation, if the look-up table does not have a sufficient granularity.

[0064] That is, in some embodiments, the calibrating step S3600 can comprise inputting the third pressure value P3 into a look-up table and outputting a corresponding value of the weight W1 of the anti-decubitus mattress.

[0065] In some embodiments, the look-up table can be populated by a setting step S3100, which can be preferably carried out prior to the inflating step S3200. The setting step S3100 generally allows populating of the look-up table and it will be clear to those skilled in the art that several manners can be implemented for obtaining a correspondence between the third pressure value P3 and the weight W1. For the purpose of explanation, in the following, a possible embodiment of the setting step S3100 will be described.

[0066] Figure 3B schematically illustrates a setting step S3100 for populating a look-up table according to an embodiment of the invention. The setting step S3100 can preferably take place prior to the inflating step S3300.

[0067] In particular, as can be seen in figure 3B, the setting step S3100 can comprise a step S3110 of inflating the first and second cells 1100, 1200 at a first pressure value P1, in a manner similar to step S3300. The inflating step S3110 can be carried out, with a person, a mannequin, or a similarly elongated object, having a known weight value W1 lying on the anti-decubitus mattress.

[0068] The setting step S3100 can further comprise an inflating step S3120, in which the first cells 1100 are inflated at a second pressure value P2, in a manner similar to step S3400. Also in this case, the inflating step S3120 can be carried out, with the person, the mannequin, or the similarly elongated object, having a known weight value W1 lying on the anti-decubitus mattress.

[0069] The setting step S3100 can further comprise, a step S3130 of measuring a third pressure value P3 in the second cells 1200, in a manner similar to step S3500. Moreover, the setting step S3100 can further comprise a step S3140 of populating the look-up table by assigning, in the look-up table, the known value of W1 to the measured value of P3.

[0070] The setting step S3100 thus advantageously allows creating different look-up tables for different configurations of the anti-decubitus mattress. That is, different anti-decubitus mattress made with different materials and/or different dimensions, and/or different number of cells can generate a third pressure value P3 different from each other, even though the first and second pressure values P1, P2 as well as the weight W1 are the same. The setting step S3100 described above advantageously allows generating an ad-hoc look-up table for any given configuration of the anti-decubitus mattress.

[0071] It will be clear that the setting step S3100 only needs to be carried out once for a given kind of anti-decubitus mattress. The resulting values can then be saved in a memory of a device for calibrating the anti-decubitus mattress, such as devices 5000, 6000, where the memory could be implemented by controller 5400, 6400, which will be described later in the description.

[0072] Once the weight value W1 has been obtained, for instance from the look-up table, eventually through an interpolation, the calibrating step S3600 can further comprise setting an inflating pressure of the anti-decubitus mattress at a fourth pressure value P4 and setting a deflating pressure of the anti-decubitus mattress at a fifth pressure value P5, based on the outputted weight W1.

[0073] The relationship between the weight W1 and the pressure values P4 and P5 can be obtained in several known manners, for instance based on a look up table. an exemplary look-up table is here reported for clarification:

EP 3 753 541 B1

Weight W1 (Kg)	Inflating pressure P4 (Torr)	Deflating pressure (Torr) P5
0	20	5
50	22	5
100	26	5
150	32	8

5

10 **[0074]** In addition to the known manners for populating the look-up table, the inventors have developed an inflating pressure calibrating step S3200, which will be described with reference to figure 3C.

[0075] Figure 3C schematically illustrates an inflating pressure calibrating step S3200 according to an embodiment of the invention. The inflating pressure calibrating step S3200 can preferably take place prior to the inflating step S3300. Moreover, the inflating pressure calibrating step S3200 can preferably take place after the setting step S3100.

15 **[0076]** In particular, as can be seen in figure 3C, the inflating pressure calibrating step S3200 can comprise a step S3210 of positioning a person, a mannequin, or a similarly elongated object, having a known weight value W1 on the anti-decubitus mattress.

20 **[0077]** The inflating pressure calibrating step S3200 can further comprise a step S3220 of measuring a pressure value which is generated by the weight W1 on the surface of the anti-decubitus mattress on which the weight W1 is positioned. In particular, in step S3220, an average pressure exerted by the weight W1 at the contact points between the weight W1 and the anti-decubitus mattress can be measured. The pressure value can be measured, for instance, through a measuring layer, placed between the weight and the anti-decubitus mattress. Suitable commercial products are available, for instance, from the company Xsensor.

25 **[0078]** The inflating pressure calibrating step S3200 can further comprise a step S3230 of checking whether the average contact pressure value, which has been measured at step S3220, is within a predetermined range. In particular, the range can be set in order to avoid capillary occlusion of a user of the anti-decubitus mattress. An exemplary range can have, for instance, an upper value of 35 Torr or less, preferably 32 Torr or less. In some embodiments, instead of the average contact pressure value, the maximum value of the contact pressure can be used instead.

30 **[0079]** If the measured contact pressure falls within the range, the look-up table is populated, at a populating step S325, by assigning the current value of the inflating pressure of the cells 1100, 1200 to the fourth pressure value P4. If, on the other hand, the measured contact pressure falls outside of the range, the pressure at which the cells are inflated is changed, at a step S3240, and the steps S3220 and S3230 are repeated.

35 **[0080]** This process allows identifying a value of pressure P4 which avoids capillary occlusion of a user having the weight W1 selected at step S3210. It will be clear that the step S3200 can be carried out repeatedly, with different values of weight W1, so as to populate a look-up table associating different values of W1 to different values of P4.

[0081] In some embodiments, the value of P5 will be selected, once the value of P4 is known, so as to ensure that the maximum value of the contact pressure is maintained below 32 Torr or less. This can be done, for instance, by trying different values of P5 for a given value of P4 and measuring the contact pressure as described above.

40 **[0082]** It will be clear to those skilled in the art that, in some embodiments, instead of deriving the weight value W1 from P3 and then using the weight value W1 as an input for extracting P4 and P5, as described above, it may also be possible to extract P4 and P5 directly from P3. One advantage of going through the value of W1, as described above, consists in that the extracted value of W1 can be shown to an operator of the anti-decubitus mattress, which can then more easily identify a malfunctioning than based on an indication of the measured pressure P3. This is because, for an operator, it may be difficult to judge whether P3 has a correct or wrong value, while it is much easier, particularly for medical operators, to estimate the weight of a user lying on the anti-decubitus mattress and thus identify potential malfunctioning based on the outputted value of W1.

45 **[0083]** In some additional embodiments, after the calibrating step S3600, the pressure value of the first cells 1100 and/or of the second cells 1200 can be monitored in a monitoring step, not illustrated. If the pressure value of the first cells 1100 and/or of the second cells 1200 varies outside of a predetermined range, the monitoring step can initiate a new calibration by carrying out again steps S3400, S3500 and S3600. This ensures that, if the patient moves, or the patient's weight changes for any reason, or if the patient is changed, the anti-decubitus mattress is again correctly calibrated. In some embodiments, the predetermined range can be fixed, such as, for instance +/- 5 Torr, preferably +/- 2Torr. In some embodiments, the predetermined range can be expressed as a percentage, such as, for instance +/- 20% of the monitored pressure, preferably +/- 10% of the monitored pressure. It will also be clear that, in order to avoid the re-calibration starting for every variation of the pressure, due for instance to a movement, whether the monitored pressure varies outside of the predetermined range can be determined by averaging the monitored pressure over a
55
predetermined time period, such as 10 second or more, preferably 30 seconds or more, even more preferably 60 seconds or more.

[0084] Figure 5 schematically illustrates a device 5000 for calibrating an anti-decubitus mattress according to an embodiment of the invention. Also in this case, as for the method 3000, reference will be made to the anti-decubitus mattress 1000, for explanation purposes. It will be clear, however, that any anti-decubitus mattress compatible with device 5000 can be used instead.

5 **[0085]** The device 5000 comprises a first pipe 5110 for pneumatically connecting to the first cells 1100, and a second pipe 5210 for pneumatically connecting to the second cells 1200. Here, the pipes do not need to have a specific configuration for connecting directly with the cells 1100, 1200. It will be sufficient that the pipes 5110, 5210 allow such connection, for instance through the pipes 4110, 4210, and/or through the use of appropriate adapters.

10 **[0086]** The device 5000 further comprises a first valve 5130 pneumatically connected to the first pipe 5110, and a second valve 5230 pneumatically connected to the second pipe 5210. Also in this case, the valves 5130, 5230 do not need to be directly connected to the pipes 5110, 5210, for instance since other elements can be placed in between. What is sufficient is that valves 5130, 5230 are configured such that they can open and close the access to the pipes 5110, 5210, at least on the side of the device 5000.

15 **[0087]** The device 5000 further comprises a compressor 5300 pneumatically connected to the first valve 5130 and to the second valve 5230. Also in this case, the valves 5130, 5230 do not need to be directly connected to the compressor 5300, for instance since other elements can be placed in between. What is sufficient is that valves 5130, 5230 are configured such that they can open and close the access to the pipes 5110, 5210 with respect to the compressor 5300.

[0088] It will be clear that, in alternative implementation, the compressor 5300 can be implemented by two compressors, one connected to valve 5130 and one connected to valve 5230.

20 **[0089]** The device 5000 further comprises a controller 5400 configured to control the first valve 5130, the second valve 5230 and the compressor 5300. The controller 5400 can be implemented by any appropriate electronic circuit, such as an FPGA, a purpose-built PCB, etc.

[0090] Thanks to this configuration it is possible to control the compressor 5300 so as to provide the initial pressure to both sets of cells 1100, 1200, as well as increase the pressure in one set of cells 1100, as described in method 3000.

25 **[0091]** In order for the device to also be capable of measuring the pressure in the non-inflated cells 1200, the device 5000 further comprises a pressure sensor 5240 connected to the second pipe 5210. In this case, the controller 5400 is preferably also further configured to be connected to the pressure sensor 5240, as illustrated. Thanks to this configuration, it is possible to monitor the pressure value P3 of cells 1200 as previously described. Alternatively, or in addition, as illustrated by the device 6000 of figure 6, it is possible to use the device 6000 with an anti-decubitus mattress which
30 comprises a pressure sensor 6240 pneumatically connected to the second cells 1200. In this case, the controller 6400 can be further configured to be connected to the pressure sensor 6240, for instance via an appropriate plug and/or wireless connection.

[0092] Alternatively, or in addition, a pressure sensor can be connected to the first pipe 5110, thus allowing the measurement of the pressure of first cells 1100.

35 **[0093]** Still alternatively, or in addition, a pressure sensor can be connected to the output of compressor prior to valves 5130, 5230. In this manner, by appropriately controlling valves 5130, 5230, a single pressure sensor can be used to measure the pressure in both the first cells 1100 and the second cells 1200.

[0094] Although the present invention has been described with reference to two sets of cells 1100, 1200, it will be clear that some embodiments can be implemented with more than two sets of cells.

40 **[0095]** Although the invention has been described with reference to some specific embodiments, it will be clear that the invention is not limited thereto but is defined by the claims.

List of reference numerals

45 **[0096]**

- 1000: anti-decubitus mattress
- 1100, 1200: cell
- 2000: anti-decubitus mattress
- 50 2100, 2200: cell
- 3000: method for calibrating an anti-decubitus mattress
- S3100: setting
- S3110: inflating first and second cells
- S3120: inflating first cells
- 55 S3130: measuring pressure
- S3140: populating look-up table
- S3200: calibrating inflating pressure
- S3210: positioning known weight

S3220: measuring contact pressure
 S3230: checking contact pressure
 S3240: changing inflating pressure
 S3250: populating look-up table
 5 S3300: inflating first and second cells
 S3400: inflating first cells
 S3500: measuring pressure
 S3600: calibrating
 4110, 4210: pipe
 10 5000: device for calibrating an anti-decubitus mattress
 5110, 5210: pipe
 5130, 5230: pipe
 5240: pressure sensor
 5300: compressor
 15 5400: controller
 6000: device for calibrating an anti-decubitus mattress
 6240: pressure sensor
 6400: controller
 P1, P2, P3: pressure value
 20 W1: weight value

Claims

- 25 1. Method (3000) for calibrating an anti-decubitus mattress (1000, 2000), the anti-decubitus mattress comprising a plurality of first cells (1100, 2100) and a plurality of second cells (1200, 2200), the method (3000) comprising the steps of:
- 30 inflating (S3300) the first cells (1100, 2100) and the second cells (1200, 2200) at a first pressure value (P1),
 inflating (S3400) the first cells (1100, 2100) at a second pressure value (P2),
characterized in that
 the second pressure value (P2) is higher than the first pressure value (P1),
 further **characterized by** the steps of
 35 measuring (S3500) a third pressure value (P3) of the second cells (1200, 2200),
 calibrating (S3600) the anti-decubitus mattress (1000, 2000) based on the third pressure value (P3),
 wherein the calibrating step (S3600) comprises computing a weight value (W1) based on the third pressure
 value (P3),
 wherein the weight value (W1) is computed based on a look-up table which has been previously populated to
 link a combination of the first pressure value (P1), second pressure value (P2) and third pressure value (P1) to
 40 a given weight value (W1).
2. The method according to claim 1, wherein the second pressure value (P2) is comprised between 1999 and 6666 Pascal (15 and 50 Torr), more preferably between 3333 and 4666 Pascal (25 and 35 Torr).
- 45 3. The method according to claim 1, wherein a difference between the second pressure value (P2) and the first pressure value (P1) is comprised between 666 and 4666 Pascal (5 and 35 Torr), more preferably between 1333 and 2666 Pascal (10 and 20 Torr).
- 50 4. Device (5000, 6000) for calibrating an anti-decubitus mattress (1000, 2000), the anti-decubitus mattress comprising a plurality of first cells (1100, 2100) and a plurality of second cells (1200, 2200), the device (5000) comprising:
- a first pipe (5110) for pneumatically connecting to the first cells (1100, 2100),
 a second pipe (5210) for pneumatically connecting to the second cells (1200, 2200),
 a first valve (5130) pneumatically connected to the first pipe (5110),
 55 a second valve (5230) pneumatically connected to the second pipe (5210),
 a compressor (5300) pneumatically connected to the first valve (5130) and to the second valve (5230),
 a controller (5400, 6400) configured to control the first valve (5130), the second valve (5230) and the compressor (5300), and

a pressure sensor (5240, 6240) pneumatically connected to the second pipe (5210) or pneumatically connected to the second cells (1200, 2200) together with a pressure sensor pneumatically connected to the first pipe (5110) or pneumatically connected to the first cells (1100), and/or a pressure sensor pneumatically connected to an output of the compressor (5300) prior to the first valve (5130) and to the second valve (5230), wherein the controller (6400) is further configured to be connected to the pressure sensor (5240, 6240), the controller (5400, 6400) being configured to carry out the steps of

inflating (S3300) the first cells (1100, 2100) and the second cells (1200, 2200) at a first pressure value (P1), inflating (S3400) the first cells (1100, 2100) at a second pressure value (P2), higher than the first pressure value (P1), measuring (S3500) a third pressure value (P3) of the second cells (1200, 2200), calibrating (S3600) the anti-decubitus mattress (1000, 2000) based on the third pressure value (P3) wherein the calibrating step (S3600) comprises computing a weight value (W1) based on the third pressure value (P3), wherein the weight value (W1) is computed based on a look-up table which has been previously populated to link a combination of the first pressure value (P1), second pressure value (P2) and third pressure value (P1) to a given weight value (W1).

20 Patentansprüche

1. Verfahren (3000) zum Kalibrieren einer Anti-Dekubitus-Matratze (1000, 2000), wobei die Anti-Dekubitus-Matratze eine Vielzahl von ersten Zellen (1100, 2100) und eine Vielzahl von zweiten Zellen (1200, 2200) umfasst, wobei das Verfahren (3000) die Schritte umfasst:

Aufblasen (S3300) der ersten Zellen (1100, 2100) und der zweiten Zellen (1200, 2200) auf einen ersten Druckwert (P1),

Aufblasen (S3400) der ersten Zellen (1100, 2100) auf einen zweiten Druckwert (P2),

dadurch gekennzeichnet, dass

der zweite Druckwert (P2) höher ist als der erste Druckwert (P1),

darüber hinaus **gekennzeichnet durch** die Schritte

Messen (S3500) eines dritten Druckwertes (P3) der zweiten Zellen (1200, 2200),

Kalibrieren (S3600) der Anti-Dekubitus-Matratze (1000, 2000) auf der Grundlage des dritten Druckwertes (P3), wobei der Kalibrierungsschritt (S3600) ein Berechnen eines Gewichtswertes (W1) auf der Grundlage des dritten Druckwertes (P3) umfasst,

wobei der Gewichtswert (W1) auf der Grundlage einer Nachschlagetabelle berechnet wird, die zuvor ausgefüllt wurde, um eine Kombination aus dem ersten Druckwert (P1), dem zweiten Druckwert (P2) und dem dritten Druckwert (P1) mit einem gegebenen Gewichtswert (W1) zu verknüpfen.

2. Verfahren nach Anspruch 1, wobei der zweite Druckwert (P2) zwischen 1999 und 6666 Pascal (15 und 50 Torr), vorzugsweise zwischen 3333 und 4666 Pascal (25 und 35 Torr), liegt.

3. Verfahren nach Anspruch 1, wobei eine Differenz zwischen dem zweiten Druckwert (P2) und dem ersten Druckwert (P1) zwischen 666 und 4666 Pascal (5 und 35 Torr), vorzugsweise zwischen 1333 und 2666 Pascal (10 und 20 Torr), liegt.

4. Einrichtung (5000, 6000) zum Kalibrieren einer Anti-Dekubitus-Matratze (1000, 2000), wobei die Anti-Dekubitus-Matratze eine Vielzahl von ersten Zellen (1100, 2100) und eine Vielzahl von zweiten Zellen (1200, 2200) umfasst, wobei die Einrichtung (5000) umfasst:

eine erste Leitung (5110) zum pneumatischen Verbinden mit den ersten Zellen (1100, 2100),

eine zweite Leitung (5210) zum pneumatischen Verbinden mit den zweiten Zellen (1200, 2200),

ein erstes Ventil (5130), das pneumatisch mit der ersten Leitung (5110) verbunden ist,

ein zweites Ventil (5230), das pneumatisch mit der zweiten Leitung (5210) verbunden ist,

einen Kompressor (5300), der pneumatisch mit dem ersten Ventil (5130) und mit dem zweiten Ventil (5230) verbunden ist,

eine Steuerung (5400, 6400), die ausgestaltet ist, um das erste Ventil (5130), das zweite Ventil (5230) und den Kompressor (5300) zu steuern, und

EP 3 753 541 B1

einen Drucksensor (5240, 6240), der pneumatisch mit der zweiten Leitung (5210) oder pneumatisch mit den zweiten Zellen (1200, 2200) verbunden ist, zusammen mit einem Drucksensor, der pneumatisch mit der ersten Leitung (5110) oder pneumatisch mit den ersten Zellen (1100) verbunden ist, und/oder einen Drucksensor, der pneumatisch mit einem Ausgang des Kompressors (5300) vor dem ersten Ventil (5130) und dem zweiten Ventil (5230) verbunden ist, wobei die Steuerung (6400) darüber hinaus ausgestaltet ist, um mit dem Drucksensor (5240, 6240) verbunden zu sein,

wobei die Steuerung (5400, 6400) ausgestaltet ist, um die Schritte auszuführen Aufblasen (S3300) der ersten Zellen (1100, 2100) und der zweiten Zellen (1200, 2200) auf einen ersten Druckwert (P1),

Aufblasen (S3400) der ersten Zellen (1100, 2100) auf einen zweiten Druckwert (P2), der höher ist als der erste Druckwert (P1),

Messen (S3500) eines dritten Druckwerts (P3) der zweiten Zellen (1200, 2200), Kalibrieren (S3600) der Anti-Dekubitus-Matratze (1000, 2000) basierend auf dem dritten Druckwert (P3),

wobei der Kalibrierungsschritt (S3600) ein Berechnen eines Gewichtswerts (W1) auf der Grundlage des dritten Druckwerts (P3) umfasst,

wobei der Gewichtswert (W1) auf der Grundlage einer Nachschlagetabelle berechnet wird, die zuvor ausgefüllt wurde, um eine Kombination aus dem ersten Druckwert (P1), dem zweiten Druckwert (P2) und dem dritten Druckwert (P1) mit einem gegebenen Gewichtswert (W1) zu verknüpfen.

20 Revendications

1. Procédé (3000) permettant de calibrer un matelas anti-escarres (1000, 2000), le matelas anti-escarres comprenant une pluralité de premières alvéoles (1100, 2100) et une pluralité de secondes alvéoles (1200, 2200), le procédé (3000) comprenant les étapes consistant à :

gonfler (S3300) les premières alvéoles (1100, 2100) et les secondes alvéoles (1200, 2200) à une première valeur de pression (P1),

gonfler (S3400) les premières alvéoles (1100, 2100) à une deuxième valeur de pression (P2),

caractérisé en ce que

la deuxième valeur de pression (P2) est supérieure à la première valeur de pression (P1),

caractérisé en outre par les étapes consistant à

mesurer (S3500) une troisième valeur de pression (P3) des secondes alvéoles (1200, 2200),

calibrer (S3600) le matelas anti-escarres (1000, 2000) en fonction de la troisième valeur de pression (P3),

l'étape de calibrage (S3600) comprenant le calcul d'une valeur de poids (W1) en fonction de la troisième valeur de pression (P3),

la valeur de poids (W1) étant calculée en fonction d'une table de consultation qui a été précédemment remplie pour relier une combinaison de la première valeur de pression (P1), de la deuxième valeur de pression (P2) et de la troisième valeur de pression (P1) à une valeur de poids donnée (W1).

2. Procédé selon la revendication 1, dans lequel la deuxième valeur de pression (P2) est comprise entre 1999 et 6666 Pascal (15 et 50 Torr), plus préférablement entre 3333 et 4666 Pascal (25 et 35 Torr).

3. Procédé selon la revendication 1, dans lequel une différence entre la deuxième valeur de pression (P2) et la première valeur de pression (P1) est comprise entre 666 et 4666 Pascal (5 et 35 Torr), plus préférablement entre 1333 et 2666 Pascal (10 et 20 Torr).

4. Dispositif (5000, 6000) permettant de calibrer un matelas anti-escarres (1000, 2000), le matelas anti-escarres comprenant une pluralité de premières alvéoles (1100, 2100) et une pluralité de secondes alvéoles (1200, 2200), le dispositif (5000) comprenant :

un premier tuyau (5110) permettant de se raccorder pneumatiquement aux premières alvéoles (1100, 2100),

un second tuyau (5210) permettant de se raccorder pneumatiquement aux secondes alvéoles (1200, 2200),

une première soupape (5130) raccordée pneumatiquement au premier tuyau (5110),

une seconde soupape (5230) raccordée pneumatiquement au second tuyau (5210),

un compresseur (5300) raccordé pneumatiquement à la première soupape (5130) et à la seconde soupape (5230),

un organe de commande (5400, 6400) configuré pour commander la première soupape (5130), la seconde soupape (5230) et le compresseur (5300), et

EP 3 753 541 B1

un capteur de pression (5240, 6240) raccordé pneumatiquement au second tuyau (5210) ou raccordé pneumatiquement aux secondes alvéoles (1200, 2200) conjointement avec un capteur de pression raccordé pneumatiquement au premier tuyau (5110) ou raccordé pneumatiquement aux premières alvéoles (1100), et/ou un capteur de pression raccordé pneumatiquement à une sortie du compresseur (5300) avant la première soupape (5130) et la seconde soupape (5230), l'organe de commande (6400) étant configuré en outre pour être raccordé au capteur de pression (5240, 6240),

l'organe de commande (5400, 6400) étant configuré pour effectuer les étapes consistant à gonfler (S3300) les premières alvéoles (1100, 2100) et les secondes alvéoles (1200, 2200) à une première valeur de pression (P1),

gonfler (S3400) les premières alvéoles (1100, 2100) à une deuxième valeur de pression (P2), supérieure à la première valeur de pression (P1),

mesurer (S3500) une troisième valeur de pression (P3) des secondes alvéoles (1200, 2200),

calibrer (S3600) le matelas anti-escarres (1000, 2000) en fonction de la troisième valeur de pression (P3)

l'étape de calibrage (S3600) comprenant le calcul d'une valeur de poids (W1) en fonction de la troisième valeur de pression (P3),

la valeur de poids (W1) étant calculée en fonction d'une table de consultation qui a été précédemment remplie pour relier une combinaison de la première valeur de pression (P1), de la deuxième valeur de pression (P2) et de la troisième valeur de pression (P1) à une valeur de poids donnée (W1).

Fig. 1A

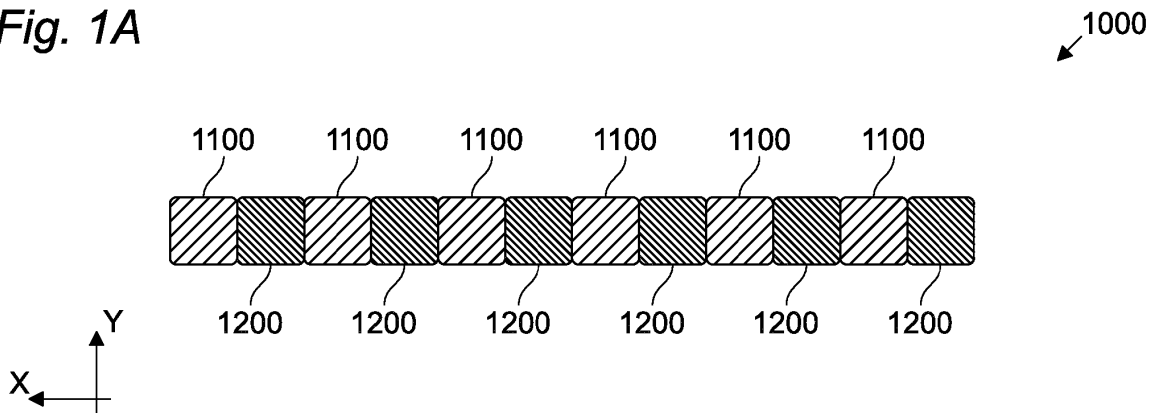

Fig. 1B

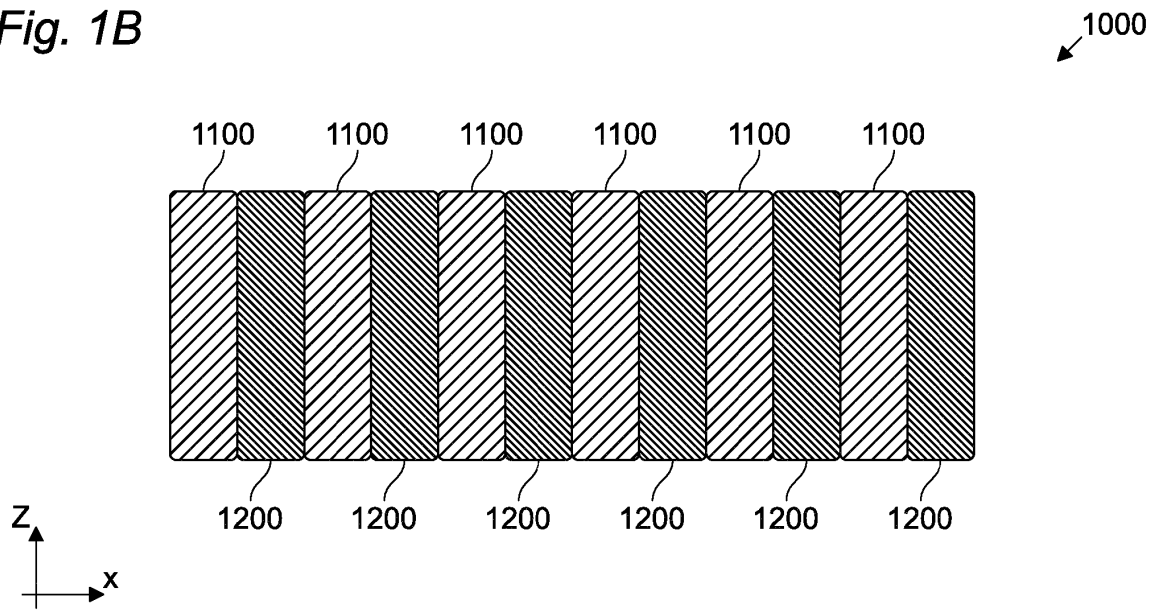

Fig. 2

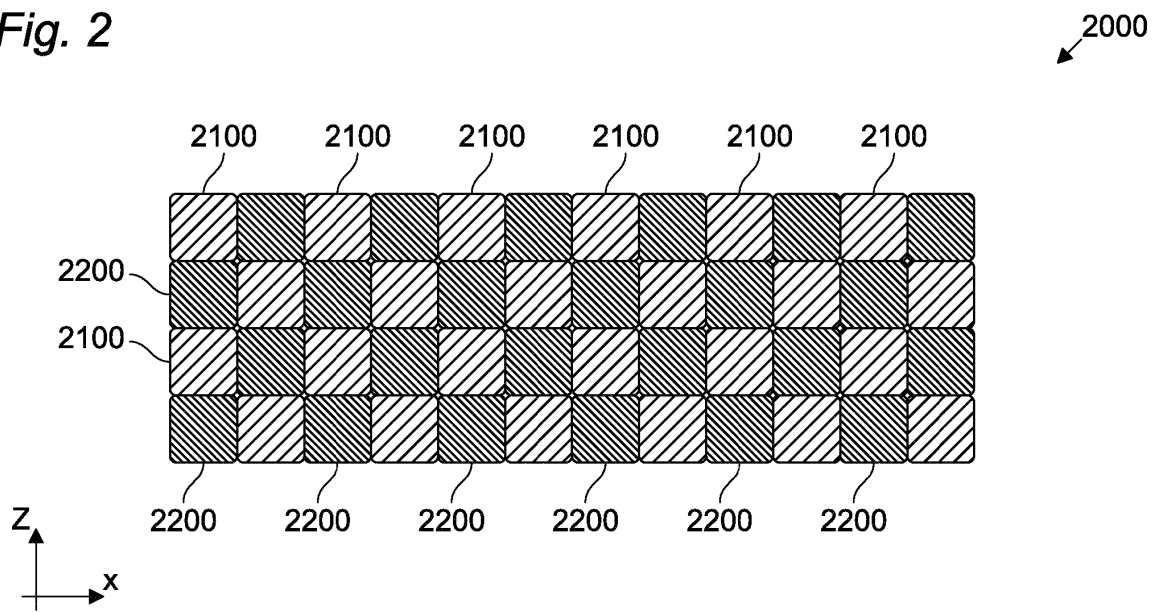

Fig. 3A

3000

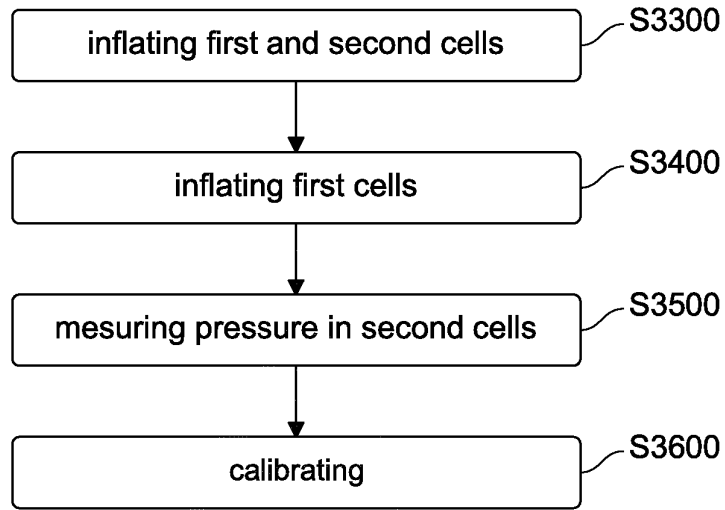

Fig. 3B

S3100

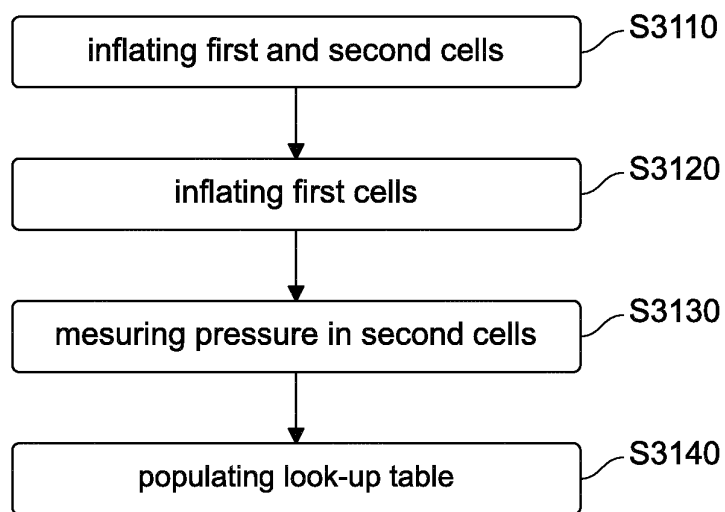

Fig. 3C

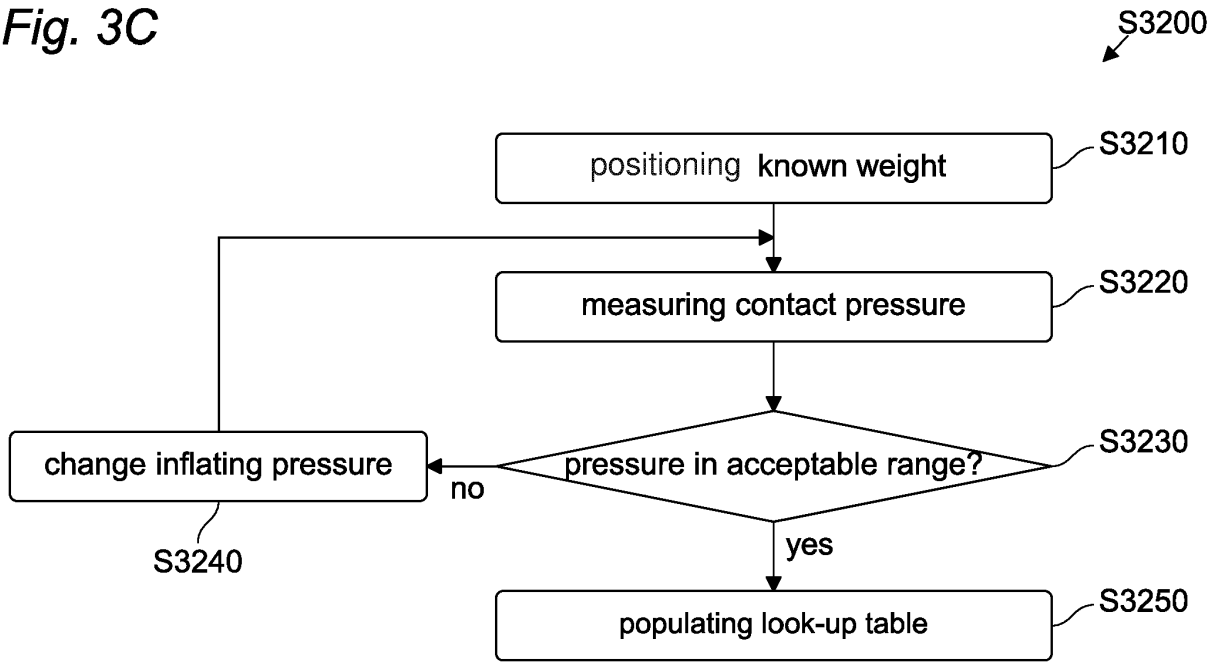

Fig. 4A

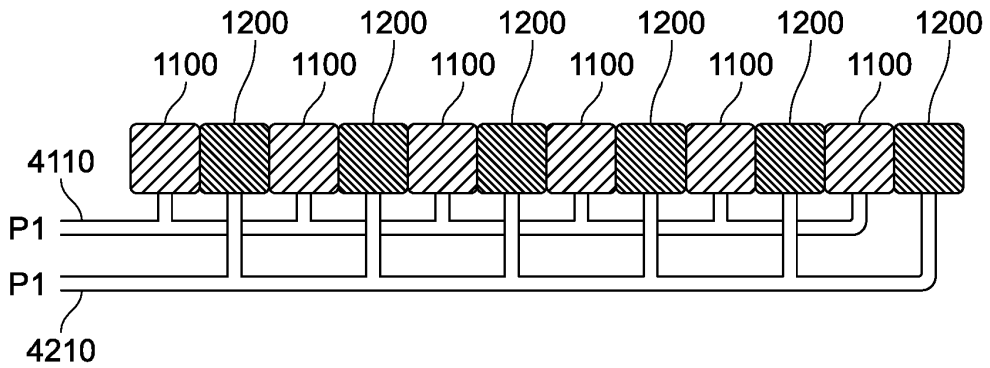

Fig. 4B

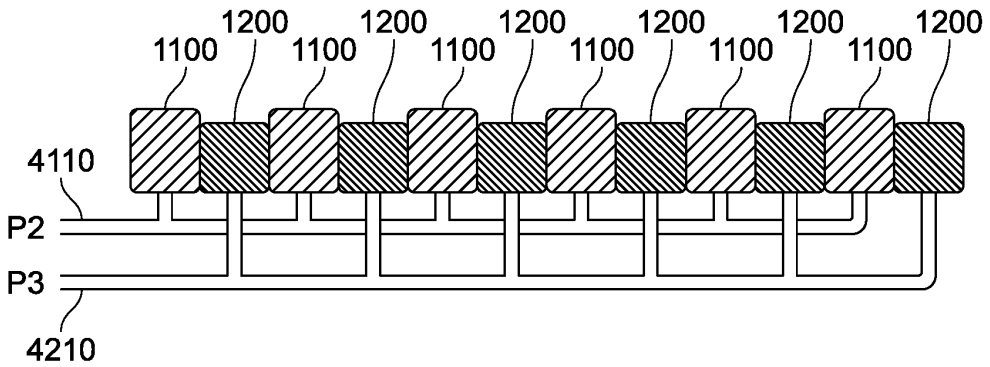

Fig. 5

5000

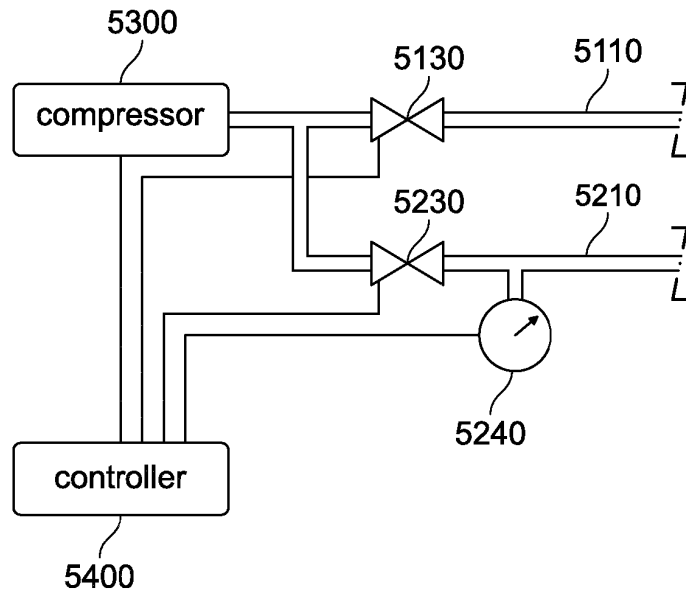
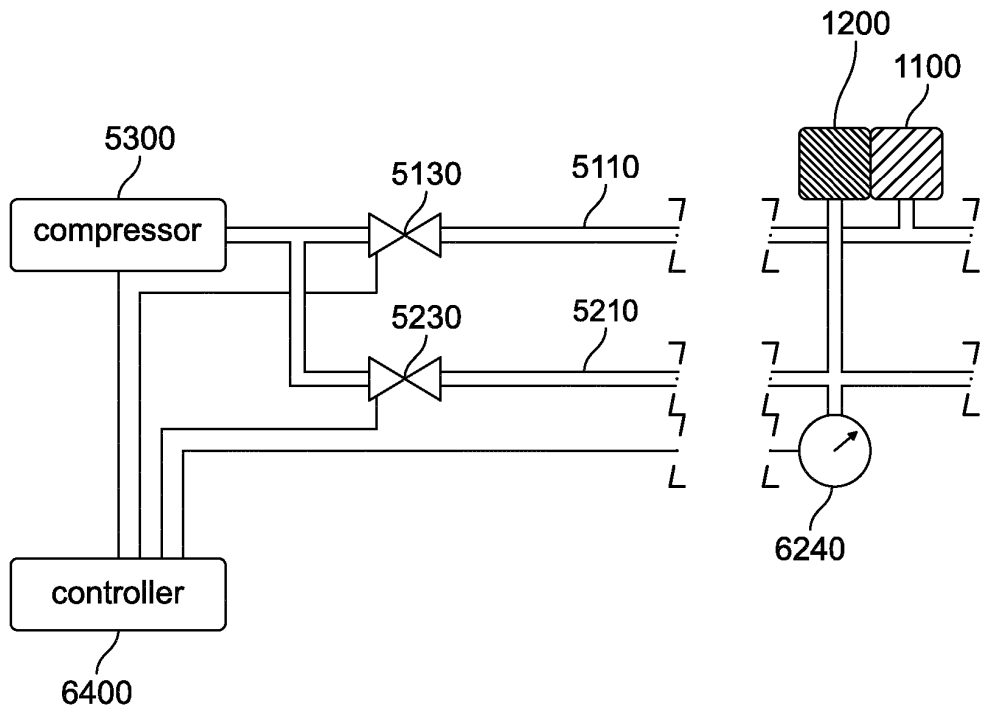

Fig. 6

6000



REFERENCES CITED IN THE DESCRIPTION

This list of references cited by the applicant is for the reader's convenience only. It does not form part of the European patent document. Even though great care has been taken in compiling the references, errors or omissions cannot be excluded and the EPO disclaims all liability in this regard.

Patent documents cited in the description

- WO 2015132560 A1 [0026]
- US 20050091752 A1 [0026]