

(19) **DANMARK**

(10) **DK/EP 3965616 T5**



Patent- og
Varemærkestyrelsen

(12) **Rettet oversættelse af
europæisk patentskrift**

-
- (51) Int.Cl.: **A 47 C 1/0355 (2013.01)**
- (45) Oversættelsen bekendtgjort den: **2023-11-20**
- (80) Dato for Den Europæiske Patentmyndigheds bekendtgørelse om meddelelse af patentet: **2023-05-31**
- (86) Europæisk ansøgning nr.: **20750573.6**
- (86) Europæisk indleveringsdag: **2020-06-28**
- (87) Den europæiske ansøgnings publiceringsdag: **2022-03-16**
- (86) International ansøgning nr.: **DE2020100559**
- (87) Internationalt publikationsnr.: **WO2021000993**
- (30) Prioritet: **2019-06-29 DE 102019117623**
- (84) Designerede stater: **AL AT BE BG CH CY CZ DE DK EE ES FI FR GB GR HR HU IE IS IT LI LT LU LV MC MK MT NL NO PL PT RO RS SE SI SK SM TR**
- (73) Patenthaver: **M. Schuster Patentverwertungs GmbH, Bonner Straße 12, 51379 Leverkusen, Tyskland**
- (72) Opfinder: **Schuster, Michael, Hågewiesen 120, 30657 Hannover, Tyskland**
- (74) Fuldmægtig i Danmark: **CHAS. HUDE A/S, Langebrogade 3B, 1411 København K, Danmark**
- (54) Benævnelse: **Siddemøbel med wall-away-funktion og udsvingbar foddel**
- (56) Fremdragne publikationer:
US-A- 3 493 264
US-A1- 2015 272 329

SEATING FURNITURE HAVING A WALL-AWAY FUNCTION AND A FOOT PART THAT CAN BE PIVOTED OUT

The invention relates to a piece of seating furniture, comprising a chassis, a seat part
5 which can be pivoted in inclination, a back part which can be pivoted relative to the seat
part, and a foot part, which can be pivoted out and is connected to the seat part via at least
one foot part adjustment mechanism, wherein to adjust the piece of seating furniture from
an upright sitting position into a reclining position the seat part is displaced forwards
relative to the chassis, wherein, in the sitting position, the foot part is pivoted in
10 substantially below the seat part and, in the reclining position, it is pivoted out in front of
the seat part in such a way that the seat part is extended by the foot part.

In particular, the present invention relates to pieces of seating furniture of this type in
which the backrest can be pivoted without a wall and which are therefore also colloquially
15 referred to as sofas with a wall-away function. This means that during pivoting into a
reclining position the backrest moves forwards together with the seat part relative to the
chassis, in such a way that the backrest does not protrude or only slightly protrudes
beyond the rear edge of the piece of seating furniture in each pivoting position.

20 DE202016104352U1 and US020150272329A1 (Fig. 10, 11) disclose pieces of seating
furniture which, in addition to a wall-away function of this type, also have a floor-free
construction having a foot part, which is pivoted in below the seat part approximately
parallel, and having a slim design in the front seat region. US3493264 A discloses a
generic piece of seating furniture.

25

Furthermore, in the aforementioned pieces of seating furniture, the seat part, the back part
and the foot part can be adjusted by means of linear actuators.

30 However, the drawback of the pieces of seating furniture known from the cited
publications is that in every case a relatively short footrest is used, which is pivoted in
below the seat part approximately parallel, meaning that when the footrest is in the
pivoted-out position the user's feet protrude beyond the front edge of the foot part and

therefore have no support surface, in such a way that the reclining comfort for the user is limited.

Starting from the described prior art, the object of the invention is to develop a piece of seating furniture of the generic type in such a way that, with the use of one or more linear actuators to adjust the seat part, back part and foot part, the reclining comfort of the piece of seating furniture is improved.

To increase the reclining comfort of a piece of seating furniture according to the invention, a footrest much longer than in the pieces of seating furniture known from publications DE202016104352U1 and US020150272329A1 is to be implemented, which is pivoted in below the seat part approximately parallel, in such a way that, when the foot part is pivoted out, a complete contact surface for the feet of the user is guaranteed.

The adjustment mechanism used to pivot the foot part should be designed compactly, in such a way that a slim design of the piece of seating furniture is possible in the front seat region and the foot part can be arranged below the lowest point of the adjustment mechanism.

The stated object is achieved according to the invention by a piece of seating furniture, having a wall-away function and a foot part which can be pivoted out, with the features set out in claim 1.

As a result of a lever geometry according to the invention of the foot part adjustment mechanism, in combination with an arrangement according to the invention of the linear actuator for the seat part/foot part adjustment, a significantly longer footrest, pivoted in below the seat part approximately parallel, can be used for the foot part than in the pieces of seating furniture known from the prior art, because

- during a first phase of the pivoting of the piece of seating furniture from the sitting into the reclining position, the footrest is guided closer to the seat part and with a “flatter” movement curve than in the known pieces of seating furniture, and,

- to increase the distance between the front edge of the seat part and the contact plane of the pieces of seating furniture, the inclination of the seat part is always adjusted first, and only then is the foot part extended.

5 As a result, according to the invention, a reclining length of the pivoted-out foot part is achieved such that a complete support surface for the user's feet is ensured.

An embodiment of the invention is described below with reference to the accompanying drawings, in which:

10

Fig. 1 shows a piece of seating furniture according to the invention in the sitting position of the piece of seating furniture;

15

Fig. 2 shows a piece of seating furniture according to the invention in accordance with Fig. 1 from a different perspective;

Fig. 3 shows a piece of seating furniture according to the invention in a first intermediate position;

20

Fig. 4 shows a piece of seating furniture according to the invention in accordance with Fig. 3 from a different perspective.

25

Fig. 5 is a detailed view of a piece of seating furniture according to the invention in accordance with Fig. 3;

Fig. 6 shows a piece of seating furniture according to the invention in accordance with Fig. 3 with a partially pivoted foot part;

30

Fig. 7 shows a piece of seating furniture according to the invention in a second intermediate position;

Fig. 8 shows a piece of furniture according to the invention in the reclining position of the piece of furniture.

Fig. 9 is a detailed view of the foot part adjustment mechanism of a piece of seating furniture according to the invention in accordance with Fig. 7.

The drawings substantially only show the mechanism of the piece of seating furniture 1 according to the invention, without the parts which are not of relevance here, such as in particular upholstery.

Some of the components mentioned below are duplicated as a result of a largely mirror-image construction of the mechanism of the piece of seating furniture 1, these components in each case being discussed in the singular below, this meaning both components in each case.

A piece of seating furniture 1 according to the invention consists of a chassis 5, a seat part 3, a back part 4 which is connected to the seat part 3 and/or the chassis 5 via at least one back part adjustment mechanism 2, and a foot part 6 which can be pivoted out, the piece of seating furniture 1 being pivotable between a sitting position, shown in Fig. 1, and a reclining position, shown in Fig. 8.

The foot part 6 is connected to the seat part 3 via at least one foot part adjustment mechanism 9 in the form of at least five four-bar chains arranged in succession.

The foot part 6 is formed in two parts, the foot part 6 comprising a first footrest 6b fastened to a first foot part fitting 6a and a second footrest 6d fastened to a second foot part fitting 6c, the first foot part fitting 6a and second foot part fitting 6c being coupled to one another in such a way that the first footrest 6b fastened to the first foot part fitting 6a can be pivoted from the sitting position, in which the second footrest 6d fastened to the second foot part fitting 6c preferably forms a front panel and the first footrest 6b is pivoted in below the seat part 3, into the reclining position, in which the second footrest 6d forms, together with the first footrest 6b, an extension of the seat part 3 adjoining the seat part 3,

the first footrest 6b being pivoted into an approximately horizontal position extending the end of the pivoted-out second footrest 6d remote from the seat part 3.

5 In the pivoted-in position, the first footrest 6b is arranged at least in part below the lowest point of the footrest adjustment mechanism 9 and preferably approximately parallel to the seat part 3.

The foot part adjustment mechanism 9 of the piece of seating furniture 1 according to the invention comprises five four-bar chains arranged in succession, a first 10 and/or a second 10 11 articulated lever being articulated to the seat part 3 in the sitting position of the seat and a longitudinal axis formed between the two end articulation points 18, 19 of at least one of the first 10 and/or second 11 articulated lever being arranged oblique to the seat part 3, and the end articulation point 18 of this articulated lever which faces the seat part 3 being closer than the end articulation point 19 of this articulated lever remote from the 15 seat part 3 to a vertical plane defined by the front edge 23 of the seat part, whilst, in the sitting position of the piece of seating furniture 1, a third 12 and fourth 13 articulated lever have an orientation in which a longitudinal axis formed between the two end articulation points 20, 21 of at least one of the third 12 and/or fourth 13 articulated lever is arranged oblique to the seat part 3, and the end articulation point 21 of this articulated 20 lever remote from the seat part 3 is closer than the end articulation point 20 of this articulated lever which faces the seat part 3 to a vertical plane defined by the front edge 23 of the seat part.

The terms “the end articulation point which faces the seat part” and “the end articulation 25 point remote from the seat part” each mean the shortest distance between an end articulation point of an articulated lever and the seat part, an end articulation point of an articulated lever which faces the seat part being at a shorter distance from the seat part than an end articulation point of this articulated lever remote from the seat part.

30 At least one of the first 10 and/or second 11 articulated lever has a stop element 41 which, during the pivoting movement of the foot part 6, comes into contact with a stop surface of a seat part bracket 42 connected to the front region of the seat part 3 (Fig. 5).

A fifth 14 and sixth 15 articulated lever are each articulated to the third 12 and/or fourth 13 articulated lever, and at least one of the fifth 14 and/or sixth 15 articulated lever is articulated to the second foot part fitting 6c and forms a four-bar chain together with the first 6a and second foot part fitting 6c and a connecting lever 37.

A coupling lever 16 is articulated to the first 10 and second 11 articulated lever and to the third 12 and fourth 13 articulated lever.

10 A control lever 17 is articulated both to the first 10 or second 11 articulated lever and to the third 12 or fourth 13 articulated lever.

In an arrangement of the articulated, coupling and control levers 10, 11, 12, 13, 14, 15, 16, 17 which is particularly preferred according to the invention, the first 10 and second 11 articulated lever are each articulated to a front region of the seat part 3 and each to the coupling lever 16, the third 12 and fourth 13 articulated lever are each articulated to the coupling lever 16 and, by their end articulation points 20, 22 which face the seat part 3 in the sitting position of the piece of seating furniture 1, each to the sixth articulated lever 15, the sixth articulated lever 15 is also articulated to the second foot part fitting 6c, one of the third 12 and/or fourth 13 articulated lever is extended beyond its point of articulation to the coupling lever 16 and is articulated at its free end to a first end of the control lever 17, the second end of which is articulated to a central region of one of the first 10 and/or second 11 articulated lever, the third articulated lever 12, in the sitting position of the piece of seating furniture 1, is positioned closer than the fourth articulated lever 13 to a vertical plane defined by the front edge 23 of the seat part, and the fifth articulated lever 14 is articulated to a central region of the third articulated lever 12 and to the second foot part fitting 6c (Fig. 6 and Fig. 9).

In this context, “a central region of the articulated lever” does not mean the exact geometric centre, but rather the entire region of an articulated lever between the two end articulation points.

The first 6a and second foot part fitting 6c are preferably pivotably interconnected, and the fifth 14 and sixth 15 articulated lever are articulated at a distance from one another to the second foot part fitting 6c, one of the articulated levers 14, 15 being extended beyond the region of its articulation point to the second foot part fitting 6c, and being articulated
5 at its free end to the first end of the connecting lever 37, the second end of which is articulated to the first foot part fitting 6a (Fig. 9).

During the adjustment of the piece of seating furniture 1 from the sitting into the reclining position, the first 10 and/or second 11 articulated lever are pivoted in such a way that the
10 coupling lever 16 is pushed forwards relative to the seat part 3, the third 12 and fourth 13 articulated lever simultaneously being pivoted relative to the coupling lever 16, and the first 6a and second foot part fitting 6c being pushed forwards relative to the coupling lever 16.

15 As a result of the arrangement according to the invention and the cumulative pivoting movements of the first 10 and/or second 11 articulated lever and the third 12 and/or fourth 13 articulated lever, in which, during the adjustment of the piece of seating furniture 1 from the sitting into the reclining position, according to the invention one of the first 10 and/or second 11 articulated lever is pivoted through an angle of preferably more than
20 200° relative to one of the third 12 and/or fourth 13 articulated lever, a large displacement path for the foot part 6 is achieved overall.

According to the invention, the first 10 and/or second 11 articulated lever and the third 12 and/or fourth 13 articulated lever are arranged in such a way that, during approximately
25 the first half of the adjustment of the foot part 6 from the pivoted sitting position into the pivoted reclining position, the coupling lever 16 is lowered relative to the seat part 3, all portions of the fifth 14 and/or sixth 15 articulated lever and an articulation point 30 of one of the fifth 14 and/or sixth 15 articulated lever to the second foot part fitting 6c being raised relative to the coupling lever 16.

30

The lowering of the coupling lever 16 is thus approximately compensated for by a simultaneous lifting of the fifth 14 and/or sixth 15 articulated lever as well as the first 6a

and second foot part fitting 6c relative to the coupling lever 16, and this, in connection with a pivoting movement of the second foot part fitting 6c towards the seat part 3, has the effect that the front edge 43 of the first footrest 6b follows an almost linear or a “flat” movement curve close to the seat part front edge 23 during a first phase of pivoting from the sitting into the reclining position, the movement curve of the articulation point 40 of the first foot part fitting 6a to the second foot part fitting 6c having a rising progression, with respect to a horizontal plane defined by this articulation point 40 in the sitting position of the piece of seating furniture 1, throughout the pivoting of the foot part 6 from the sitting into the reclining position.

The inventive effect of a “flat” movement curve of the front edge 43 of the first footrest 6b (Fig. 6) enables the use of a much longer first footrest 6b than in the known, generic seating furniture (see DE202016104352U1 and US020150272329A1), in such a way that, in combination with the aforementioned large displacement path of the foot part 6, a particularly long leg support surface according to the invention can be made available in the pivoted-out position of the foot part 6.

During approximately the second half of the adjustment of the foot part 6 from the pivoted-in sitting position into the pivoted-out reclining position, the coupling lever 16 is raised relative to the seat part 3, the articulation point 30 of one of the fifth 14 and/or sixth 15 articulated lever to the second foot part fitting 6c simultaneously being lowered relative to the coupling lever 16. As a result, the foot part adjustment mechanism 9 is stretched out in such a way that a continuous upholstery covering, extending over the seat part 3 and foot part 6 and not shown in the drawings, is tightened when the foot part 6 is in the pivoted-out position.

According to the invention, the arrangement of the sixth articulated lever 15 and of its articulation points 20a, 22a, 30 to the third 12 and fourth 13 articulated lever and to the second foot part fitting 6c is of decisive importance for the desired functional sequence and for a particularly compact construction according to the invention of the foot part adjustment mechanism 9.

The sixth articulated lever 15 particularly preferably has a width of approximately 40-70 mm, the articulation points 20a, 22a of the third 12 and fourth 13 articulated lever to the sixth articulated lever 15 on the longitudinal face of the sixth articulated lever 15 which faces the seat part 3, as well as the articulation point 30 of the second foot part fitting 6c to the sixth articulated lever 15, being positioned on the longitudinal face of the sixth articulated lever 15 remote from the seat part 3 in the sitting position of the piece of seating furniture 1.

As a result, the sixth articulated lever 15 forms, together with the third 12 and fifth 14 articulated lever and the second foot part fitting 6c, a four-bar chain 33, 34, 35, 36, which crosses over itself according to the invention and in which an imaginary straight connecting line 34 through the articulation points 31, 32 of the fifth articulated lever 14 to the third articulated lever 12 and second foot part fitting 6c and an imaginary straight connecting line 35 through the articulation points 20a, 30 of the sixth articulated lever 15 to the third articulated lever 12 and second foot part fitting 6c cross over (Fig. 9).

As a result of the crossing straight lines of action or straight connecting lines 34, 35, the pivoting of the second foot part fitting 6c is provided in the desired form according to the invention, and a particularly compact design according to the invention of the foot part adjustment mechanism 9 is made possible, in which at least three four-bar chains of the foot part adjustment mechanism 9, in the pivoted-in position, are on approximately the same level as the sixth articulated lever 15, in such a way that the installation space required below the seat part 3 for the foot part adjustment mechanism 9 is not much more than the width of the sixth articulated lever 15, and the first footrest 6b can be arranged below the lowest point of the footrest adjustment mechanism 9 (Fig. 3).

Furthermore, as a result of the sixth articulated lever 15, when the piece of seating furniture is viewed from the side in the reclining position of the piece of seating furniture 1, at least one of the third 12 and/or fourth 13 articulated lever, the fifth articulated lever 14, the second foot part fitting 6c and at least a sub-region of the coupling lever 16 is largely covered by the sixth articulated lever 15, in such a way that the viewer can only

perceive a linear structure of a lever plate extending flat below the seat part 3 and the foot part 6.

5 The footrest adjustment mechanism 9 is actuated by a first linear actuator 28, which is preferably coupled to the first 10 or second 11 articulated lever.

10 The five four-bar chains of the foot part adjustment mechanism 9, which are arranged in succession, are coupled to one another in such a way that the generation of a sub-stroke at the first linear actuator 28 causes the first 10 and/or second 11 articulated lever to pivot and thus, during the pivoting of the piece of seating furniture 1 between the sitting and the reclining position, causes the first footrest 6b to pivot in or out through an angle of preferably 150° to 180°.

15 The back part adjustment mechanism 2 has a fastening plate 51, which is rigidly connected to the seat part 3 and has a pivot lever 48 articulated thereto, and which is also connected to the chassis 5 via a first connecting lever 39 and to the back part 4 via a second connecting lever 38.

20 The seat part 3 can be displaced relative to the chassis 5, by means of a first 24 and second displacement unit 25, from a sitting position displaced towards the rear edge of the piece of seating furniture 1 into a reclining position displaced towards the front edge of the piece of seating furniture 1, and adjusted in inclination.

25 The terms “front edge of the seat” and “rear edge of the seat” refer to the perspective of a person sitting on the seat with his legs pointing forwards and his back pointing backwards.

30 The first displacement unit 24 has a pivot guide, a front 7 and a rear link lever 8 forming, together with the seat part 3 and an intermediate carrier 26 connected to the second displacement unit 25, a four-bar chain (Fig. 2).

The pivoting movement of the first displacement unit 24 towards the front edge of the piece of seating furniture 1 is blocked by a stop element 27 on the seat part side (Fig. 5).

5 The second displacement unit 25 is formed by a linear or approximately linear guide system, preferably by at least one linear guide 44, in the form of a rack-and-pinion gear having gear wheels 46 which can be moved along a rack-and-pinion segment 45, or by a lever adjustment mechanism, the guide system being movable, starting from the sitting position of the piece of seating furniture 1, forwards relative to the chassis 5 along a movement path, the movement path preferably being linear and/or the movement path
10 rising in the forwards direction (Fig. 4).

The first 24 and second 25 displacement unit are attached to one another, the intermediate carrier 26 being connected to the gear wheels 46 of the linear guide 44, and the linear guide 44 further being connected to the rack segment 45 on the chassis 5, resulting in the
15 first displacement unit 24 being slidably guided relative to the chassis 5.

The first displacement unit 24 is subjected to a force by a tension spring 47 (Fig. 2, 4).

20 The tension spring 47 is preferably coupled to the seat part 3 and also preferably coupled to the intermediate carrier 26 of the first displacement unit 24.

The first linear actuator 28 is coupled to the first displacement unit 24 at a first end, via a first transverse strut 49 connected to the intermediate support 26 of the first displacement unit 24, and to the foot part adjustment mechanism 9 at a second end, via a second
25 transverse strut 50 connected to the foot part adjustment mechanism 9 (Fig. 2).

According to the invention, the first transverse strut 49 is guided displaceably both relative to the chassis 5 and relative to the seat part 3.

30 A second linear actuator 29 is coupled to the chassis 5 at a first end and to the first transverse strut 49 at a second end (Fig. 2).

This arrangement according to the invention of the first 28 and the second linear actuator 29, in which

- 5 - the first linear actuator 28 is coupled to the first transverse strut 49, which is guided displaceably both relative to the chassis 5 and relative to the seat part 3, at a first end, and to the foot part adjustment mechanism 9 at a second end, via the second transverse strut 50 connected to the foot part adjustment mechanism 9, and
- 10 - the second linear actuator 29 is coupled to the chassis 5 at a first end and to the first transverse strut 49, which is guided displaceably both relative to the chassis 5 and relative to the seat part 3, at a second end,

enables an advantageous adjustment process, described below, of the seat part 3, the foot part 6 and the back part 4 between the sitting and the reclining position of a piece of seating furniture 1 according to the invention.

15

In a piece of seating furniture 1 according to the present invention, in the starting position or sitting position of the piece of seating furniture 1, the second linear actuator 29, which is articulated between the chassis 5 and the first transverse strut 49, holds the second displacement unit 25 in its starting position; moreover, the first linear actuator 28, acting
20 between the first 49 and second transverse strut 50, holds the foot part 6 in the pivoted-in end position by means of the stop element 41, which acts between the seat part bracket 42 and the foot part adjustment mechanism 9, and the first displacement unit 24 is defined in its pivoting position as a result of the defined position of the foot part 6 and by means of the first linear actuator 28 (Fig. 1, 2).

25

When actuated, the first linear actuator 28 generates a linear stroke consisting of at least a first and second sub-stroke, the seat part 3 being slid forwards by means of the first displacement unit 24 in a first adjustment step of the piece of seating furniture 1 from the sitting into the reclining position brought about by the first sub-stroke of the first linear
30 actuator 28, and the rear region of the seat part 3 being lowered and the front region of the seat part 3 being raised, in such a way that the seat part 3 is adjusted in inclination relative to the sitting position of the piece of seating furniture 1 until the rear link lever 8

of the first displacement unit 24 comes into contact with a stop element 27 on the seat part side and the pivoting movement of the first displacement unit 24 is thereby blocked.

5 In this first intermediate position of the piece of seating furniture 1, also referred to as the “lounging position”, the foot part 6 is not yet extended (Fig. 3, 4, 5).

The tension spring 47 shortens during this first adjustment step and thereby assists in the adjustment movement of the seat part 3, resulting in the seat part 3 being adjusted first without the foot part 6 pivoting relative to the seat part 3 (Fig. 3, 4, 5).

10

In a second adjustment step of the piece of seating furniture 1 from the sitting into the reclining position, brought about by the second sub-stroke of the first linear actuator 28, while the tilting and displacement position of the seat part 3 relative to the chassis 5 achieved at the end of the first sub-stroke is maintained and the position of the back part 4 relative to the seat part 3 is maintained, an extension of the foot part 6 relative to the seat part 3 is brought about until the foot part 6 has reached the pivoted-out end position and thus a second intermediate position, also known as the “relaxation position” (Fig. 7).

20 As a result of this adjustment process – in which, when the first linear actuator 28 is actuated in the adjustment direction towards the reclining position of the piece of seating furniture 1, to increase the distance between the front edge 23 of the seat part and the contact plane of the piece of seating furniture 1, the inclination of the seat part 3 is always adjusted first and then the foot part 6 is extended – a greater pivoting space may for example be made available for the extending foot part 6 than in the sitting position of the piece of seating furniture 1, making it possible to use a longer first footrest 6b.

25

In combination with the above-described lever geometry according to the invention of the foot part adjustment mechanism 9 for a long leg support surface in the pivoted-out position of the foot part 6, this achieves a reclining length of the pivoted-out foot part 6 such that the object of providing a piece of seating furniture of the generic type with a complete support surface for the user’s feet has thus been solved according to the invention.

30

In the opposite direction of adjustment, in other words towards the sitting position of the piece of seating furniture 1, when the first linear actuator 28 is actuated, as a result of the spring force of the tension spring 47 which is to be overcome, the foot part 6 is first
5 retracted until the stop element 41 comes into contact with the stop surface of the seat part bracket 42, and then the seat part 3 is adjusted into the starting position counter to the spring force of the tension spring 47.

A linear stroke generated by actuation of the second linear actuator 29 brings about a third
10 adjustment step of the piece of seating furniture 1 from the sitting into the reclining position, the seat part 3, during this adjustment step, being displaced forwards relative to the chassis 5 by means of the linear guide 44, and the back part 4 being pivoted relative to the seat part 3 without any problems in a manner coupled to the sliding movement of the seat part 3 (Fig. 8).

15

All the aforementioned adjustment steps brought about by the first 28 and second linear actuator 29 may be carried out separately and in any order or else, if appropriate, simultaneously, an adjustment of the back part 4 and foot part 6 which can be actuated mutually independently and an adjustment of the back part 4 and seat part 3 which can be
20 actuated mutually independently being guaranteed, in such a way that, in every adjustment position of the seat part 3 or foot part 6, the back part 4 can be adjusted into any desired pivoting position without any problems, and, in every adjustment position of the back part 4, the seat part 3 or foot part 6 can be pivoted into any desired position.

25 The invention is not limited to the example embodiment, but rather can be varied in numerous ways within the scope of the disclosure.

All individual and combination features disclosed in the description and/or drawings are regarded as essential to the invention.

30

PATENTKRAV

1. Siddemøbel (1) med et chassis (5), en sædedel (3), hvis hældning svingbart kan bevæges, en rygdæl (4) og en foddæl (6), som kan svinges ud og er forbundet til sædedelen (3) via mindst eet foddæl-justeringsdrev (9),

- hvorved siddemøblet (1) kan justeres mellem en siddeposition og en liggeposition,
- hvorved, i det mindste i en delfase for justeringen af siddemøblet (1) fra sidde- til liggepositionen, sædedelen (3) skubbes fremad i forhold til chassiset (5),
- hvorved, i siddepositionen, foddælen (6) er svinget i det væsentlige nedenunder sædedelen (3), og, i liggepositionen, foddælen (6) på en sådan måde er svinget ud foran sædedelen (3), at sædedelen (3) forlænges ved hjælp af foddælen (6),
- hvorved, i siddepositionen for siddemøblet (1), en første fodstøtte (6b), som er fastgjort til et første foddælbeslag (6a) på foddælen (6), er arrangeret skråt eller parallelt i forhold til sædedelen (3) og derved indeslutter en vinkel på fortrinsvis 60° til 90° i forhold til et vertikalt plan, der defineres af en forkant (23) på sædedelen,
- hvorved, i siddepositionen for siddemøblet (1), en første (10) og/eller en anden (11) leddelt arm er ledforbundet til sædedelen (3), og en længdeakse, som er dannet mellem de to ende-ledpunkter (18, 19) på mindst én af den første (10) og/eller den anden (11) leddelte arm er arrangeret skråt i forhold til sædedelen (3), og ende-ledpunktet (18) på denne leddelte arm, som vender mod sædedelen (3), er nærmere end ende-ledpunktet (19) på denne leddelte arm distalt fra sædedelen (3) i forhold til et vertikalt plan, der defineres af sædedelens forkant (23),
- hvorved, i siddepositionen for siddemøblet (1), en tredje (12) og en fjerde (13) leddelt arm har en orientering, i hvilken en længdeakse, der er dannet mellem de to ende-ledpunkter (20, 21) på mindst én af den tredje (12) og/eller fjerde (13) leddelte-arm, er arrangeret skråt i forhold til sædedelen (3), og ende-ledpunktet (21) på denne leddelte arm, di-

stalt for sædedelen (3), er nærmere end ende-ledpunktet (20) på denne leddelte arm, som vender mod sædedelen (3), i forhold til et vertikalt plan, der defineres af sædedelens forkant (23),

5 - hvorved henholdsvis en femte (14) og en sjette (15) leddelt arm hver er ledforbundet til den tredje (12) og/eller den fjerde (13) leddelte arm, og mindst én af den femte (14) og/eller den sjette (15) leddelte arm er ledforbundet til et andet foddelbeslag (6c), der er koblet til det første foddelbeslag (6a) og danner en fire-leds-kæde sammen med det første (6a) og det andet (6c) foddelbeslag samt en forbindelsesarm (37),

10 - hvorved den tredje (12) og den fjerde (13) leddelte arm er forbundet ved hjælp af ende-ledpunkterne (20, 22) derfor, som vender mod sædedelen (3) i siddepositionen for siddemøblet (1), henholdsvis til den femte (14) eller den sjette leddelte arm (15),

15 - en koblingsarm (17) er ledforbundet til den første (10) eller til den anden (11) leddelte arm og til den tredje (12) eller fjerde (13) leddelte arm,

- en koblingsarm (16) er ledforbundet til den første (10) og/eller den anden (11) og/eller til den tredje (12) og/eller fjerde (13) leddelte arm,

20 - hvorved, under en delfase af justeringen af siddemøblet (1) fra siddepositionen til liggepositionen, koblingsarmen (16) sænkes i forhold til sædedelen (3), hvorved ledpunktet (30) for en af den femte (14) og/eller sjette (15) leddelte arm til det andet foddelbeslag (6c) samtidig løftes i forhold til koblingsarmen (16),

25 - hvorved mindst en første (28) og fortrinsvis en anden (29) lineær aktuator er tilvejebragt til at justere sædedelen (3), foddelen (6) og rygdelen (4) mellem sidde- og liggepositionen for siddemøblet (1),

- hvorved den første lineære aktuator (28) ved aktivering frembringer et lineært slag, som består af mindst et første og et andet del-slag,

30 - hvorved den første lineære aktuator (28), under justeringen af siddemøblet (1) fra sidde- til liggepositionen, bevirker, ved hjælp af et første del-slag, en fremadforskydning af sædedelen (3) i forhold til chassiset (5) og en samtidig hældningsjustering af sædedelen (3), hvorved der under dette første del-slag af den første lineære aktuator (28) ingen ud-

ad- eller indadgående bevægelse af foddelen (6) i forhold til sædedelen (3) sker,

- hvorved den første lineære aktuator (28) under justeringen af siddemøblet (1) fra sidde- til liggepositionen fortrinsvis bevirker, ved hjælp af et andet del-slag efterfølgende det første del-slag, en udad-bevægelse af foddelen (6) i forhold til sædedelen (3).

2. Siddemøbel (1) ifølge krav 1,

- kendetegnet ved, at**, i siddepositionen for siddemøblet (1), den første fodstøtte (6b) er arrangeret som skrå eller parallel med sædedelen (3) og indeslutter en vinkel på 60° til 90° i forhold til et vertikalt plan, der er defineret af sædedelens forkant (23).

3. Siddemøbel (1) ifølge enten krav 1 eller krav 2,

- kendetegnet ved, at** den første fodstøtte (6b) svinges gennem en vinkel på 150° til 180° under justeringen af siddemøblet (1) fra sidde- til liggepositionen.

4. Siddemøbel (1) ifølge mindst eet af de foregående krav,

kendetegnet ved, at

20

- det første (6a) og det andet (6c) foddelbeslag svingbart er forbundet med hinanden,

- den femte (14) og sjette (15) leddelte arm med en indbyrdes afstand er ledforbundet til det andet foddelbeslag (6c),

25

- hvorved en af den femte (14) og/eller sjette (15) leddelte arm er forlænget ud over området med dens ledpunkt til det andet foddelbeslag (6c) og ved dens frie ende er ledforbundet til den første ende af forbindelsesarmen (37), hvis anden ende er ledforbundet til det første foddelbeslag (6a).

30

5. Siddemøbel (1) ifølge mindst et af de foregående krav,

kendetegnet ved, at

- 5 - under en del-fase af justeringen af siddemøblet (1) fra sidde- til liggepositionen, koblingsarmen (16) sænkes i forhold til sædedelen (3), hvorved ledpunktet (30) for en af den femte (14) og/eller sjette (15) leddelte arm for det andet foddelbeslag (6c) samtidig løftes i forhold til koblingsarmen (16), og
- 10 - under en yderligere del-fase af justeringen af siddemøblet (1) fra sidde- til liggepositionen, koblingsarmen (16) løftes i forhold til sædedelen (3), hvorved ledpunktet (30) for en af den femte (14) og/eller sjette (15) leddelte arm til det andet foddelbeslag (6c) samtidig sænkes i forhold til koblingsarmen (16).

6. Siddemøbel (1) ifølge mindst eet af de foregående krav,
kendetegnet ved, at, under justeringen af siddemøblet (1) fra sidde- til liggepositionen, en af den første (10) og/eller den anden (14) leddelte arm i en svingbevægelse bevæges i forhold til en af den tredje (12) og/eller fjerde (13) leddelte arm, gennem en vinkel på mindst 150°, fortrinsvis gennem en vinkel på mere end 200°.

7. Siddemøbel (1) ifølge mindst eet af de foregående krav,
20 **kendetegnet ved, at** den første (10) og den anden (11) leddelte arm dels hver for sig er ledforbundet til et frontområde af sædedelen (3) og dels hver for sig er koblet til koblingsarmen (16), den tredje (12) og den fjerde (13) leddelte arm dels hver for sig er ledforbundet til koblingsarmen (16) og dels hver for sig til den sjette leddelte arm (15), hvorved en af den tredje (12) og/eller den fjerde
25 (13) leddelte arm er forlænget ud over dens ledpunkt på koblingsarmen (16) og dels hver for sig på dens frie ende er forbundet til en første ende af styrearmen (17), hvis anden ende er ledforbundet til et midterområde af en af den første (10) og/eller anden (11) leddelte arm, og den tredje leddelte arm (12), i siddepositionen for siddemøblet (1), er positioneret nærmere end den fjerde leddelte
30 arm (13) til et vertikalt plan, som er defineret af forkanten (23) på sædedelen, og den femte leddelte arm (14) er ledforbundet til et midterområde af den tredje leddelte arm (12) og til det andet foddelbeslag (6c).

8. Siddemøbel (1) ifølge mindst eet af de foregående krav,
kendetegnet ved, at forkanten (43) af den første fodstøtte (6b) følger en flad bevægelseskurve, nær ved forkanten (23) af sædedelen under en første fase af svingbevægelsen fra siddepositionen til liggepositionen, og bevægelseskurven for ledpunktet (40) i det første foddelsbeslag (6a) til det andet foddelsbeslag (6c) strækker sig på stigende måde i forhold til et horisontalt plan, der er defineret af ledpunktet (40) i siddepositionen for siddemøblet (1) gennem hele svingbevægelsen for foddelen (6) fra siddepositionen til liggepositionen.
- 10 9. Siddemøbel (1) ifølge mindst eet af de foregående krav,
kendetegnet ved, at foddelen (6) omfatter en første fodstøtte (6b), som er fastgjort til det første foddelsbeslag (6a), og en anden fodstøtte (6d), der er fastgjort til det andet foddelsbeslag (6c), hvorved det første (6a) og det andet foddelsbeslag (6c) er koblet til hinanden på en sådan måde, at den første fodstøtte (6b), som er fastgjort til det første foddelsbeslag (6a), kan bevæges fra siddepositionen, i hvilken den anden fodstøtte (6d), der er fastgjort til det andet foddelsbeslag (6c), fortrinsvis danner et frontpanel, og den første fodstøtte (6b) svingbart bevæges, fortrinsvis i det væsentlige parallelt, neden under sædedelen (3), ind i hvilepositionen, i hvilken den anden fodstøtte (6d), sammen med den første fodstøtte (6b), danner en forlængelse af sædedelen (3), og som støder op til sædedelen (3), hvorved den første fodstøtte (6b) svinges ind i en cirka horisontal position, der forlænger en ende af den udsvingede anden fodstøtte (6d), bort fra sædedelen (3).
- 25 10. Siddemøbel (1) ifølge mindst eet af de foregående krav,
kendetegnet ved, at den femte (14) og den sjette (15) leddelte arm, sammen med dels den tredje (12) eller den fjerde (13) leddelte arm og dels det andet foddelsbeslag (6c), danner en krydsende fire-leds-kæde (33, 34, 35, 36), i hvilken en imaginær forbindelseslinje (34), der passerer gennem ledpunkterne (31, 32) i den femte leddelte arm (14) på dels den tredje (12) eller fjerde (13) leddelte arm og dels til det andet foddelsbeslag (6c), og en imaginær forbindelseslinje (35), der passerer gennem ledpunkterne (20a, 30) i den sjette leddelte arm (15)

til den tredje (12) eller fjerde (13) leddelte arm og til det andet foddelsbeslag (6c), krydser hinanden.

11. Siddemøbel (1) ifølge mindst eet af de foregående krav,

- 5 **kendetegnet ved, at** den første lineære aktuator (28) under justeringen af siddemøblet (1) fra sidde- til liggepositionen bevirker, ved hjælp af det andet delslag, som efterfølger det første delslag for den første lineære aktuator (28), en forlængelse af foddelen (6) i forhold til sædedelen (3).

10 12. Siddemøbel (1) ifølge mindst eet af de foregående krav,

- kendetegnet ved, at** den første lineære aktuator (28) under justeringen af siddemøblet (1) fra sidde- til liggepositionen, ved hjælp af et andet delslag, som efterfølger det første delslag af den første lineære aktuator (28), mens der opretholdes hældnings- og forskydningspositionen for sædedelen (3) i forhold til chassiset (5), og som opnås ved afslutningen af det første delslag, og mens der opretholdes positionen af rygdelen (4) i forhold til sædedelen (3), bevirker en forlængelse af foddelen (6) i forhold til sædedelen (3).

13. Siddemøbel (1) ifølge mindst eet af de foregående krav,

20 **kendetegnet ved, at**

- en første (28) og en anden (29) lineær aktuator er tilvejebragt for at justere sædedelen (3), foddelen (6) og rygdelen (4) mellem sidde- og liggepositionen for siddemøblet (1),
- hvorved den første lineære aktuator (28) ved aktivering frembringer et lineært slag, som består af mindst et første og et andet delslag,
- hvorved den første lineære aktuator (28) under justeringen af siddemøblet (1) fra sidde- til liggepositionen bevirker, ved hjælp af et første delslag, en forskydning fremad af sædedelen (3) i forhold til chassiset (5) og en samtidig hældningsjustering af sædedelen (3), ingen forlængelse eller tilbagetrækning af foddelen (6) i forhold til sædedelen (3), forekommende under det første delslag af den første lineære aktuator (28), og

- hvorved den første lineære aktuator, ved hjælp af et andet delslag efterfølgende det første delslag af den første lineære aktuator (28), bevirker en udadbevægelse af foddelen (6) i forhold til sædedelen (3),
- hvorved, under justeringen af siddemøblet (1) fra sidde- til liggepositionen, den anden lineære aktuator (29) ved aktivering genererer et lineært slag, og således, mens der opretholdes positionen af foddelen (6) i forhold til sædedelen (3), bevirker en fremadforskydning af sædedelen (3) i forhold til chassiset (5), hvorved der samtidig med forskydningsbevægelsen af sædedelen (3) i forhold til chassiset (5) sker en svingbevægelse, koblet dertil, af rygdelen (4) i forhold til sædedelen (3).

14. Siddemøbel (1) ifølge mindst eet af de foregående krav,

kendetegnet ved, at

- sædedelen (3) forskydes i forhold til chassiset (5) via en første (24) og anden (25) forskydningsenhed for at justere siddemøblet (1) mellem sidde- og liggepositionen,
- den første forskydningsenhed (24) er fastgjort til sædedelen (3) og til den anden forskydningsenhed (25), og den anden forskydningsenhed (25) ydermere er fastgjort til chassiset (5),
- den første forskydningsenhed (24) er ført forskydeligt i forhold til chassiset (5).

15. Siddemøbel (1) ifølge mindst eet af de foregående krav,

kendetegnet ved, at

- den første forskydningsenhed (24) omfatter en svingføring, en forreste (7) og en bageste (8) leddelt arm, der danner en fire-leds-kæde sammen med sædedelen (3) og en mellemliggende understøtning (26), der er forbundet til den anden forskydningsenhed 25,
- svingbevægelsen af den første forskydningsenhed (24) hen imod forkanten af siddemøblet (1) blokeres af et anslagselement (27) på sædedelsiden.

16. Siddemøbel (1) ifølge mindst eet af de foregående krav,
kendetegnet ved, at den anden forskydningsenhed (25) er dannet ved hjælp af et lineært eller med tilnærmelse lineært føringssystem, fortrinsvis ved hjælp af mindst én lineær føring (44) i form af et tandstangsdrev eller ved hjælp af en
- 5 armjusteringsmekanisme, og føringssystemet, udgående fra sædepositionen for siddemøblet (1), kan bevæges fremad langs en bevægelsesbane i forhold til chassiset (5), hvorved bevægelsesbanen fortrinsvis er stigende i retning fremad.
- 10 17. Siddemøbel (1) ifølge mindst eet af de foregående krav,
kendetegnet ved, at den første forskydningsenhed (24) kraft-påvirkes ved hjælp af mindst én trækfjeder (47), og trækfjederen (47) er fortrinsvis koblet til sædedelen (3) og fortrinsvis koblet til den mellemliggende understøtning (26) i den første forskydningsenhed (24).
- 15 18. Siddemøbel (1) ifølge mindst eet af de foregående krav,
kendetegnet ved, at den anden lineære aktuator (29) med en første ende er koblet til chassiset (5), og med en anden ende til den første forskydningsenhed (24) via en første tværgående stiver (49) forbundet til den mellemliggende stiver
- 20 (26) i den første forskydningsenhed (24).
19. Siddemøbel (1) ifølge mindst eet af de foregående krav,
kendetegnet ved, at den første lineære aktuator (28) med en første ende er koblet til den første forskydningsenhed (24), via den første tværstiver (49) forbundet til den mellemliggende understøtning (26) i den første forskydningsenhed (24), og med en anden ende forbundet til foddel-justeringsmekanismen (9) via en anden tværgående stiver (50), som er forbundet til foddel-justeringsmekanismen (9).
- 25 20. Siddemøbel (1) ifølge mindst eet af de foregående krav,
kendetegnet ved, at den første tværstiver (49) er ført forskydeligt i forhold til chassiset (5) og i forhold til sædedelen (3).
- 30

21. Siddemøbel (1) ifølge mindst eet af de foregående krav,

kendetegnet ved, at

- 5 - den anden lineære aktuator (29) med en første ende er koblet til chassiset (5) og med en anden ende er koblet til den første tværstiver (49), der er ført forskydeligt i forhold til chassiset (5) og i forhold til sædedelen (3), og
- 10 - den første lineære aktuator (28) med en første ende er koblet til den første tværstiver (49), som forskydeligt er ført i forhold til chassiset (5) og i forhold til sædedelen (3), og med en anden ende er koblet til foddeljusteringsmekanismen (9), via en anden tværstiver (50), der er forbundet til foddeljusteringsmekanismen (9).

22. Siddemøbel (1) ifølge mindst eet af de foregående krav,

- kendetegnet ved, at,** under justeringen af siddemøblet (1) fra ligge- til siddeposition,

- 20 - en svingbevægelse af foddelen (6), bevirket af det første del-slag af den første lineære aktuator (28), blokeres af et anslagselement (41), og
- ved frembringelse af et andet del-slag, efterfølgende det første del-slag af den første lineære aktuator (28), der bevirkes en forskydning bagud af sædedelen (3) i forhold til chassiset (5) og en samtidig hældningsjustering af sædedelen (3).

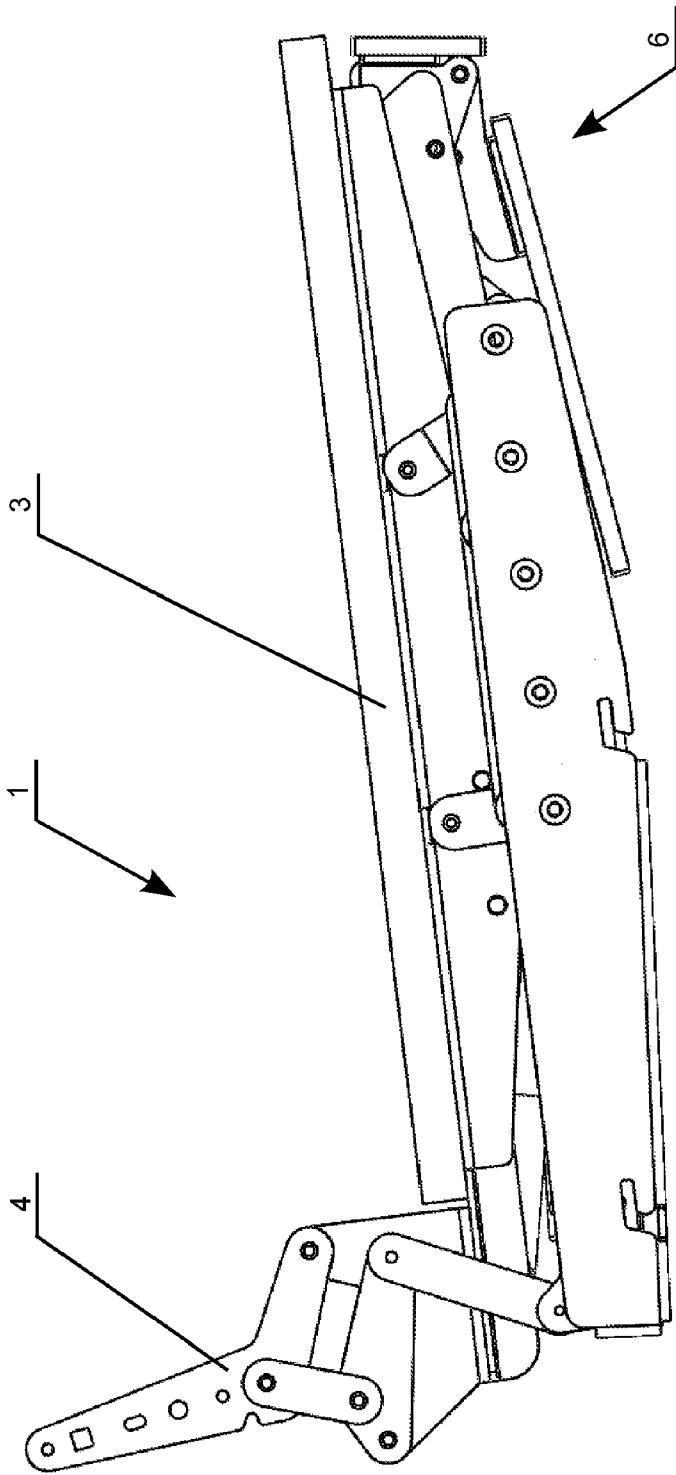

Fig. 1

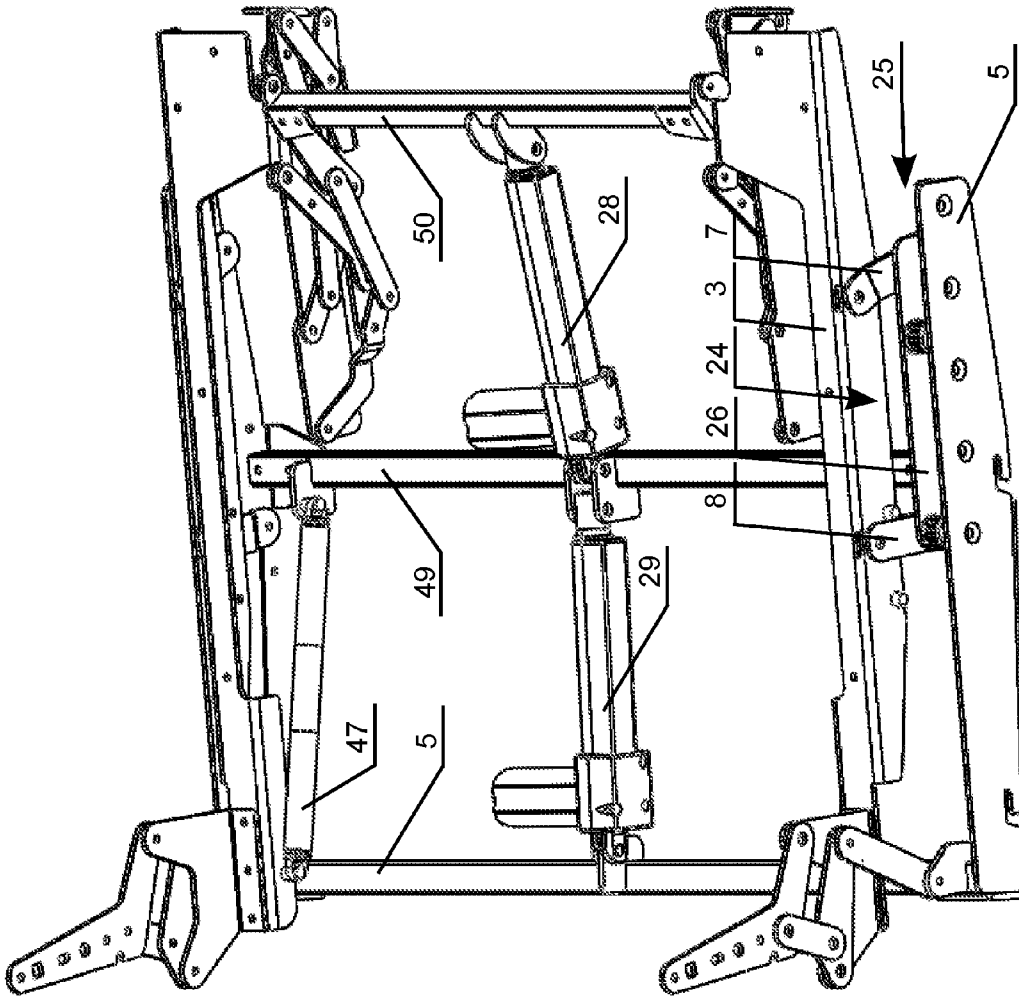

Fig. 2

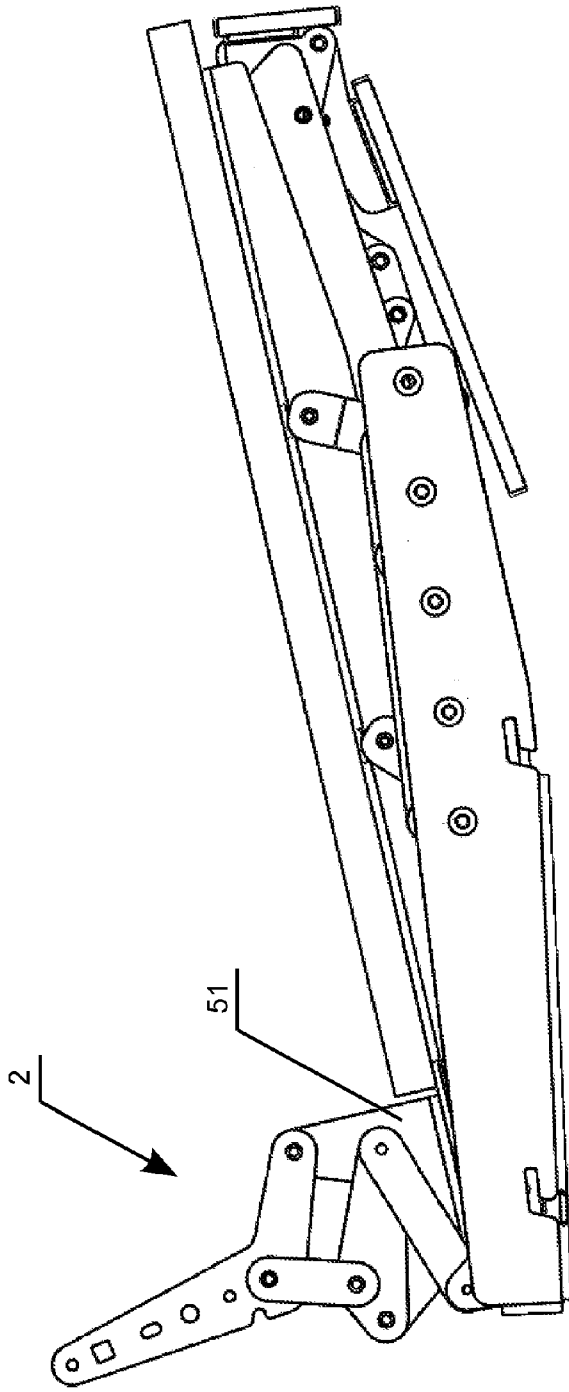

Fig. 3

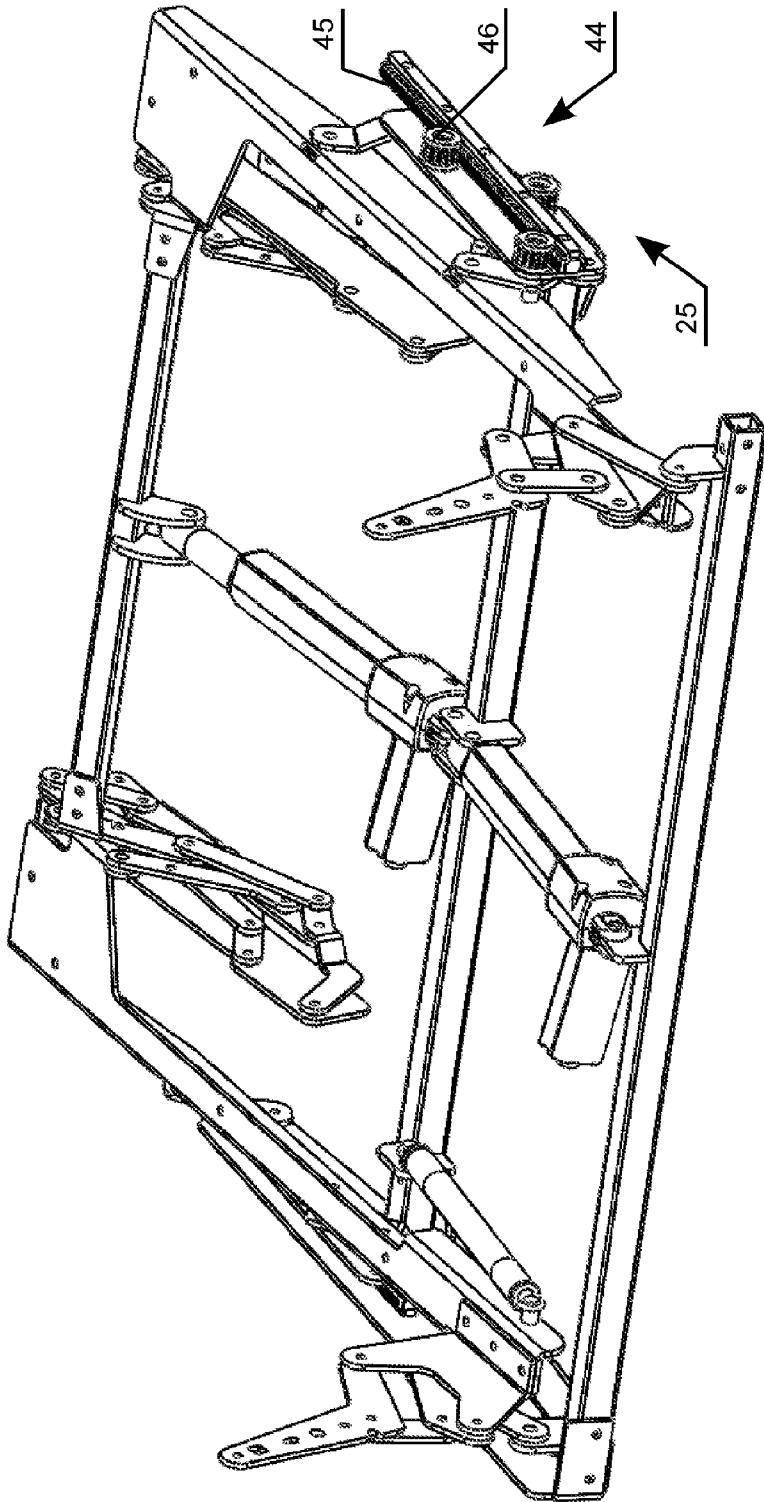

Fig. 4

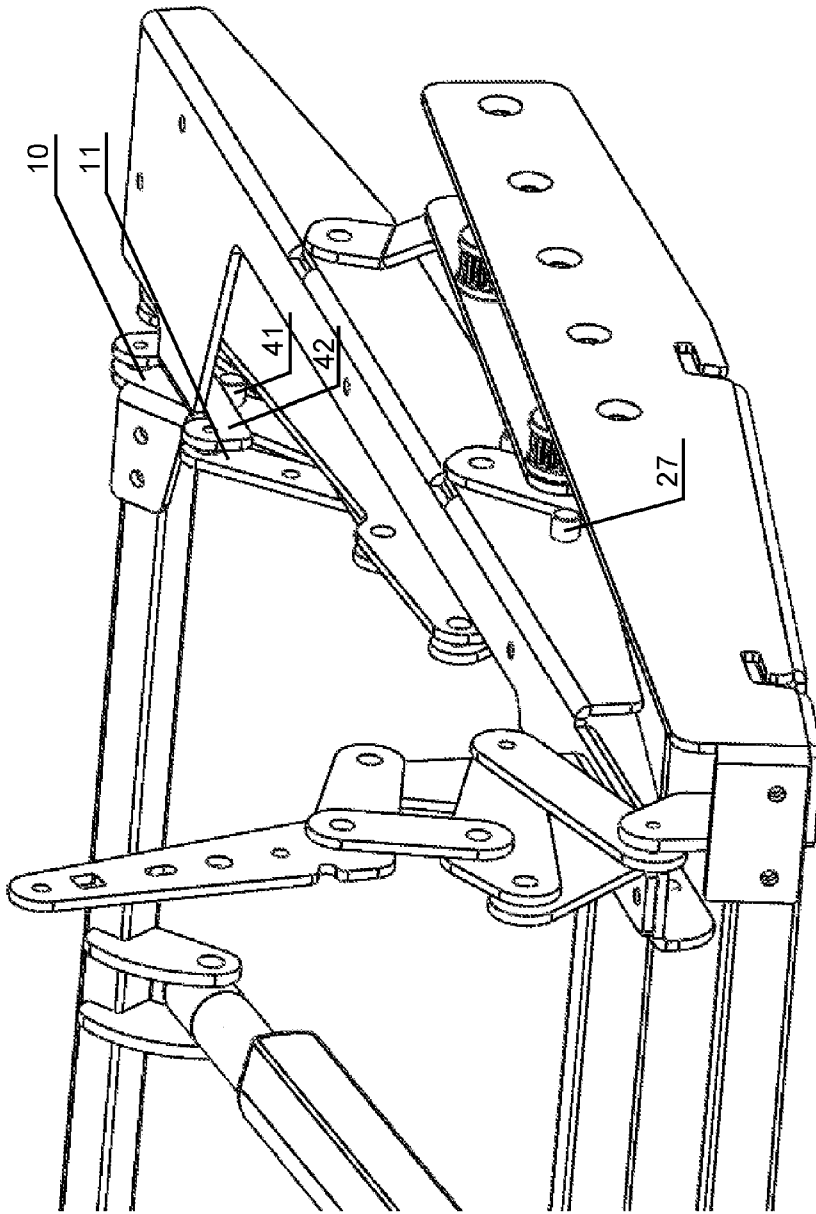

Fig. 5

Fig. 6

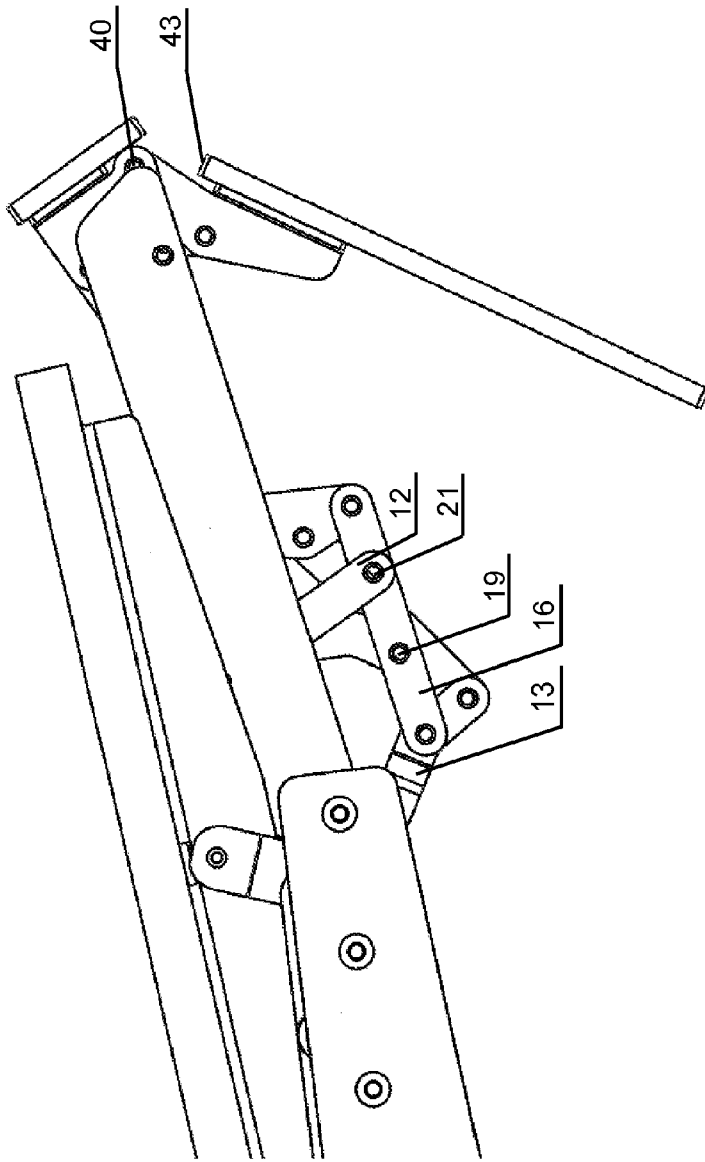

Fig. 7

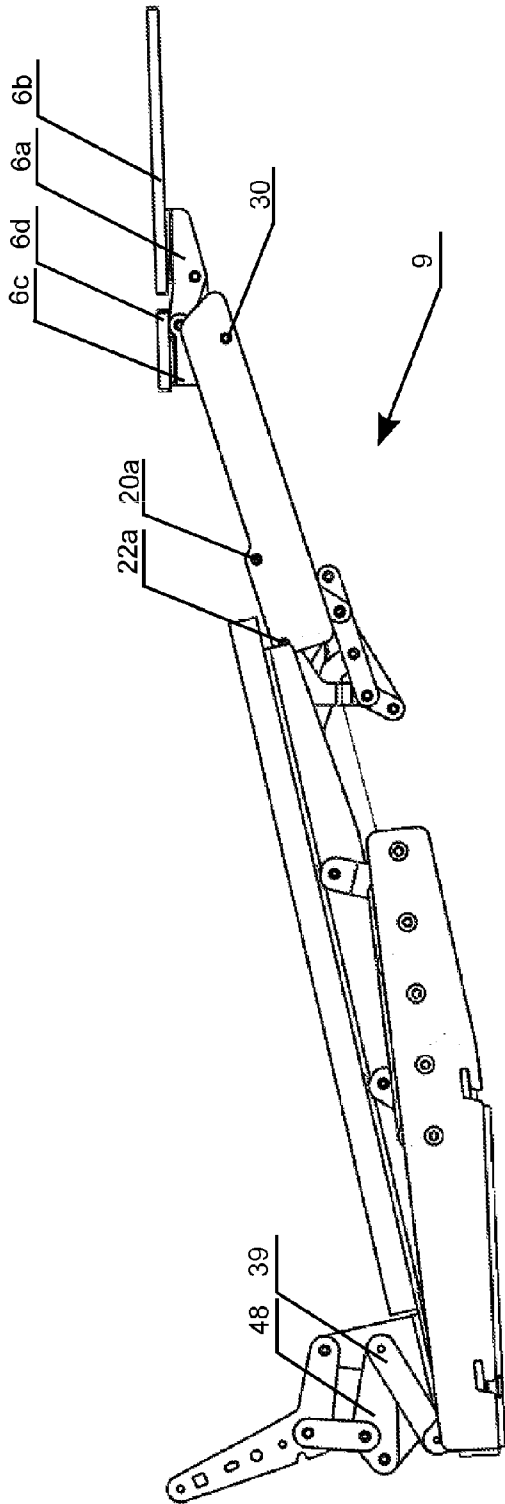

Fig. 8

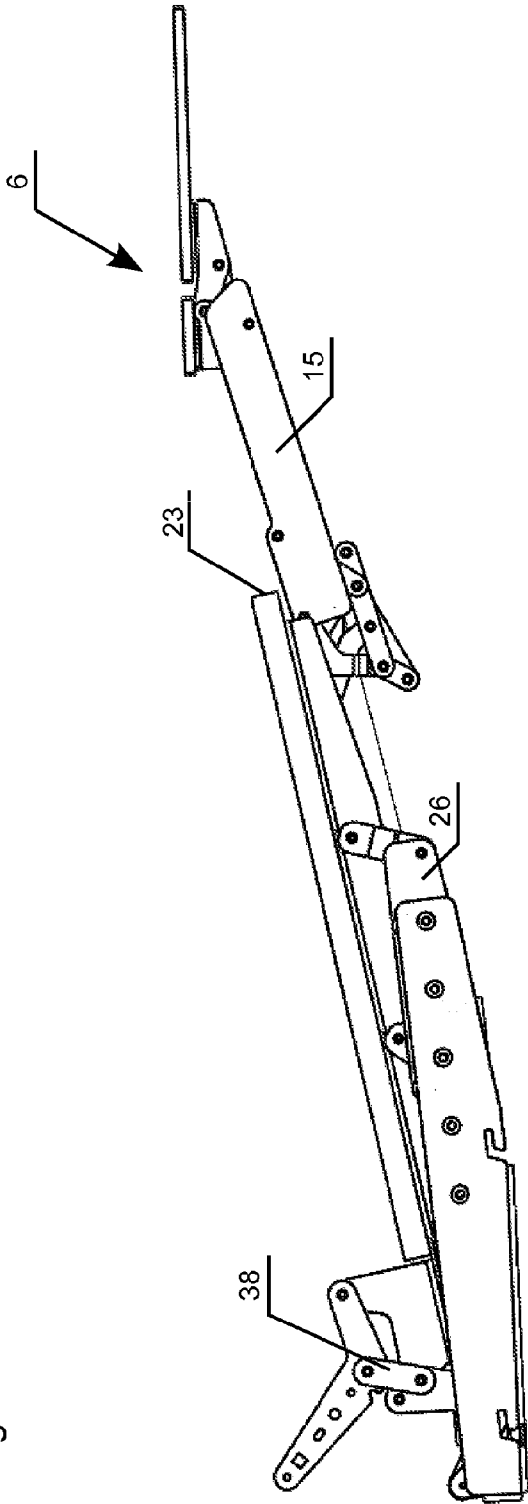

Fig. 9

