

[72] Inventor **Gernot Gottschall**
Boeblingen, Germany
 [21] Appl. No. **877,628**
 [22] Filed **Nov. 18, 1969**
 [45] Patented **June 15, 1971**
 [73] Assignee **Morat Franz GmbH**
Stuttgart-Vaihingen, Germany
 [32] Priority **Nov. 20, 1968**
 [33] **Germany**
 [31] **G 68 07 789.4**

[50] Field of Search..... 200/61.41,
 61.42; 340/267, 259

[56] **References Cited**
UNITED STATES PATENTS
 3,213,225 10/1965 Torres..... 200/61.41
 3,321,755 5/1967 Cooke..... 340/267 X

Primary Examiner—John W. Caldwell
Assistant Examiner—Michael Slobasky
Attorney—Michael S. Striker

[54] **FEELER-CONTROLLED STOP MOTION DEVICE**
9 Claims, 6 Drawing Figs.

[52] U.S. Cl..... 340/267,
 200/61.41
 [51] Int. Cl..... H01h 3/16

ABSTRACT: A thyristor circuit is assembled in a small tubular casing which is mounted on a knitting machine. A feeler projects from the casing and contacts an improperly placed latch of a needle to produce a current pulse firing the thyristor so that the same energizes the relay for stopping the motor of the knitting machine.

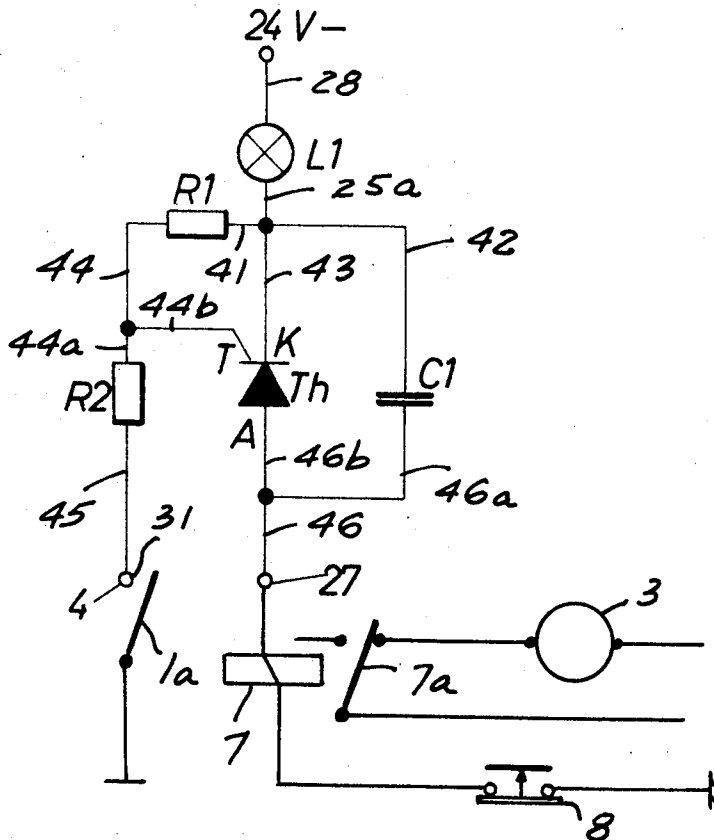

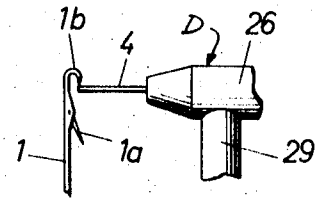
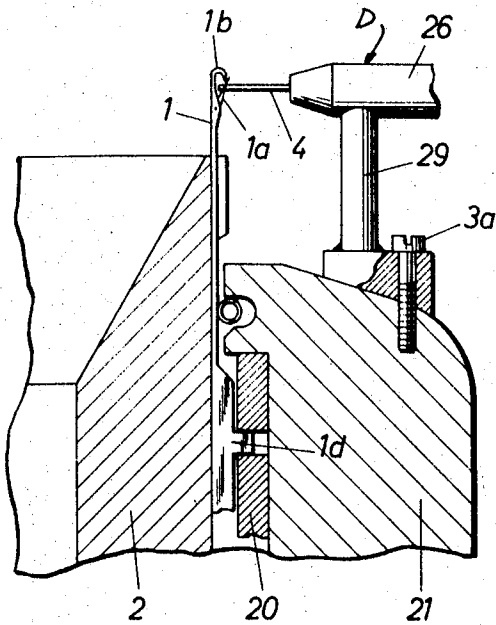

FIG. 1

FIG. 2

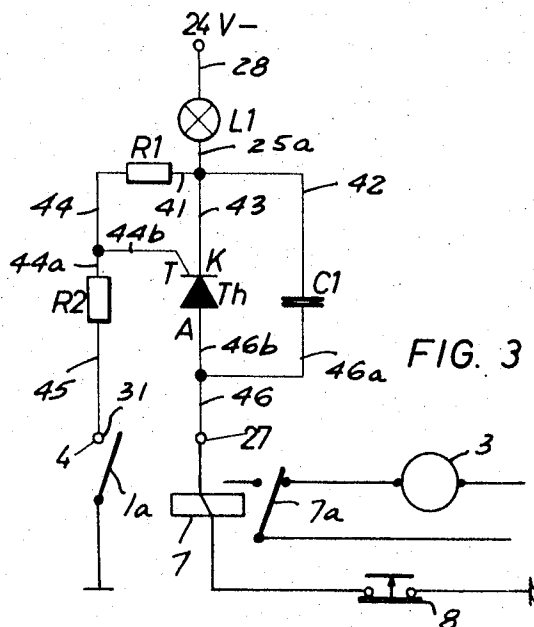
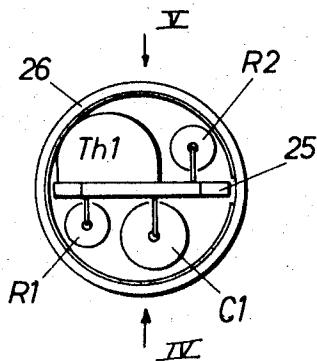
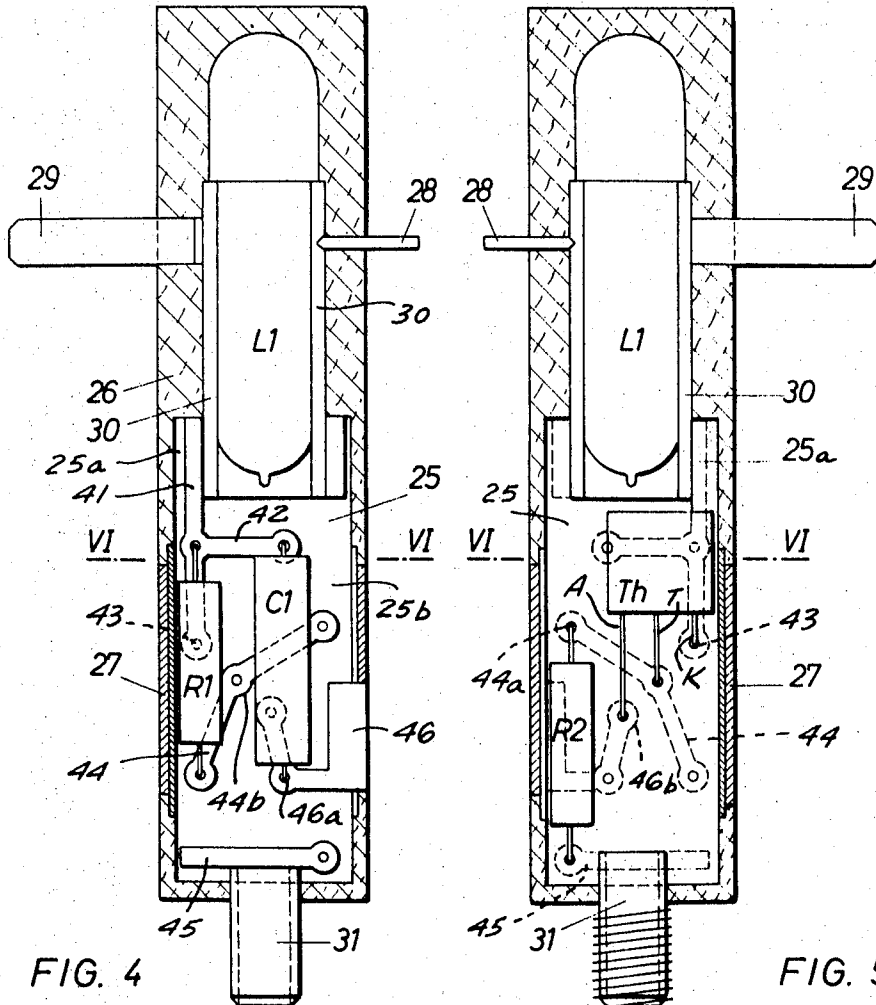

FIG. 3

INVENTOR:
GEBRÜDTER GOTTSCHE

By Michael J. Stiller
Attorney



INVENTOR:
GERNOT GOTTSCHALL
By: (Michael) Stehr
4/11/71

FEELER-CONTROLLED STOP MOTION DEVICE

BACKGROUND OF THE INVENTION

During the operation of a knitting machine, the cylinder needles move along a circular path, and the latches of the same are opened and closed. In the highest position of the needle, in which a yarn is caught, the latch has to be opened, but it occasionally occurs that the latch is partly closed which causes an irregularity and fault in the knitted fabric. It is known to sense the position of the latch during rotation of the needle cylinder, and to stop the machine by stop motion disconnecting the motor, if the sensing means senses a latch in an improper position.

Apparatus according to the prior art serving this purpose is complicated and requires manual assembly so that the cost of devices, according to the prior art, is high. Furthermore, the circuit of the device consists of many connected parts which due to the vibrations of the machine, become loose so that complete reliability of the device, according to the prior art, is not assured.

SUMMARY OF THE INVENTION

It is one object of the invention to overcome the disadvantages of the prior art stop motions, and to provide a feeler-controlled stop motion device of simple and compact construction which has a long span of life.

Related object of the invention is to fit all circuit parts of the device into a small casing from which a feeler projects.

Another object of the invention is to provide the feeler-controlled shockproof stop motion device.

Another object of the invention is to provide a feeler-controlled shockproof stop motion device with a circuit plate with attached conductors so that no manual connections have to be made.

With these objects in view, one embodiment of the invention comprises a hollow insulating casing preferably molded of an epoxy resin; a circuit plate including an insulating plate diametrically positioned in the interior of the casing at one end of the same, and conductor means secured to the insulating plate; a thyristor and resistor means mounted in the casing between the same and the circuit plate and being connected by the conductor means; a signal lamp fitted into the other end of the casing and having a first terminal adjacent the inner end of the contact plate and connected with the conductor means; a contact pin passing through a wall of the casing and having an inner end in contact with the second terminal of the signal lamp, and an outer end adapted to be connected with a voltage source; a contact ring surrounding the casing connected with said conductor means, and adapted to be engaged by a metal part of a machine supporting the casing; and a conductive feeler means secured to the end of the casing adjacent the circuit plate and being connected with the conductor means.

The conductor means which are permanently attached to the insulating plate, connect the thyristor, the resistor means, the lamp, the contact ring, and the feeler means in such a circuit that the thyristor is fired and generates a current for stopping the machine and for illuminating the lamp when the feeler means engages an improperly placed latch of a needle of the knitting machine, or other metal part.

Preferably, the contact ring is in contact with a grounded metal part of the machine, and one terminal of the voltage source is also connected to ground. The other terminal of the voltage source is connected through the signal lamp with the cathode of the thyristor.

The current flowing through the conductive thyristor also flows through a relay which operates a relay contact disconnecting the motor of the machine when an improperly placed needle latch is sensed by the feeler.

The lamp, the thyristor, two resistors, a capacitor, and the circuit plate are preferably embedded in a cylindrical casing consisting of an epoxy resin such as Araldit. A screw supporting a resilient wire feeler projects from one end of a casing,

and is in conductive connection with a conductor of the circuit plate. Due to the fact that the electrical elements of the device are embedded in a cast casing consisting of an insulating material, not only the cost of manufacturing is low, but the device is also shockproof, and the electric and electronic components are reliably insulated.

Preferably, one resistor and a capacitor are located on one side of the circuit plate, and another resistor and the thyristor are located on the other side of the circuit plate which diametrically extends through a cylindrical casing so that the available space in the interior of the same is fully used.

The novel features which are considered as characteristic for the invention are set forth in particular in the appended claims. The invention itself, however, both as to its construction and its method of operation, together with additional objects and advantages thereof, will be best understood from the following description of specific embodiments when read in connection with the accompanying drawings.

BRIEF DESCRIPTION OF THE DRAWINGS

FIG. 1 is a fragmentary side view illustrating the device of the invention sensing a needle which is in a desired condition;

FIG. 2 is a fragmentary axial sectional view illustrating a portion of the circular knitting machine provided with a device according to the invention sensing an improperly placed latch of a cylinder needle;

FIG. 3 is a diagram illustrating the electric circuit of the device;

FIG. 4 is a longitudinal sectional view of the device taken in the direction of the arrow IV in FIG. 6;

FIG. 5 is an axial sectional view of the device taken in the direction of the arrow V; and

FIG. 6 is a cross-sectional view of the device taken on line VI-VI in FIGS. 4 and 5.

DESCRIPTION OF THE PREFERRED EMBODIMENT

While the device can be used for other machines as well, FIG. 2 shows, by way of example, a circular knitting machine with a rotating needle cylinder 2 and a cam box 21 provided with cams 20 forming a cam track for the butt of a cylinder needle 1 which is guided in a peripheral axially extending channel of knitting cylinder 2 so that needle 1 is raised and lowered in accordance with the shape of the stationary cam track of cam box 21. FIGS. 1 and 2 show the needle in the highest knit position in which the latch 1a must be opened so that a new thread can be caught by the hook 1b. In FIG. 1, cylinder needle 1 is in the correct position, and a feeler 4 of the device D is passed by the needle without being deflected or engaged, since the hook 1b is open. In the position of FIG. 2, however, the latch 1a is in improper position, partly closing hook 1b which would cause fault in the knitted material. The improperly placed latch 1a, moving with cylinder needle 1 and needle cylinder 2 along a circular path, engages feeler 4, which is resilient, and displaces the same until latch 1a has passed the feeler 4 which returns resiliently to its normal position. While the improperly placed metal latch 1a is in conductive contact with the metal feeler 4, a circuit is closed, as will be explained hereinafter, which results in the stopping of the knitting machine so that the faulty needle can be replaced before causing a substantial irregularity in the knitted fabric.

While the device D is shown to cooperate with a cylinder needle, it will be understood that the device can be used for dial needles, for other types of circular knitting machines, flatbed knitting machines, needles which are operated by jacks, or any other machine employing a latch needle.

As shown in FIG. 2, the device D has a casing 26, a supporting leg 29, and a base with a bore through which a screw 3a passes for securing the device to the cam box or other stationary part of the machine. The device D must be positioned so that the feeler 4 is located in the opening of hook 1b, and displaced by a partly closed latch 1a.

Referring now to the circuit illustrated in FIG. 3, a voltage source, preferably having 24 v., is connected to a signal lamp L1, which is connected with a resistor R1, the cathode of a thyristor TH, and a capacitor C1. The other end of resistor R1 is connected with the gate T of the thyristor, and with a second resistor R2 which is connected with the feeler 4. The anode of the thyristor and the other side of capacitor C1 are connected via relay 7 and switch 8 with a contact 27 which is connected to ground.

When the feeler 4 engages a latch 1a of the grounded needle 1, resistors R1 and R2 divide the voltage so that a small pulse flows through the resistor R1 to the gate T of thyristor Th to ground at 27. The pulse is insufficient to operate the relay by which the motor 9 of the machine is disconnected, but fires thyristor Th so that a strong current flows through signal lamp L1, the cathode and anode of the thyristor, and to ground, and this current also flows through the relay 7 whose contact 7a disconnects the motor.

A manually operated switch 8 is also connected in series with the thyristor, and is normally closed. When the machine is stopped, the switch 8 is operated so that the main circuit of the thyristor is interrupted, and the thyristor remains nonconducting ready for the next operation, after the switch has been manually released and returned by a spring to the closed position.

Assuming a voltage of 24 v., and a relay which requires a voltage of 6 v., 18 v. remain for energizing the lamp L1.

Referring now to FIGS. 4 and 5 which illustrate the actual construction of a preferred embodiment of the invention, a substantially cylindrical casing 26, cast of an epoxy resin, and has closed ends. A circuit plate 25 is diametrically inserted into the lower end of casing 26, as best seen in FIG. 6, while a lamp L1 having two terminals 30 is embedded in the upper end of the casing. A contact pin 28 which is connected with the voltage source, penetrates the wall of casing 26 and is in contact with one of the terminals 30 of the lamp, as also shown in FIG. 3. The lower ends of terminals 30 abut the upper edge of the insulating plate 25b, and since terminals 30 are embedded in the resin, longitudinal movement of the circuit plate 25 and lamp L1 is not possible. Projections 25a of insulator plate 20 are laterally abutting on terminals 30 further securing the lamp L1.

Circuit plate 25 has a plurality of conductors secured to one side, as best seen in FIG. 4, and other conductors passing through holes in the insulating plate 25b to the other side.

A conductor 41 is in contact with the other terminal 30 of lamp L1, and has an arm 42 connected with capacitor C1, and an end portion connected with a conductor 43 passing through the insulating plate 25b and being connected with the cathode K of the thyristor Th which is located on the other side of the insulator plate 25b. The other end of resistor R1 is connected by a conductor 44 to a conductor 44a passing through a hole in insulator plate 25b and being connected with resistor R2. The center part of conductor 44 is connected with a conductor passing through the insulator plate and being connected with the gate T of the thyristor. The lower end of resistor R2 is connected with a conductor 45 by a conductor passing through a hole in the insulating plate 25b, and also connected to a screw 31 inserted into the lower end of casing 26. Feeler 4 has a coiled portion wound about screw 31 and ending in a free part which is adapted to sense the position of an improperly placed latch 1a, as explained with reference to FIG. 2. A conductor 46 has a portion 46b connected by a conductor passing through insulating plate 25b with the anode A of the thyristor, and is connected by a conductor 46a passing through the insulating plate 25b with the other side of capacitor C1. The main portion of conductor 46 passes through the wall of casing 26 and is connected with a contact ring 27 surrounding the casing 26 and being embedded in the same.

The above-described conductors, and elements R1, R2, C1, and Th, are all permanently secured to the insulating plate 25b and form with the same a unit which can be permanently embedded into the cast casing 26. The reference numerals ap-

plied to the conductors of circuit plate 25, are also provided in the diagram of FIG. 3.

Contact ring 27 can be connected to ground by an annular metal part of the machine in which casing 26 is secured by screws, not shown, engaging contact ring 27. A support pin 29 consisting of an insulating material, or being insulated from the conductive parts of the device, is embedded in the casing 26 and projects from the same, and may also be used for handling or supporting the device.

It will be understood that each of the elements described above, or two or more together, may also find a useful application in other types of feeler-controlled stopped motion devices differing from the types described above.

While the invention has been illustrated and described as embodied in a feeler device with a circuit plate and a signal lamp embedded into a resin casing, it is not intended to be limited to the details shown, since various modifications and structural changes may be made without departing in any way from the spirit of the present invention.

Without further analysis, the foregoing will so fully reveal the gist of the present invention that others can be applying current knowledge readily adapt it for various applications without omitting features that, from the standpoint of prior art, fairly constitute essential characteristics of the generic and specific aspects of the invention.

What is claimed as new and desired to be protected by Letters Patent is set forth in the appended claims.

I claim:

1. Feeler-controlled stop motion device comprising, in combination, a hollow substantially cylindrical insulating casing; a circuit plate including an insulating plate diametrically positioned in the interior of said casing at one end of the same, and conductor means secured to said insulating plate; a thyristor and resistor means mounted in said casing between the same and said circuit plate and being connected by said conductor means; a signal lamp fitted into the other end of said casing and having a first terminal adjacent the inner end of said circuit plate and connected with said conductor means, and a second terminal; a contact pin passing through a wall of said casing and having an inner end in contact with said second terminal, and an outer end adapted to be connected with a voltage source; a contact ring surrounding said casing connected with said conductor means, and adapted to be engaged by a metal part of a machine supporting said casing; and a conductive feeler means secured to said one end of said casing projecting from the same and being connected with said conductor means, said conductor means connecting said thyristor, said resistor means, said lamp, said contact ring, and said feeler means so that said thyristor is fired and generates a current for stopping the machine and for illuminating said lamp when said feeler means engages an improperly placed other moving metal part of the machine.

2. Feeler-controlled stop motion device as claimed in claim 1 wherein said conductor means connect the cathode and anode of said thyristor in series with said terminals of said lamp; wherein said resistor means include a first resistor and a second resistor having connected ends; wherein said conductor means connect the connected ends of said first and second resistors with the gate of said thyristor, and the other ends of said first and second resistors with said feeler means and said cathode of said thyristor, respectively.

3. Feeler-controlled stop motion device as claimed in claim 2 comprising a capacitor mounted between said casing and said circuit plate; and wherein said conductor means connect said capacitor in parallel with said thyristor.

4. Feeler-controlled stop motion device as claimed in claim 3 wherein one of said resistors and said capacitor are located on one side of said circuit plate, and the other resistor and said thyristor are located on the other side of said circuit plate; and wherein said conductor means include conductors secured to a surface of said insulating plate, and other conductors passing through said insulating plate.

5

6

5. Feeler-controlled stop motion device as claimed in claim 1 wherein said insulating casing consists of a molded epoxy resin in which said contact ring, said insulating plate, and said terminals of said lamp are embedded.

6. Feeler-controlled stop motion device as claimed in claim 1 wherein said feeler means includes a screw threaded into the end wall of said casing at said one end of the same and in contact with said conductor means, and a partly coiled conductive feeler mounted on said screw and being resiliently deflected when engaging the improperly placed moving part of the machine.

7. Feeler-controlled stop motion device as claimed in claim

1 including a supporting pin transversely projecting from said casing and having one end embedded in the same.

8. Feeler-controlled stop motion device as claimed in claim 1 in combination with a relay connected with said thyristor energized and operated by said current and including a relay contact for disconnecting the motor driving the machine when said relay is energized by said pulse.

9. Feeler-controlled stop motion device as claimed in claim 1 in combination with a source of voltage having one terminal connected with said contact pin, and the other terminal connected to ground.

15

20

25

30

35

40

45

50

55

60

65

70

75