



US00D346750S

United States Patent [19]

[11] Patent Number: **Des. 346,750**

DeVeau, Jr. et al.

[45] Date of Patent: **** May 10, 1994**

[54] **REFERENCE POWER MODULE FOR MEASURING LIGHT ENERGY ENTERING AN OPTICAL FIBER SPLICE**

for measuring light energy entering an optical fiber splice, as shown and described.

[75] Inventors: **George F. DeVeau, Jr.**, Stone Mountain; **Walter S. Konik**, Lilburn, both of Ga.

[73] Assignee: **AT&T Bell Laboratories**, Murray Hill, N.J.

[**] Term: **14 Years**

[21] Appl. No.: **954,369**

[22] Filed: **Sep. 30, 1992**

[52] U.S. Cl. **D10/46**

[58] Field of Search 361/386, 388, 392; 336/90, 92, 200; 363/15, 95; 307/150, 151; 174/52.1, 52.2; 385/134; D13/110, 123, 124, 184; D10/46

[56] **References Cited**

U.S. PATENT DOCUMENTS

D. 273,783	5/1984	Holce et al.	D13/184
3,726,296	4/1973	Friedland et al.	73/4 R X
4,319,902	3/1982	Hensel	385/134 X
5,196,899	3/1993	Serwatka	385/134 X

FOREIGN PATENT DOCUMENTS

0010306	1/1990	Japan	385/134
---------	--------	-------------	---------

Primary Examiner—Wallace R. Burke

Assistant Examiner—Joel Sincavage

Attorney, Agent, or Firm—Donald E. Hayes, Jr.

[57] **CLAIM**

The ornamental design for a reference power module

DESCRIPTION

FIG. 1 is a rear and upper left isometric view of a reference power module for measuring light energy entering an optical fiber splice showing our new design with the cover separated for the purposes of a complete disclosure;

FIG. 2 is a left end elevational view thereof with the cover shown in cross-section taken along line 2 of FIG. 3;

FIG. 3 is a rear elevational view thereof;

FIG. 4 is a top plan view of a reference power module for measuring light energy entering an optical fiber splice shown with the cover removed for convenience of illustration;

FIG. 5 is a front elevational view thereof;

FIG. 6 is a right end elevational view thereof;

FIG. 7 is a bottom plan view thereof;

FIG. 8 is a rear and upper left isometric view of a reference power module for measuring light energy entering an optical fiber splice showing our new design assembled;

FIG. 9 is a rear elevational view thereof;

FIG. 10 is a left end elevational view thereof;

FIG. 11 is a top plan view thereof;

FIG. 12 is a front elevational view thereof;

FIG. 13 is a left side elevational view thereof with the cover shown in cross-section taken along line 13 of FIG. 9; and,

FIG. 14 is a rear elevational view thereof, with the cover shown in cross-section taken along line 14 of FIG. 10.

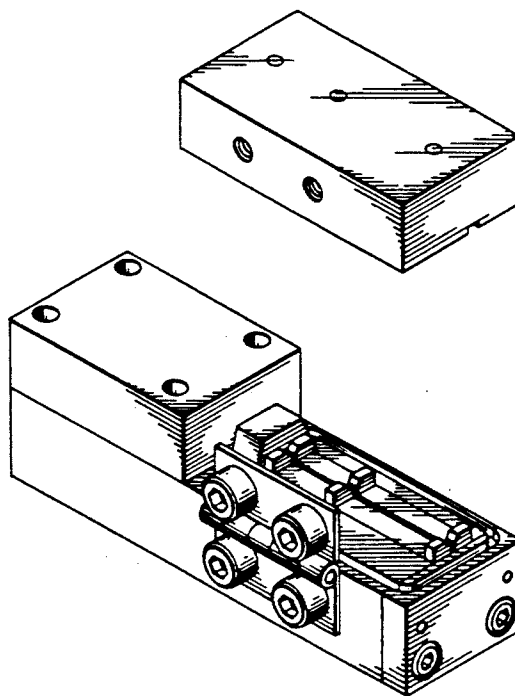

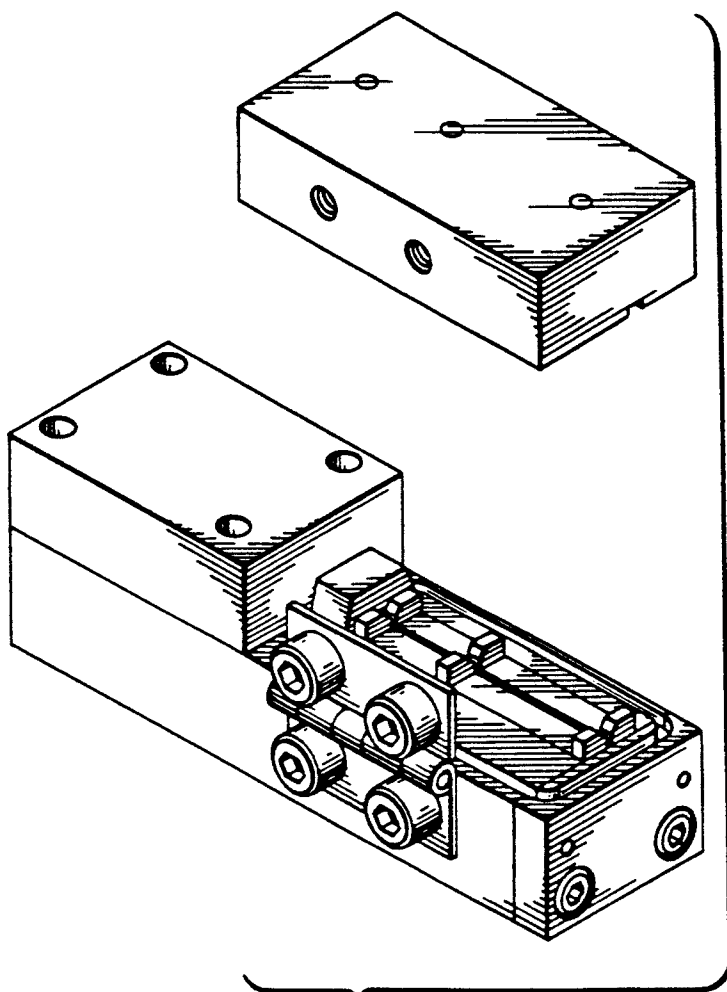

FIG 1

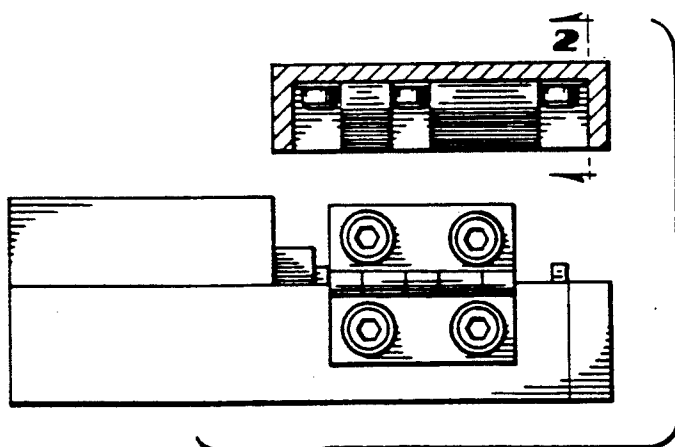

FIG 3

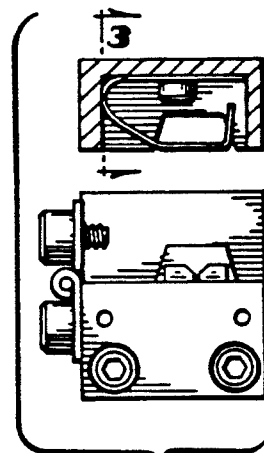

FIG 2

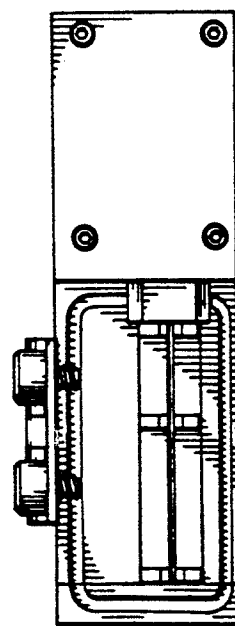

FIG 4

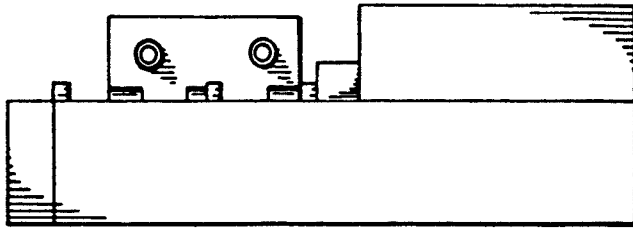

FIG 5

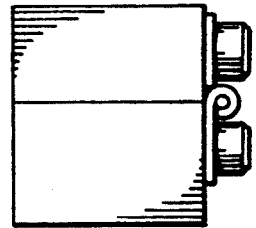

FIG 6

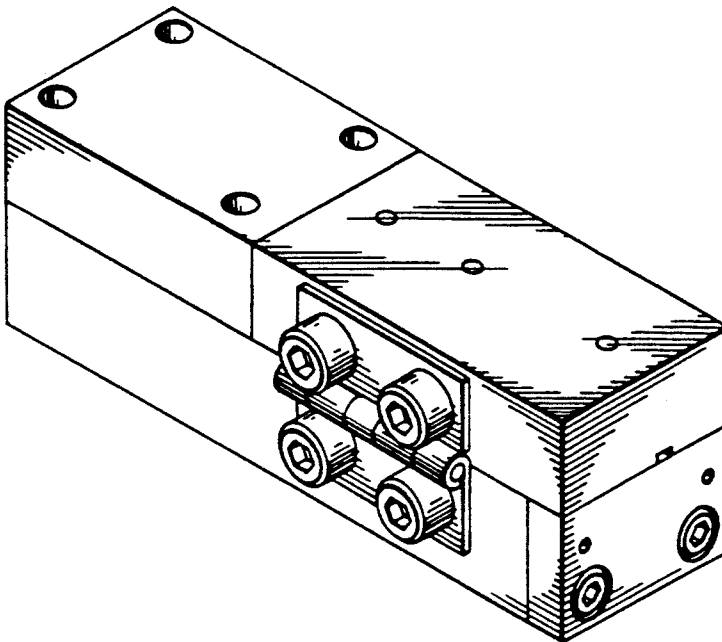

FIG 8

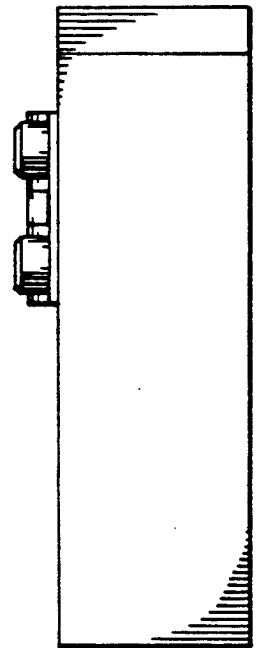

FIG 7

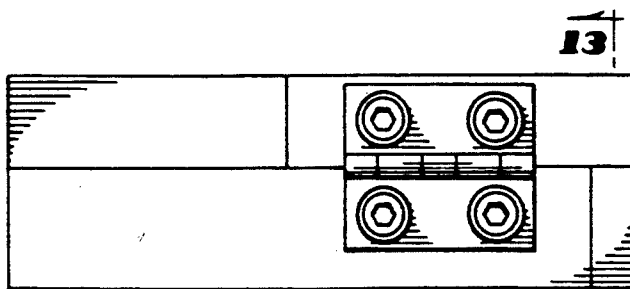

FIG 9

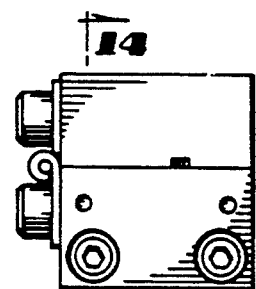

FIG 10

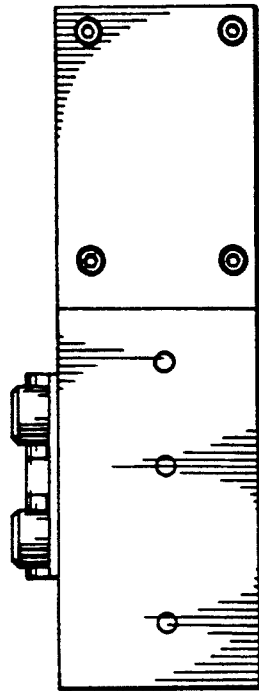

FIG 11

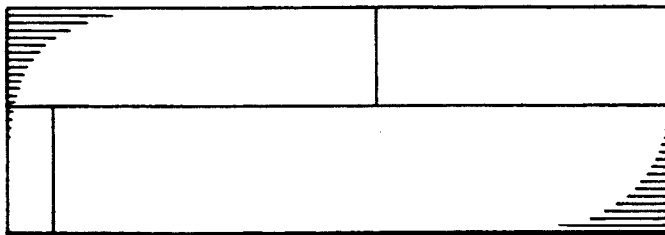

FIG 12

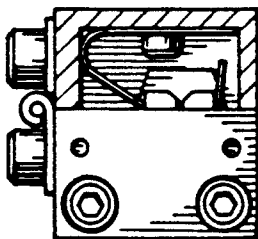

FIG 13

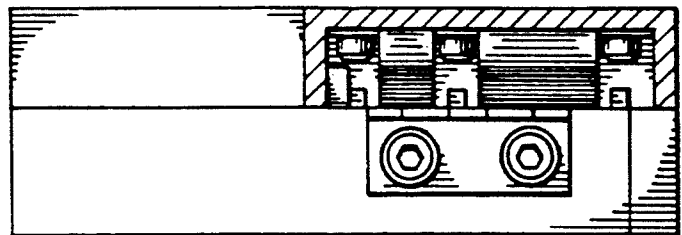

FIG 14