

Oct. 29, 1963

L. F. BLATT

3,108,794

POWER CLAMP

Filed April 26, 1962

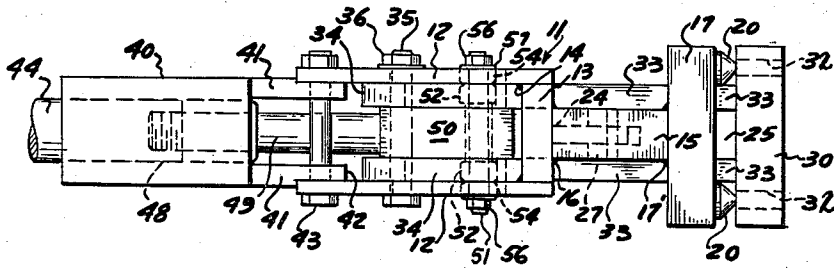

Fig. 1

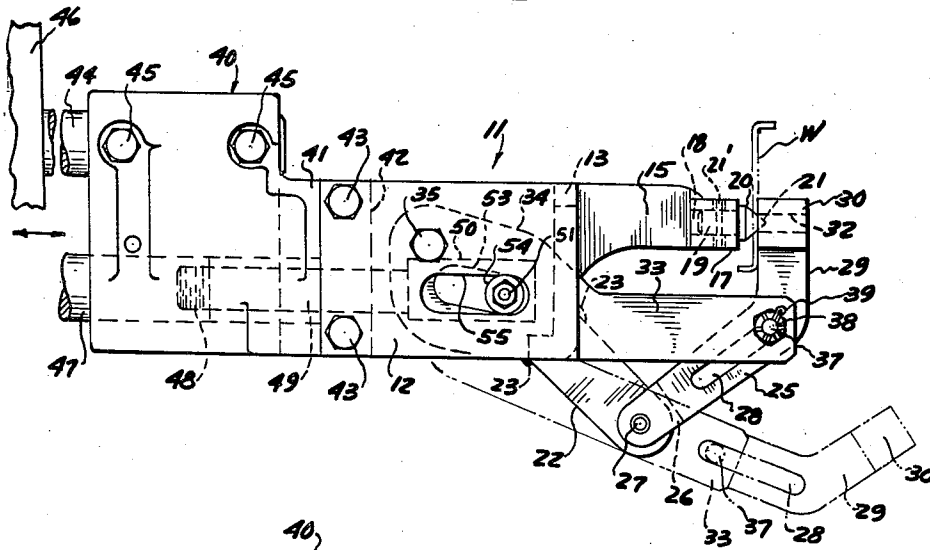

Fig. 2

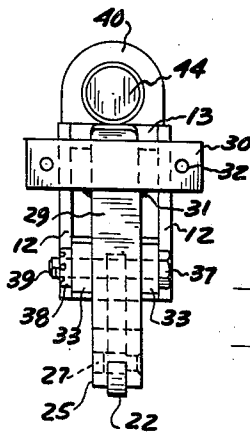

Fig. 3

INVENTOR.

LELAND F. BLATT

BY

Robert A. Aloman  
ATTORNEY

1

3,108,794

**POWER CLAMP**

Leland F. Blatt, Grosse Pointe Woods, Mich.

(24121 Mound Road, Warren, Mich.)

Filed Apr. 26, 1962, Ser. No. 190,423

7 Claims. (Cl. 269—233)

The present invention relates to a power clamp, and more particularly to a power roller automation jaw, particularly adapted for gripping vertical flanges or vertically disposed workpieces.

It is the object of the present invention to provide a power operated clamp which is particularly adaptable for gripping vertically disposed workpieces or vertical flanges thereof, and which includes a pivot arm carrying jaw, which is so disposed with respect to the fixed jaw on the body of the power clamp as to be adapted to grip a vertical flange or vertically disposed workpiece therebetween and wherein there is provided pivotally mounted clamp arm which is disposed within the jaw body, and which projects therefrom and which is connected to the pivot arm intermediate its ends and wherein reciprocal power operated means are employed for effecting power operated pivotal movements of said clamp arm for in turn effecting opening and closing movements of said pivot arm and the movable jaw carried thereby.

It is another object of the present invention to provide a differential type of motion achieved from the reciprocal rectilinear movements of a control means from which reciprocal movements are transmitted to rotary pivotal movements of the clamp arms for the purpose of in turn effecting pivotal clamping movement of the pivot arm.

It is an object of the present invention to also provide a novel mounting means on the jaw body for supporting the power operated reciprocal means limiting the same to reciprocal rectilinear movements in one plane, and including a transverse roller support carrying suitable rollers adapted to move within one or more elongated slots in a pivotally mounted clamp arm, wherein the latter slot or slots, are arranged at an acute angle with respect to the plane of reciprocal movement of the power operated means by which the reciprocal rectilinear movement of the power operated means is transmitted to a pivotal movement of the clamp arm for effecting a corresponding pivotal movement of the pivot arm carrying the jaw for retainingly engaging a workpiece.

These and other objects will be seen from the following specification and claims in conjunction with the appended drawing, in which:

FIG. 1 is a plan view of the present power operated clamp.

FIG. 2 is a fragmentary side elevational view thereof.

FIG. 3 is a right end elevational view thereof.

It will be understood that the above drawing illustrates merely a preferred embodiment of the invention, and that other embodiments are contemplated within the scope of the claims hereafter set forth.

Referring to the drawing, the present power clamp, particularly adaptable in automation operations, includes a hollow jaw body, generally indicated at 11, and which includes a pair of parallel spaced upright side walls or plates 12 transversely interconnected at their forward ends at 13, as by the welds 14. The said hollow jaw body also includes forwardly extending mounting plate 15, fixedly secured as by the welds 16 to the forward portion of the jaw body.

The transversely arranged fixed jaw 17 spans the end portion of the plate 15, and is fixedly secured thereto as by the welds 17'.

In the illustrative embodiment shown in FIGS. 1 and 2, the fixed jaw 17 includes a pair of laterally spaced

2

bores 18 adapted to snugly receive the cylindrical shanks 19 of the jaw points 20, which taper to a point as at 21 for cooperative registry with one side or through an aperture in workpiece W, which is fragmentarily shown, and which in the illustrative embodiment is in the nature of a vertical flange or is a vertically disposed workpiece, generally indicated at W.

Suitable roll pins 21' are employed for anchoring the jaw points 20 in position with respect to the fixed jaw 17.

Arranged centrally of the body 11, fixedly secured thereto as by the welds 23, shown in FIG. 2, and depending angularly downward and forward therefrom is the support 22, which thus depends below the body 11 and provides a pivot mounting 27 for the pivot arm 25 in the nature of a cantilever, whose upwardly extending portion 29 has mounted and secured thereto as at 31 by welds or otherwise the movable jaw 30, which is adapted for opposed registry with the fixed jaw 17—20, and which has formed therethrough a pair of registering apertures 32, for cooperation with the jaw points 20—21, gripping the workpiece W therebetween. Slotted end 26 of arm 25 is pivoted upon support 22.

The pivot arm 25 has an elongated slotted portion 28 formed therethrough and provides the means for the loose connection of the power operated clamp arms 33 for effecting pivotal clamping and unclamping movements of the pivotal arm 25.

In the present illustrative embodiment of the invention there are provided a pair of clamp arms 33, whose enlarged rear portions 34 extend into the body 11 upon the interior of the side walls or plates 12, and are pivotally mounted thereon by the transverse bolt 35, and retaining nut 36, best shown in FIG. 1. The forward end portions of the pivotal clamp arms 33 extend around opposite sides of pivot arm 25 and are pivotally connected thereto by the transverse pivot pin, or bolt, 37, which extends through end portions of the clamp arms 33 and through the elongated slot 28 in the pivot arm and is fixedly secured in position by the nut 38 and cotter pin 39.

The mount for the jaw body 11 is generally indicated at 40, and includes, as best shown in FIGS. 1 and 2, the forwardly extending plates 41 which project into the body 11, adjacent the inner surfaces of the body plates 12 and are fixedly secured thereto by the transverse bolts 43. The jaw hanger rod 44 projects horizontally into and through a bore within the mount 40 and is fixedly secured thereto as by the fastening bolts 45.

As fragmentarily shown in FIG. 2 the support means 46 is shown for mounting the jaw hanger rod to thus illustrate a means for supporting the said jaw hanger rod which in turn through the mount 40 movably mounts or otherwise supports the jaw body 11 for a particular clamping operation.

One method of use is disclosed in United States Patent 3,013,835, dated December 19, 1961, and directed to a power operated jaw assembly.

In accordance with the present invention, a suitable power operated means is employed such as a hydraulic or pneumatic cylinder with piston and from which extends a reciprocal piston rod, fragmentarily shown at 47, FIG. 2, and which is movably positioned into the mount 40. The said power reciprocated piston rod 47 has a threaded bore at one end, as at 48, and threadedly receives the connecting rod 49, whose opposite end portion extends between the side walls 12 of the body 11, centrally thereof, and terminates in the reciprocal block 50, hereinafter referred to as a power reciprocated actuating means.

The transverse pin or stud 51 is mounted upon and extends through the block 50 and at its opposite ends projects loosely through inclined slot 53 formed through the clamp arms 34—34 in opposed relation, as well as

through the elongated opposed slots 55, which extend through the side walls 12 of the body 11, also arranged in opposed relation. In this connection it is seen that the body slots 55 are in a plane parallel to the axis of longitudinal reciprocal movement of the block 50 and piston rod 47 and connected rod 49.

On the other hand, the said slots 53 in the clamp arms 34—34 extend at an acute angle with respect to the longitudinal axis of movement of the block 50, and at the same time are, of course, at an acute angle with respect to the longitudinal axis of the slots 55 in the said body.

In accordance with the present invention, the transverse pin 51 which extends from the reciprocal actuating means 50 carries adjacent its outer ends the rollers 54, which are movably and supportably mounted within the slots 55 in the body side walls 12, and are secured in position by the nuts 56 with suitable washers 57 interposed, and which cooperatively engage said body, but may be omitted, if desired.

The second pair of spaced rollers 52 are also mounted upon the transverse pin 51, and are movably positioned within the inclined slots 53, which extend through the clamp arms 33. By this construction it is seen that reciprocal movements of the block 50, or actuating means effects a corresponding reciprocal movement of the transverse pin 51, which is slidably and guidably mounted through its rollers 54 upon the jaw body 11. At the same time reciprocal movements of the pin mounted rollers 52 will effect pivotal movements of the respective clamp arms 33 about the pivot 35, which it is noted is displaced from the pin 51. Accordingly, from the foregoing description, it appears that reciprocal movements of the reciprocal means 50 will thus effect pivotal movements of the clamp arms 33, and such pivotal movements, acting through the pivot 37 will effect reciprocal pivot movements of the pivot arm 25, which mounts the movable jaw 30 for retaining registry and clamping with respect to the stationary jaw 17.

FIG. 2 shows in dotted lines the release position of the pivot arm 25—29, and the corresponding release position of the clamp arms 33. It is noted in this connection that the relative position of the pin 37 has changed with respect to the elongated slot 28 formed in the pivot arm 25.

The compound type of movement produced takes into consideration the fact that the pin 51 which projects from the reciprocal means 50 is vertically displaced with respect to the pivotal mounting 35 for the clamp arms 33. It is thus by this construction that the reciprocal rectilinear movement of the piston rod 47 produces through the acute angular relationship between the slots 53—55, the corresponding pivotal movements of the clamp arms 33 and the corresponding pivotal movement of the pivot arm 25—29, which carries the movable grip 30, forming a part of the present power operated clamp.

Having described my invention, reference should now be had to the following claims.

I claim:

1. A power clamp comprising a hollow jaw body; a fixed jaw projecting forwardly thereof; support means on the body, an arm pivotally mounted on said means and extending forwardly thereof and having a slotted portion; a jaw on the end of said arm movably registerable with said fixed jaw for securing a workpiece therebetween; a clamp arm pivotally mounted within the body and projecting forwardly therefrom and adjacent one end pivotally connected with the slotted portion of said arm; a

power reciprocated actuating means within said body; a transverse pin extending through said actuating means displaced from the pivotal mounting of said clamp arm and movably and guidably mounted on said body for reciprocal rectilinear movements; said clamp arm having an elongated slot extending at an acute angle to the axis of movement of said pin and movably receiving said pin; reciprocal movements of said actuating means effecting reciprocal pivotal movement of said clamp arm, and pivotal clamping and unclamping movements of said movable jaw.

2. In the power clamp of claim 1, said support means including a support at one end fixedly secured to said body and extending angularly forward and downward; said arm at one end pivotally mounted on said support.

3. In the power clamp of claim 1, said support means including a support at one end fixedly secured to said body and extending angularly forward and downward; said arm at one end pivotally mounted on said support and extending forwardly and upwardly, the jaw on said arm extending transversely of said body, said fixed jaw extending transversely of said body.

4. In the power clamp of claim 1, and a roller journaled on said pin movably and operatively positioned within said clamp arm slot.

5. In the power clamp of claim 1, said body having opposed elongated slots coplanar with the axis of movement of said means; the mounting of said pin on said body including rollers journaled on said pin and movably and guidably positioned within said body slots.

6. In the power clamp of claim 1, and a roller journaled on said pin movably and operatively positioned within said clamp arm slot, said body having opposed elongated slots coplanar with the axis of movement of said means, the mounting of said pin on said body including rollers journaled on said pin and movably and guidably positioned with said body slots.

7. A power clamp comprising a hollow jaw body; a fixed jaw projecting forwardly thereof; support means on the body, an arm pivotally mounted on said means and extending forwardly thereof and having a slotted portion, a jaw on the end of said arm movably registerable with said fixed jaw for securing a workpiece therebetween; a pair of clamp arms pivotally mounted within the body and projecting forwardly therefrom and adjacent their one ends pivotally connected with the slotted portion of said arm; a reciprocal actuating means within said body positioned between said clamp arms; said clamp arms having opposed elongated slots therethrough extending at an acute angle to the axis of movement of said reciprocal means; said body having in its opposed sides a pair of opposed elongated slots in a plane parallel to the axis of movement of said reciprocal means and at an acute angle to said clamp arm slots; a pin extending through said reciprocal means and loosely through the clamp arm and body slots; and rollers journaled and retained on said pin and respectively movably within said clamp arm and body slots; reciprocal movements of said means effecting reciprocal pivotal movements of said clamp arms and pivotal clamping and unclamping movement of said movable jaw.

References Cited in the file of this patent

UNITED STATES PATENTS

1,729,076 Laycock ----- Sept. 24, 1929  
3,027,155 Paterson ----- Mar. 27, 1962