

J. C. RYAN.
 CARDING ENGINE.
 APPLICATION FILED AUG. 11, 1914.

1,179,458.

Patented Apr. 18, 1916.

2 SHEETS—SHEET 1.

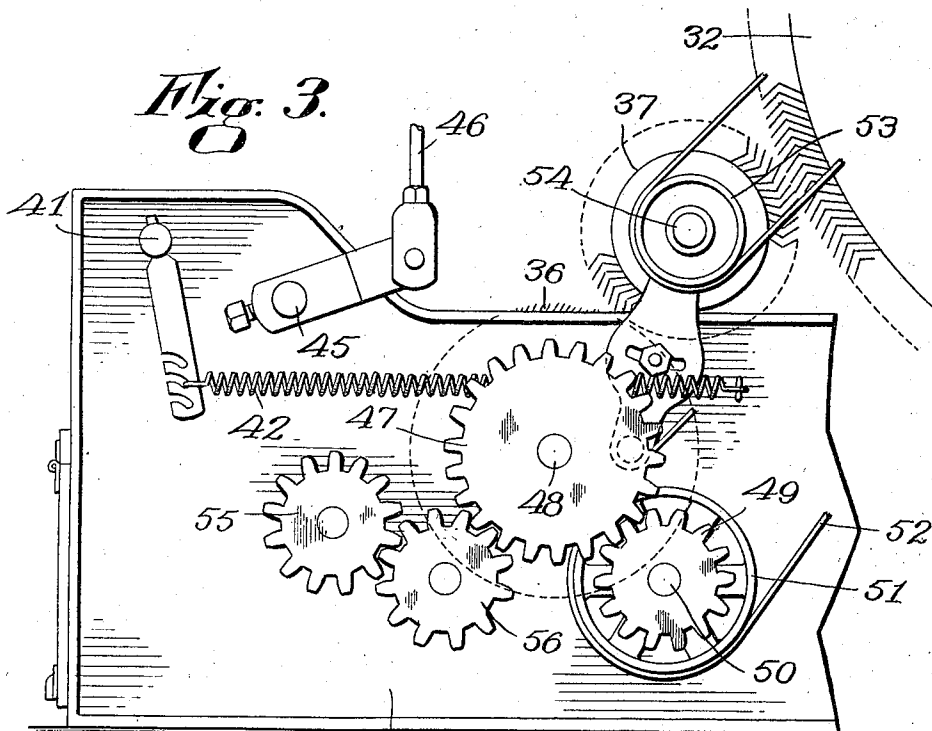
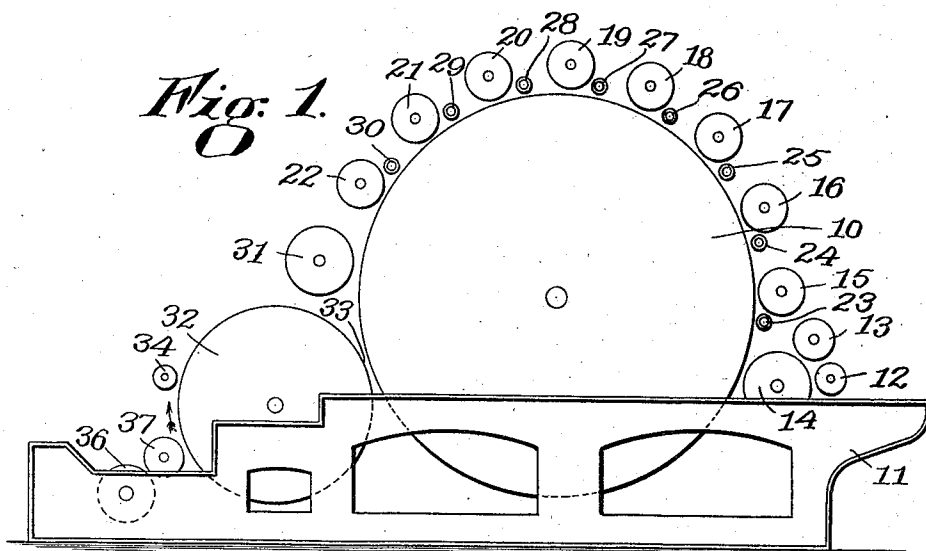

Witnesses.
 R. D. Thoman.
 H. M. Kennedy.

Inventor
 James C. Ryan
 By Attorney
 Anthony W. Bantler

J. C. RYAN.
 CARDING ENGINE.
 APPLICATION FILED AUG. 11, 1914.

1,179,458.

Patented Apr. 18, 1916.
 2 SHEETS—SHEET 2.

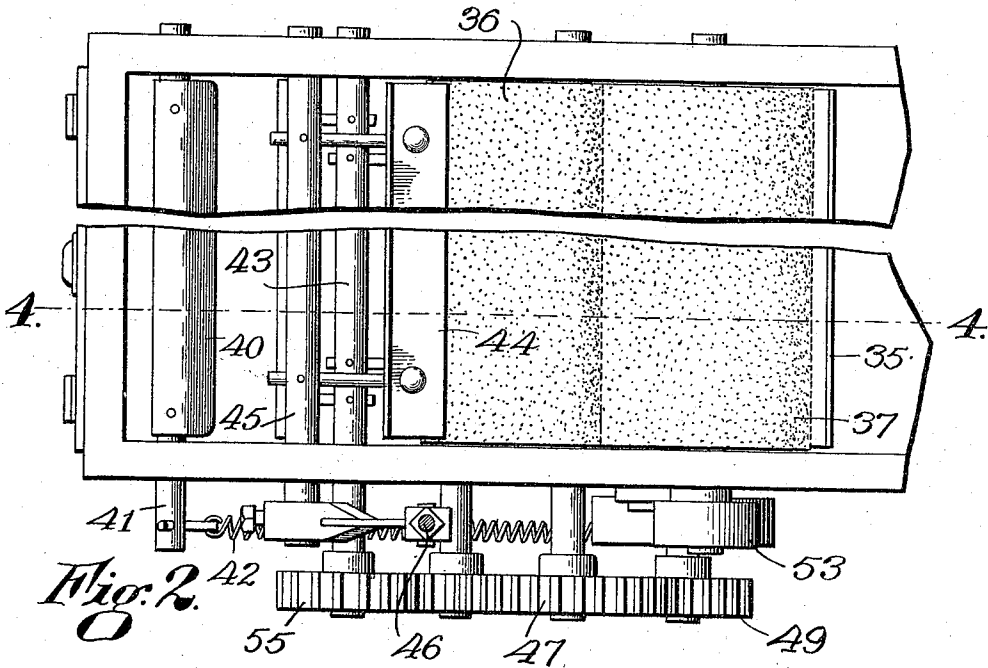

Fig. 2.
 O

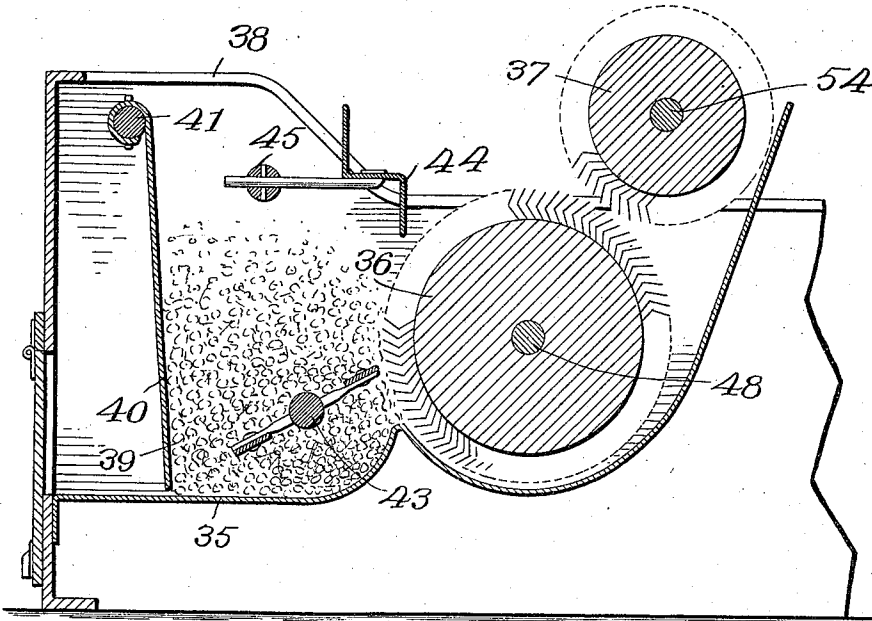

Fig. 4.
 O

Witnesses
 R. D. Tolman.
 H. W. Kennedy.

Inventor
 James C. Ryan.
 By Attorney
 Harry W. Sautter

UNITED STATES PATENT OFFICE.

JAMES C. RYAN, OF MILLBURY, MASSACHUSETTS, ASSIGNOR OF ONE-HALF TO JOHN R. GREENWOOD, OF MILLBURY, MASSACHUSETTS.

CARDING-ENGINE.

1,179,458.

Specification of Letters Patent. Patented Apr. 18, 1916.

Application filed August 11, 1914; Serial No. 856,263.

To all whom it may concern:

Be it known that I, JAMES C. RYAN, a citizen of the United States, residing at Millbury, in the county of Worcester, State of Massachusetts, have invented a certain new and useful Improvement in Carding-Engines, of which the following is a specification, reference being had therein to the accompanying drawings.

This invention relates to carding engines, but more particularly to mechanisms for feeding nubs to the stock being carded.

The yarn produced in a device of this nature is generally used to make what is commonly known as homespun cloth in which small pieces of shoddy, noils and short stapled wools of varied colors are spun in the yarn at intervals to produce a peculiar rough effect in the finished goods. Heretofore it has usually been customary to feed these nubs to the stock on the second breaker at next to the last worker, and this feeding has usually been accomplished by a box supported above such worker having its bottom open with a feeding device or churn in such opening adapted to full the nubs and deliver them to this last worker from above. In this construction the stock with the nubs therein has to pass through the worker, the fancy, and the doffer which produces considerable shrinkage. In order to overcome this disadvantage and for many other reasons which will be fully set forth, a structure has been devised by means of which the nubs may be fed to the lower side of the second breaker doffer and thus they do not have to pass through the cards of the second breaker at all. The stock after having been supplied with the nubs is removed from the doffer by the doffing comb and taken to the finisher. In this way the nubs are much more evenly distributed, there is little if any shrinkage, and the nubs themselves come out full size. With this structure you can set the card down to card the stock out clear which will give better and stronger yarn than would be possible with the card off from one-eighth to three-sixteenths of an inch, as is necessary if the nubs are to be fed at next to the last worker. When the card is thus set off, it is necessary to use clear open stock that does not require much carding, but with the mechanism of the present invention much lower grade stock can be used with better results and the finished goods look clearer.

The many other features and advantages of the invention will be fully set forth hereinafter and included in the claims.

One embodiment of the invention is shown in the drawings in which:—

Figure 1 is a diagrammatical view of a second breaker doffer with the invention embodied therein. Fig. 2, plan view of the nub feeding mechanism, as will be fully described hereinafter. Fig. 3, side elevation. Fig. 4, section on line 4—4 of Fig. 2.

Referring to Fig. 1 of the drawings which is a diagrammatical view of the second breaker, as has been stated, the main card cylinder 10 is mounted upon the base 11. The stock comes from the first breaker to the second breaker in the usual manner and is fed by the lickerin 12 to the lickerin fancy 13 and from there to the tumbler 14 which transports it to the main cylinder 10, whence it passes the various workers 15 to 22 inclusive, and their respective strippers 23 to 30 inclusive, to the fancy 31 from whence it is fed to the doffer 32 by the main cylinder 10 at 33. This doffer is rotating in the direction indicated by arrow and the stock is removed by the doffing comb 34. In operative relation with the under portion of this doffer 32 is preferably set the nub feeding mechanism shown in Figs. 2, 3 and 4 of the drawings. This mechanism here comprises a casing 35 in which is mounted the revoluble card cylinder 36 with its axis preferably substantially parallel with the axis of the doffer 32. Opposite to and in operative relation with this card cylinder 36 is the revoluble stripper cylinder 37 which is adapted to remove the nubs from the card cylinder 36 and feed them to the stock on the doffer 32. The preferred relative position of these cylinders 36 and 37 and the doffer 32 is indicated in the diagrammatical view, Fig. 1.

The casing 35 is preferably open at the top 38 to permit the nubs 39 to be fed thereto in front of the spring pressed plate 40 which forces the nubs toward the cylinder 36. This plate 40 is mounted on the revoluble shaft 41 and is controlled by the spring 42. Within the casing 35 in front of the plate 40 is a revoluble mixer or churn 43 which constantly stirs or fulls the nubs and causes them to be fed evenly to the clothing on the cylinder 36. Also within this casing is preferably mounted a comb 44 on the shaft

45 which is adapted to be oscillated by the arm 46 preferably driven by an eccentric from the main driving mechanism to the second breaker, or by any other suitable means. This comb is adapted to remove superfluous nubs from the cylinder 36 and to leave such cylinder with an even distribution of nubs thereon.

In the present invention the cylinder 36 is driven by a gear 47 on the outer end of the shaft 48 on which the cylinder 36 is mounted, and this gear 47 is driven by a gear 49 on the stud shaft 50 driven by the pulley 51 by means of belt 52 from the main driving mechanism of the second breaker or from any other convenient source of power, though it has been found advisable to have this and the stripper cylinder 37 driven by the driving mechanism which operates the second breaker in order that they may be timed relative thereto. This cylinder 37 is here driven by belt pulley 53 on the shaft 54. The mixer 43 is here driven by gear 55 in mesh with the idler gear 56 meshing with the gear 47 on the shaft 48. Suitable change speed mechanism may be provided to permit the cylinder 36 to be driven at variable speeds and thus supply a greater or less quantity of nubs to the stock on the doffer. The nubs having been removed from the cylinder 36 by the stripper 37 are then in turn removed from the latter by the doffer cylinder 32 which is rotating in the direction of the arrow in Fig. 1. The doffer is carrying at the point of engagement with the cylinder 37 its regular supply of stock and the nubs are scattered thereover upon the outer face thereof, and the stock thus treated is carried upwardly by the doffer until it reaches the doffing comb 34 from whence it is transported to the finisher in the usual manner for this type of machine.

The applicant is aware that numerous changes in the arrangement and construction of parts might readily be made by anyone skilled in the art without departing from the scope of his invention, and he does not care to be limited to the particular embodiment herein shown and described.

Claims.

1. In a device of the class described, carding mechanism including a doffer, and means for feeding supplementary stock to the regular stock after such regular stock has been fed to the doffer and before it is removed therefrom.

2. In a device of the class described, carding mechanism including a doffer, and means located substantially beneath said doffer for feeding supplementary stock directly to said doffer on its under side.

3. In a device of the class described, carding mechanism including a doffer, and a card cylinder coacting therewith to add a supplementary supply of stock to the regular stock after such regular stock is fed to the doffer and before it is removed therefrom.

4. In a device of the class described, carding mechanism including a doffer, means for feeding stock to one portion of said doffer and removing the same at another portion, and means for supplying nubs to said stock after such stock is fed to the doffer and before its removal therefrom.

5. In a device of the class described, carding mechanism including a main card cylinder, a doffer adapted to remove the stock from said main card cylinder, a comb adapted to remove the stock from said doffer, and means for feeding a predetermined quantity of supplementary material to said stock after such stock is fed to the doffer and before it is removed therefrom.

6. In a device of the class described, carding mechanism including a doffer, and means for feeding nubs to the stock upon said doffer comprising, a worker cylinder beneath said doffer and having its axis substantially parallel therewith, a comb coacting with said worker, and a stripper cylinder coacting with said worker cylinder and the under side of said doffer.

In testimony whereof I affix my signature in the presence of two witnesses.

JAMES C. RYAN.

Witnesses:

HARTLEY W. BARTLETT,
HANNAH M. KENNEDY.

Copies of this patent may be obtained for five cents each, by addressing the "Commissioner of Patents, Washington, D. C."