

(No Model.)

2 Sheets—Sheet 1.

G. W. GROVER & J. A. NORTHROP.
MACHINE FOR WETTING HAT BODIES ON CONES.

No. 526,999.

Patented Oct. 2, 1894.

Fig. 1.

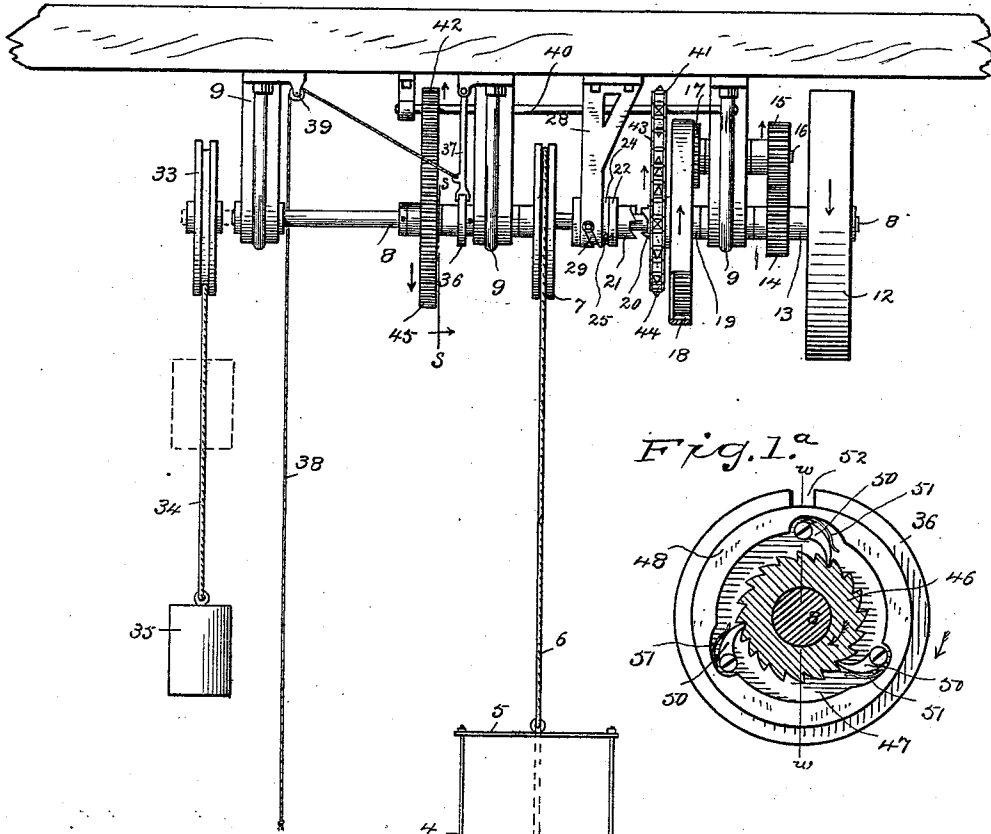

Fig. 1.^a

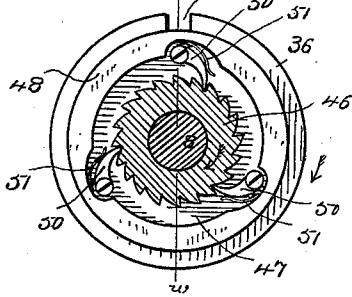

Fig. 1.^b

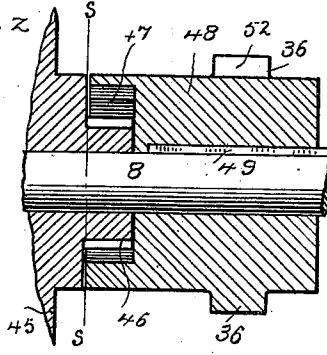
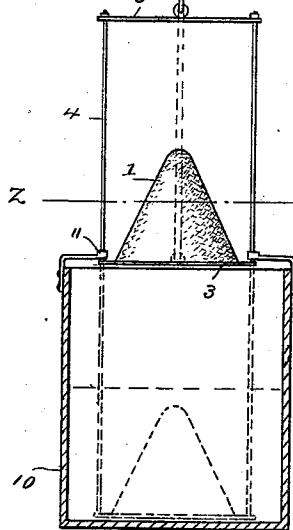
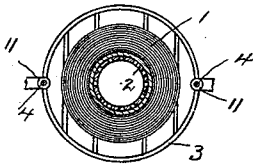

Fig. 6.



WITNESSES

H. A. Lamb
Lucie V. Richardson.

INVENTORS

George W. Grover
James A. Northrop
By J. A. Woodruff atty.

G. W. GROVER & J. A. NORTHROP.
MACHINE FOR WETTING HAT BODIES ON CONES.

No. 526,999.

Patented Oct. 2, 1894.

Fig. 2.

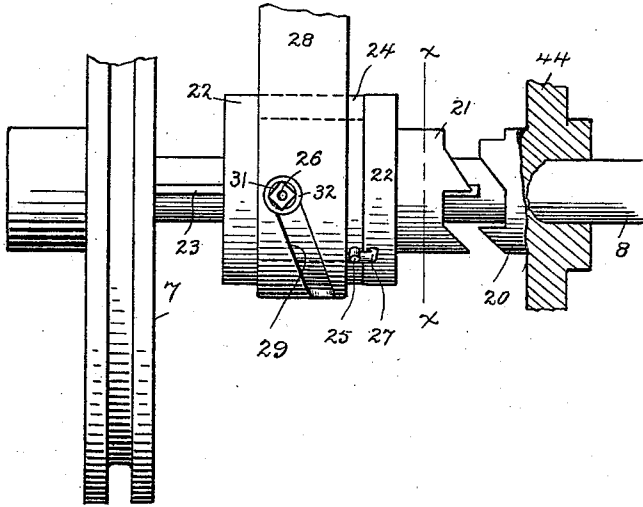

Fig. 3.

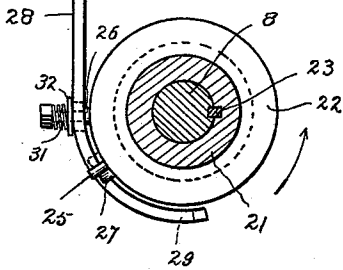

Fig. 4.

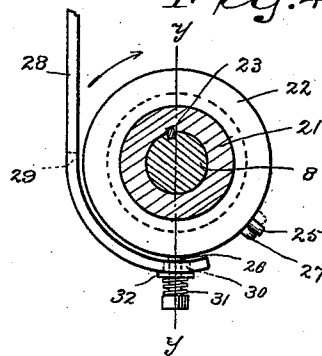
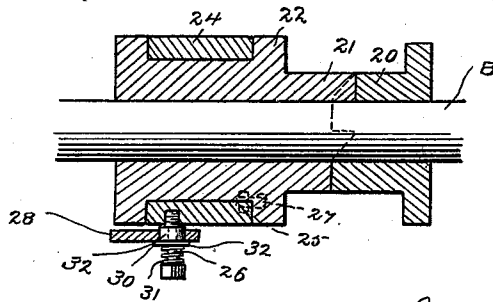

Fig. 5.



WITNESSES

H. A. Lamb
Susie V. Richardson.

INVENTORS

George W. Grover and
James A. Northrop
By A. W. Wooster, atty.

UNITED STATES PATENT OFFICE.

GEORGE W. GROVER AND JAMES A. NORTHROP, OF NEW MILFORD, CONNECTICUT; SAID GROVER ASSIGNOR TO CLARENCE L. MORGAN, OF DANBURY, CONNECTICUT.

MACHINE FOR WETTING HAT-BODIES ON CONES.

SPECIFICATION forming part of Letters Patent No. 526,999, dated October 2, 1894.

Application filed February 26, 1894. Serial No. 501,478. (No model.)

To all whom it may concern:

Be it known that we, GEORGE W. GROVER and JAMES A. NORTHROP, citizens of the United States, residing at New Milford, in the county of Litchfield and State of Connecticut, have invented certain new and useful Improvements in Machines for Wetting Hat-Bodies on Cones; and we do hereby declare the following to be a full, clear, and exact description of the invention, such as will enable others skilled in the art to which it appertains to make and use the same.

Our invention has for its object to provide a simple and inexpensive automatic machine for wetting hat bodies while on the cone.

It is well understood by those familiar with the art of hat manufacturing that after the bodies have been formed by blowing fur upon a cone the next operation is the wetting or as it is commonly called sinking of the bodies in a tank of water, which felts the fur sufficiently to permit the bodies to be removed from the cone. This operation is usually performed by hand with the assistance of more or less crude mechanical apparatus. It has not however, so far as we are aware been performed automatically. The objections to the ordinary method are the slowness with which it is necessarily performed and the consequent expense of the operation, and furthermore that unless it is performed with great care the air within the cone is forced through the top of the body so rapidly as to frequently make holes in the bodies and thereby ruin them. Our novel machine performs the entire operation of wetting the bodies automatically; the bodies being lowered at a regular and positive speed without regard to the weight of the cone and instantly raised again into position to be removed, all danger of injuring the bodies being wholly done away with. With these ends in view we have devised the novel mechanism which we will now describe referring by numbers to the accompanying drawings forming part of this specification, in which—

Figure 1 is an elevation of our novel machine complete; Fig. 1^a, a detail sectional view on an enlarged scale on the line *s s* in Figs. 1 and 1^b; Fig. 1^b, a detail sectional view on the

line *w w* in Fig. 1^a; looking toward the left; Fig. 2, an elevation on an enlarged scale of the clutch mechanism; Fig. 3, a section on the line *x x* in Fig. 2 looking toward the left, the position of the parts in Figs. 1, 2 and 3 corresponding; Fig. 4, a view similar to Fig. 3 showing the reverse position of the parts; Fig. 5, a section on the line *y y* in Fig. 4, and Fig. 6 is a section on the line *z z* in Fig. 1 looking down.

1 denotes a hat body which is represented as on a cone 2 just as it comes from the forming machine. The cone and body are placed upon a suitable open support 3 carried by rods 4 which are connected by means of a cross piece 5 to a rope 6 passing over a grooved pulley 7 fixed to a shaft 8 journaled in suitable bearings 9 depending from the ceiling or supported by any suitable framework.

10 denotes a tank partially filled with water and 11 guides secured to the top of the tank through which rods 4 pass so that the support and the cone and body thereon are held steady while being raised and lowered. Motion is imparted to the shaft by means of a belt, not shown, passing over a belt pulley 12 carried by a sleeve 13 which turns freely on the shaft.

14 is a pinion on sleeve 13 which meshes with a pinion 15 on a short shaft 16 suitably journaled in proximity to shaft 8 and carrying at its other end a pinion 17 which meshes with an internal gear wheel 18 on a sleeve 19 which turns freely on shaft 8 and is also provided with a clutch member 20. The function of pinions 14, 15, 17 and the internal gear wheel is simply that of reducing speed.

21 denotes the other clutch member which is formed integral with a sleeve 22 which is adapted to be moved longitudinally on shaft 8 but is caused to rotate therewith by means of a spline or key 23 engaging a key seat in the sleeve.

24 is a loose collar which lies in a corresponding recess in the periphery of the sleeve and is provided with an outwardly extending pin 25 and with a screw stud 26 the functions of which will presently be more fully explained.

27 is an angle pin which extends outward

from sleeve 22 and then inward at an angle and is adapted to engage pin 25 on the loose collar as will presently be fully explained.

28 is a rigid depending arm which curves partially about sleeve 22 and is provided with an oblique slot 29 through which screw stud 26 passes.

30 denotes an anti-friction roller carried by the stud which engages the slot to insure perfect freedom of movement. The roller is preferably retained in operative position by means of a spring 31 which bears against a washer 32 and against the head of the screw stud. See Figs. 4 and 5.

40 denotes a shaft journaled in proximity to shaft 8 and carrying a sprocket wheel 41 and a pinion 42. Motion is communicated to this shaft by means of a sprocket chain 43 passing over a sprocket wheel 44 on shaft 8 and over sprocket wheel 41. Pinion 42 meshes with a gear wheel 45 which is mounted on shaft 8 but is free to turn thereon and has formed integral therewith a ratchet 46 which lies within a socket 47 in a hub 48 rigidly fixed to shaft 8, as by a spline 49. Within socket 47 are pawls 50 which engage the ratchet and are held in contact therewith by springs 51.

36 is a collar on hub 48 having in its periphery a notch 52 which is adapted to be engaged by a swinging latch 37 as clearly shown in Fig. 1 to lock shaft 8, support 3, &c., at their normal position, that is, the raised position of the support.

38 denotes a cord which is connected with the swinging latch, passes over a pulley 39 and hangs down in position to be readily grasped by the operator when it is desired to release the shaft, support, &c., as in immersing a hat body on a cone, as will presently be fully explained.

As a modification of the construction just described shaft 8 may be extended at the end opposite to that which carries pulley 12, see dotted lines Fig. 1, and provided with a pulley 33 to which a rope 34 is connected said rope having attached thereto a counter weight 35. Rope 34 is wound in the opposite direction on pulley 33 from that in which rope 6 is wound on pulley 7 and the weight is suitably graduated so as to nearly but not quite overcome the weight of the support and rods carried by rope 6 with the addition thereto of a cone. When the downward movement of the cone, support, &c., takes place rope 34 is wound on pulley 33 and the counter weight is raised. The upward movement of the support, cone and hat body is produced in the same manner as before. When the support, cone and hat body are at their raised position the counter weight is at its lowest position as shown in full lines in Fig. 1. When the support, cone, &c., are at their lowest position the counter weight is at its highest position as is clearly shown in dotted lines in said figure.

The operation is as follows: It should be understood that while the machine is in use

belt pulley 12, pinions 14, 15 and 17, internal gear wheel 18, sprocket wheels 41 and 44, pinion 42, and gear wheel 45 are always in motion. Figs. 1, 2 and 3 show the parts in their normal position. Having placed a cone with a hat body thereon on support 3 as shown in Fig. 1, the operator pulls cord 38 and removes the swinging latch from the notch in collar 36 which releases shaft 8 and permits the support with the cone thereon to sink into the tank, rope 6 unwinding from pulley 7 as the cone moves downward. When the movement just described commences angle pin 27 on sleeve 22 will be in the position shown in Figs. 2 and 3, and the shaft and sleeve will be rotated in the direction indicated by the arrow in Fig. 3 the loose collar remaining stationary until an instant later as will be more fully explained. As soon as the shaft is released the natural tendency, owing to the weight of the support, cone, &c., is for the shaft to turn rapidly so that the immersion of the cone and body unless checked would take place so quickly as to force the air under the hat body through the body itself to its serious injury. Except at just the times when the support, cone, &c., are being raised or lowered collar 36 is held stationary as already described and ratchet 46 is rotating the pawls slipping over the teeth of the ratchet. The instant however, that the collar is released the shaft commences to rotate and the support, cone, &c., commence to move downward. The pawls now engage the ratchet and the collar becomes the driving power. As the natural speed of the collar, shaft, &c., owing to the weight of the support and cone is greater than the speed of gear wheel 45, the ratchet, &c., which always rotate at a uniform speed, as already explained, and can move no faster. It will be understood, however, that it will be impossible for collar 36 to rotate any faster than it can drive the ratchet, gear wheel 45 and the parts operating in connection therewith all of which parts are constantly retained at their normal rate of speed by the driving belt, not shown, which passes over pulley 12. We thus insure that without regard to the weight of the cone, the support, cone and hat body will always sink at a uniform rate of speed which is made slow enough so that it will be impossible to force the air under the hat body through the body itself. Turning now to Figs. 2 to 5 inclusive, at the time the downward movement of the support, cone, &c., commences angle pin 27 is in the position shown in full lines in Fig. 3. Starting from this position said pin travels away from pin 25 making an entire revolution and engaging pin 25 on the opposite side as indicated by dotted lines in Fig. 3. As soon as this engagement takes place pin 25 is carried forward and with it of course loose collar 24 and screw stud 26. The rotary movement of the collar on the sleeve causes the roller and the screw stud to travel in oblique slot 29 in arm 28. As the arm is rigid it of course follows

that the rotation of the collar must cause both collar and sleeve to slide on the shaft from the position shown in Fig. 2 to approximately that shown in Fig. 5, that is, to a position in which the clutch members engage. The instant this engagement takes place the downward movement of the cone and body stops and the upward movement commences instantly. It will of course be understood that the rotation of the shaft during the downward movement of the support and cone just described rotates clutch member 21 in the opposite direction from that in which clutch member 20 is constantly rotated. The instant the engagement of the clutch members takes place clutch member 21 is reversed by clutch member 20 and the shaft is rotated in the opposite direction from that in which it has been moving and rope 6 is quickly wound on pulley 7 which raises the support, cone, &c., from the immersed position, see dotted lines Fig. 1, to the position in which the parts are shown in full lines in said figure thus completing the operation and leaving the cone and hat body in position to be removed and the support in position to receive another cone and hat body. At the instant this position is reached latch 37 will pass into notch 52 in collar 36, thereby locking the parts at their normal position as shown in Fig. 1, in which position they remain until the operator again releases collar 36 by disengaging the latch from notch 52.

It will be seen that the entire operation of the machine both in immersing and raising a hat and in locking the parts in their normal position is automatic.

Having thus described our invention, we claim—

1. The combination with a support for a hat cone and a shaft from which said support is suspended, of means for locking said shaft against rotation, driving mechanism operating independently of the shaft and provided with a clutch member, a sleeve also provided with a clutch member which is carried by the shaft and is adapted to be moved longitudinally thereon, and suitable mechanism intermediate the shaft and sleeve by which the sleeve is moved to place the clutch members in engagement when the shaft is rotated by the downward movement of the support, the engagement of said clutch members causing the shaft to be reversed and the support to be raised to its normal position.

2. The combination with a support for a hat cone and a shaft carrying a pulley from which said support is suspended, of driving mechanism supported by the shaft but rotating independently thereof, a sleeve carried by the shaft and free to move longitudinally thereon, a clutch member 20 rotating with the driving mechanism, a clutch member 21 on said sleeve, clutch operating mechanism by which the sleeve is moved to place the clutch members in engagement when the shaft is rotated by the downward movement of the support, the engagement of said clutch members caus-

ing the shaft to be reversed and the support to be raised, and a latch 37 by which the shaft is locked against rotation and the support held at the raised position.

3. The combination with a support for a hat cone and a shaft from which said support is suspended, of driving mechanism operating independently of the shaft, clutch mechanism by which the driving mechanism and shaft may be connected and mechanism operated by rotation of the shaft when the support moves downward to place the clutch members in engagement whereby the shaft is reversed and the support returned to its normal position.

4. The combination with a support for a hat cone and a shaft from which said support is suspended, of driving mechanism operating independently of the shaft, a clutch member 20 rotating with the driving mechanism, a sleeve 22 carried by the shaft and having longitudinal motion thereon and provided with a clutch member 21 and an angle pin 27, a loose collar 24 carried by the sleeve but capable of independent rotation and provided with a pin 25 and a stud 26, and a rigid depending arm 28 having an oblique slot 29 which is engaged by the stud so that when the shaft is rotated by the downward movement of the support the pin on the loose collar is engaged by the angle pin on the sleeve which rotates the loose collar and through the engagement of the stud with the oblique slot moves the collar and sleeve longitudinally on the shaft and places the clutch members in engagement.

5. The combination with a support for a hat cone, a shaft 8, gear wheel 45 loose thereon and carrying a ratchet 46, and driving mechanism rotating independently of the shaft, said driving mechanism carrying a clutch member 20, of shaft 40 carrying a pinion engaging gear wheel 45, a chain and sprocket connection between shaft 40 and the driving mechanism, a hub 48 carried by the shaft and having pawls engaging the ratchet, a sliding sleeve carried by the shaft, and provided with a clutch member 21 and mechanism whereby the sleeve is moved to place the clutch members in engagement when the shaft is rotated by the downward movement of the support, during which movement the pawls engage the ratchet so that the downward movement of the support is limited by the speed of the driving mechanism, the engagement of the clutch members acting to reverse the movement of the shaft, during which movement the pawls slide over the teeth of the ratchet.

6. The combination with a support for a hat cone, shaft 8 carrying a hub 48 with a collar 36 having a notch 52 and gear wheel 45 loose on said shaft and carrying a ratchet 46, of driving mechanism rotating independently of the shaft and carrying a clutch member 20, shaft 40 carrying a pinion engaging the gear wheel, a chain and sprocket connection

between the driving mechanism and shaft 40, pawls in said hub which engage the ratchet, sleeve 22 having a clutch member 21, mechanism for moving said sleeve to place the clutch members in engagement when the shaft is rotated by the downward movement of the support, and a latch adapted to engage the notch to lock the shaft against rotation when the support is at the raised position.

7. The combination with the tank having guides 11, support 3 carried by rods 4 which slide in the guides and shaft 8 from which the support is suspended, of driving mechanism rotating independently of the shaft and carrying a clutch member 20, a sleeve 22 carrying a clutch member 21 and adapted to slide longitudinally on the shaft and mechanism for moving said sleeve to place the clutch members in engagement when the shaft is rotated by the downward movement of the support.

8. The combination with support 3, shaft 8 from which said support is suspended and driving mechanism rotating independently of the shaft and carrying a clutch member 20, of sleeve 22 carrying a clutch member 21 and adapted to slide longitudinally on the shaft, mechanism for moving said sleeve to place the clutch members in engagement when the shaft is rotated by the downward movement of the support, gear wheel 45 loose on the shaft and carrying a ratchet 46, hub 48 carried by the shaft and having pawls engaging the ratchet, and mechanism intermediate the driving mechanism and the gear wheel for driving the latter, said pawls engaging the ratchet when the shaft is rotated by the downward movement of the support so that the movement is limited by the speed of the driving mechanism, and the pawls sliding over the teeth of the ratchet when the shaft is rotated by the driving mechanism through the engagement of the clutch members.

9. In combination, shaft 8, driving mechanism rotating independently of the shaft and carrying a clutch member 20, sleeve 22 carried by the shaft and having longitudinal movement thereon said sleeve having a clutch member 21, and mechanism for moving said sleeve to place the clutch members in engagement when the shaft is rotated in one direction, the engagement of said clutch members acting to reverse the movement of the shaft.

10. In combination shaft 8, driving mechanism rotating independently of the shaft

and carrying a clutch member 20, sleeve 22 carried by the shaft and having longitudinal movement thereon, said sleeve having a clutch member 21 and an angle pin 27, loose collar 24 carried by said sleeve and having a pin 25 and a stud 26, an arm 28 having an oblique slot 29 which is engaged by said stud so that when sleeve 22 is rotated by the shaft the loose collar is rotated through the engagement of the pins, and through the engagement of the stud with the angle slot the collar and sleeve are moved longitudinally on the shaft thereby placing the clutch members in engagement and reversing the movement of the shaft.

11. In combination shaft 8 having a notched collar 36, driving mechanism rotating independently of the shaft and carrying a clutch member 20, sleeve 22 carried by the shaft and having longitudinal movement thereon, said sleeve having a clutch member 21, mechanism for moving said sleeve to place the clutch members in engagement when the shaft is rotated in one direction, the engagement of said clutch members acting to reverse the movement of the shaft, and a swinging latch adapted to engage the notched collar to lock the shaft against rotation after the reversed movement.

12. In combination shaft 8 carrying a hub 48 having pawls 50, gear wheel 45 loose on said shaft and carrying a ratchet engaged by said pawls, driving mechanism rotating independently of the shaft and carrying a clutch member 20, sleeve 22 carried by the shaft and having longitudinal movement thereon, said sleeve having a clutch member 21, mechanism for moving said sleeve to place the clutch members in engagement when the shaft is rotated in one direction, and mechanism intermediate the driving mechanism and gear wheel 45 by which the latter is driven, said pawls engaging the ratchet simultaneously with the movement of sleeve 22 so that the movement of shaft 8 in one direction is limited by the speed of the driving mechanism, said pawls sliding over the teeth of the ratchet when the movement of the shaft is reversed through the engagement of the clutch members.

In testimony whereof we affix our signatures in presence of two witnesses.

GEORGE W. GROVER.
JAMES A. NORTHROP.

Witnesses:

SIMON CREHAN,
WALTER H. HINE.