

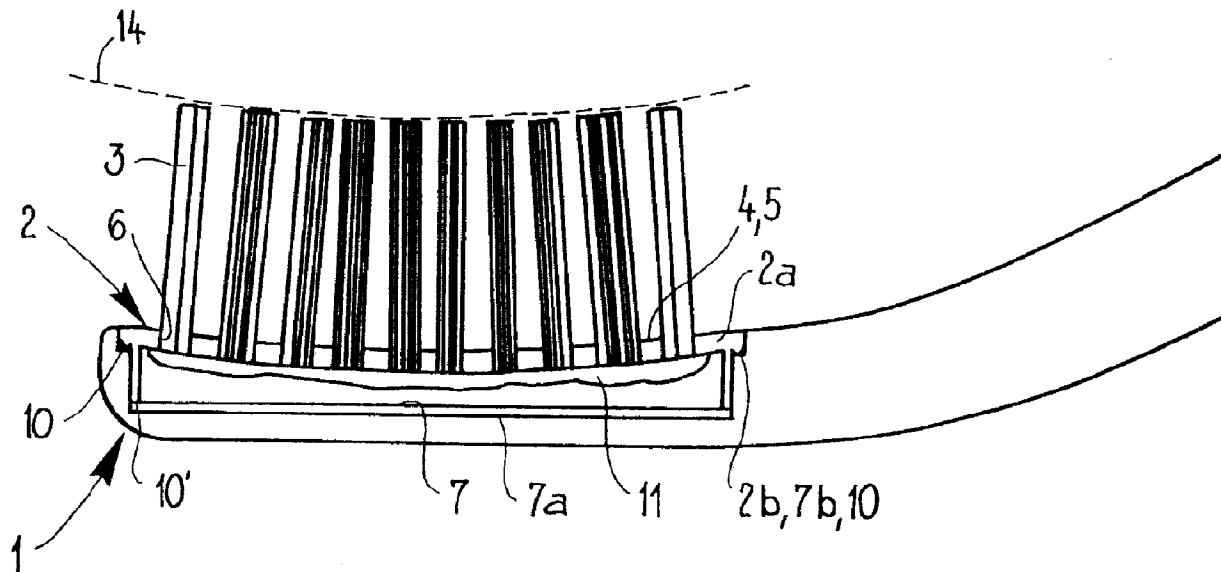

(86) Date de dépôt PCT/PCT Filing Date: 2003/09/26
 (87) Date publication PCT/PCT Publication Date: 2004/07/08
 (45) Date de délivrance/Issue Date: 2012/07/17
 (48) Date de correction/Correction Date: 2017/09/05
 (85) Entrée phase nationale/National Entry: 2005/04/26
 (86) N° demande PCT/PCT Application No.: EP 2003/010748
 (87) N° publication PCT/PCT Publication No.: 2004/056235
 (30) Priorité/Priority: 2002/12/19 (DE102 59 723.5)

(51) Cl.Int./Int.Cl. *A46D 3/04* (2006.01),
A46B 3/06 (2006.01), *A46B 9/04* (2006.01)
 (72) Inventeurs/Inventors:
PFENNIGER, PHILIPP, CH;
FISCHER, FRANZ, CH
 (73) Propriétaire/Owner:
TRISA HOLDING AG, CH
 (74) Agent: GOWLING WLG (CANADA) LLP

(54) Titre : BROSSE A DENTS ET SON PROCEDE DE PRODUCTION
 (54) Title: TOOTHBRUSH AND PROCESS FOR PRODUCING THE SAME



(57) Abrégé/Abstract:

The invention relates to a toothbrush which is produced by AFT and has a head part and at least one carrier element connected thereto, in the case of which the front surface of the head part, said front surface being formed by the top surfaces of the at least one carrier element, has a non-planar three-dimensional configuration and/or is capable of assuming such a configuration during intended use. The invention also relates to a process for producing such a toothbrush.

Abstract

The invention relates to a toothbrush which is produced by AFT and has a head part and at least one carrier element connected thereto, in the case of which the front surface of the head part, said front surface being formed by the top surfaces of the at least one carrier element, has a non-planar three-dimensional configuration and/or is capable of assuming such a configuration during intended use. The invention also relates to a process for producing such a toothbrush.

(Figure 1b)

Toothbrush and process for producing the same

The invention relates to a toothbrush and to a process which is intended for producing such a toothbrush. The invention also relates to a head part for a changeable-head toothbrush.

Producing toothbrushes by AFT (Anchor Free Tufting) technology has great advantages in relation to the conventional bristle-covering operation, in the case of which bristle filaments bent around anchors or clips are stuffed into the head part of the brush. Since the shape of the clusters of bristles is not predetermined by the size of the corresponding fastening means, more or less any desired bristle arrangements can be realized by means of AFT. In the case of AFT, use is made of a carrier plate with a plurality of cutouts through which clusters of bristle filaments are guided. The rear ends are then melted for permanent connection to the carrier plate. AFT technology is described, for example, in EP-A 0 972 464, EP-A 0 405 204 or EP-A 0 567 672. The bristle covered carrier plate is then connected to the head part of the toothbrush. Ultrasonic welding, which is described for example in DE-U 2000 6311, is preferred.

AFT technology straightforwardly allows the production of different bristle profiles, by the bristle filaments, which are guided loosely through the cutouts, being forced into the desired profile shape, using a template, before the incipient melting. However, the properties of a toothbrush or of its

- 2 -

bristle arrangement, such as rigidity, wear and cleaning efficiency, are determined not just by the material selection and the profile shape, but also the length and the setting angle of the bristles. Up
5 until now, it was not possible for these parameters, in particular the bristle length and profile shape, to be varied independently of one another in order to optimize the cleaning properties further.

WO 94/22346 discloses a toothbrush with an inflection
10 in the bristle-carrying head part, but does not describe the production process. The conventional bristle-covering operation of such a brush involves high outlay since it is only possible to compensate for height differences in the head part by compensating
15 movements of the stopping tool.

The object of the invention is thus to provide a toothbrush which, along with straightforward production, allows the largely free selection of parameters of the bristle arrangement for the purpose
20 of improving the cleaning performance. It is also intended to specify a corresponding production process.

One embodiment of the invention may include a toothbrush having a head part and at least one carrier element connected thereto, the top surface or the top surfaces
25 of the at least one carrier element defining a front surface of the head part, and the at least one carrier element having a rear surface and a plurality of cutouts through which bristle filaments are guided and, for fastening on the carrier element, are melted by way of
30 their rear ends, wherein the front surface has a non-planar three-dimensional configuration and/or is capable

- 3 -

of assuming such a configuration during intended use.

Another embodiment of the invention may include a process which is intended for producing such a toothbrush and having the steps of: guiding the bristle
5 filaments through the cutouts in the at least one carrier element and connecting them to the carrier element by melting their rear ends using a hot die; connecting the at least one carrier element to the head part preferably by means of ultrasonic welding such that
10 the front surface thereof has a non-planar three-dimensional configuration and/or is capable of assuming such a configuration during intended use.

A further embodiment of the invention may include a head part for a such a toothbrush, it being possible for the
15 head part, for the purpose of producing an exchangeable-head toothbrush, to be exchanged.

Other advantageous developments of the invention can be gathered from the description and the drawings.

The invention is based on a toothbrush produced by AFT.
20 This toothbrush has a head part and at least one carrier element which is connected thereto and has a plurality of cutouts through which bristle filaments are guided and, for fastening on the carrier element, are melted by way of their rear ends. The top surface
25 or the top surfaces of the at least one carrier element define a front surface of the finished head part. The front surface is that surface in which the roots of the bristles and of any other cleaning elements are located. According to the invention, this front surface
30 has a non-planar three-dimensional configuration and/or

- 4 -

is capable of assuming such a configuration during intended use. A suitable selection of the topography, i.e. of the non-planar shape of the front surface in the rest state and/or under loading, makes it possible
5 to produce a multiplicity of bristle arrangements. In particular, it is easily possible to vary the bristle length and the setting angle relative to the plane of the actual head part.

10 Toothbrushes with such a static and/or dynamic topography can be realized in different ways according to the invention.

A first possibility is to use a flexible carrier element which consists, for example, of a thin hard material or at least partially of a soft material, with
15 the result that dimensional and material elasticity is provided. This carrier element is preferably flat before it is installed in the head part, with the result that it can easily be covered with bristles. The hot die used for melting the bristle ends can provide a
20 hard material with the desired top-surface shape, which may additionally be fixed by the bristle melt. Alternatively, in the case of a partially flexible carrier element, the topography is only produced during insertion into the head part or during use, it also
25 being possible for a shape which is flat in the rest state to be provided.

In the case of carrier elements with a soft component, the bristles are retained, at least in a subregion, by the elastic material and are thus mounted in a flexible
30 manner. In order to achieve sufficient flexibility, it is preferable for the Shore A hardness of the elastic

- 5 -

material to be selected to be below 70, for the carrier-plate thickness to be selected to be below 4 mm and for the layer thickness of the melted material to be selected to be below 1 mm. A topography which is
5 flat or convex in the transverse and/or longitudinal direction of the head part is preferably selected, in order that a change in topography takes place during use.

Two-component carrier elements have the advantage that
10 the hard component simplifies the ultrasonic welding, and may also serve as an anchoring means for the bristles, and the soft component ensures the desired elasticity and/or deformability.

Possible hard materials are the materials used for
15 producing the head part, in particular polyethylene (PE), polypropylene (PP), PET, acrylonitrile-butadiene-styrene (ABS), styrene-acrylonitrile (SAN). An in particular thermoplastic elastomer e.g. TPE, TPU, rubber, silicone, is
20 preferably used as the soft material. In the case of a two-component configuration of the carrier element, said soft material is coordinated with the hard material, with the result that a non-releasable connection is produced.

25 A further possibility for a toothbrush according to the invention consists in using a rigid carrier element of which the top surface already has the desired topography. The rear surface may be configured to follow the profile of the top surface. Alternatively,
30 it is planar, with the result that the carrier element has different thicknesses. The first variant has

- 6 -

advantages in respect of the material consumption and the cooling times, although the AFT die has to be adapted to the shape of the rear side. In the case of the second variant, it is possible to use a
5 conventional heating die with a planar front.

A further possibility for a toothbrush according to the invention consists in using a plurality of carrier elements, which in this case may also have a planar top surface. The desired topography is predetermined by the
10 shape of the head part and/or the shape of the carrier elements, in particular by the position and alignment of the regions which are prepared for accommodating the carrier elements. According to the invention, the carrier elements are inserted at different heights
15 and/or different orientations. It is thus advantageously possible for different bristle arrangements to be realized from a plurality of elements, in the manner of a construction kit, without new carrier plates having to be produced in each case.
20 The carrier elements can be covered with bristles in parallel in the AFT machine, i.e. in one operation as a single-part bristle arrangement. In addition, zones with flexible components, e.g. flexible zones or cleaning elements, may be set up between the carrier
25 elements.

The carrier element or the carrier elements is/are preferably connected to the head part by means of ultrasonic welding. In order to ensure satisfactory welding between these parts, the welding surface is
30 preferably located in a single plane. The desired topography is thus preferably only formed within the

- 7 -

region defined by the welding surface. For example, a peripheral welding border is formed in the border region of the rear surface, this border interacting with a corresponding mating surface on the head part.

5 If this is not possible, for example because the carrier element has steps or other sudden changes in topography, it is possible to dispense with welding specifically in these regions. It is preferable, however, to utilize at least 25% of the theoretically

10 possible welding surface on the periphery of the head.

The same material is advantageously used for the carrier element, or the hard component thereof, and the head part. The two parts are advantageously assembled in a largely flush manner, i.e., within the production

15 tolerances, without edges or grooves. However, it is often not possible, in practice, to prevent a depression from forming on the boundary surface, it being possible for deposits to form in said depressions. In order for these deposits not to be

20 obvious to the user, the head part and carrier element are particularly preferably of different colors.

In a development of the invention, the material of the carrier element comprises additives, such as flavorings, temperature indicators or antibacterial

25 substances. Such additives are expensive and, rather than being used in the entire head part including the handle, by being provided on the carrier element are thus advantageously used only in the actual target region, i.e., during intended use, in the mouth.

30 Examples of the invention are described hereinbelow and illustrated in the drawings, in which:

- 8 -

figures 1a-c show a toothbrush according to the invention with a rigid curved carrier element,

5 figures 2a+b show a toothbrush with an elastic curved carrier element;

figures 3a+b show toothbrushes with a carrier element with an undulating top surface;

10 figures 4a,b show a toothbrush with a carrier element with a step;

figures 5a+b toothbrush with two elements and a shoulder located therebetween;

15 figures 6a+b show a toothbrush with a carrier element comprising three segments;

figure 7 shows a toothbrush with a carrier element with a platform-like elevation;

20 figures 8a+b show a toothbrush with a carrier element with an undulating top surface;

figures 9a+b show a toothbrush with three carrier elements;

25 figure 10 shows a toothbrush with an inflected carrier element;

- 9 -

figure 11 shows a head part
toothbrush with three
elements;

5 figures 12a+b show a toothbrush with a
carrier element with a soft
component and a hard component;

10 figures 13a-c, 14 show a toothbrush with a curved
carrier element and bristles
which can be moved relative
thereto;

figures 15a-d,16a-c show toothbrushes with a
carrier element with a hard
component in the form of a
lattice;

15 figure 17 shows a toothbrush with a
carrier element which is only
connected to it at certain
points.

All of the toothbrushes shown in the figures have a
20 handle part (not illustrated), a head part 1 and at
least one carrier element 2 which is, or can be,
connected thereto and has been covered with clusters of
bristles 3 by AFT. According to the invention, the
front surface 5 of the finished head part, said
25 surface, in the cases with just one carrier element 2
(see figures 1-4, 6-8, 10, 12-16), largely
corresponding with the top surface 4 of the latter, has
a non-planar configuration in the rest state and/or
during use. It is arched inward, i.e. in the direction

- 10 -

of the head part 1, in figure 1, arched outward in figures 2, 12-14 16, of undulating form in figures 3 and 8, planar, but compliant, in figure 15, and provided with inflections or steps in the rest of the figures. By this means, and by corresponding selection of the bristle lengths, it is possible to produce bristles profiles 14, 15 which differ in the longitudinal and transverse directions in relation to the head part 1 and have different levels of rigidity for the clusters of bristles 3.

The carrier element 2, for the purpose of accommodating the clusters of bristles 3, has a plurality of cutouts 6 running between its top side 4 and its rear surface 8. By virtue of the alignment of these holes 6, it is possible to adjust the setting angle of the clusters of bristles 3. In terms of production, however, it is preferred for the holes 6 to run in the direction of the normal of the top surface 4. For fastening on the carrier element 2, the rear ends 3a of the clusters of bristles 3 are melted by a heating die 12 (see figure 1c), with the result that a bristle coating 11 is produced. It is possible to provide further cleaning elements 19 which are made of flexible material (see figures Sa, b) and have preferably been produced during the production of the carrier element 2 by two-component injection molding, before the bristle-covering operation. Even if the carrier element 2 itself consists of soft material and hard material, two-component injection molding is preferably used in order to produce it. The carrier element 2, alongside the actual bristle-carrying surface 2a, has a preferably peripheral border part 9 projecting from the rear side

- 11 -

8 thereof. This border part serves, on the one hand, for centering purposes during insertion into correspondingly adapted cutouts 7 in the head part 1 and, on the other hand, for realizing welding surfaces 5 la, 10' for ultrasonic welding. The border 9 also serves as a lateral boundary for the bristle melt 11.

In the case of the toothbrush shown in figures 1a and b, the carrier element 2 consists of a hard material, is largely rigid and is already arched concavely, both 10 in the longitudinal direction and in the transverse direction, before it is installed in the head part 1. Its top side 4 and underside 8 run parallel to one another. The material thickness is preferably less than 5 mm, particularly preferably less than 3 mm. The 15 bristles are all the same length, with the result that a bristle profile 14, 15 which follows the profile of the top surface 4 and of the front surface 5, and is concave in the longitudinal and transverse direction, is produced.

20 As is shown in figure 1c, the clusters of bristles 3 are first of all inserted into the cutouts 6 in the carrier element. A heating die 12, of which the top side 13 is adapted to the profile of the rear side 8 of the carrier element, is used to melt the bristle ends 25 3a, with the result that the bristle coating 11 is formed. In the case of a contoured die, the bristle melt is advantageously of constant thickness throughout. Then, the carrier element 2 is connected to the head part by means of ultrasonic welding. For this 30 purpose, the surface 2a projects laterally beyond the border part. The resulting shoulder 2b comes into

- 12 -

abutment against a shoulder 7b of the cutout 7 during insertion into the head part 1, it being possible for the contact surface to serve as welding surface 10.

5 Furthermore, it is also possible for the bottom end 9a of the border part 9, together with the base 7a of the cutout 7, to serve as welding surface 10'. For this purpose, the parts 2b and/or 9a may have a tapered border 31 (see figures 1c, 15a and 16a), these serving,
10 during the welding operation, as an energy concentrator and a reservoir for material which is to be liquefied.

In the case of the example from figures 2a and b, the carrier element 2, or the bristle-carrying surface 2a thereof, consists largely of a thin hard material. It
15 is flat when not covered with bristles and is thus easy to cover with bristles. During the bristle-covering operation, it is moved by the heating die into the arched shape illustrated and inserted into the cutout
20 7, with the result that it arches outward in the transverse direction and the clusters of bristles 3 are fanned out relative to one another. This produces a longitudinally flat and transversely convex bristle profile 14 and 15, respectively. Tests show that the bristle melt 11 adapts itself to the new topography
25 without fracturing. The carrier element 2 is then connected to the head part 1. In order to avoid material incompatibilities during ultrasonic welding, the border part 9 preferably consists of the hard component.

30 As an alternative, the carrier element 2 may also consist of a flexible material or thin hard material

- 13 -

which is flexible enough in order, following the bristle covering operation, to be inserted into the head part in the flat state, under prestressing and arching action. For this purpose, the material thickness of the hard material is preferably not more than 3 mm. The deformable part of the carrier plate is subjected to prestressing by the deformation, with the result that the flexibility which is present in this region during use can also be determined to a considerable extent by the production of the brush. Figure 3a shows a longitudinal section of a toothbrush with a rigid carrier element 2, of which the top surface 4 is of undulating form and the rear surface 8 is flat. The thickness of the bristle-carrying surface 2a is preferably between not less than 3 mm and not more than 10 mm. Although all of the clusters of bristles 3 are in fact of the same basic length, their free lengths from the root 3c on the top surface 4 as far as their front end 3b differ on account of the height profile of the plate 2a, with the result that different elastic properties of the bristles are realized. The angle of the cutouts 6, and thus the setting angle of the bristles, likewise varies. By means of such a carrier element, it is thus easy to produce bristle plates with different free bristle lengths and profile shapes, it being possible to use a conventional flat AFT heating die.

Figure 3b shows a cross section of modification of the example from figure 3a, in the case of which the profile of the underside 8 has been adapted to that of the top side 4. The advantages are material-related savings and shorter cycles during the production of the

- 14 -

carrier elements 2 on account of quicker cooling. However, it is necessary to use a heating die which is adapted to the underside 8.

5 The toothbrush shown in figures 4a and b has a carrier element 2 of which the bristle-carrying surface 2a has a step 17 on the top side 4 and underside 8. The bristle profile 14 in the longitudinal direction follows the profile of the top surface 4 or front surface 5. Possible welding surfaces, once again, are
10 the surface 10, already described in conjunction with figure 1, beneath the surface 2a and the surface 1a' on the base of the cutout 7. The latter is preferred since, on account of the planar base 7a, it is possible to form a continuous welding surface 10'. In the case
15 of the welding surface 10, there is a non-welded location at the topography step 17. The profile of the bristle ends and the front surface 5 in the transverse direction is arched outward (figure 4b) and corresponds, in section, to figure 2b.

20 Figures 5a and b show a toothbrush with two carrier elements 2 which are arranged in two cutouts 7 to the sides of an elevated region 18 in the center of the head part 1. This produces a front surface 5 with two different levels. The carrier elements 2 are fastened,
25 as has been described above, by ultrasonic welding along the welding surface 10 on the border of the carrier elements 2, said welding surface being located outside the bristle arrangement, as seen in plan view (figure 5b) It is also possible to weld just the
30 surfaces on the periphery of the head part 1, while the surfaces 10" adjacent to the elevated region 18 remain

- 15 -

unwelded. A sufficient hold is achieved by welding at least 25% of the possible contact surfaces. The non-welded surfaces 10" can provide the brush here with flexibility, in particular if the elevated region 5 18 consists of an elastic material, with the result that the brush head yields in a partially resilient 25 manner during use.

Flexible cleaning elements 19 are arranged on the elevated region 18. Further in particular also flexible 10 cleaning elements 20 are located outside the elevated region 18. The head part 1 has been produced with these elements, and the possibly provided elastic zone, by two-component injection molding. The elevated region 18 may also be realized by a further carrier plate which, 15 as in the example of figures 9a and b, is fitted precisely, with the two other carrier elements 2, into a common cutout 7.

Figures 6a and b show a similar toothbrush, although in this case the central elevated region 18 is realized by 20 a single carrier element 2 with a stepped height profile. This is narrower in the central region 18, and the shape of the cutout 7 is adapted thereto. Welding takes place beneath the border 2b of the carrier element 2 and in the border regions of the elevated 25 region 18, with the result that the welding surface 10 runs on two levels. No welding takes place at the step locations 17. As an alternative, welding takes place on the base 7a of the cutout 7, along the surface 10'.

Figures 7a and b show a further toothbrush with a 30 centrally elevated region 18. The carrier element 2 has a central hole, with the result that it can be fitted

- 16 -

over the elevated region 18. The carrier element 2 is welded to the head part 1 along the hole and on its outer border, as a result of which additional stiffening is achieved. Clusters of bristles 3 and flexible elements 20 are located on the carrier element 2.

The carrier element 2 of the toothbrush shown in figures 8a and b is of undulating form in the longitudinal and transverse directions, this resulting in a correspondingly structured front surface 5. The bristle-carrying surface 2a is also curved at the border, with the result that the contact and welding surface 10 is likewise curved. As an alternative, welding may take place in a single plane on the base 7a (welding surface 10').

Figures 9a and b show a toothbrush with two different levels, realized by three separate carrier elements 2 with border parts 9 of different lengths L, L'. These are inserted into three cutouts 7 separated by webs 30 or into a common cutout (not illustrated) and welded on the base 7a thereof (welding surface 10'). As an alternative, welding may also take place on two levels on the surface 10, beneath the respective bristle-carrying surfaces 2a. The central carrier element 2 comprises both conventional bristles and a flexible cleaning element 19.

Figure 10 shows a toothbrush with an inflected carrier plate 2. The shape of the head part 1 and/or of the cutout 7, as is also the case in the rest of the examples, is selected such that the border of the bristle-carrying surface 2a terminates flush with the

- 17 -

head part, i.e. the top side 1a of the head part 1 here likewise has an inflected profile. Two anchoring regions with border parts 9 are provided here, as are, correspondingly, also two cutouts 7 adapted thereto. As
5 an alternative, the inflected front surface 5 may also be realized by two separate carrier plates which are adjacent to one another at the inflection 29, it additionally being possible to provide the head part 1 with a zone which is flexible in the region of the
10 inflection 29.

Figure 11 shows a head part 1 for a toothbrush with three carrier elements 2. Three cutouts 7 are provided for accommodating the latter, transverse webs 30, in particular made of flexible material, being arranged
15 between the individual cutouts. Welding takes place only on the periphery of the head part 1, along the line 10. The front surface may be designed, for example, as in figure 9.

Figures 12a and b show a toothbrush with a carrier
20 element with a soft component and a hard component. The actual bristle-carrying part 2a of the carrier element 2 is formed from a soft material 21, which is elastically deformable. The bristles are thus suspended and/or anchored in an elastic manner. The cushion-like
25 part 21 yields under loading, which is particularly advantageous for the teeth. For easier connection to the head part 1, the carrier element 2 has a peripheral frame part 22 made of preferably the same hard material as the head part. The arching is produced during the
30 production of the carrier element 2. The underside of the frame part 22 rests on corresponding shoulders 7b

- 18 -

in the recess 7 in the head part 1, the contact surface defining the welding surface 10. The cavity between the underside 8 of the carrier element 2 and the base 7a of the cutout 7 allows, during use, a certain deflection
5 of the elastic part 21, and in some circumstances even a reversal from the convex state to the concave state.

Figures 13a-c and 14 show a carrier element and the head part of the toothbrush in the case of which the rear ends 3a of the clusters of bristles 3, rather than
10 being firmly fused to the bristle-carrying surface 2a, can be displaced in the holes 6. This is achieved by suitable material selection, e.g. polypropylene for the carrier element and polyamide for the bristle filaments. Furthermore, rather than being melted to
15 form a uniform bristle coating, the rear ends 3a are melted, by a heating die 12 having protrusions 23, to form separate webs 24 made of bristle melt. For the resilient mounting of the clusters of bristles 3, an elastic membrane 25 is arranged in the head part. In
20 the case of figure 13c, this membrane is arranged within a cutout 7 and is placed in position before the carrier element 2 is fitted. In the case of figure 14, it forms an outer surface of the head part. It is molded on during the production of the head part. The
25 rear bristle ends 3a, which are melted in a die-like manner, are forced upward by the membrane, with the result that the bristle-carrying surface 2a arches to form a cushion.

Figures 15a-d and 16a-c show toothbrushes with a
30 two-component carrier element 2. The latter comprises a hard component in the form of a lattice, in this case

- 19 -

formed from sleeves 26, with holes 6 for accommodating clusters of bristles, and webs 27 which connect said sleeves. Also provided is a frame part 22 which is made of the hard component and of which the edge 31, which
5 in the application case is directed toward the base, is of tapered configuration and serves as welding surface 10. The region between the sleeves 26 is filled with an elastic soft material 28. In the example from figure 15, the material 28 is injected above and
10 beneath the webs. This produces a flat elastic structure, i.e. a toothbrush with a flat front surface 5 which deforms during use. In the example from figure 16, the material 28 is only injected above the web. The shape of the top surface 4 is influenced by
15 the shape of the injection mold. In the case of figure 16, this is selected so as to produce a cushion which yields during use. Figure 15d shows the view of a head part 1 with the carrier element 2 inserted, the webs 27, which connect the sleeves 26 and are covered
20 by soft material 28, only being depicted for explanatory purposes.

Figures 17a and b show the side view, in the longitudinal and transverse directions, of a further toothbrush, in the case of which the carrier plate 2 is
25 only welded to the head part 1 in four subregions 10. This four-point suspension renders the carrier plate particularly compliant. For this purpose, the head part has lateral cutouts 33 through which a cavity 32 beneath the carrier plate is accessible. The carrier
30 plate is spaced apart from the head part there to a considerable extent, i.e. by more than 0.5 mm. Deposits between the brush head and carrier plate may thus be

- 20 -

washed out to good effect. The carrier plate consists predominantly of elastomeric material or of a thin layer, e.g. less than 1 mm, of a hard component and can be deflected in a flexible manner in relation to the welding surfaces 10. The carrier plate is preferably provided with a lateral border of 2 mm or more (not shown here) in order that the unsightly bristle melt is not visible to the user.

All of the variants described above may also be realized as exchangeable heads, without the carrier being permanently welded to the toothbrush. It is also possible for the flexible carrier plate to perform a sensor function, e.g. for monitoring the contact pressure.

What is claimed is:

1. A toothbrush comprising:

5 a head part having a front face and a rear face;

at least one carrier element made of a hard plastic material and of a soft plastic material and connected to the head part, the at least one carrier element having a top surface, a rear surface and a plurality of cutouts running between the top surface and the rear surface of the carrier element; and

10

clusters of bristle filaments guided through the cutouts; the bristle filaments having rear ends melted to form a bristle coating, the bristle coating covering the rear surface of the at least one carrier element at least partially;

15

wherein the at least one carrier element holding the clusters of the bristle filaments is connected to the head part such that the rear surface of the at least one carrier element is at a distance from the front face of the head part thereby forming a cavity between the at least one carrier element and the front face of the head part; and

20

the at least one carrier element is at least in part resiliently deformable with respect to the head part in order to assume a non-planar three-dimensional configuration at least during use.

25

- 22 -

2. The toothbrush as claimed in claim 1, wherein the carrier element is flexible and the three-dimensional configuration of the front surface is produced in that the coating, which is formed from the melted ends of the bristle filaments and at least partially covers the rear surface, is made to solidify in a predetermined shape.
5
3. The toothbrush as claimed in claim 1, wherein the carrier element is flexible and the three-dimensional configuration of the front surface is produced in that the carrier element covered with bristles is inserted, under prestressing, into a cutout in the head part such that it arches.
10
4. The toothbrush as claimed in claim 1, wherein the hard plastic material of the carrier element has a predetermined thickness which allows deformation of the carrier element.
15
5. The toothbrush as claimed in claim 4, wherein the hard plastic material of the carrier element is of polypropylene with a thickness of not more than 3 mm.
20
6. The toothbrush as claimed in claim 1, wherein a periphery of the carrier element consists at least partially of the hard plastic material.
- 25 7. The toothbrush as claimed in any one of claims 1 to 6, wherein the carrier element has a plurality of sleeves which are connected to one another by webs and are intended for accommodating the clusters of bristles, the sleeves and webs consisting of the hard plastic material, and at least interspaces
30

- 23 -

between the sleeves and webs being filled with the soft plastic material.

8. The toothbrush as claimed in any one of claims 1 to 7, wherein at least two carrier elements are provided, these being connected to the head part at different positions such that the common front surface formed by the bristle carrying top surfaces of the carrier elements has a non-planar configuration.
9. The toothbrush as claimed in claim 1, wherein arranged on the rear surface of the carrier element is a welding border which consists of the hard plastic material and along which the carrier element is welded to the head part.
10. The toothbrush as claimed in claim 9, wherein the welding border is located in a single plane.
11. The toothbrush as claimed in claim 1, wherein the head part is exchangeable.
12. The toothbrush as claimed in claim 1, wherein the at least one carrier element comprises flexible cleaning elements made of the soft plastic material.
13. The toothbrush as claimed in claim 1, wherein the cutouts are located at least partially in the soft plastic material of the at least one carrier element.
14. The toothbrush as claimed in claim 1, wherein the cutouts are located at least partially in the hard plastic material of the at least one carrier element.

15. The toothbrush as claimed in claim 1, wherein the at least one carrier element comprises sleeves made of the hard plastic material, the sleeves including the cutouts, wherein the clusters of bristle filaments are guided through the cutouts, and the rear ends of the bristle filaments are melted to the sleeves.
16. The toothbrush as claimed in claim 15, wherein the sleeves are at least partially surrounded by the soft plastic material.
17. The toothbrush as claimed in claim 1, wherein the at least one carrier element is connected to the head part only in subsections of a circumferential region of the at least one carrier element.
18. The toothbrush as claimed in claim 17, wherein the head part has lateral cutouts through which the cavity beneath the at least one carrier element is accessible.
19. The toothbrush as claimed in claim 18, wherein the at least one carrier element is spaced apart from the head part by more than 0.5 mm.
20. A process for producing a toothbrush, comprising:
- producing at least one carrier element having a top surface, a rear surface and a plurality of cutouts running between the top surface and the rear surface, the top surface and the rear surface each having a non-planar three-dimensional configuration;
 - guiding clusters of bristle filaments through the cutouts in the at least one carrier element;

- 25 -

connecting the clusters of bristle filaments to the rear surface of the at least one carrier element by melting rear ends of the bristle filaments using a heating die, with the result that a bristle coating at least partially covering the rear surface is formed on the rear surface of the at least one carrier element; and

connecting the at least one carrier element holding the clusters of the bristle filaments and the bristle coating to a head part of the toothbrush such that the top surface of the at least one carrier element defines a front surface of the head part,

wherein the at least one carrier element is produced by two-component injection molding from a hard material and a soft material, then provided with the clusters of bristle filaments and connected to the head part.

21. The process as claimed in claim 20, wherein a flexible flat carrier element is provided and covered with bristles, the non-planar three-dimensional configuration of the carrier element being produced by the heating die as the rear bristle ends are melted.

22. The process as claimed in claim 20, wherein a flexible flat carrier element is provided and covered with bristles and then inserted, under prestressing, into a cutout in the head part, and connected to the head part, such that the carrier element arches.

23. The process as claimed in claim 20, wherein the carrier element covered with bristles is connected to the head part by the hard plastic component of the carrier element being welded ultrasonically to the head part.
- 5
24. The process as claimed in claim 20 or 23, which comprises the operations of injection molding a plurality of sleeves, which are connected to one another by webs, from the hard plastic material, filling interspaces between the sleeves and webs with the soft plastic material during the injection molding process, and introducing clusters of bristles into the sleeves.
- 10
25. The process as claimed in claim 20, wherein the at least one carrier element with a non-planar top surface is provided and covered with bristles and then connected to the head part by being inserted into a cutout which is adapted into the shape of the carrier element and is located in the head part.
- 15
26. The process as claimed in claim 20, wherein the at least one carrier element is connected to the head part by means of ultrasonic welding.
- 20

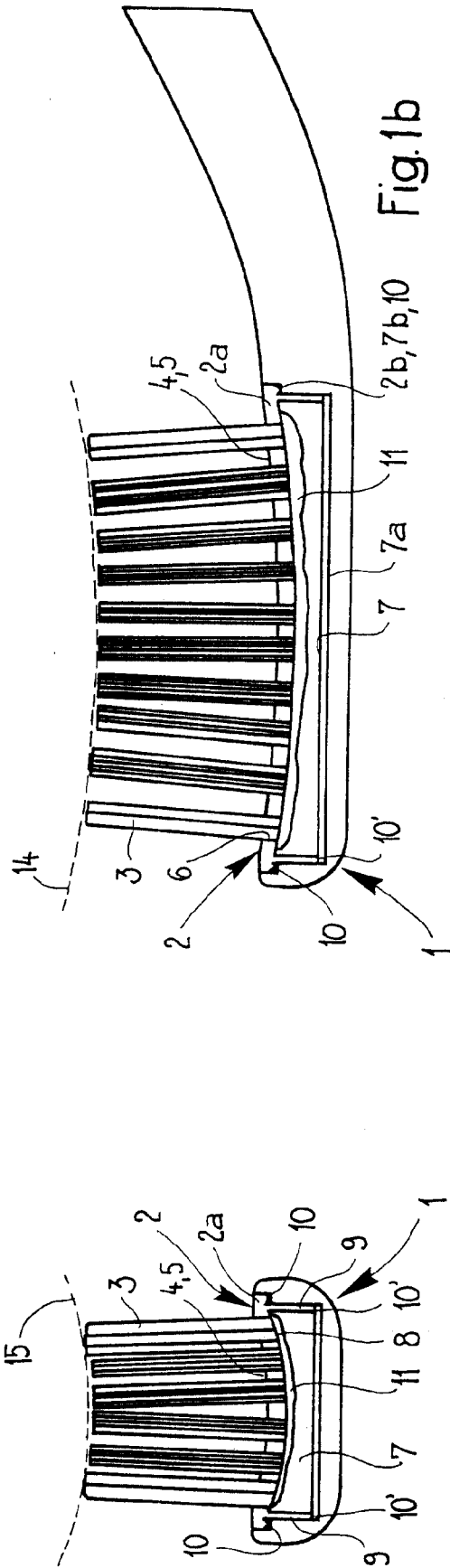

Fig.1a

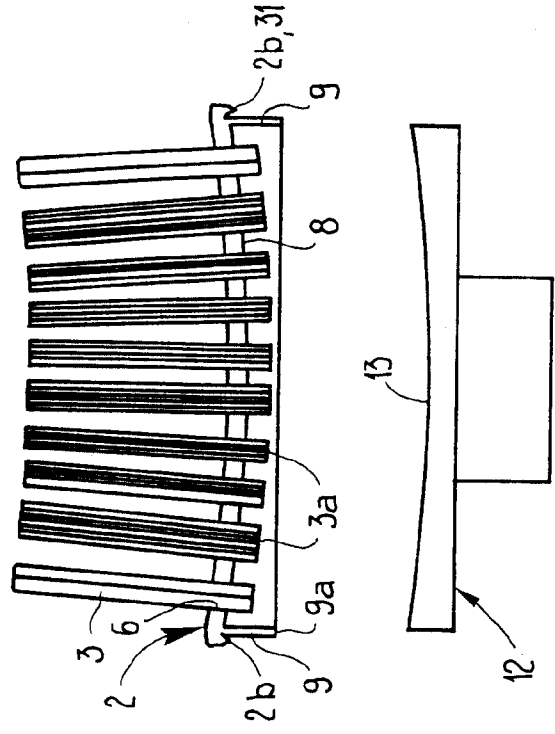

Fig.1c

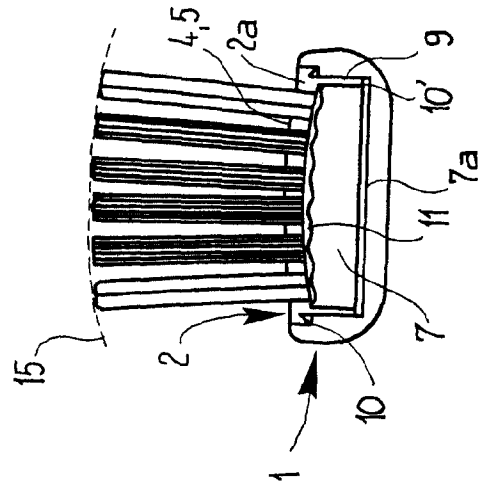

Fig. 2a

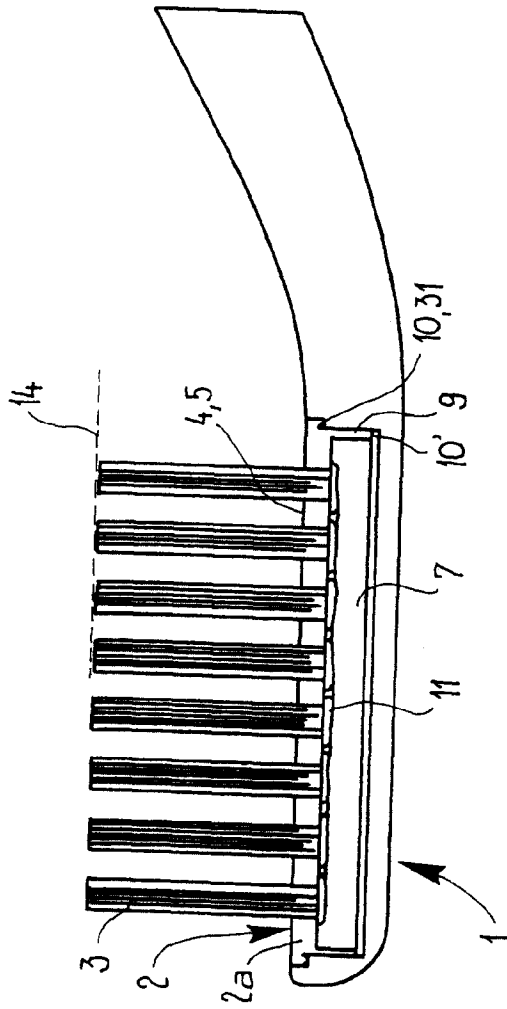

Fig. 2b

3/16

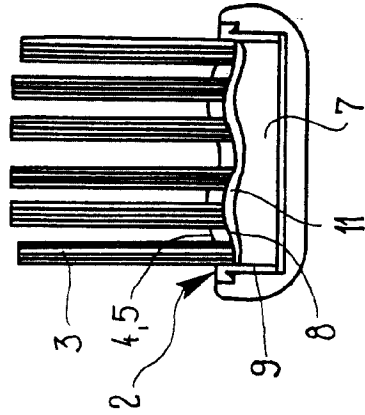

Fig.3b

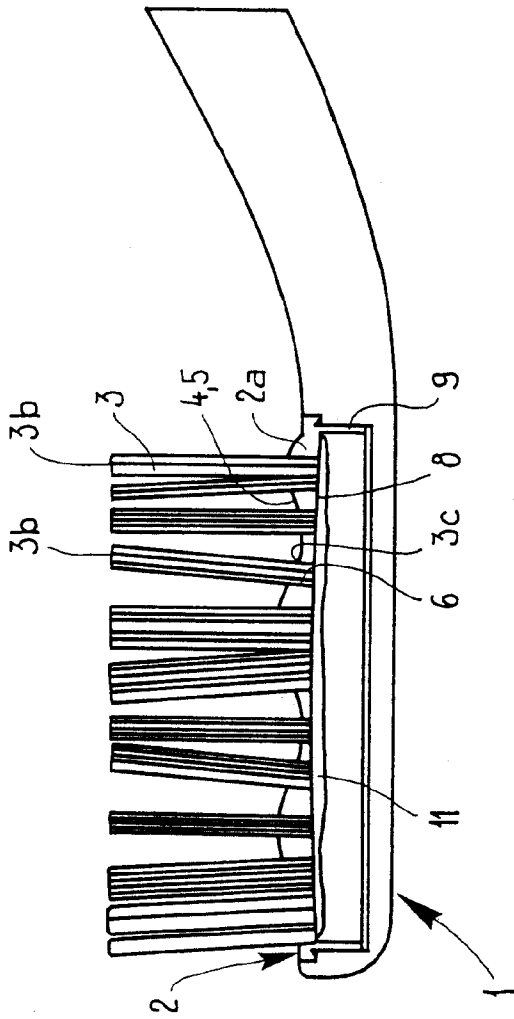

Fig.3a

4/16

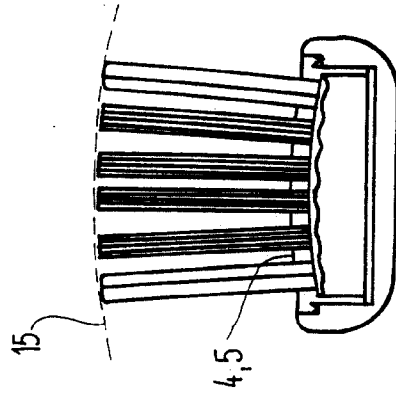

Fig. 4b

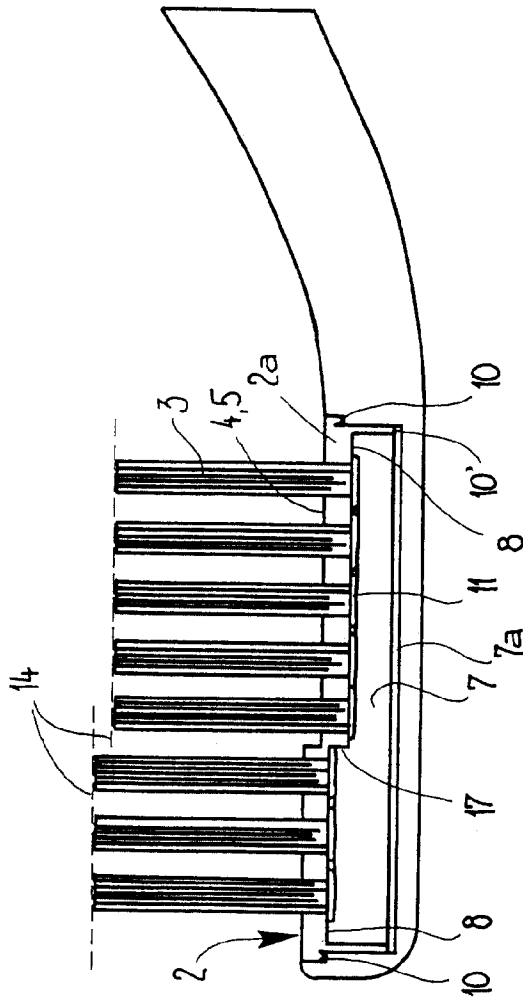

Fig. 4a

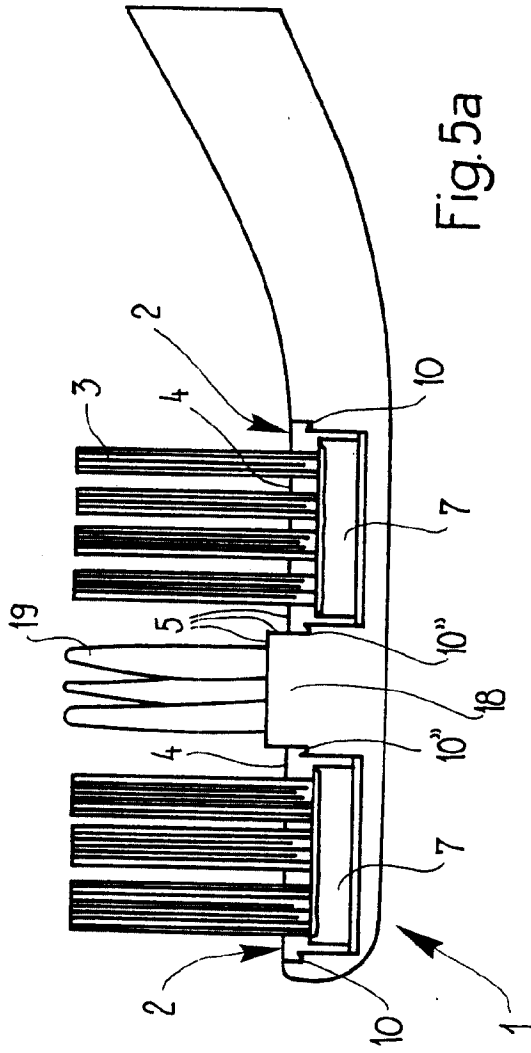

Fig. 5a

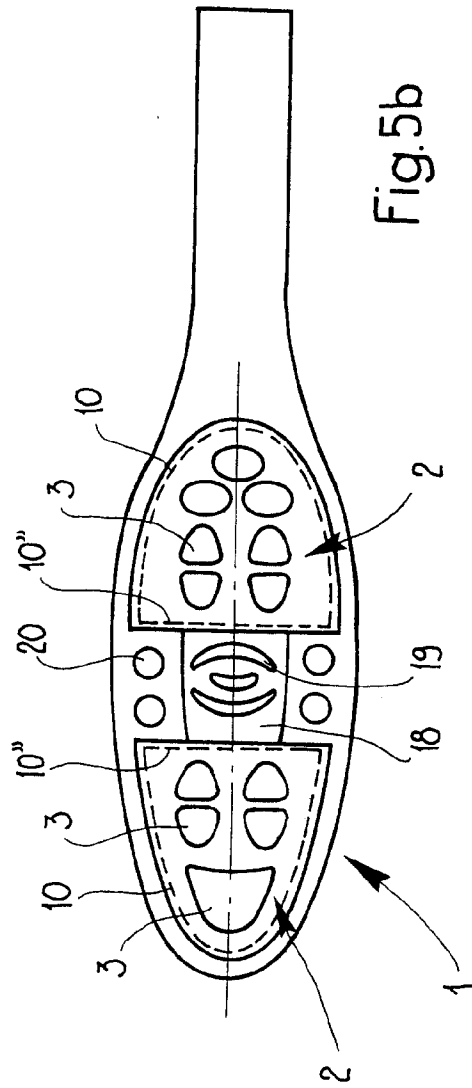

Fig. 5b

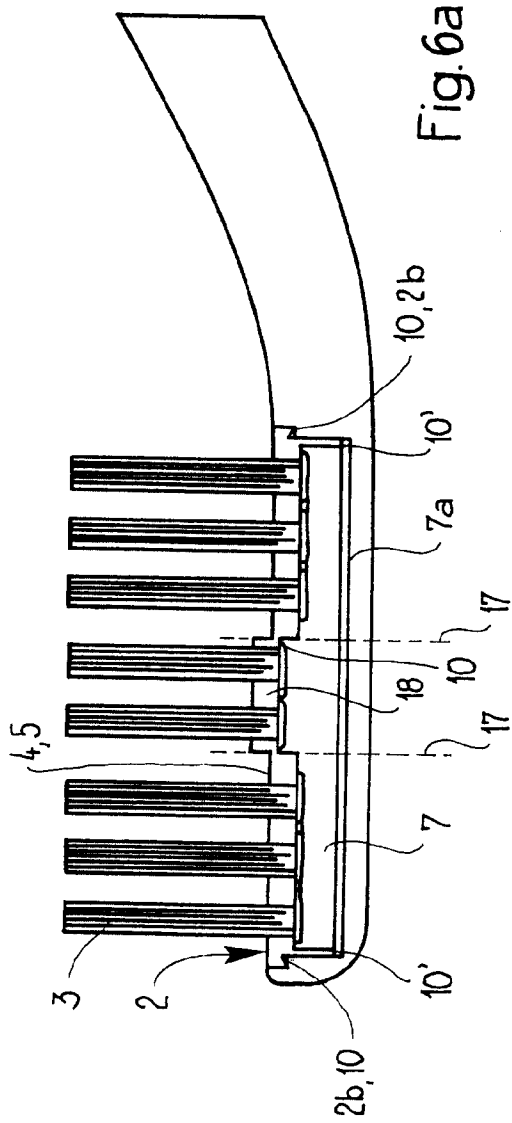

Fig. 6a

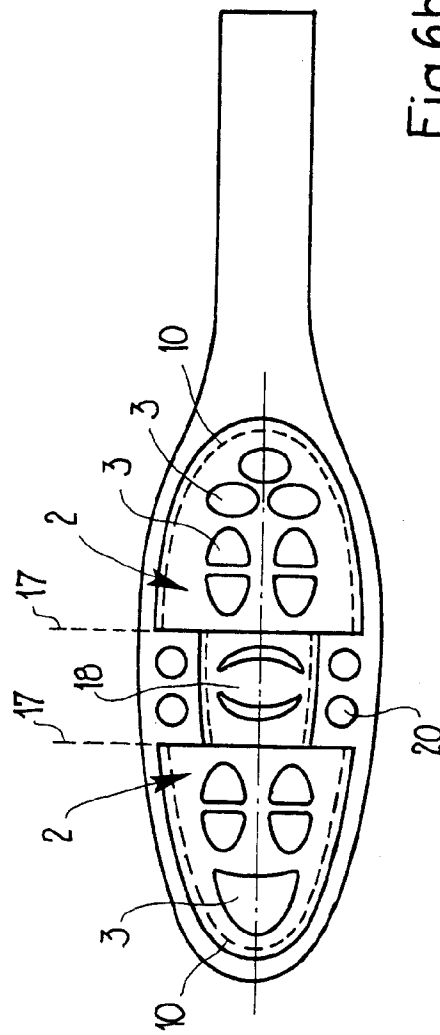

Fig. 6b

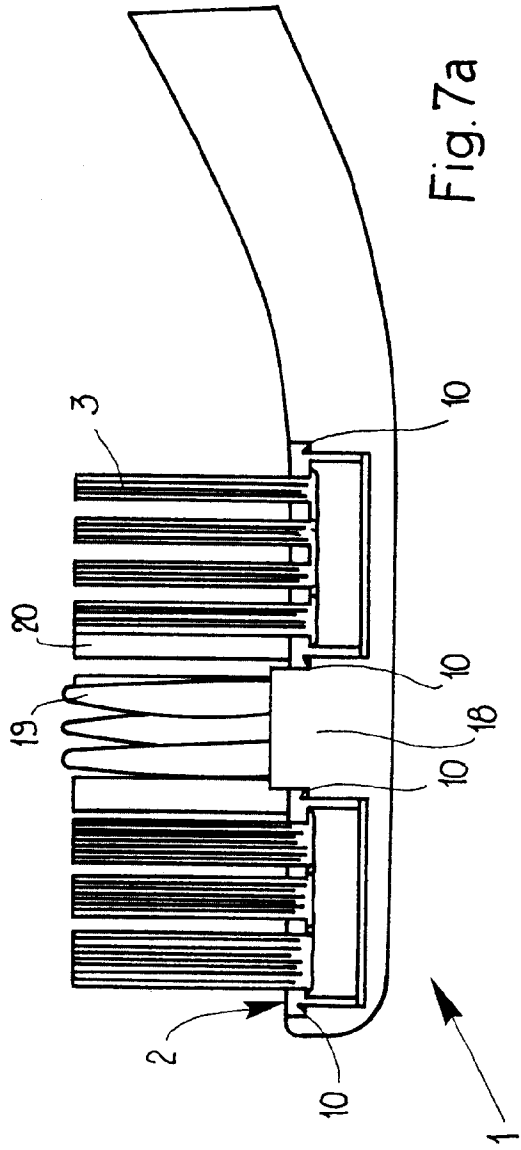

Fig. 7a

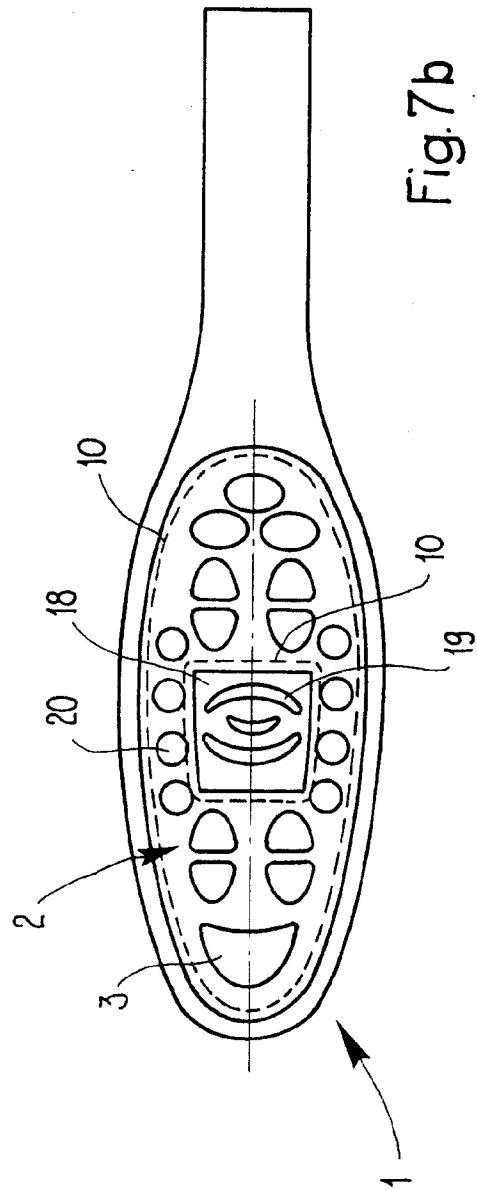

Fig. 7b

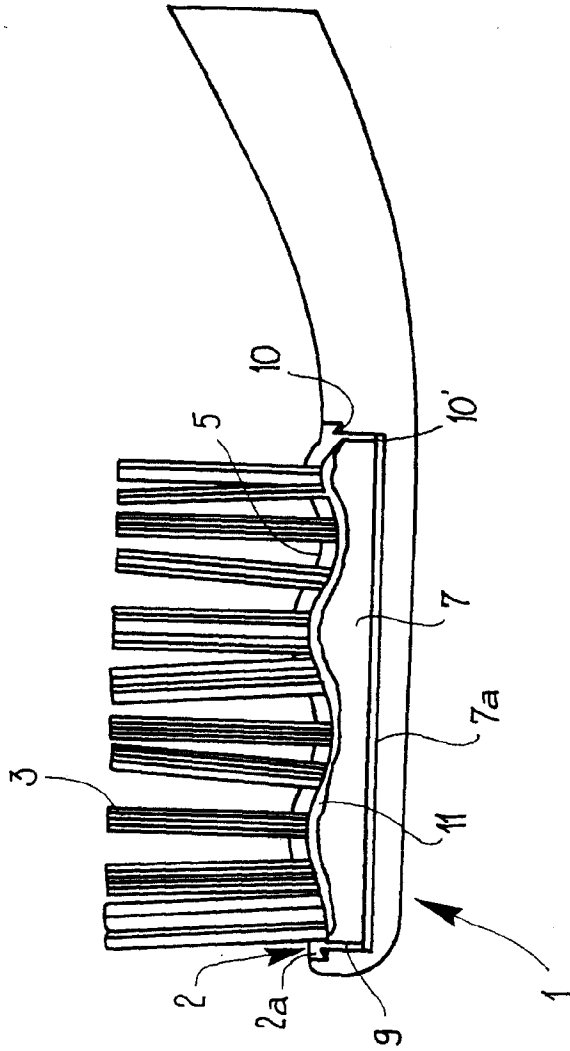

Fig. 8a

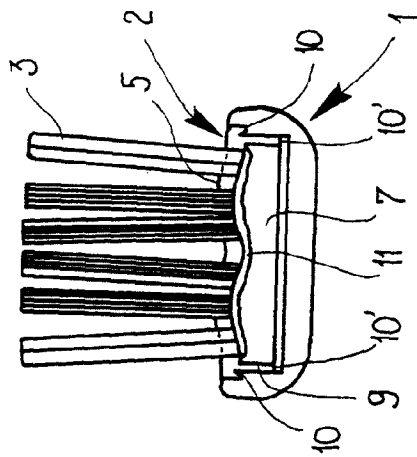

Fig. 8b

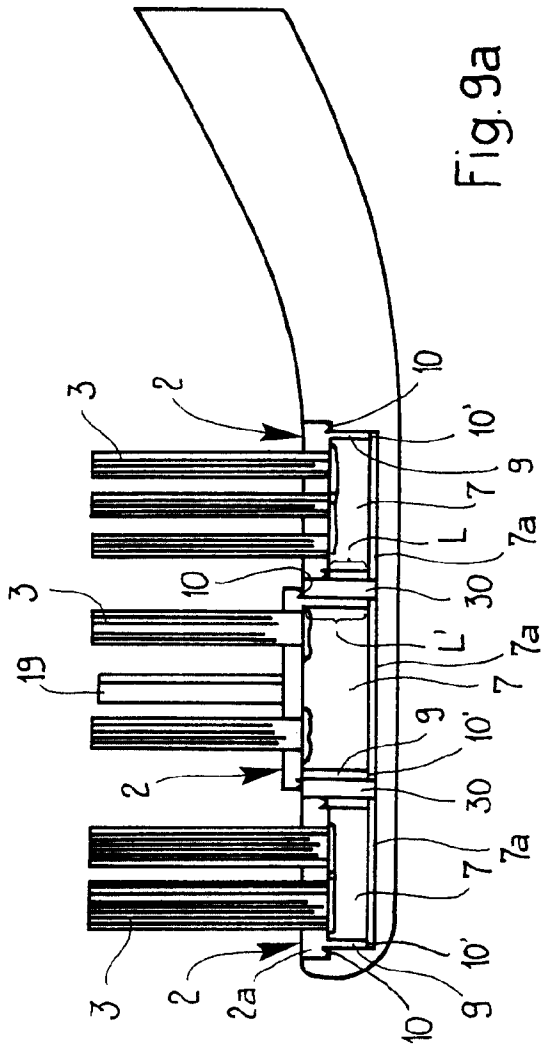

Fig. 9a

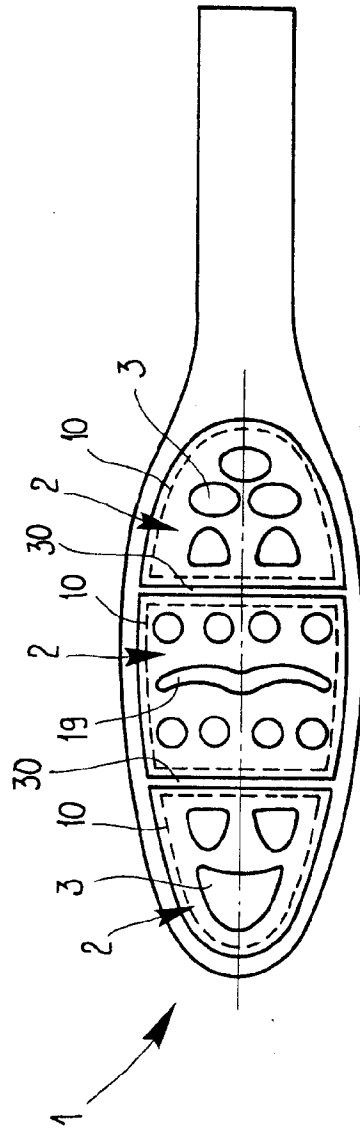

Fig. 9b

10/16

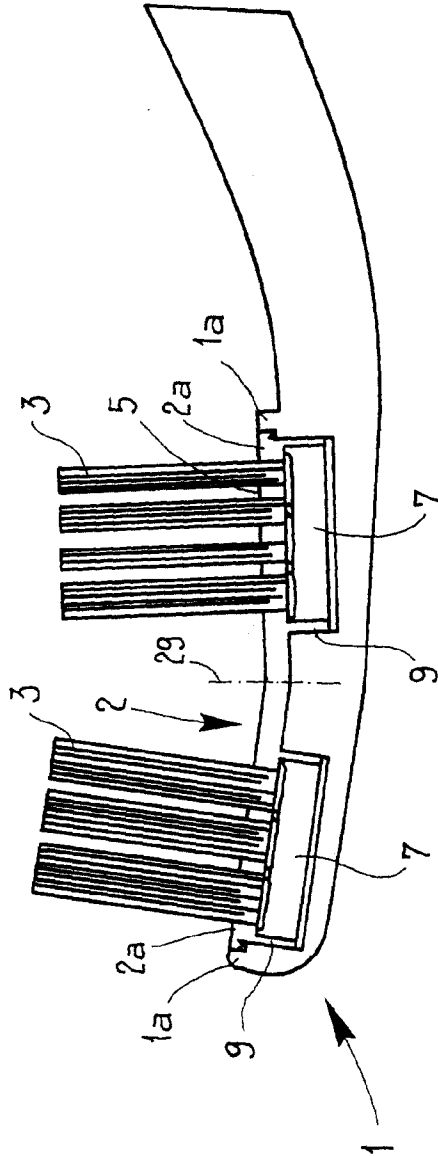

Fig.10

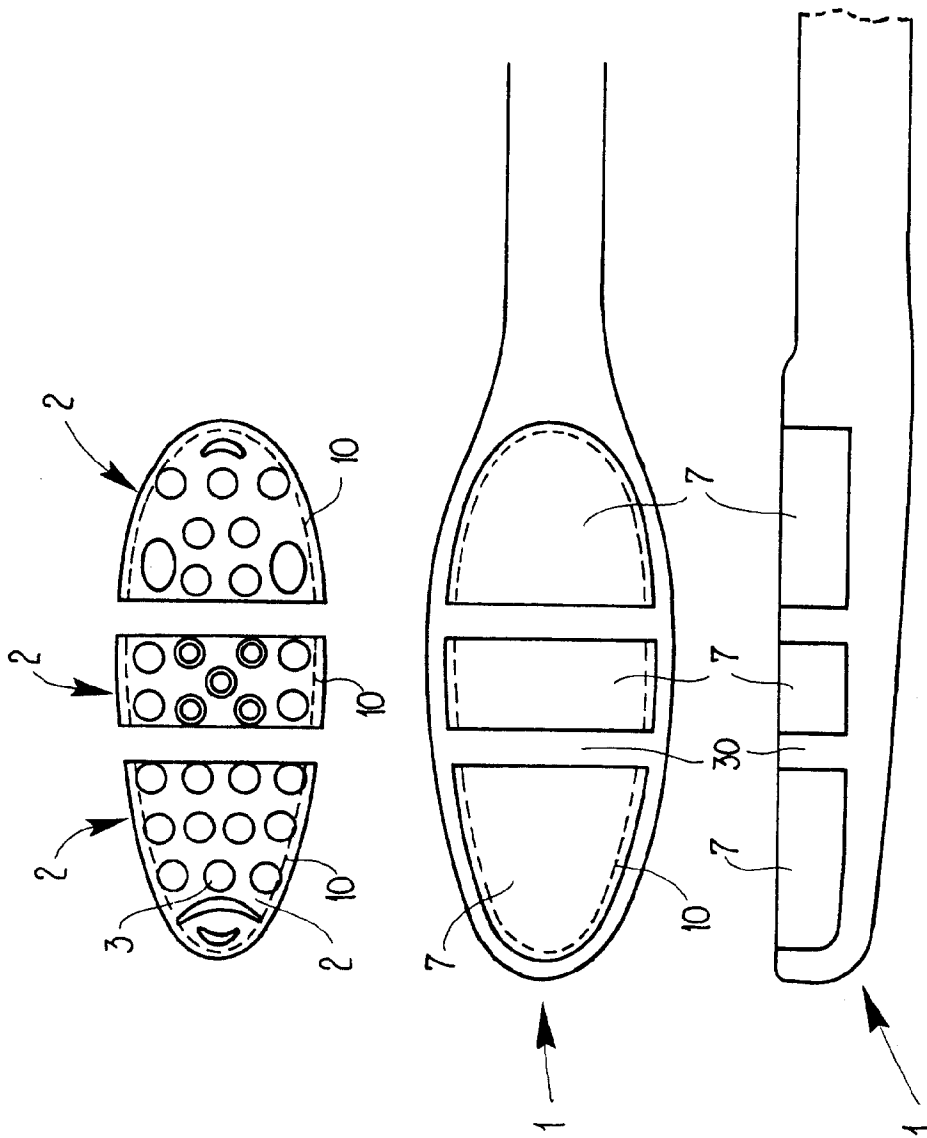

Fig. 11

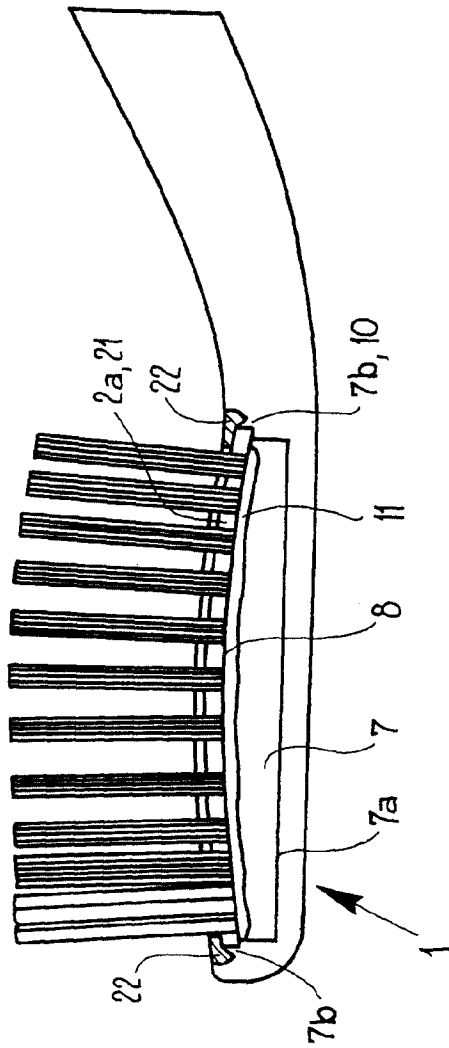

Fig. 12a

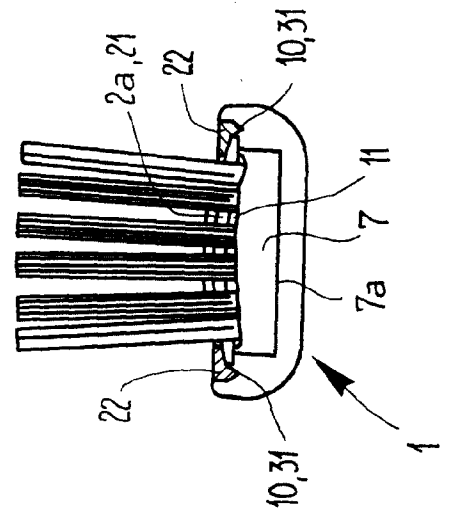
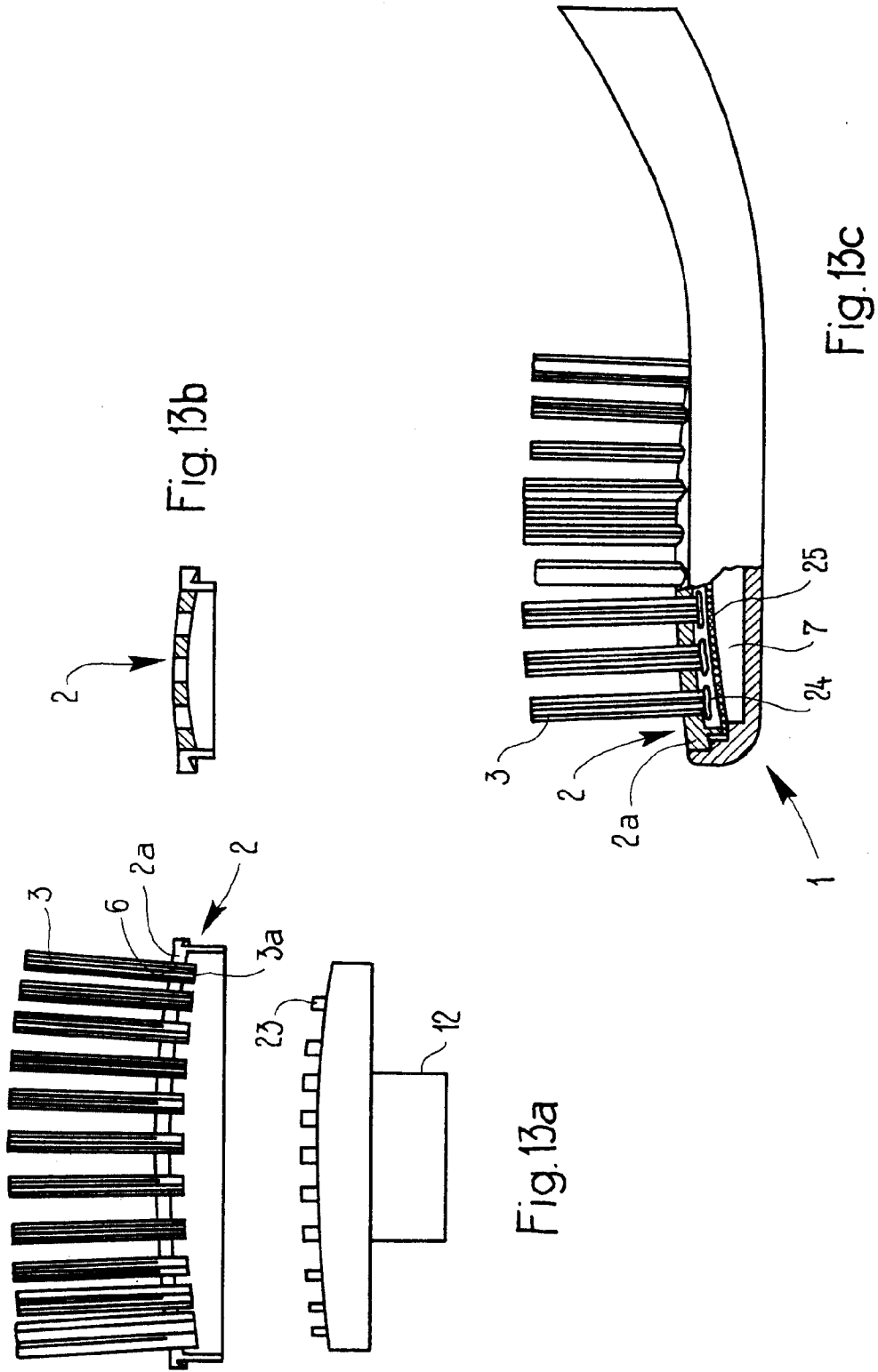

Fig. 12b



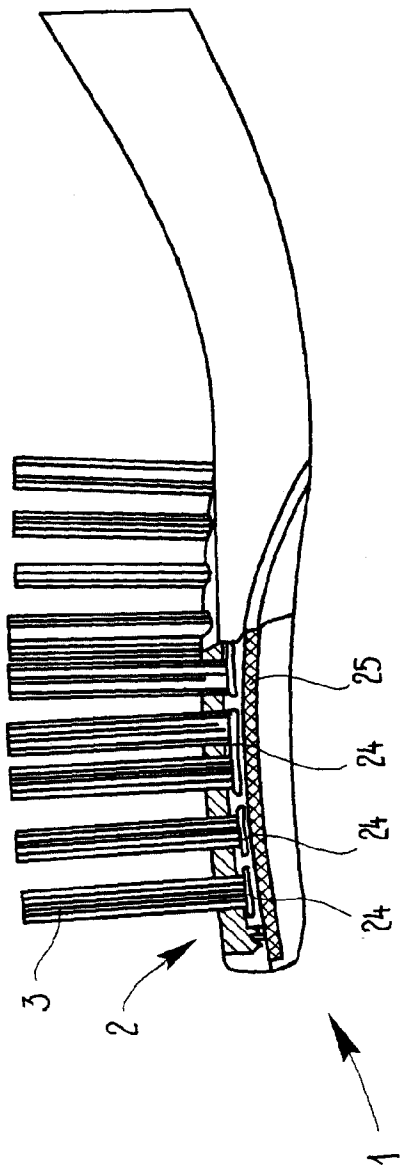

Fig.14

15/16

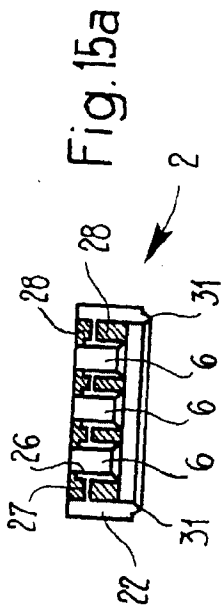

Fig. 15a

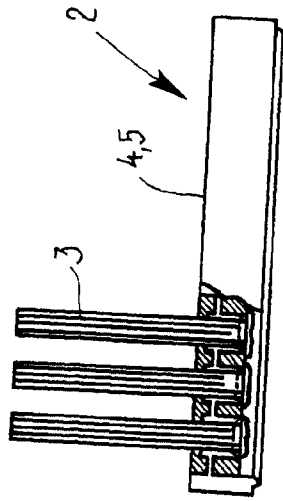

Fig. 15b

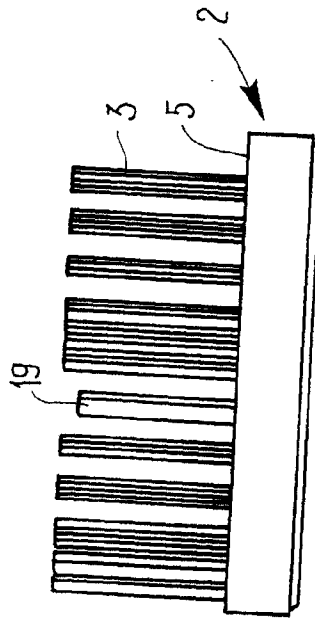

Fig. 15c

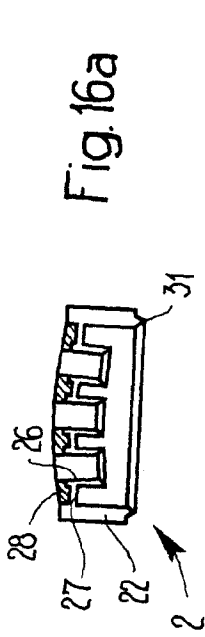

Fig. 16a

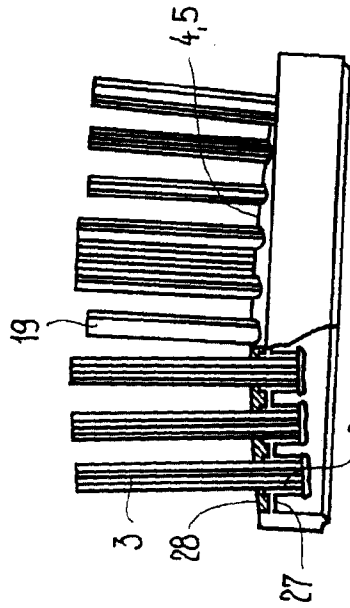

Fig. 16b

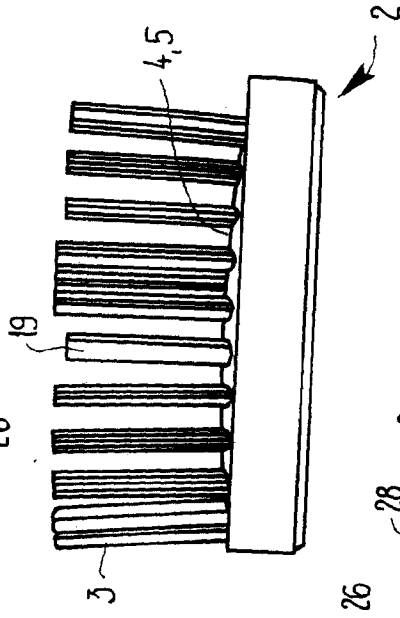

Fig. 16c

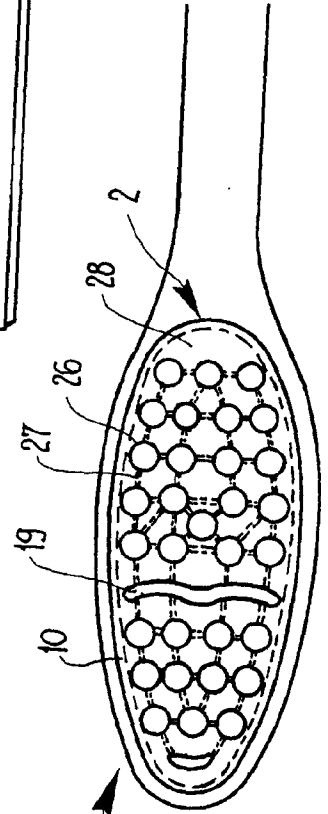

Fig. 15d

16/16

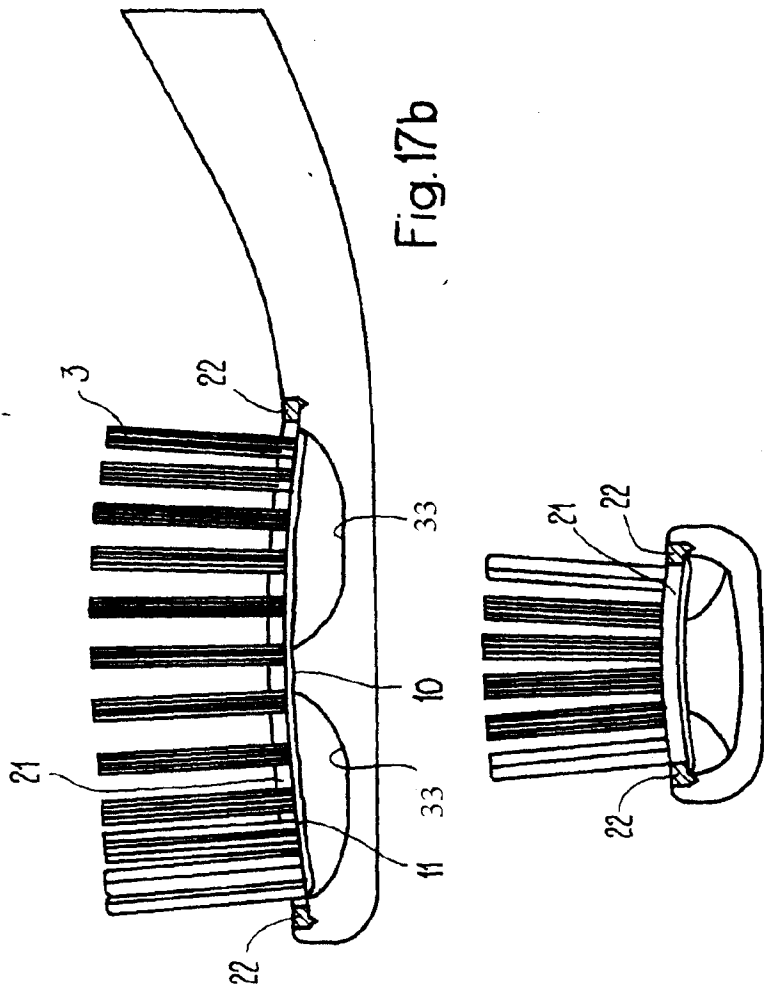

Fig. 17b

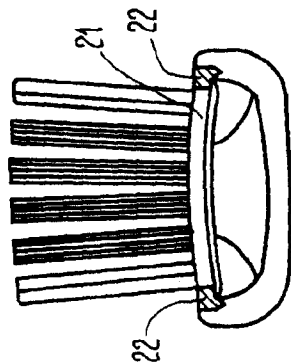

Fig. 17c

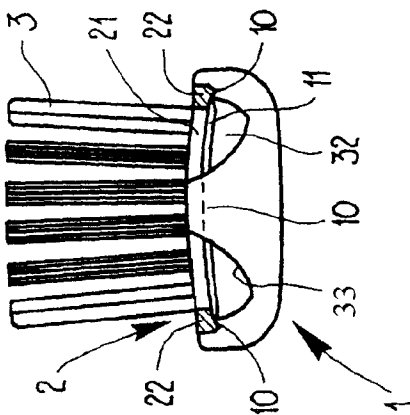

Fig. 17a

