

(19) World Intellectual Property Organization
International Bureau



(43) International Publication Date
9 December 2010 (09.12.2010)

(10) International Publication Number
WO 2010/141603 A3

(51) International Patent Classification:

A61B 5/0476 (2006.01) A61B 5/0484 (2006.01)
A61B 5/0478 (2006.01)

(21) International Application Number:

PCT/US2010/037093

(22) International Filing Date:

2 June 2010 (02.06.2010)

(25) Filing Language:

English

(26) Publication Language:

English

(30) Priority Data:

61/183,408 2 June 2009 (02.06.2009) US

(71) Applicant (for all designated States except US): **PURDUE RESEARCH FOUNDATION** [US/US]; Office Of Technology Commercialization, 1281 Win Hintschel Blvd., West Lafayette, IN 47906 (US).

(72) Inventors; and

(75) Inventors/Applicants (for US only): **RAJDEV, Pooja** [IN/US]; 261 W. Wood St., Apt. #1, West Lafayette, IN 47906 (US). **IRAZOQUI, Pedro** [US/US]; 725 Highland Ave., Lafayette, IN 47907 (US). **WARD, Matthew** [US/US]; 9346 Seascape Drive, Indianapolis, IN 46256 (US). **WORTH, Robert** [US/US]; 545 Barnhill Dirve, Indianapolis, IN 46202 (US).

(74) Agent: **PIROOZI, Hamid, R.**; Maginot, Moore & Beck Llp, Chase Tower, 111 Monument Circle, Suite 3250, Indianapolis, IN 46204 (US).

(81) Designated States (unless otherwise indicated, for every kind of national protection available): AE, AG, AL, AM, AO, AT, AU, AZ, BA, BB, BG, BH, BR, BW, BY, BZ, CA, CH, CL, CN, CO, CR, CU, CZ, DE, DK, DM, DO, DZ, EC, EE, EG, ES, FI, GB, GD, GE, GH, GM, GT, HN, HR, HU, ID, IL, IN, IS, JP, KE, KG, KM, KN, KP, KR, KZ, LA, LC, LK, LR, LS, LT, LU, LY, MA, MD, ME, MG, MK, MN, MW, MX, MY, MZ, NA, NG, NI, NO, NZ, OM, PE, PG, PH, PL, PT, RO, RS, RU, SC, SD, SE, SG, SK, SL, SM, ST, SV, SY, TH, TJ, TM, TN, TR, TT, TZ, UA, UG, US, UZ, VC, VN, ZA, ZM, ZW.

(84) Designated States (unless otherwise indicated, for every kind of regional protection available): ARIPO (BW, GH, GM, KE, LR, LS, MW, MZ, NA, SD, SL, SZ, TZ, UG, ZM, ZW), Eurasian (AM, AZ, BY, KG, KZ, MD, RU, TJ, TM), European (AL, AT, BE, BG, CH, CY, CZ, DE, DK, EE, ES, FI, FR, GB, GR, HR, HU, IE, IS, IT, LT, LU, LV, MC, MK, MT, NL, NO, PL, PT, RO, SE, SI, SK, SM, TR), OAPI (BF, BJ, CF, CG, CI, CM, GA, GN, GQ, GW, ML, MR, NE, SN, TD, TG).

Published:

- with international search report (Art. 21(3))
- before the expiration of the time limit for amending the claims and to be republished in the event of receipt of amendments (Rule 48.2(h))

(88) Date of publication of the international search report:
3 March 2011

(54) Title: ADAPTIVE REAL-TIME SEIZURE PREDICTION SYSTEM AND METHOD

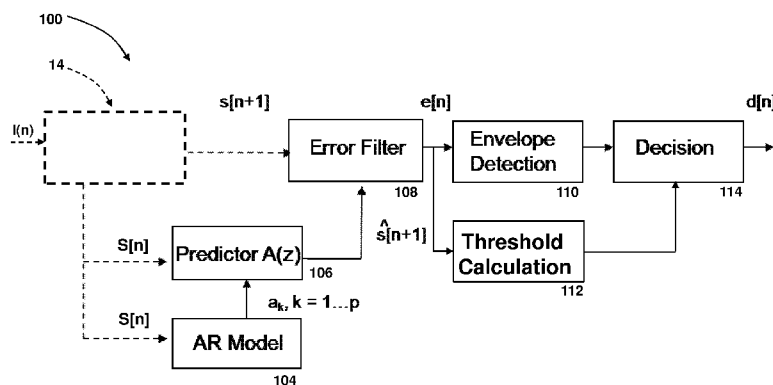

FIG. 2

(57) Abstract: A real-time seizure prediction system. The system includes an implantable electrode configured to transmit an analog neuro-electrophysiological signal from a subject, an analog-to-digital converter configured to convert the analog neuro-electrophysiological signal to a digital neuro-electrophysiological signal based on a predetermined sampling rate, a processor configured to perform following steps during a period defined by the predetermined sampling rate: calculate a plurality of autocorrelation coefficients of the digital neuro-electrophysiological signal for a first predetermined number of samples, calculate a predicted future value of the digital neuro-electrophysiological data based on the plurality of autocorrelation coefficients and the first predetermined number of samples of the digital neuro-electrophysiological data, compare the predicted future value with an actual future value of the digital neuro-electrophysiological data to determine a prediction error, calculate a threshold based on a mean squared value of the prediction error for the first predetermined number of samples and based on a proportionality constant, generate a seizure prediction signal if the prediction error remains above the threshold for a second predetermined number of samples, and a warning device configured to receive the seizure prediction signal and generate an alert.



WO 2010/141603 A3

A. CLASSIFICATION OF SUBJECT MATTER*A61B 5/0476(2006.01)i, A61B 5/0478(2006.01)i, A61B 5/0484(2006.01)i*

According to International Patent Classification (IPC) or to both national classification and IPC

B. FIELDS SEARCHED

Minimum documentation searched (classification system followed by classification symbols)

A61B 5/0476; A61B 5/04; A61N 1/18

Documentation searched other than minimum documentation to the extent that such documents are included in the fields searched

Korean utility models and applications for utility models

Japanese utility models and applications for utility models

Electronic data base consulted during the international search (name of data base and, where practicable, search terms used)

eKOMPASS(KIPO internal) & Keywords: implantable, neuro-electrophysiological signal, autocorrelation

C. DOCUMENTS CONSIDERED TO BE RELEVANT

Category*	Citation of document, with indication, where appropriate, of the relevant passages	Relevant to claim No.
A	US 2003-0158587 A1 (ROSANA ESTELLER et al.) 21 August 2003 See abstract, paragraphs 60-88, and figures 1-4	1-15
A	US 2008-0194981 A1 (MIKA SARKELA et al.) 14 August 2008 See abstract, paragraphs 38-82, and figures 1,2,8a	1-15
A	US 5,311,876 A (DALE E. OLSEN et al.) 17 May 1994 See abstract, column 6 line 62 - column 7 line 7, and figures 1A,1B	1-15
A	US 2007-0067003 A1 (JUSTIN C. SANCHEZ et al.) 22 March 2007 See abstract, paragraphs 49-93, and figure 1	1-15

 Further documents are listed in the continuation of Box C. See patent family annex.

* Special categories of cited documents:

"A" document defining the general state of the art which is not considered to be of particular relevance

"E" earlier application or patent but published on or after the international filing date

"L" document which may throw doubts on priority claim(s) or which is cited to establish the publication date of citation or other special reason (as specified)

"O" document referring to an oral disclosure, use, exhibition or other means

"P" document published prior to the international filing date but later than the priority date claimed

"T" later document published after the international filing date or priority date and not in conflict with the application but cited to understand the principle or theory underlying the invention

"X" document of particular relevance; the claimed invention cannot be considered novel or cannot be considered to involve an inventive step when the document is taken alone

"Y" document of particular relevance; the claimed invention cannot be considered to involve an inventive step when the document is combined with one or more other such documents, such combination being obvious to a person skilled in the art

"&" document member of the same patent family

Date of the actual completion of the international search

10 JANUARY 2011 (10.01.2011)

Date of mailing of the international search report

11 JANUARY 2011 (11.01.2011)

Name and mailing address of the ISA/KR

Korean Intellectual Property Office
Government Complex-Daejeon, 139 Seonsa-ro, Seo-gu, Daejeon 302-701, Republic of Korea

Facsimile No. 82-42-472-7140

Authorized officer

Kim, Sae Byul

Telephone No. 82-42-481-8543



INTERNATIONAL SEARCH REPORT

Information on patent family members

International application No.

PCT/US2010/037093

Patent document cited in search report	Publication date	Patent family member(s)	Publication date
US 2003-0158587 A1	21.08.2003	AU 2002-45110 A1 CA 2425122-A1 EP 1341580 A2 US 2002-0103512 A1 US 2007-0142873 A1 US 6594524 B2 US 7146218 B2 WO 02-49500 A3	01.07.2002 27.06.2002 10.09.2003 01.08.2002 21.06.2007 15.07.2003 05.12.2006 27.06.2002
US 2008-0194981 A1	14.08.2008	DE 102008008826 A1 GB 0802431 D0 GB 2446704 A US 7844324 B2	21.08.2008 19.03.2008 20.08.2008 30.11.2010
US 5,311,876 A1	17.05.1994	None	
US 2007-0067003 A1	22.03.2007	None	