



(11) (21) (C) **2,187,327**
(86) 1995/05/18
(87) 1995/12/07
(45) 2000/12/12

(72) Payne, LeRoy, US

(73) Payne, LeRoy, US

(51) Int.Cl.⁶ B29C 41/06

(30) 1994/05/26 (08/249,744) US

(30) 1994/11/25 (08/345,564) US

(54) **PROCEDE, APPAREIL ET STRUCTURE DE MOULAGE
ROTATIF MULTIAXES**

(54) **MULTIAXIS ROTATIONAL MOLDING METHOD, APPARATUS
AND STRUCTURE**

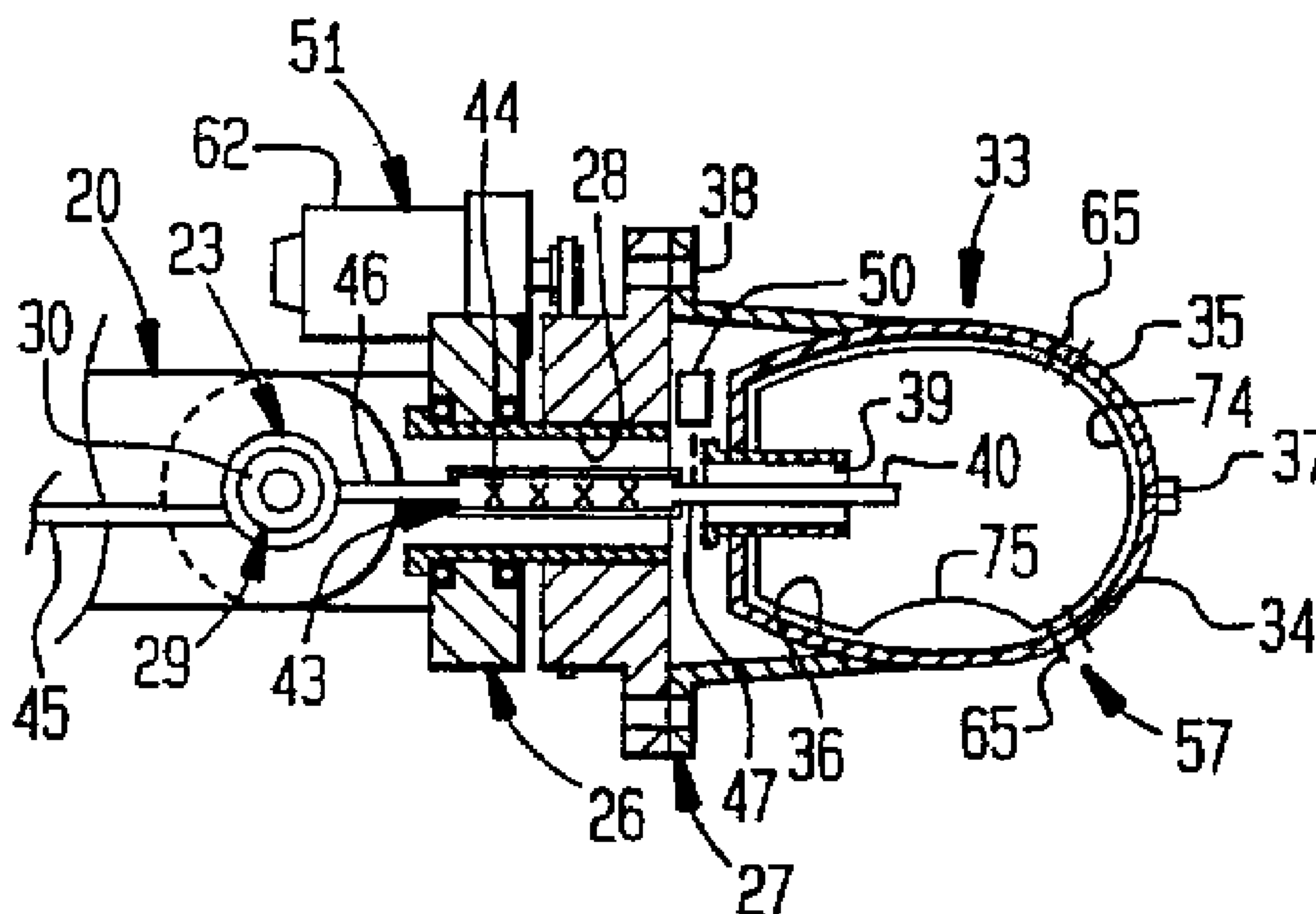

(57) Un procédé de formage continu d'une structure moulée solidairement dans une opération de moulage rotatif multiaxes comprend les étapes consistant à faire tourner un ensemble moule (33) à parties multiples autour d'au moins trois axes. On fait couler un premier mélange polymérisable fraîchement formé sur des surfaces d'une cavité (36) de moule fermée à l'intérieur de l'ensemble moule à parties multiples. L'écoulement du premier mélange sur les surfaces de la cavité du moule et la formation d'une première résine (74) à partir de celui-ci sont contrôlés. On fait couler un second mélange polymérisable (75) fraîchement formé, gélifiant

(57) A method of continuously forming an integrally molded structure in a multi-axis rotational molding operation includes the steps of rotating a multisection mold assembly (33) about at least three axes. A first freshly formed polymerizable mixture is flowed over surfaces of an enclosed mold cavity (36) within the multisection mold assembly. The flowing of the first mixture over the mold cavity surfaces and formation of a first resin (74) therefrom is monitored. A freshly formed rapidly gelling second polymerizable mixture (75) is flowed into the mold cavity to deposit a preselected quantity thereof into contact with a first preselected area





(11) (21) (C) **2,187,327**
(86) 1995/05/18
(87) 1995/12/07
(45) 2000/12/12

rapidement, dans la cavité du moule afin d'en déposer une quantité présélectionnée en contact avec une première zone présélectionnée de la première résine. Une partie du second mélange déposé est extraite à mesure qu'il se gélifie vers une autre zone présélectionnée distante de la première zone présélectionnée, afin de former à partir de celle-ci un élément de support continu (92) d'une intégrité structurelle s'étendant entre les zone présélectionnées de la première résine.

of the first resin. A portion of the deposited second mixture is drawn as it is gelling toward another preselected area remote from the first preselected area to form therefrom a continuous support member (92) with structural integrity extending between the preselected areas of the first resin.



INTERNATIONAL APPLICATION PUBLISHED UNDER THE PATENT COOPERATION TREATY (PCT)

<p>(51) International Patent Classification⁵ : B29C 45/33</p>	<p>A1</p>	<p>(11) International Publication Number: WO 95/32854 (43) International Publication Date: 7 December 1995 (07.12.95)</p>
<p>(21) International Application Number: PCT/US95/06301 (22) International Filing Date: 18 May 1995 (18.05.95) (30) Priority Data: 249,744 26 May 1994 (26.05.94) US 345,564 25 November 1994 (25.11.94) US (60) Parent Application or Grant (63) Related by Continuation US 345,564 (CIP) Filed on 25 November 1994 (25.11.94) (71)(72) Applicant and Inventor: PAYNE, LeRoy [US/US]; 3300 Nicholas Lane, Molt, MT 59057 (US). (74) Agent: URBAN, Arthur, L.; P.O. Box 4045, Red Lodge, MT 59068 (US).</p>	<p>(81) Designated States: AM, AT, AU, BB, BG, BR, BY, CA, CH, CN, CZ, DE, DK, EE, ES, FI, GB, GE, HU, JP, KE, KG, KP, KR, KZ, LK, LR, LT, LU, LV, MD, MG, MN, MW, MX, NO, NZ, PL, PT, RO, RU, SD, SE, SI, SK, TJ, TT, UA, US, UZ, VN, European patent (AT, BE, CH, DE, DK, ES, FR, GB, GR, IE, IT, LU, MC, NL, PT, SE), OAPI patent (BF, BJ, CF, CG, CI, CM, GA, GN, ML, MR, NE, SN, TD, TG), ARIPO patent (KE, MW, SD, SZ, UG).</p> <p style="text-align: right; font-size: 2em;">2187327</p> <p>Published <i>With international search report.</i> <i>With amended claims and statement.</i></p>	

(54) Title: MULTIAxis ROTATIONAL MOLDING METHOD, APPARATUS AND STRUCTURE

(57) Abstract

A method of continuously forming an integrally molded structure in a multiaxis rotational molding operation includes the steps of rotating a multisection mold assembly (33) about at least three axes. A first freshly formed polymerizable mixture is flowed over surfaces of an enclosed mold cavity (36) within the multisection mold assembly. The flowing of the first mixture over the mold cavity surfaces and formation of a first resin (74) therefrom is monitored. A freshly formed rapidly gelling second polymerizable mixture (75) is flowed into the mold cavity to deposit a preselected quantity thereof into contact with a first preselected area of the first resin. A portion of the deposited second mixture is drawn as it is gelling toward another preselected area remote from the first preselected area to form therefrom a continuous support member (92) with structural integrity extending between the preselected areas of the first resin.

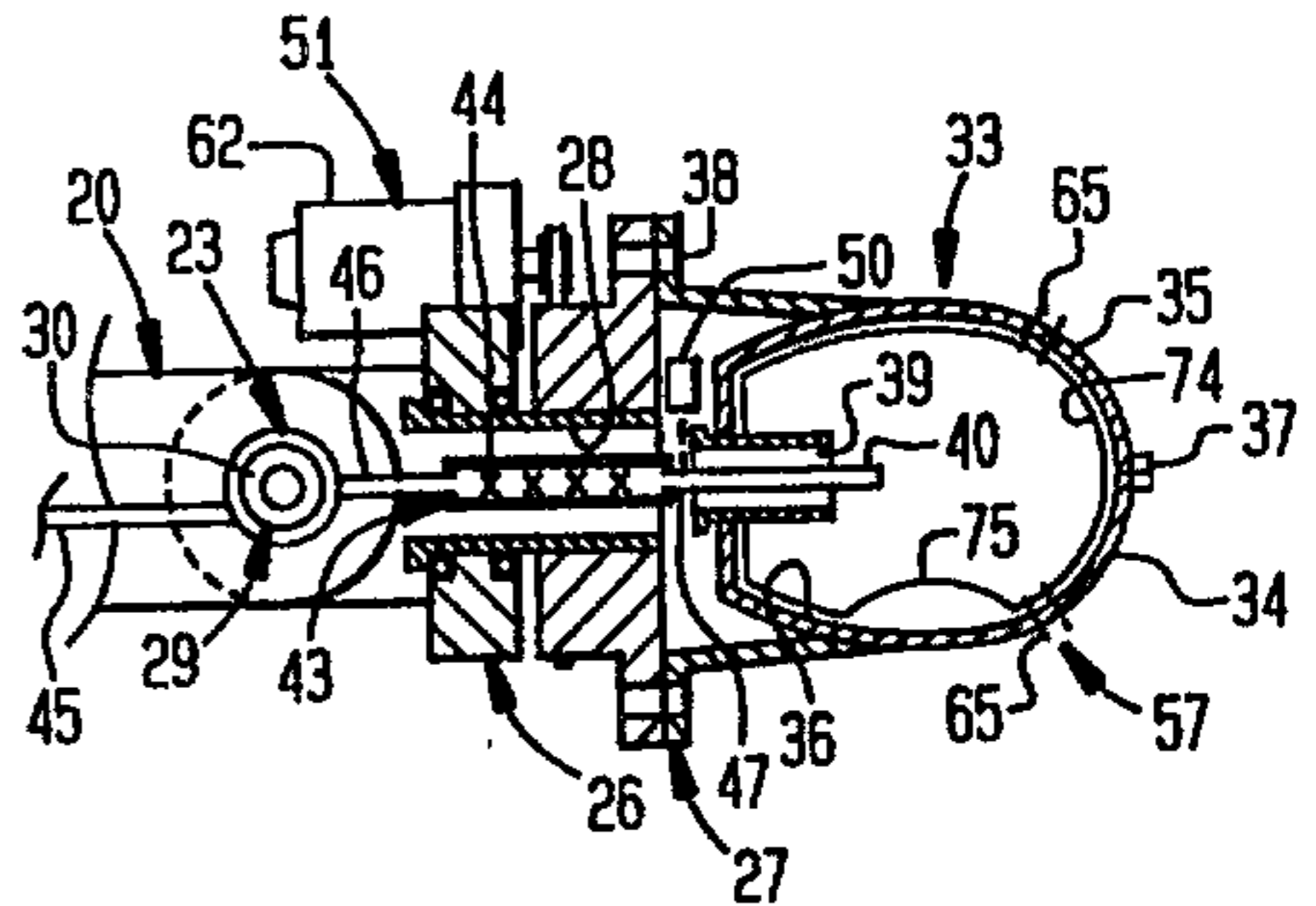

5

MULTIAXIS ROTATIONAL MOLDING

10

METHOD, APPARATUS AND STRUCTURE

15

This invention relates to a novel molding method and apparatus and more particularly relates to a new multiaxis rotational molding method and apparatus.

20

The production of man-made plastic and resin articles is an industry that utilizes a high degree of automatically controlled continuous processing. However, for units of appreciable size, batch processing still is the rule rather than the exception. For example, in the production of fiberglass structures such as boats, it is customary to construct the hulls by hand, building on an open mold in which a plurality of resin and fiberglass layers are sequentially laminated or a plurality of mixed resin/chopped fiber coatings are applied over the mold.

25

30

Such hand building procedures require a great amount of labor, supervision and continuous inspection to insure that a reasonable level of quality is achieved. This greatly increases the cost of the product.

35

The applicant's earlier patents listed above provide a novel method and apparatus for producing both large and small molded

structures continuously. The apparatus includes unique combinations of components to produce a wide variety of different products. Achieving this capability requires a major capital investment. Also, personnel to utilize the broad parameters of the apparatus normally are highly trained and experienced.

The present invention provides a novel molding method and apparatus which not only overcome the deficiencies of present technology but also provide features and advantages not found in earlier expedients. The multiaxis rotational molding method and apparatus of the invention provide a simple inexpensive means for the production of uniform high quality products efficiently.

The multiaxis rotational molding apparatus of the present invention is simple in design and can be produced relatively inexpensively. Commercially available materials and components can be utilized in the manufacture of the apparatus. Conventional metal fabricating procedures can be employed by semi-skilled labor in the manufacture of the apparatus. The apparatus is durable in construction and has a long useful life with a minimum of maintenance.

The apparatus of the invention can be operated by individuals with limited mechanical skills and experience. High quality molded structures can be produced by such persons safely and efficiently with a minimum of supervision.

The molding method and apparatus of the invention can be modified to mold a wide variety of new structures. Variations both in product configuration and composition can be attained simply and conveniently with the method and apparatus of the invention. Even with such variations, uniformity and quality of product dimensions and shapes still are maintained without difficulty.

A novel method of the present invention for forming an integrally molded structure includes the steps of rotating a multisection mold assembly about at least three axes and flowing a first freshly formed polymerizable mixture over surfaces of an enclosed mold cavity within the mold assembly. The flowing of the first mixture over the mold cavity surfaces and formation of a first resin therefrom are monitored.

A freshly formed rapidly gelling second polymerizable mixture is flowed into the mold cavity to deposit a preselected

quantity thereof into contact with a first preselected area of the first resin. A portion of the deposited second mixture is drawn as it is gelling toward another preselected area remote from the first preselected area.

5 The second mixture is drawn at a rate to form therefrom a continuous support member with structural integrity extending between the preselected areas of the first resin. The flowing of the second mixture and the drawing of a portion thereof to form a continuous support member are monitored.

10 The above steps may be repeated to form a plurality of spaced continuous support members creating an internal framework within an integrally molded structure of the invention. Preselected quantities of the second mixture are sequentially deposited on preselected areas with a portion of each deposit being drawn immediately toward an area previously selected to be the recipient of the opposite end of the support member being drawn. In the same way, each additional support member is drawn until the internal framework is completed.

20 The drawing of the portion of the deposited second mixture across the mold cavity may be accomplished by gravity or more advantageously by creating an electrical field along a line bisecting the mold cavity as will be described hereinafter.

25 Advantageously, a third freshly formed polymerizable mixture is flowed over the second resin support members and the first resin within the mold cavity. The flowing of the third mixture over the mold cavity surfaces and the formation of the third resin therefrom are monitored.

30 The rotation of the mold assembly is continued throughout the molding operation. Simultaneously, each axis rotation of the mold assembly is monitored individually. Also, the monitored flowing of each mixture and the monitored formation of each resin with each monitored axis rotation in a preselected profile are coordinated to form an integrally molded structure of the first, second and third resins.

35 The mold sections of the mold assembly are separated after the integrally molded structure has achieved structural integrity within the mold cavity. The structure is removed from the separated mold sections and the steps are repeated to form a multiplicity of the molded structures on a continuing basis.

40 The method of the invention may include the preconditioning

of raw material prior to forming the first, second and/or third
polymerizable mixtures therewith. Also, the incorporation of a
major proportion of a solid additive material to at least one of
the polymerizable mixtures is advantageous. In addition, air or
5 an inert gas may be entrained within the product during the
molding operation.

Benefits and advantages of the novel multiaxis rotatable
molding method and apparatus of the present invention will be
apparent from the following description and the accompanying
10 drawings in which:

Figure 1 is a view in perspective of one form of multiaxis
rotatable molding apparatus of the invention;

Figure 2 is a side view in section of the molding and mixing
portions of the apparatus shown in Figure 1 taken along line 2-2
15 thereof;

Figure 3 is a schematic illustration in section of the mold
cavity shown in Figure 2 during a subsequent molding step with
the apparatus of the invention;

Figure 4 is a schematic illustration in section of the mold
cavity shown in Figure 2 in a different orientation during
20 another step in a molding method of the invention;

Figure 5 is a schematic illustration in section of the mold
cavity shown in Figure 4 in another orientation during a further
step in a molding method of the invention;

Figure 6 is a schematic illustration in section of a
structure of the invention;

Figure 7 is a schematic illustration in section of the mold
cavity shown in Figure 2 in another molding method of the
invention;

Figure 8 is a schematic illustration in section of the mold
cavity shown in Figure 7 during a subsequent step in a molding
method of the invention;

Figure 9 is a schematic illustration in section of the mold
cavity shown in Figure 2 in a different molding method of the
35 invention;

Figure 10 is a schematic illustration in section of the mold
cavity shown in Figure 9 during a further step in a molding
method of the invention;

Figure 11 is a schematic illustration in section of the mold cavity shown in Figure 2 in an additional molding method of the invention; and

Figure 12 is a schematic illustration in section of another structure of the invention.

As shown in Figures 1 and 2 of the drawings, one form of multiaxis rotational molding apparatus 11 of the present invention includes a support portion 12, a molding portion 13, a mixing portion 14 and a control portion 15.

The support portion 12 of the multiaxis rotational molding apparatus 11 of the invention includes an arm member 20 disposed in a generally horizontal orientation. One end 21 of arm member 20 extends from an upstanding supporting section 22. A transverse supporting member 23 extends from adjacent an opposite end 24 of the arm member 20. Advantageously, the support portion 12 includes a base section 25 from which the upstanding supporting section 22 extends.

The molding portion 13 of the rotational molding apparatus 11 includes a plurality of mold supporting assemblies 26. The mold supporting assemblies are rotatably mounted along the length of the transverse supporting member 23 in a spaced relationship.

Each mold supporting assembly 26 includes an independently rotatable mold connector section 27. Each mold supporting assembly also includes a central passage 28 therethrough. The central passage extends from a rotatable connection 29 with the transverse supporting member 23 and through the mold connector section 27.

Advantageously, the rotatable connection 29 of the transverse supporting member 23 and each mold supporting assembly 26 includes a rotatable coupling shown as swivel coupling 30. The arm member 20 advantageously also may include one or more pivotal connections along its length.

The molding portion 13 further includes a plurality of mold assemblies 33. Each mold assembly includes at least two separable mold sections 34,35. The assembled mold sections form a substantially enclosed cavity 36. Connecting means shown as clamps 37 selectively secure the mold sections 34,35 together. Also, connecting means 38 secure the assembled mold sections to mold connector section 27. Each mold assembly 33 advantageously includes a vent 39 preferably disposed concentrically with a

probe member 40.

The mixing portion 14 of the multiaxis rotational molding apparatus 11 of the present invention includes an elongated mixing section 43 associated with each mold assembly 33. Each mixing section 43 extends axially within the central passage 28 through each mold supporting assembly 26 adjacent the mold connector section 27. Each mixing section 43 also includes a plurality of deflector sections 44 disposed along the length thereof.

A plurality of inlet conduits 45 that extend along the arm member 20 and the transverse supporting member 23 are operatively connected to an inlet end 46 of each mixing section 43. Advantageously, the inlet conduits extend through the rotatable connections 29 with the mold supporting assemblies 26.

A hollow probe member 40 with an orifice 41 extends from an outlet end 47 of each mixing section 43 into mold cavity 36 of the adjacent mold assembly 33. The probe member 40 preferably is axially movable within mold cavity 36 by drive 50.

The control portion 15 of the molding apparatus 11 of the present invention includes actuating means including drive means 51,52 for each mold assembly. One drive means 51 rotates each mold connector section 27 and the mold assembly 33 affixed thereto. Another drive means 52 rotates each mold supporting assembly 26 and the mold assembly 33 affixed thereto with respect to the transverse supporting member 23.

The control portion 15 also includes programmable memory means 55, coordinating means 56, monitoring means 57 and circuitry therefor. The drive means 51,52 advantageously includes gear motors 62, chains 63 and sprockets 64 connected thereto. Preferably, the gear motors are variable speed motors. The actuating means may activate other components such as pumps, valves, drives, etc.

Arm member 20 and transverse supporting member 23 advantageously include a longitudinal passage 32 in which inlet conduits 45 and control circuitry are disposed. Preferably, the monitoring means 57 includes optical fibers 65 extending through the respective mold sections 34,35 as shown in Figure 2.

The coordinating means 56 advantageously includes a process controller 59 that initiates changes in the flows of materials and speeds of drives for each mold assembly to bring variations

therein back to the respective rates specified in the programs present in the memory 55. This coordination commonly is achieved through the transmission of information such as digital pulses from the monitors and/or sensors at the control components to the process controller 59.

The operating information is compared with the preselected programming parameters stored in the memory 55. If differences are detected, instructions from the controller change the operation of the components to restore the various operations to the preselected processing specifications.

In the use of the multiaxis rotational molding apparatus 11 of the present invention, the designs of the structures desired first are established. Then, each design is programmed into the memory 55.

To start the operation of the apparatus 11, buttons and/or switches 67 of a control panel 68 are depressed to activate the memory 55 and the other components of the control portion 15. The coordinating means 56 energizes drive means 51,52.

Also, pumps, valves and monitors (not shown) are energized by the coordinating means 56 in the preselected sequences of the program stored in the memory 55. This causes the raw materials in reservoirs 70,71,72 to advance along the inlet conduits 45 toward the respective mixing section 43 associated with each mold assembly. For example, to mold a structure including a polyurethane resin, reservoir 70 may contain a liquid reactive resin forming material, reservoir 71 a particulate solid recyclable material and reservoir 72 and other reservoirs - colors, catalysts, etc. as required.

To produce high quality molded structures of the invention, it is important that the raw material delivered to each mixing section 43 be uniform in volume and composition. This can be facilitated by providing a continuous flow of raw materials to each mixing section and the immediate transfer of the mixture therefrom onto the cavity surface of the mold assembly 33. However, the volume of the mixture delivered will vary depending upon the particular incremental area being covered at any instant. Also, the delivery to a particular mold assembly will be terminated completely when a molded structure is being removed from that assembly.

Advantageously, a separate bypass conduit (not shown) is utilized from the end of each inlet conduit 45 at a point adjacent a particular mixing section 43 back to the respective reservoir. This construction provides for the delivery of a freshly formed uniform mixture from the mixing section even though the distance is considerable between the reservoirs and the mixing section which is located adjacent each mold assembly 33. The control portion 15 coordinates the operation of the various system components so the required formulation can flow onto the desired areas of the mold cavity.

Rotation of each mold assembly 33 about its longitudinal axis and rotational movement of the mold assembly about rotatable connection 29 perpendicular to its longitudinal axis are started and continue while each freshly formed polymerizable mixture is transferred from its mixing section 43 into the cavity 36 of each mold assembly 33. The double axis rotational movement and any arcuate movement are continued to complete the flow of the mixtures over all areas being covered. All movements are controlled within the parameters stored in the memory 55.

For particular structures, the movements about the respective axes may be continuous and/or intermittent at changing rates. Also, it may be desirable to provide arcuate rotation, that is, movement about an arc such as a rocking motion. Monitors 57 located within each mold assembly 33 signal the process controller 59 when each polymerizable mixture has been distributed over preselected areas of the respective mold cavity so the controller can initiate the next step of the molding method.

After the first polymerizable mixture has been flowed over the cavity surface and a first resin layer 74 has formed, the second polymerizable mixture is delivered through probe member 40 into mold cavity 36 with the mold assembly 33 at rest. This allows a preselected quantity 75 of the second polymerizable mixture to collect in the lowest area of the mold cavity as shown in Figure 2. When the viscosity of the mixture has increased to a preselected level, the mold assembly is rotated 180 degrees so that the mixture is now stuck at the highest area of the cavity and mold rotation is stopped. Gravitational force on the mixture

causes a portion thereof to be drawn downward at a rate to form a continuous support member 76 that terminates at an area on the opposite side of the mold cavity. Curing of the support member provides structural integrity as shown in Figure 3.

5 To form a support member with a different orientation, the mold assembly is rotated about its axes to position a preselected area 82 of the first resin layer 74 at the lowest point of the cavity. A preselected quantity of the second polymerizable mixture flowing into the cavity collects in the bottom (Figure 10 4). When the viscosity has increased to a preselected level, the mold assembly is rotated to place a preselected area for the opposite end of the support member directly below the mixture. Gravitational force draws a portion of the mixture downward to form a support member which cures to provide structural integrity 15 (Figure 5). Figure 6 illustrates a tank 78 with an outer layer 79 and a plurality of support members 80 forming a supporting framework 81 which can be produced using the above methods.

In Figure 7, a movable flexible probe member 83 is employed to deposit a preselected quantity of a second polymerizable 20 mixture in a preselected area 82 of a first resin layer 84. Thereafter, the tip of the probe member is moved away from the cavity surface at a rate to form a support member 85. Terminating the flow of the mixture partway will produce a support member which can serve as a stop against over compression 25 of the upper surface of the outer layer (Figure 8).

Figures 9 and 10 illustrate a preferred method in which an electrical field is created along a line bisecting the mold cavity. For example, a positive charge can be created in a first preselected area 86 of a mold cavity and a negative charge in a 30 second preselected area 87 spaced from the first. Depositing a preselected quantity of the second polymerizable mixture at one of the areas enables an electrical field to draw a portion of the mixture from one area to the other and thereby form a support member 88 therebetween 89. Creating the electrical field along 35 a series of lines along different planes facilitates the construction of a support framework. Similar results can be achieved by incorporating a magnetic material or an electrical charge accepting material in the second polymerizable mixture.

40 When the molded structure within the mold cavity 36 is sufficiently cured that it possesses structural integrity,

rotation is stopped and the mold sections 34 and 35 are separated to free the unit. The molded structure then may be set aside to complete the curing of the resin therein. During this period, the molded structure, free of the mold's restraint, stresses the high density outer skin or layer. This stressing of the skin increases the strength and puncture resistance thereof and also the structural strength of the unit itself.

Another method of the invention as shown in Figure 11 involves the formation of a continuous elastic or resilient first resin layer 90 and thereafter separating mold sections 91. The pressure inside the first resin envelope is changed to sequentially expand or contract the configuration thereof during the formation of a plurality of support members 92 of varying preselected length.

Figure 12 schematically illustrates an example of an overstuffed chair 94 with a first resin outer layer 95 filled with a foam 96 and including a framework 97 of support members. Some support members 98 are full length and resilient to provide a springy effect while others 99 are of a shorter length and more rigid that serve as stops to prevent over depression.

The polymerizable mixtures employed to produce structures of the invention are selected to be capable of reaction to form the particular resin desired in the final structure. Advantageously, the resin is a thermosetting resin such as a polyurethane or polyester. Should a polyurethane be desired, one reservoir 70,71,72 may contain an isocyanate and another reservoir may contain a polyol. More commonly, the reservoirs may contain different partially formed materials which upon mixing interact to form the desired polyurethane. Examples of such partially formed materials include so-called "A stage" resins and "B stage" resins.

Other resin forming systems may utilize a resin forming material in one reservoir and a catalyst in a second reservoir. Additional components can be pre-mixed with one of the resin formers, e.g. fillers, reinforcements, colors and the like. The use of rapid gelling resin formers enables continuous custom support member frameworks to be formed in situ during molding.

The particulate solid additive material may be any of a wide variety of inexpensive materials readily available at a

particular job site. Natural mineral particulate material such as sand and gravel normally are available or can be produced simply by crushing rock at the site.

Also, materials such as waste or recycled materials which can be shredded or ground into particles of suitable size can be utilized. Particularly useful are particles formed by shredding or grinding discarded tires. Since the particles are encapsulated with the resin forming material and not saturated therewith, many different waste materials may be employed.

The above description and the accompanying drawings show that the present invention provides a novel multiaxis rotational molding method and apparatus which not only overcome the deficiencies and shortcomings of earlier expedients, but in addition provide novel features and advantages not found previously. The method and apparatus of the invention provide simple inexpensive means for producing uniform high quality products efficiently.

The apparatus of the invention is simple in design and relatively inexpensive. Commercially available materials and components can be utilized in the fabrication of the apparatus using conventional metal working techniques and procedures.

Structures can be produced automatically with the apparatus of the invention by operators with limited experience and aptitude after a short period of instruction. The apparatus is durable in construction and has a long useful life with a minimum of maintenance.

The method and apparatus of the invention can be utilized to mold a wide variety of different products. Variations in structure, configuration and composition of the products can be achieved simply and quickly with the method and apparatus of the invention.

It will be apparent that various modifications can be made in the multiaxis rotational molding method and apparatus described in detail above and shown in the drawings within the scope of the present invention. The size, configuration and arrangement of components can be changed to meet specific requirements. For example, more than two mold assemblies may be utilized, and they may be arranged in different orientations with respect to one another. In addition, the number and

sequence of processing steps may be different. Also, the apparatus may include other drive and actuating components and mechanisms.

5 These and other changes can be made in the method and apparatus described provided the functioning and operation thereof are not adversely affected. Therefore, the scope of the present invention is to be limited only by the following claims.

10

15

20

25

30

35

40

CLAIMS

1. A method of continuously forming an integrally molded structure in a multiaxis rotational molding operation including the steps of rotating a multisection mold assembly about at least three axes, flowing a first freshly formed polymerizable mixture over surfaces of an enclosed mold cavity within said multisection mold assembly, monitoring said flowing of said first mixture over said mold cavity surfaces and formation of a first resin therefrom, flowing a freshly formed rapidly gelling second polymerizable mixture into said mold cavity, depositing a preselected quantity of said second mixture into contact with a first preselected area of said first resin, drawing a portion of said deposited second mixture as it is gelling toward a second preselected area remote from said first preselected area at a rate to form therefrom a continuous support member with structural integrity extending between said preselected areas of said first resin, continuing said rotation of said multisection mold assembly throughout said steps of said continuous molding operation while monitoring individually each axis rotation of said multisection mold assembly, and coordinating said monitored flowing of each mixture and said monitored formation of each resin with each monitored axis rotation in a preselected profile to form said integrally molded structure of said first and second resins, separating said mold sections of said multisection mold assembly, removing said integrally molded structure from said separated mold sections and repeating said steps to form a multiplicity of said integrally molded structures of said first and second resins on a continuing basis.

2. A method of continuously forming an integrally molded structure in a multiaxis rotational molding operation according to Claim 1 including repeating the steps of depositing a preselected quantity of said second mixture into contact with a different preselected area of said first resin and drawing a portion of said deposited second mixture toward another preselected area remote from said first preselected area to form a plurality of continuous support members with structural integrity extending between different preselected areas of said first resin.

40

3. A method of continuously forming an integrally molded structure in a multiaxis rotational molding operation according to Claim 1 including flowing a third freshly formed polymerizable mixture over said support member and said first resin formed within said mold cavity, monitoring said flowing of said third mixture and formation of a third resin therefrom.

4. A method of continuously forming an integrally molded structure in a multiaxis rotational molding operation according to Claim 1 including creating an electrical field along a line bisecting said mold cavity.

5. A method of continuously forming an integrally molded structure in a multiaxis rotational molding operation according to Claim 1 including successively creating an electrical field along a series of lines bisecting said mold cavity along differing planes.

6. A method of continuously forming an integrally molded structure in a multiaxis rotational molding operation according to Claim 1 including flowing said second polymerizable mixture into said mold cavity through an orifice movable along a preselected path within said cavity.

7. A method of continuously forming an integrally molded structure in a multiaxis rotational molding operation according to Claim 4 including incorporating a magnetic material into said second polymerizable mixture.

8. A method of continuously forming an integrally molded structure in a multiaxis rotational molding operation according to Claim 4 including incorporating an electrical charge accepting material into said second polymerizable mixture.

9. A method of continuously forming an integrally molded structure in a multiaxis rotational molding operation according to Claim 1 wherein said mold sections of said multisection mold assembly are separated before said second mixture is flowed into said mold cavity.

10. A method of continuously forming an integrally molded structure in a multiaxis rotational molding operation according to Claim 9 including the step of changing the pressure within a continuous first resin to distort the configuration during the formation of a support member of preselected length.

11. A method of continuously forming an integrally molded structure in a multiaxis rotational molding operation according to Claim 1 including the step of preconditioning raw materials
5 prior to forming said first, second and third polymerizable mixtures therewith.

12. A method of continuously forming an integrally molded structure in a multiaxis rotational molding operation according to Claim 1 including the step of incorporating a major
10 proportion of solid additive particles in at least one of said polymerizable mixtures.

13. A method of continuously forming an integrally molded structure in a multiaxis rotational molding operation according to Claim 1 including the step of entraining air within at least
15 one of said polymerizable mixtures.

20

25

30

35

40

2187327

PCT/US 95/06301
08 Rec'd PCT/PTO 27 OCT 1995

14. Multiaxis rotational molding apparatus including a support portion, a molding portion, a mixing portion and a control portion; said support portion including an arm member disposed in a generally horizontal orientation and having one end extending from an upstanding supporting section, a transverse supporting member extending from adjacent an opposite end of said arm member; said molding portion including a plurality of mold supporting assemblies rotatably disposed along the length of said transverse supporting member, each of said mold supporting assemblies including an independently rotatable mold connector section, each of said mold supporting assemblies including a central passage therethrough from a rotatable connection with said transverse supporting member and through said mold connector section, a plurality of mold assemblies each including at least two separable mold sections forming a substantially enclosed cavity, connecting means selectively securing said mold sections together and to said mold connector section, said mold sections of said mold assemblies including electrical field generating means; said mixing portion including an elongated mixing section extending axially within said central passage through each of said mold supporting assemblies adjacent said mold connector section, a mixing section including a plurality of deflector sections disposed along the length thereof, a plurality of inlet conduits extending along said arm and transverse supporting members and operatively connected to an inlet end of each of said mixing sections, a hollow probe member extending from an outlet end of each mixing section into said cavity of said adjacent mold assembly; said control portion including actuating means rotating each mold connector section and said mold assembly affixed thereto and actuating means rotating each mold supporting assembly and said mold assembly affixed thereto with respect to said transverse supporting member, programmable memory means storing preselected operating parameters, monitoring means sensing operating information from control components, circuitry transmitting signals from said monitoring means to coordinating means comparing said operating information with said operating parameters stored in said memory means and activating said actuating means to control formation of a molded structure in each of said cavities in a preselected multiaxis mold rotational profile.

2187327

PCT/NO 95/06301
03 Rec'd PCT/PTO 27 OCT 1995

15. Multiaxis rotational molding apparatus according to Claim 14 wherein said electrical field generating means is capable of creating an electrical field along a series of lines bisecting said mold cavity.

5 16. Multiaxis rotational molding apparatus according to Claim 14 wherein said arm member includes at least one pivotal connection along a length thereof.

10 17. Multiaxis rotational molding apparatus according to Claim 14 including actuating means axially moving said probe member within said mold cavity.

18. Multiaxis rotational molding apparatus according to Claim 14 wherein said actuating means includes a variable speed gear motor, a chain and sprockets.

15 19. Multiaxis rotational molding apparatus according to Claim 14 wherein each of said mold assemblies includes a vent disposed concentrically with said probe member.

20 20. Multiaxis rotational molding apparatus according to Claim 14 wherein said monitoring means includes optical fibers extending through said mold sections.

20

5

10

15

20

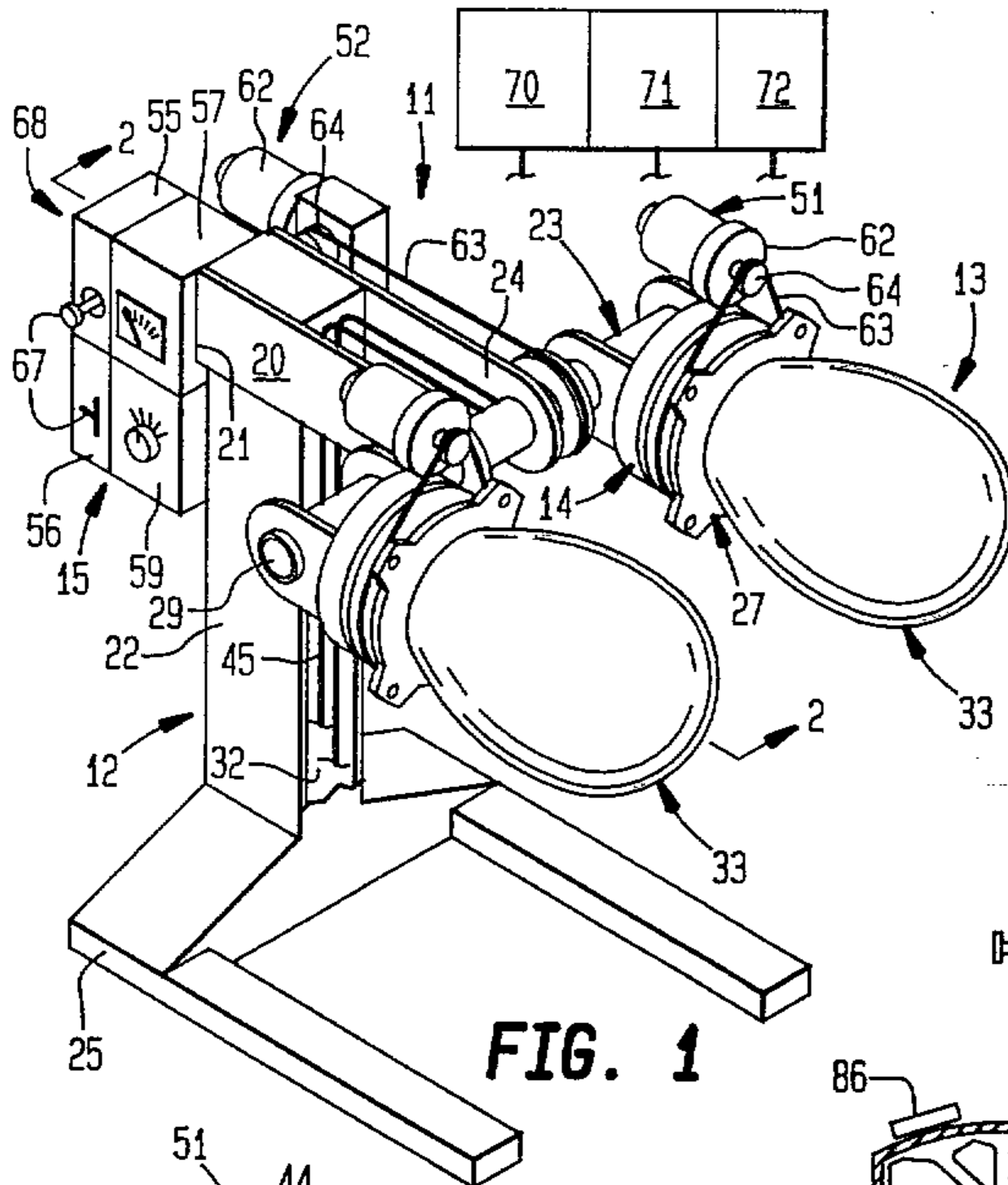

FIG. 1

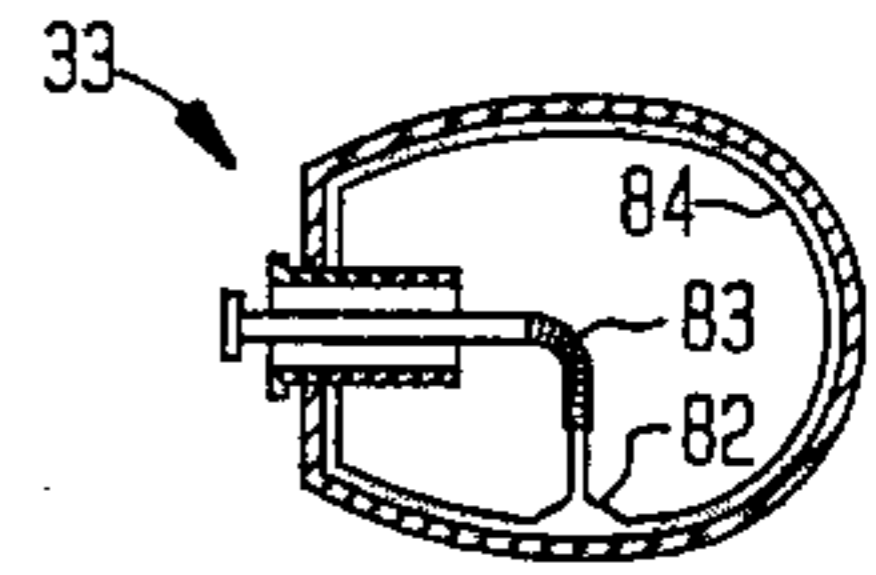

FIG. 7

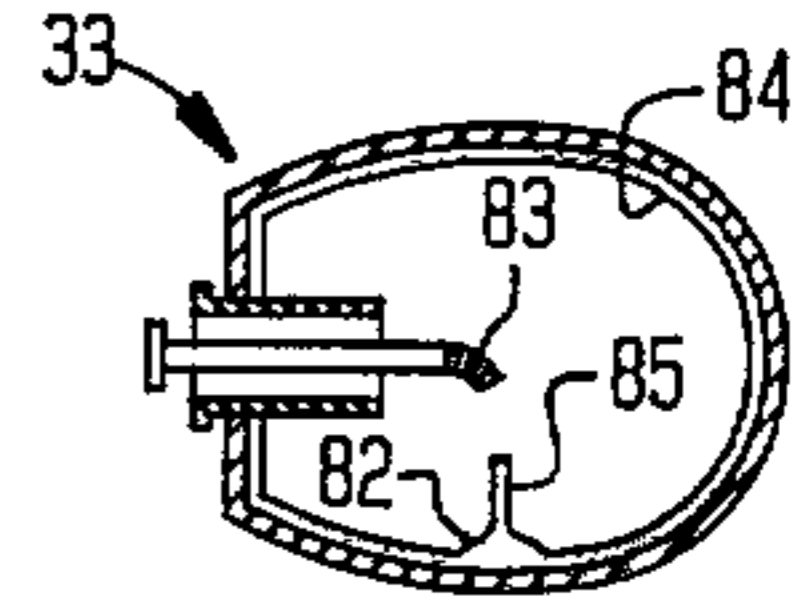

FIG. 8

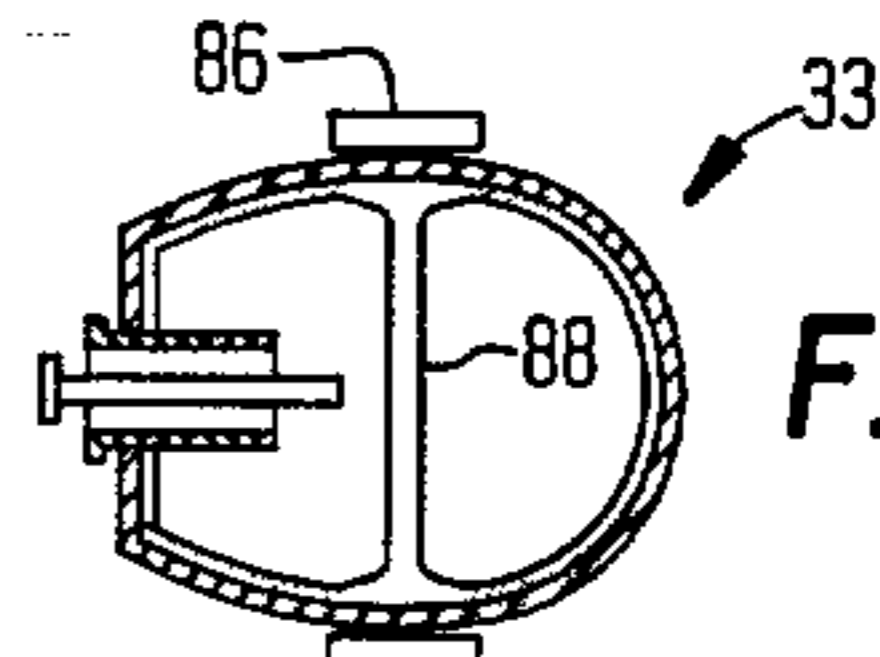

FIG. 9

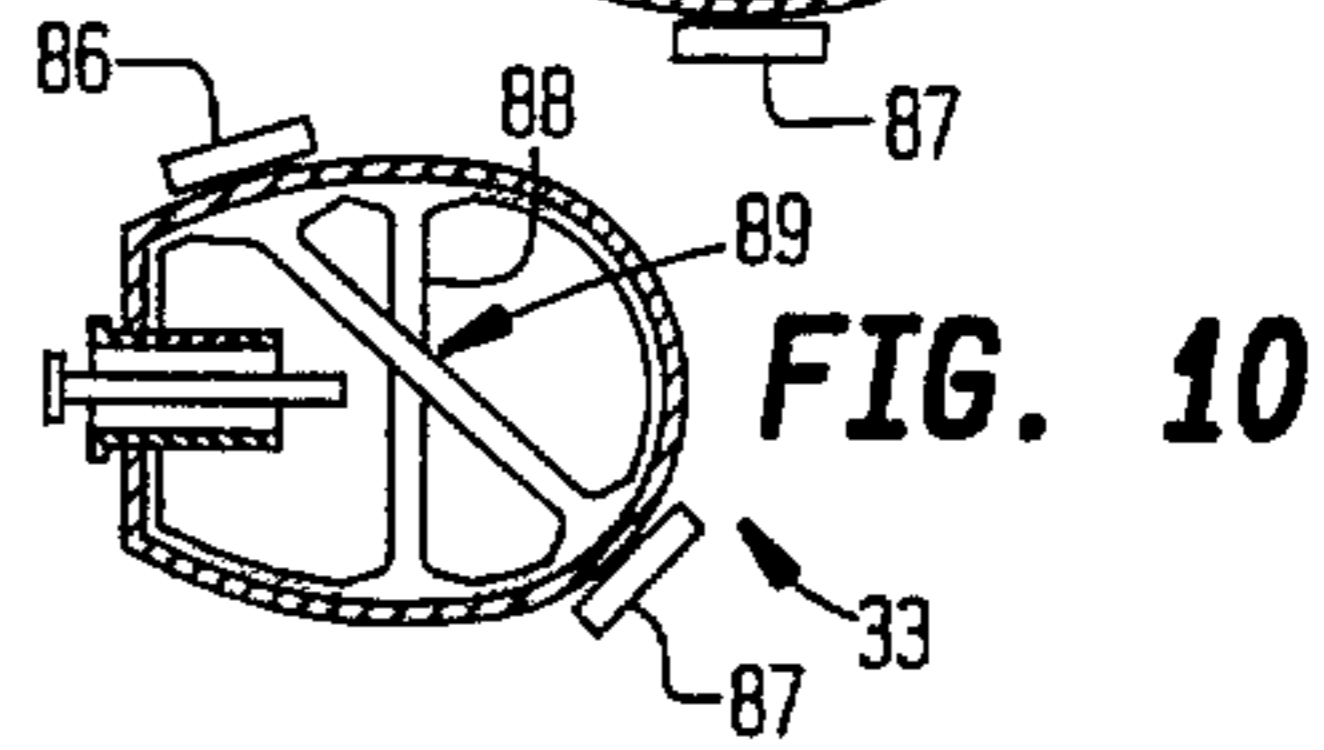

FIG. 10

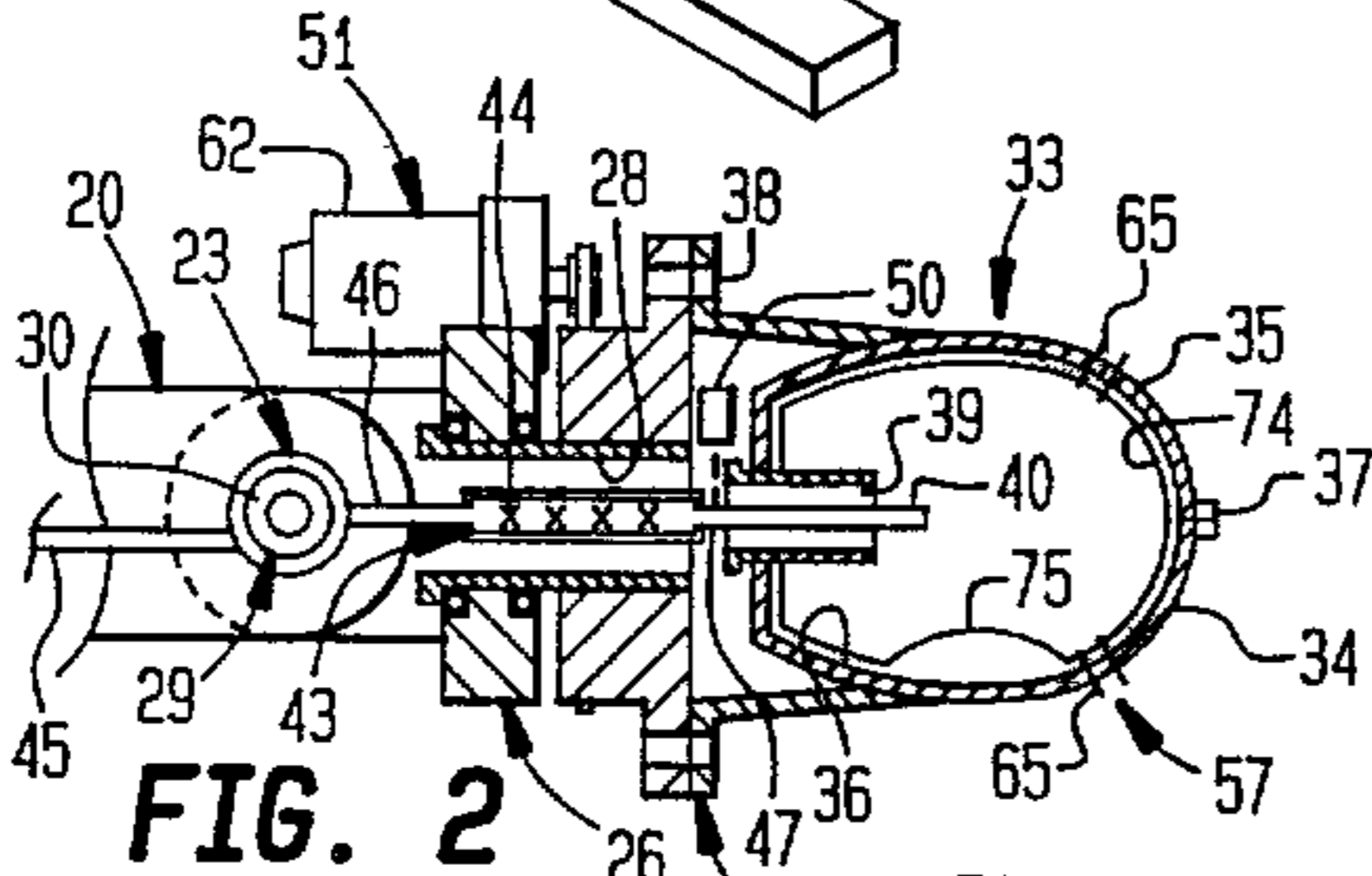

FIG. 2

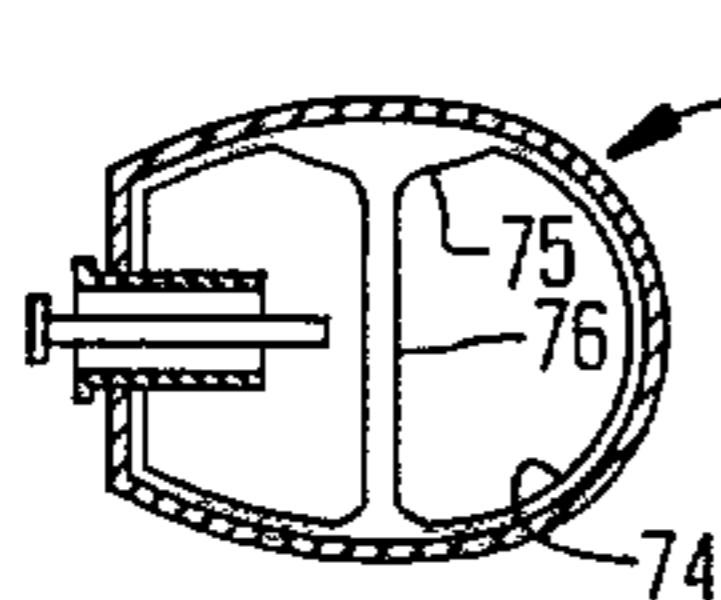

FIG. 3

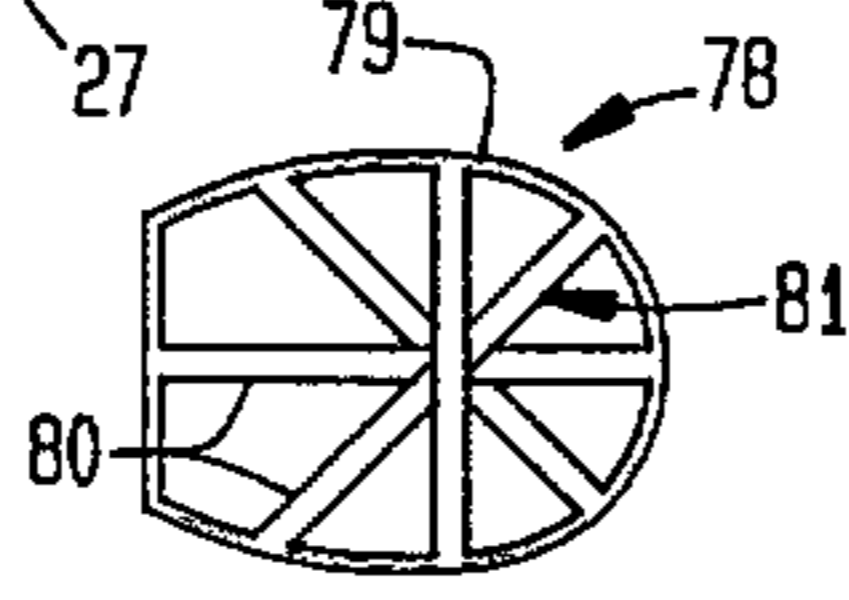

FIG. 6

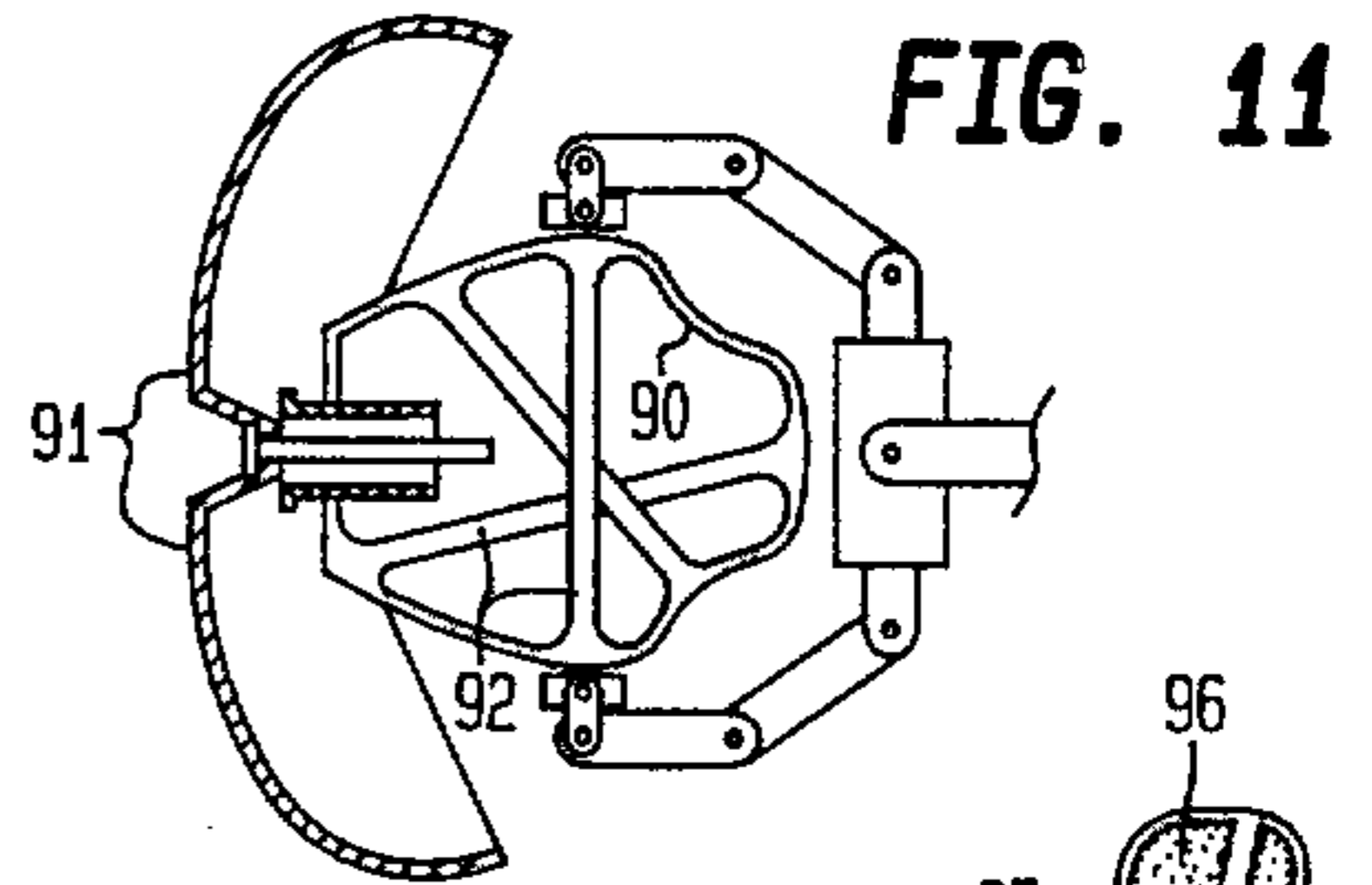

FIG. 11

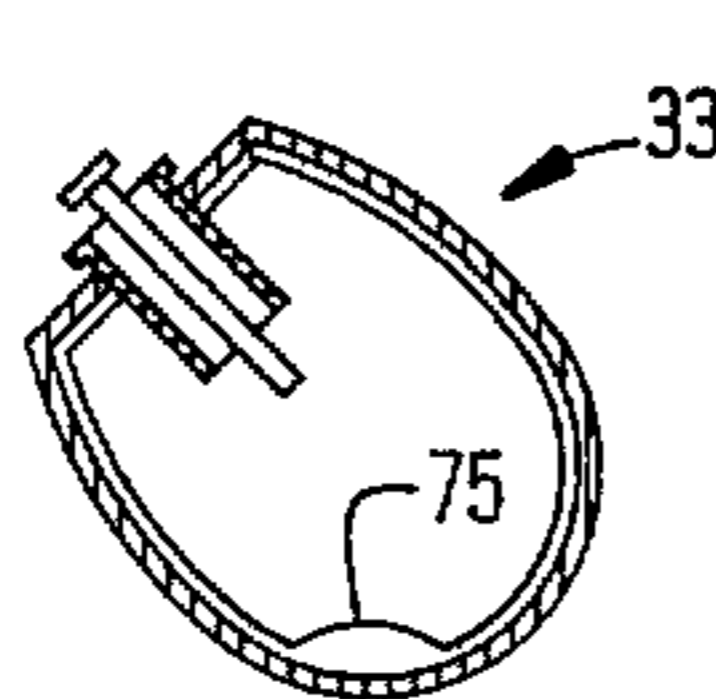

FIG. 4

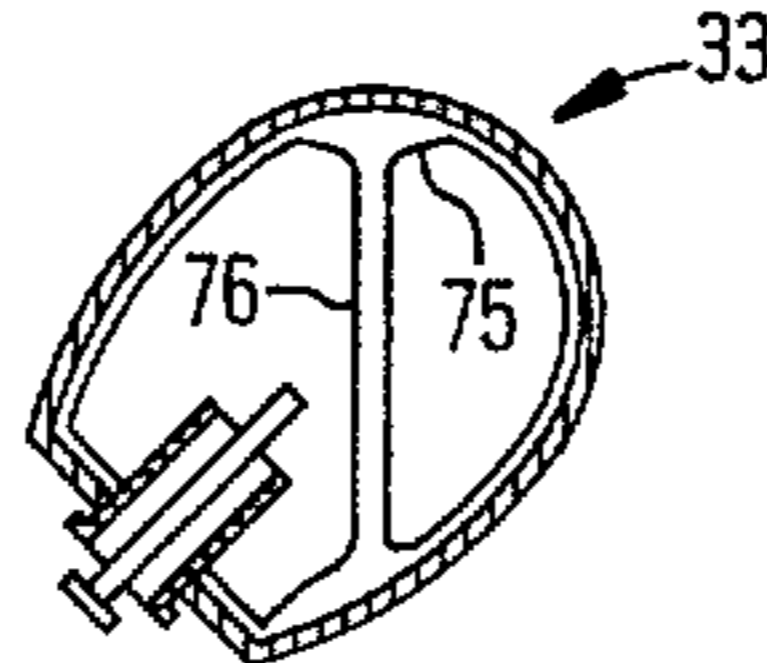

FIG. 5

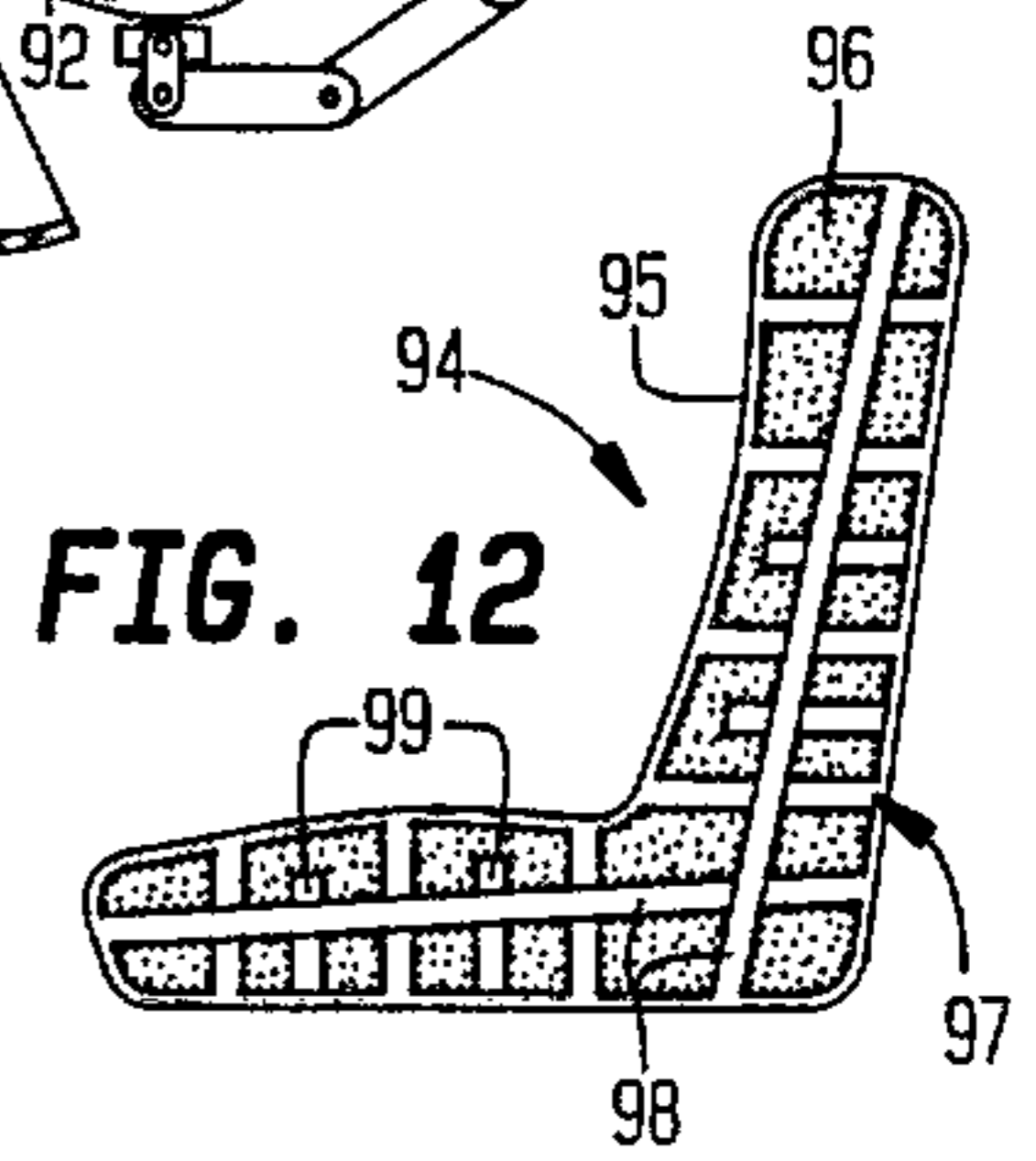

FIG. 12

