

Dec. 16, 1924.

1,519,829

G. H. GILMAN

PNEUMATICALLY FED TOOL

Filed Nov. 8, 1918

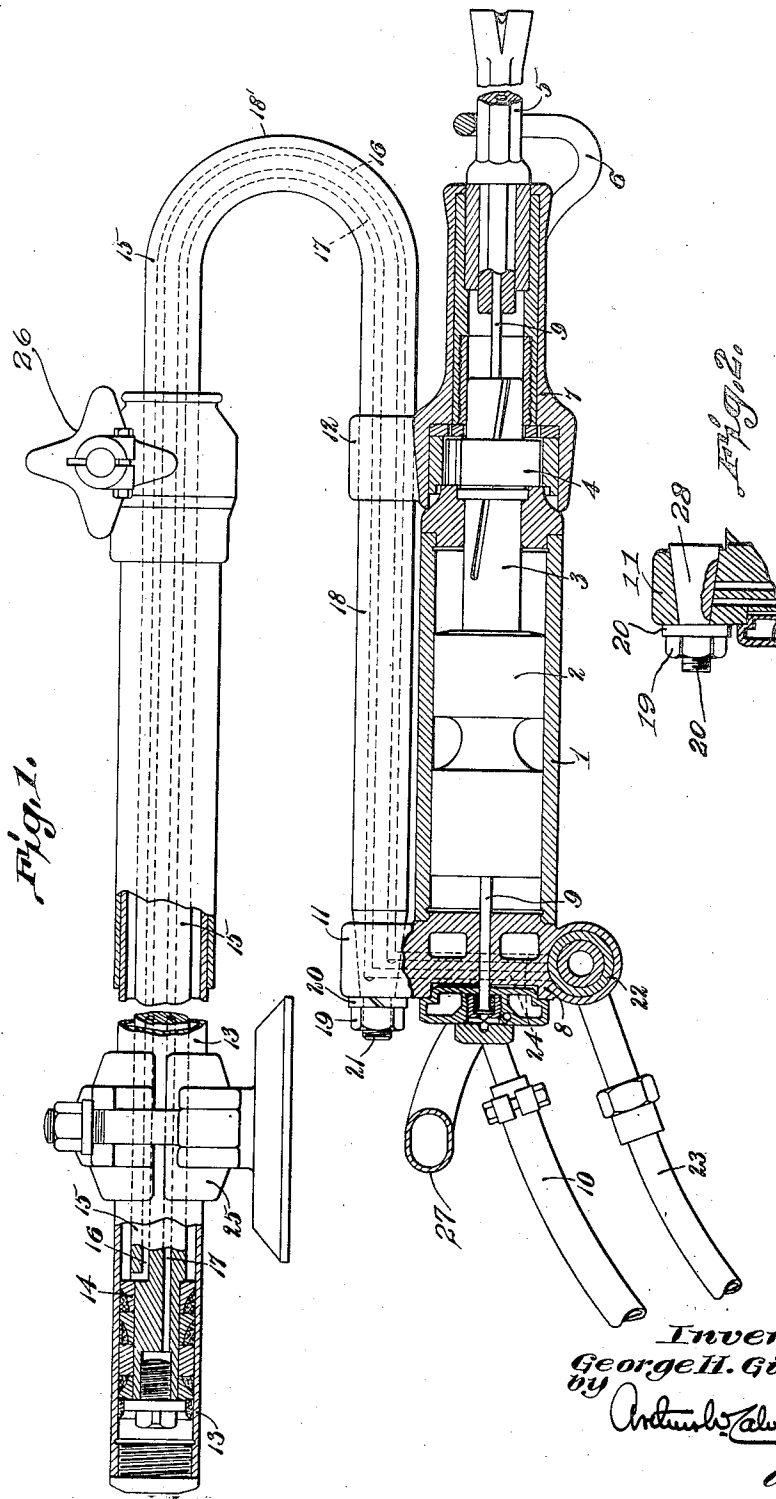

UNITED STATES PATENT OFFICE.

GEORGE H. GILMAN, OF CLAREMONT, NEW HAMPSHIRE, ASSIGNOR TO SULLIVAN MACHINERY COMPANY, A CORPORATION OF MASSACHUSETTS.

PNEUMATICALLY-FED TOOL.

Application filed November 8, 1918. Serial No. 261,686.

To all whom it may concern:

Be it known that I, GEORGE H. GILMAN, a citizen of the United States, residing at Claremont, in the county of Sullivan and State of New Hampshire, have invented certain new and useful Improvements in Pneumatically-Fed Tools, of which the following is a full, clear, and exact specification.

This invention relates to pneumatically fed tools, and more particularly to pneumatically fed drills of the type used in mining or quarrying, the principal object of the present invention being to provide a means for supporting the drilling mechanism on the feeding mechanism in such a manner that the apparatus may be used in a limited space, and that the drilling mechanism is not liable to change its position angularly relative to the feeding mechanism, but will remain parallel thereto.

In order to obtain a simple and easily controlled apparatus it has been the practice, heretofore, to mount the drilling machine on the front end of or ahead of the feeding mechanism and to provide a single member for connecting the machine and mechanism. This construction is not adapted for use in narrow passages or rooms because of its great length, and, because of the single connection commonly used between the drill and the feeding mechanism, it is difficult to align the two accurately so that the drill will operate parallel to the feed. By my improved construction, the simplicity of the apparatus has been maintained, and the supporting means has been improved in such a manner that a more rigid, compact, and easily aligned apparatus is obtained. These and other objects and advantages of my improvement will, however, hereinafter more fully appear.

In the accompanying drawings I have shown for purposes of illustration one embodiment which my invention may assume in practice.

In these drawings,

Fig. 1 is a side elevation of a pneumatically fed drilling machine, parts of the feeding and drilling mechanisms being shown in section.

Fig. 2 is a fragmentary sectional view through the rear end of the drill mounting means, showing the drill ready for use as a hand tool.

In this illustrative embodiment I have

shown a pneumatic hammer drill comprising a cylinder or casing 1, a hammer piston 2 reciprocatively mounted therein and carrying on one end a rifled striking head 3, which actuates a ratchet drill rotating mechanism 4, and transmits the energy of the piston to a drill steel 5. A drill steel retainer 6 is used to keep the drill shank in the sleeve of the rotating mechanism and to assist in removing stuck drills. A large, somewhat tapered sleeve 7 encloses the rotating mechanism and is rigidly held against the front cylinder head by suitable clamping means (not necessary to show herein).

Mounted in a back cylinder head 8 is a small water tube 9 which projects centrally through the piston and rotating mechanism into the hollow drill steel, and cooperates with suitable passages in the cylinder head, and with a pipe 10, to conduct water to the drill steel, as is common in drilling machines of this type. A valve (not shown) is usually mounted on the water conductor 10 to control the flow of water to the cutting end of the steel to remove cuttings or chips.

In the form of my improvement shown herein, I have provided the pneumatic hammer with two spaced supporting members or brackets 11, 12 mounted respectively on the head 8 and sleeve 7, the brackets in this embodiment being widely spaced so as better to provide against a turning movement of the hammer on its support. Obviously, through the construction just described it is necessary to move one or both of the brackets in order to disassemble the cylinder or rotating mechanism. This is not a disadvantage, but rather quite an advantage, for to remove the cylinder, piston or rotating mechanism it is only necessary to slide the sleeve 7 forward on the supporting arm until the cylinder or ratchet mechanism drops out, the remaining parts being supported by the arm. However, one or both of the brackets may be mounted on the cylinder in such a manner that the head 8 or the sleeve 7 and the operating parts of the pneumatic hammer may be easily removed. Such changes will be obvious to those skilled in the art, and it is the intention to include all such modifications within the scope of the present invention.

The pneumatic feeding device comprises a cylinder 13, a piston 14, and a piston rod 15 having two longitudinally disposed pas-

sages 16, 17 which communicate respectively with the front and back of the piston 14 for the purpose of conducting pressure fluid to one or both ends of this piston or to exhaust the fluid therefrom to move the piston, which in turn moves the pneumatic hammer. For this latter purpose, I have provided the piston rod with a reversed end 18, disposed parallel to and preferably beneath the main part of the piston rod 15. If desired, this rod may be made in sections which may be bolted or threaded together, but in the present embodiment the piston rod 15 and the supporting member 18 are preferably made of a single piece in order to simplify and strengthen the construction.

The outer reversed end 18 of the piston rod 14 I preferably term the hammer support, since it is made to pass through the brackets 11, 12 and is held in fixed relation thereto by a nut 19 and a split ring washer 20. As is shown by the dotted lines, the end of the hammer support has a tapered fit in the bracket 11, it being apparent that by turning the nut 19 on the threaded bolt 21 formed on the end of the support, the hammer is rigidly secured to said support. Attention is here directed to the fact that the bend 18' in the piston rod which connects the portions 15 and 18, and the length of the hammer support 18 may be so proportioned to the length of the hammer that the forward end of the hammer will not project beyond the bend 18' in the piston rod and that the bent end and hammer will project a minimum distance beyond the end of the cylinder 13. By this improved construction the overall length of the apparatus is but slightly greater than the length of the cylinder 13 and for use in restricted mine passages the overall length of the apparatus may be materially reduced by using a shorter cylinder. It will also be noted that the front end of the hammer is back of the bend in the piston rod, so that when the drill is fed forward the bent rod will strike a mine wall first and keep the hammer from contacting with the wall in case a steel retainer is not used, and even if the latter is used, owing to its construction, but little shock will be imparted to the drill.

Cooperating with my improved mechanism just described, I have provided a conical valve 22, herein shown as mounted in the cylinder head 8, which directs the flow of fluid pressure supplied to the end of this valve by a hose 23, to the ends of the cylinder 13 to operate the pneumatic feed and to the cylinder 1 to operate the pneumatic hammer. Since the valve structure forms no part of the present invention, and since one form which this valve may assume is fully disclosed in my Patent No. 1,250,933, issued December 18, 1917, the same has not been disclosed in detail, it being thought

sufficient for the present disclosure to show the ducts 24 bored in the cylinder head 8 and communicating with the valve 22 and ducts or passages 16, 17 to conduct the fluid flow from the valve to either end of the piston 14.

At the forward end of my feed cylinder, it will be noted that I have provided a brake mechanism 26 the details of whose construction are not illustrated in view of the fact that they are well known and correspond generally to the disclosure of the patent granted me, No. 1,151,261. The rate of feed of the tool can in a well known manner be controlled by this brake.

In order that this apparatus may be attached to a support, as a bar or tripod, and in order that the pneumatic cylinder may be advanced toward the work as the hole is deepened, a clamping device 25 is provided which may be clamped to the cylinder 13 at any point throughout its length.

It will be obvious that I can swing my drill to any relative angular position about the axis of the feed cylinder as a pivot, thereby rendering the changing of steels very much easier and also permitting the drilling of a number of holes about a circumference without changing the position of the drill mounting as a whole. It will further be noticed that by merely removing the bolt 19 and the split ring 20, it is possible to remove the motor by sliding it rearwardly off of the rod 18 and that a motor of different length can be attached thereto in place of the motor removed, as there is ample room on the lower arm of the piston rod U to make this possible. I have shown, as will be noted, my tool provided with a handle 27 which makes it possible to employ the tool as a separate hand tool by plugging off the bores 24 by means of a suitable conical plug which may be inserted in the socket in the rear head on removal of the motor from its mounting. This construction is shown in Fig. 2.

While I have herein shown and described for the purpose of illustration, one specific form of the invention, it is to be understood that the same has been chosen for illustrative purposes only and that extensive deviations may be made from the disclosed form thereof without departing from the spirit of the invention.

What I claim as new and desire to secure by Letters Patent is:

1. In a drilling apparatus, a tool, a mounting therefor comprising a feed cylinder, a piston rod of substantially U-shape with a piston secured to one arm of said U and reciprocable in the feed cylinder, and means for attaching said tool to the other arm of said U, said piston rod constituting the sole means by which said tool is supported relative to said feed cylinder.

2. In a drilling apparatus, a motor, a feed cylinder cooperating therewith, a piston in said feed cylinder, a piston rod secured to said piston and having a re-bent arm, and means formed at the rear end of said re-bent portion for attachment to said motor, said piston rod constituting the sole means by which said tool is supported relative to said feed cylinder.
3. In a drilling apparatus, a motor, a feed cylinder cooperating therewith, a piston in said feed cylinder, a piston rod secured to said piston and having a re-bent arm, means formed at the rear end of said re-bent portion for attachment to said motor, and clamping means provided on said motor to cooperate with said re-bent portion at a spacially separated point, said piston rod constituting the sole means by which said tool is supported relative to said feed cylinder.
4. In a drilling apparatus, the combination including a motor, a feeding mechanism for said motor comprising a cylinder, a piston reciprocable in said cylinder, a U-shaped piston rod, and means formed on said motor for connecting the same at a plurality of points to the free arm of said U, said piston rod constituting the sole means by which said tool is supported relative to said feed cylinder.
5. In a drilling apparatus, the combination including a tool, a feeding device for said tool including a feed cylinder, a piston reciprocating therein and a U-shaped piston rod, one arm of which is secured to said piston and to the other arm of which said tool is attached, said tool being capable of being swung about the longitudinal axis of said first mentioned arm.
6. In a drilling apparatus, a tool comprising a cylinder member, front and back head members, and a rotation mechanism containing sleeve member, in combination with a feeding device cooperating therewith and having a piston rod connected to the rear head member and to the sleeve member of the motor.
7. In a drilling apparatus, the combination including a tool, a feeding mechanism for said tool including a feed cylinder, a piston reciprocating therein, and a U-shaped piston rod cooperating with said piston, the free arm of which may be swung about the longitudinal axis of the other arm, and means for mounting said tool on said free arm whereby the forward end of said tool is substantially opposite the bend of said U.
8. In a drilling apparatus, the combination including a tool, a device for moving the tool including a feed cylinder and piston, and a U-shaped piston rod cooperating therewith, one end of which is secured to said position and the other end of which provides means of connection for said tool at a plurality of points, one of said connections being a slidable connection, the other being a rigid connection.
9. In a drilling apparatus, the combination including a motor, and feeding mechanism therefor comprising a cylinder, a piston reciprocating therein, and a piston rod secured to said piston, said piston rod having a re-bent portion parallel to said portion attached to the piston, said re-bent portion having formed thereon means for rigid attachment to the rear end of said motor, and said motor being formed at its front end with means for attachment to said arm.
10. In an apparatus of the class described, the combination including a cylinder, a piston and piston rod associated therewith, a pneumatic hammer, and means connected with said piston rod and projecting rearwardly from the front end of the cylinder for supporting the hammer, said rod and means constituting the sole means by which said tool is supported relative to said feed cylinder.
11. In an apparatus of the class described, the combination including a pneumatic hammer, a sleeve thereon, a support, a bracket rigidly mounted on said hammer and support, and a second bracket rigidly mounted on the sleeve but movably mounted on said support.
12. In an apparatus of the class described, the combination including feeding mechanism comprising a cylinder, a piston and a rod having a supporting end and fluid pressure passages therein, a pneumatic hammer, a plurality of brackets on said supporting end and hammer, passages in one of said brackets communicating with the passages in said rod, and a valve for controlling the flow of pressure fluid through said passages and to said hammer, said hammer being bodily rotatable about the axis of said cylinder.
13. In an apparatus of the class described, the combination including feeding mechanism comprising a cylinder, a piston and a rod having a supporting end and fluid pressure passages therein, a pneumatic hammer, a plurality of brackets on said supporting end and hammer, passages in one of said brackets communicating with the passages in said rod, and a valve mounted on said hammer for controlling the flow of pressure fluid through said passages and to said hammer, said hammer being bodily rotatable about the axis of said cylinder.
- In testimony whereof I affix my signature.

GEORGE H. GILMAN.

Certificate of Correction.

It is hereby certified that in Letters Patent No. 1,519,829, granted December 16, 1924, upon the application of George H. Gilman, of Claremont, New Hampshire, for an improvement in "Pneumatically-Fed Tools," errors appear in the printed specification requiring correction as follows: Page 3, lines 4 and 5, claim 2, for the words "re-bent arm" read *reversed end*; same page, line 6; claim 2, and lines 15, 17, and 18, claim 3, for the words "re-bent portion" read *reversed end*; same page, lines 13 and 14, claim 3, for the words "re-bent arm" read *reversed end*; same page; line 64, claim 8, for the word "position" read *piston*; and that the said Letters Patent should be read with these corrections therein that the same may conform to the record of the case in the Patent Office.

Signed and sealed this 10th day of February, A. D. 1925.

[SEAL.]

KARL FENNING,
Acting Commissioner of Patents.